

6 5 4 3 2 1

D
C
B
A

D
C
B
A

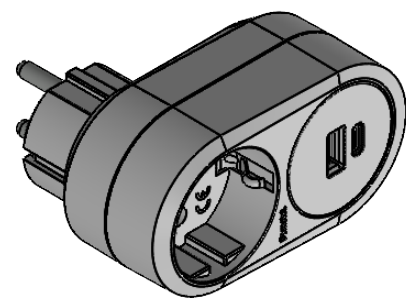
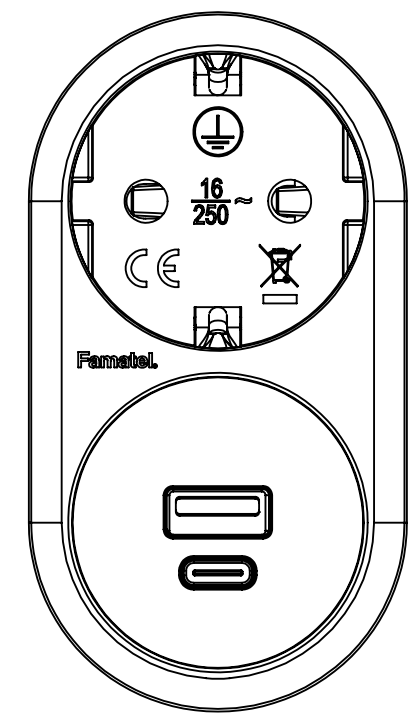
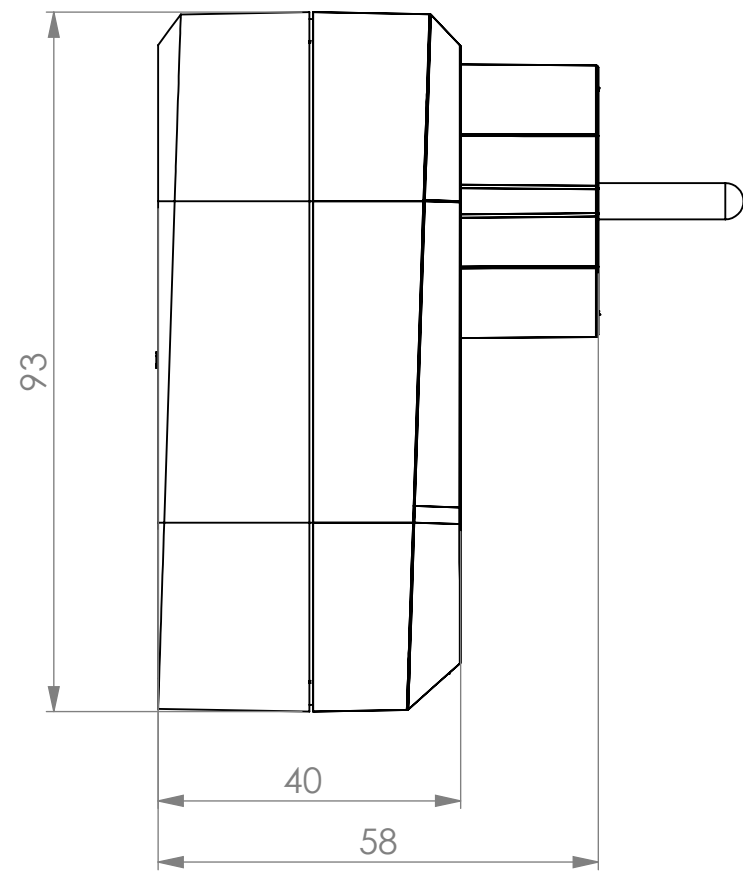
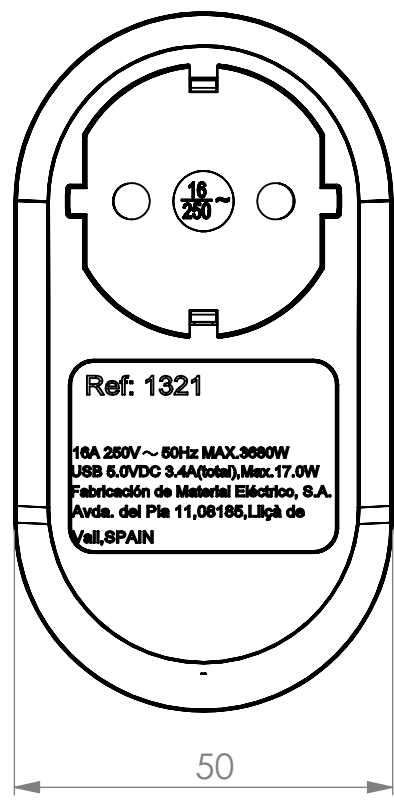

ACABADO DE PIEZA
 -Realizar grabados indicados en el 2D.
 -Cara vista pulido espejo
 -Cara no vista pulido industrial fino
 -Tolerancia para cotas inferiores a 100 ± 0.1
 -Tolerancia para cotas inferiores a 200 ± 0.2
 -Tolerancia para cotas inferiores a 400 ± 0.3
 -Tolerancia para cotas inferiores a 500 ± 0.4
 -Radios no indicados 0.25
 -Desmoldeos no indicados 1*

PIECE OF FINISH
 -Engravings shown in 2D
 -View shows mirror polish
 -Not seen polishing industry fine
 -Tolerance for heights below 100 ± 0.1
 -Tolerance for heights below 200 ± 0.2
 -Tolerance for heights below 400 ± 0.3
 -Tolerance for heights below 500 ± 0.4
 -Rad. Not shown 0.25 mm
 -Draft not shown 1*

ED	Radios sin acotar a 0.3mm. Todas las Tolerancias $\begin{smallmatrix} +0.1 \\ -0.1 \end{smallmatrix}$			VALID	
EDIC	MODIFICATION/MODIFICATION		FECHA/DATE	VALIDADO/VALIDATE	
Descripción/Description:				 Nuestra propiedad exclusiva, está prohibida la modificación, reproducción o difusión a terceros Our exclusive property, modification, reproduction or dissemination to third parties is prohibited	
1321					
Código/Code: xxxxx				Página/Page 1 de/to 1 Escala/Scale 1:1 Tolerancia general General tolerances -	
MATRIZ/MOLDE	N°.M.	N° FIGURAS	N°.F		NORMA PIEZA/STANDARD
DIBUJADO/DRAWING		Fecha/Date:			MATERIAL/MATERIAL
VALIDADO/VALIDATE		R.Rosi/P.Gordillo			TRAT. SUPERFICIAL
ACEPTADO/ACCEPTED		O.Grandi			TRAT. TERMICO

6 5 4 3 2 1