

CE CE
EN14428 EN12150

GME

- ES** Todas las mamparas han sido diseñadas y fabricadas de acuerdo con EN14428
Todos los cristales utilizados en nuestros productos están certificados y probados de acuerdo con EN12150
- EN** All shower products are designed and manufactured according to EN14428
All the glass used on the product are certified and tested according to EN12150
- FR** Toutes les parois ont été conçues et fabriquées conformément à EN14428
Toutes les verres utilisés dans nos produits sont certifiés et testés conformément à EN12150
- IT** Tutti i box doccia sono stati disegnati e fabbricati in accordo con EN14428
Tutti i cristalli utilizzati nei nostri prodotti sono certificati e collaudati in accordo con EN12150

MANUAL INSTRUCCIONES

MODELO TWENTY

FRONTAL 1 FIJO + 1 CORREDERA
1 FIX + 1 SLIDING DOOR

- ES** VIDEO DE INSTALACIÓN
Escanea el código QR para acceder al video de instalación.

- EN** INSTALLATION VIDEO
Scan the QR code to play the installation video.



- ES** MANUAL DE INSTALACIÓN
No tirar. Guardar el manual de instalación para un uso posterior.
- EN** INSTALLATION MANUAL
Do not discard. Save the installation manual for further use.
- FR** MANUEL D'INSTALLATION
Ne pas jeter. Garder le manuel d'installation pour un usage postérieur.
- IT** MANUALE DI INSTALLAZIONE
Non cestinare. Conservare il manuale di installazione per un utilizzo posteriore.

IMPORTANT INFORMATION / INFORMACIÓN IMPORTANTE / INFORMATIONS IMPORTANTES / INFORMAZIONI IMPORTANTI

- EN** • Always wear safety goggles and work gloves when installing or disassembling this product, especially when working with glass panels.
- When handling, never rest the corner of the glass directly on the floor or hit the corner with any object. This can cause the glass to break.
- Always have two persons to install or disassemble the shower.
- Small children should never use the shower unsupervised or without proper instructions for safety use.
- Small children should never hit, lean, or hang on the shower product. Nor should they do any inappropriate activity in the vicinity of the shower.
- Tempered safety glass is designed to shatter into small tiny pieces when the glass is broken, this is to avoid serious injury.
- ES** • Llevar gafas y guantes de seguridad durante la instalación o desmontaje de este producto, especialmente durante la manipulación de los cristales
- Durante la manipulación, nunca dejar descansar las esquinas de los cristales directamente en el suelo o golpearlos con cualquier objeto. Puede provocar la rotura del cristal
- Es conveniente que la instalación o el desmontaje sea llevado a cabo por dos personas.
- Los niños no deben usar la ducha sin supervisión o sin apropiadas instrucciones de uso para sus seguridad
- Los niños no deben, bajo ningún concepto, golpear, apoyarse o colgarse de los productos de ducha. De la misma manera, deberán realizar actividades inapropiadas en las inmediaciones de la mampara.
- El cristal templado de seguridad ha sido diseñado para romper en pequeñas piezas con el objetivo de evitar daños mayores
- FR** • Porter des lunettes et des gants de sécurité aux cours de l'installation de ce produit, en particulier pendant la manipulation des verres.
- Pendant la manipulation ne jamais laisser reposer les coins des verres directement par terre ou les choquer avec n'importe quel objet. Cela peut provoquer la brisure du verre.
- Il est souhaitable que l'installation ou le déballage soit réalisé par deux personnes.
- Les enfants ne doivent pas, en aucun cas, choquer, s'appuyer ou se pendre des produits de douche. De la même manière ils ne devront pas réaliser des activités inappropriées à proximité de la paroi.
- Le verre tempéré de sécurité a été conçu pour casser en petites pièces afin d'éviter de plus grands dommages.
- IT** • Indossare occhiali e guanti protettivi durante l'installazione o smontaggio di questo prodotto, specialmente durante la manipolazione dei cristalli.
- Non appoggiare mai gli angoli dei cristalli direttamente al suolo o colpirli con qualunque oggetto durante la manipolazione. Il cristallo potrebbe rompersi.
- È conveniente che l'installazione o lo smontaggio siano eseguiti da due persone contemporaneamente.
- I bambini non devono usare la doccia senza la supervisione di un adulto o senza le dovute istruzioni di sicurezza
- I bambini non devono colpire, appoggiarsi o appendersi agli elementi della doccia. Non dovranno, inoltre, realizzare attività inappropriate in prossimità del box doccia.
- Il cristallo temperato di sicurezza è stato disegnato affinché si rompa in piccoli pezzi onde evitare danni maggiori.

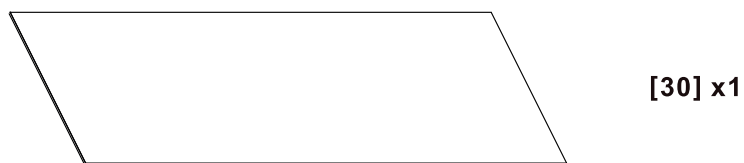
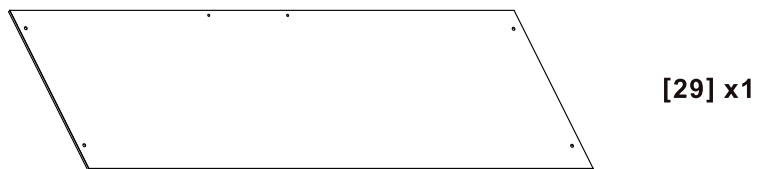
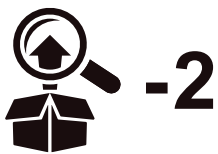
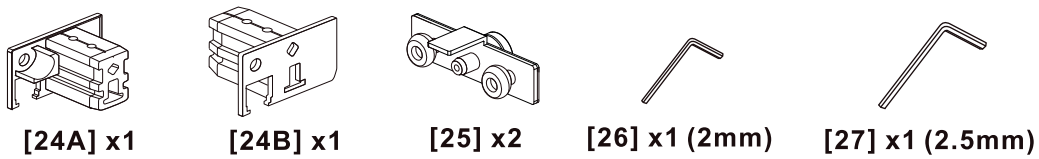
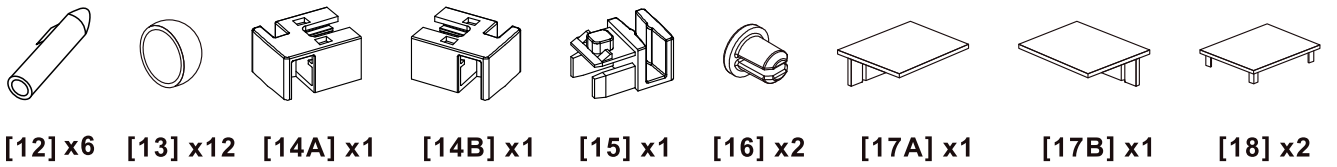
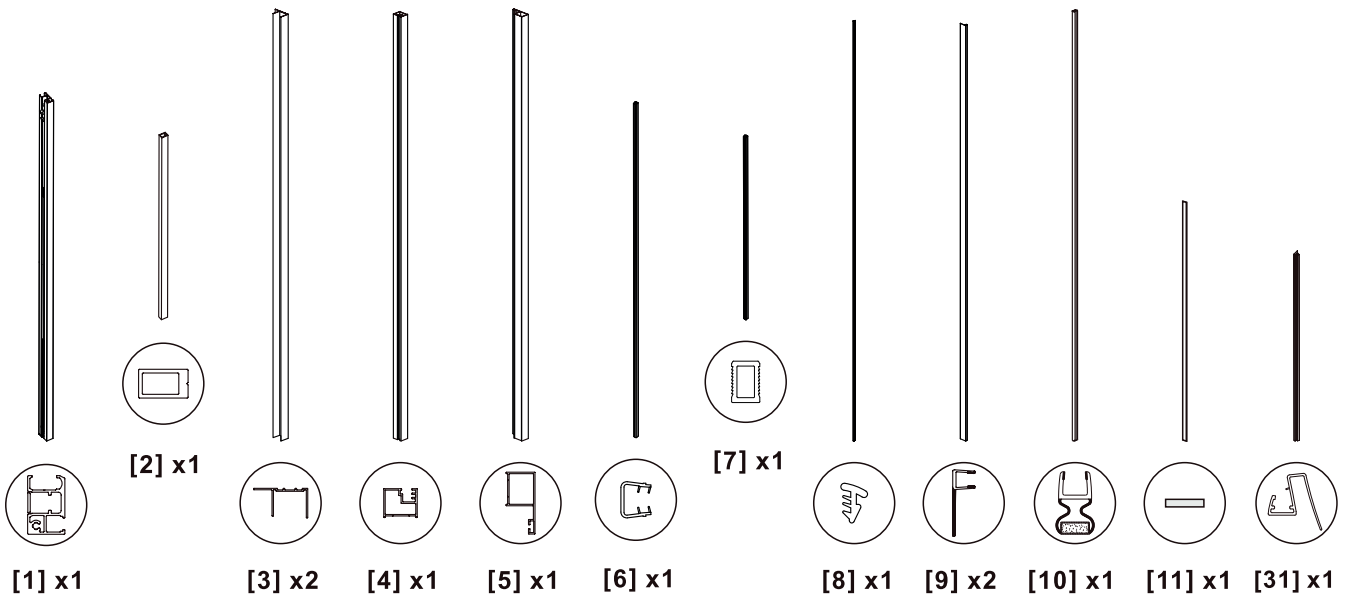
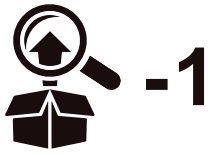



01

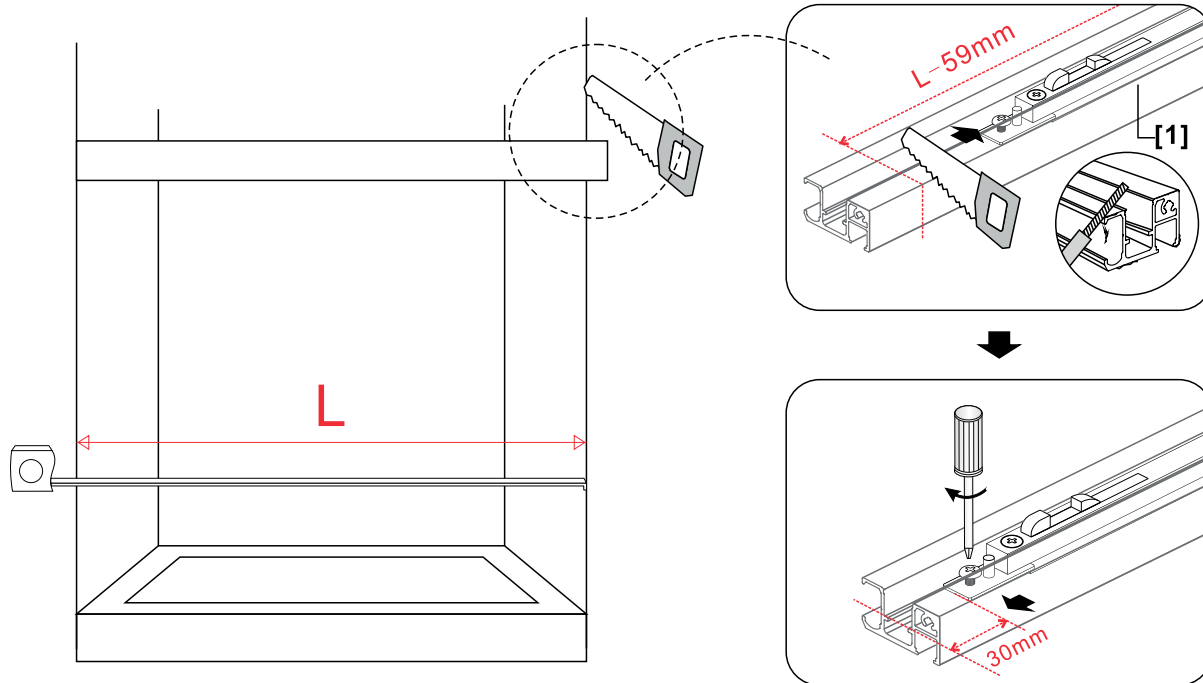

02

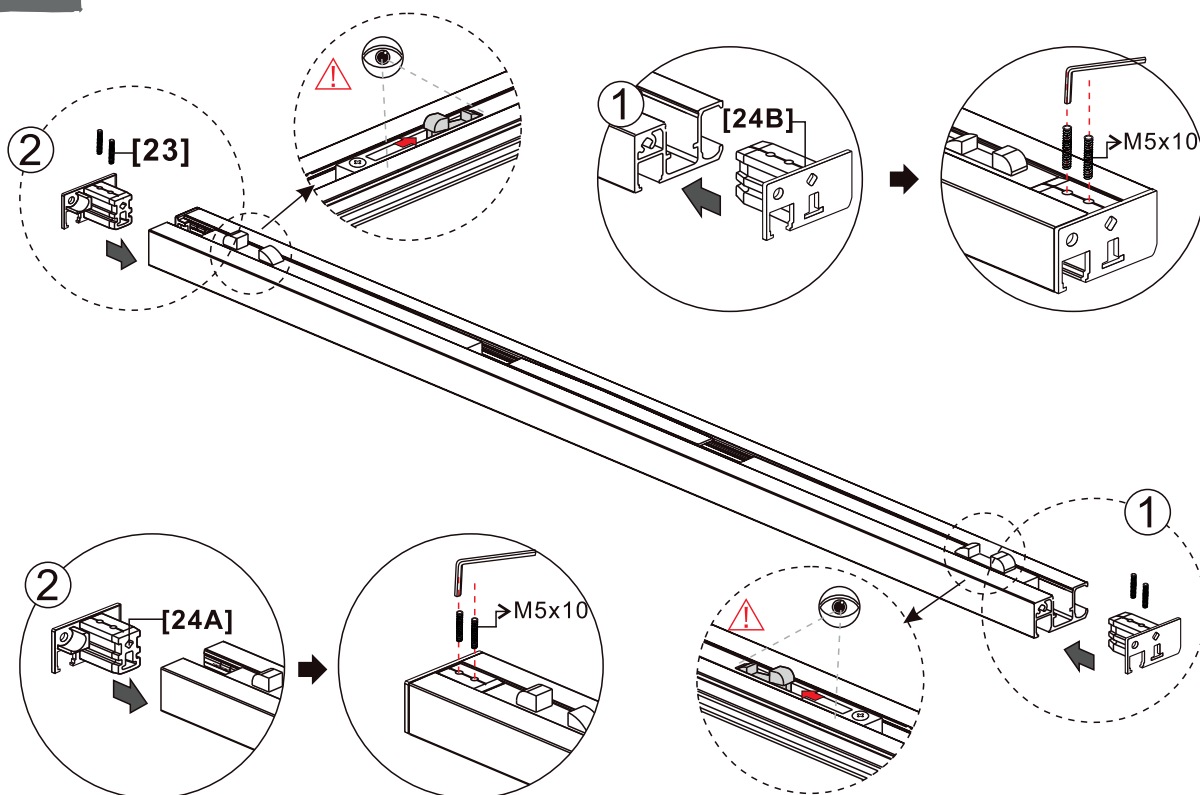

03

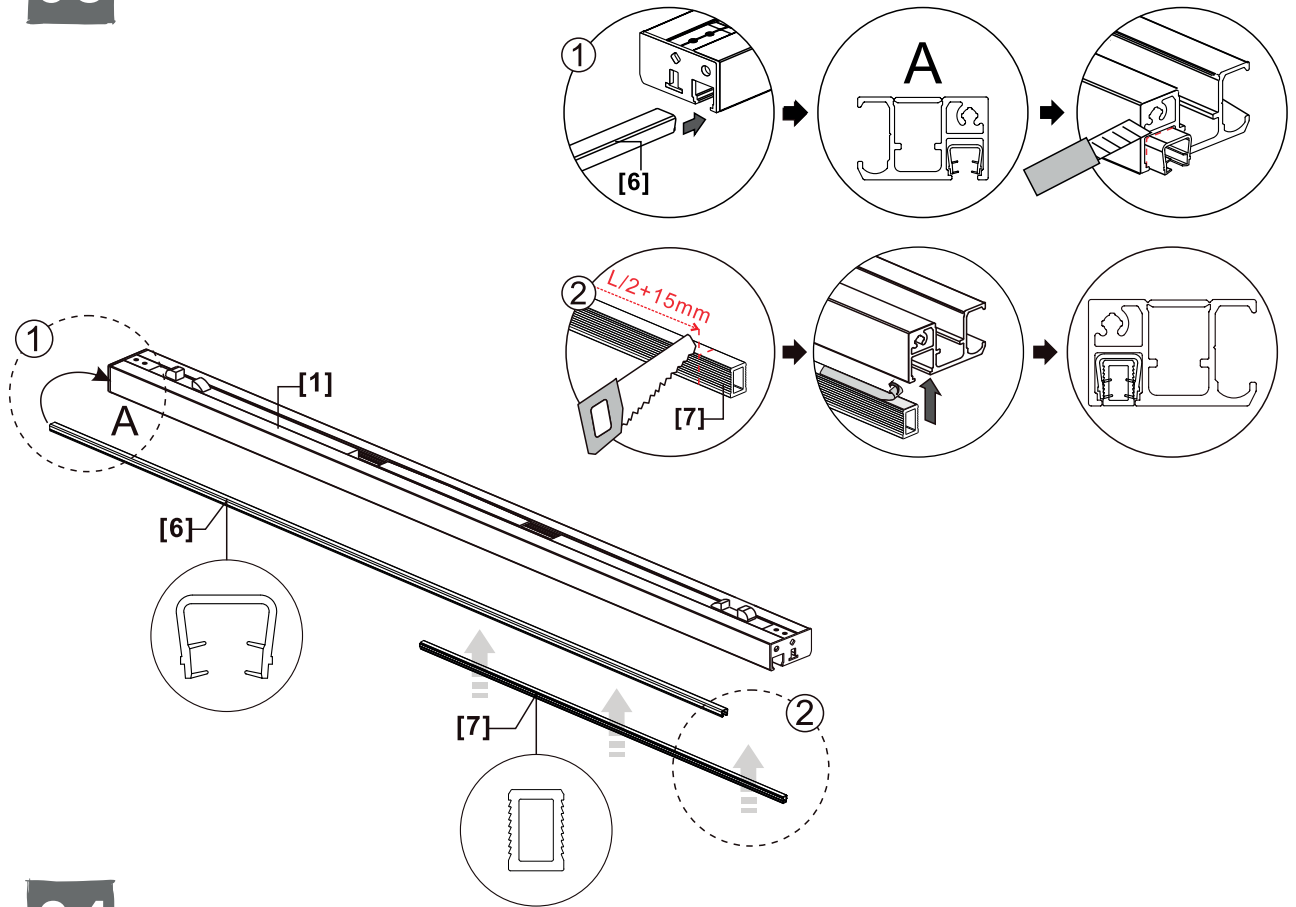

04

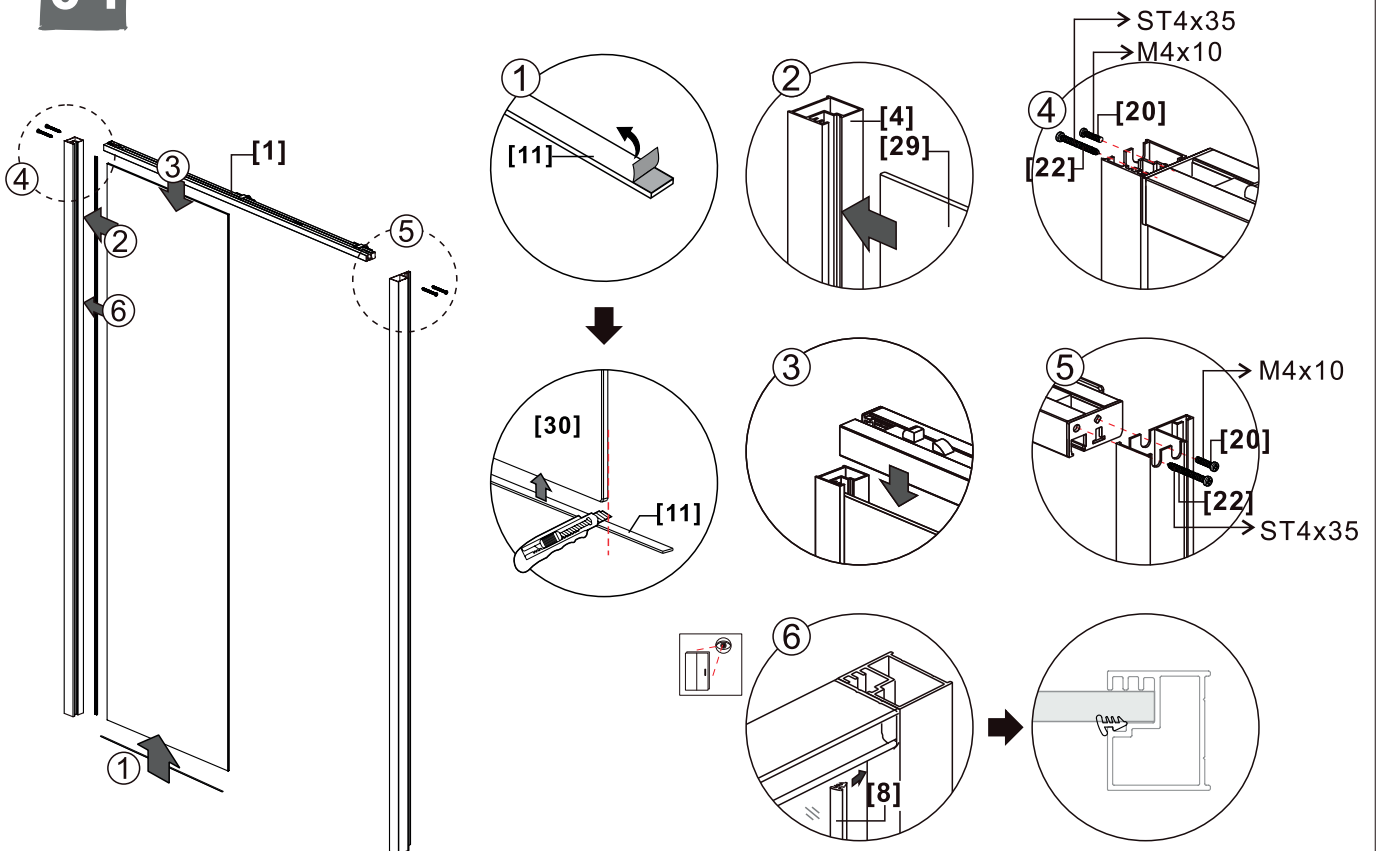

05

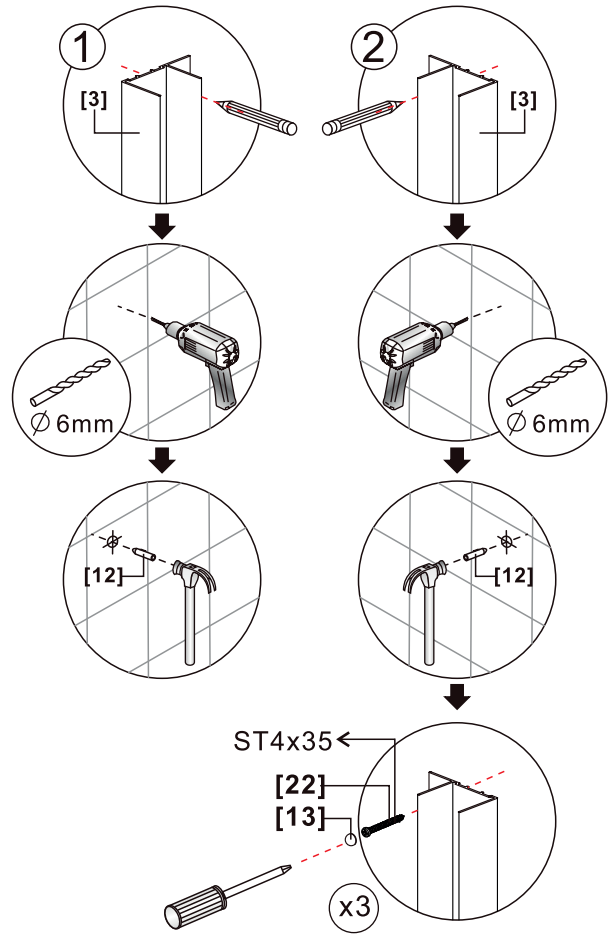
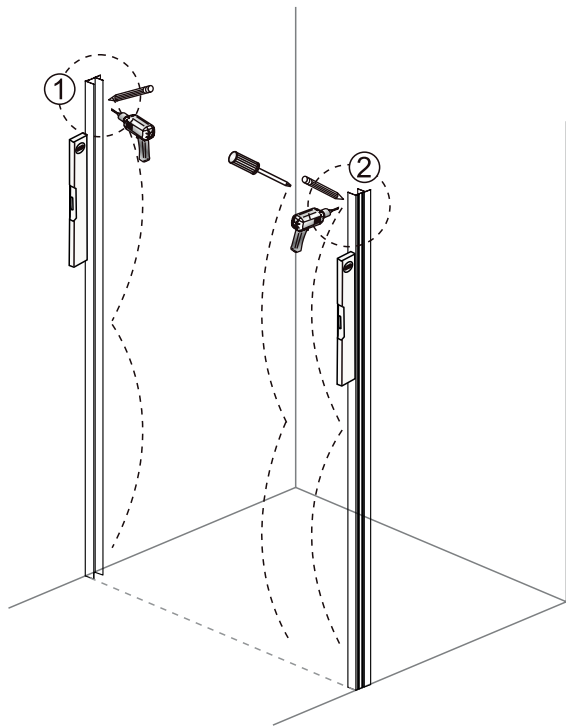

06

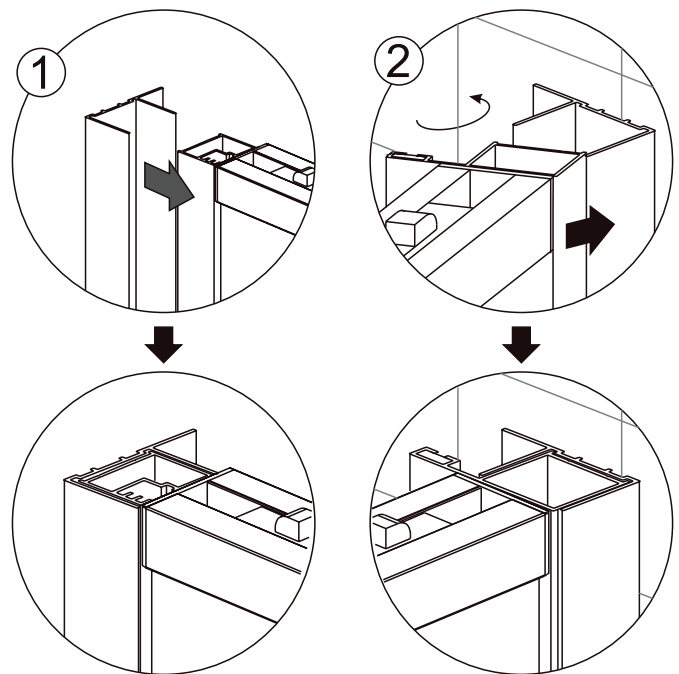
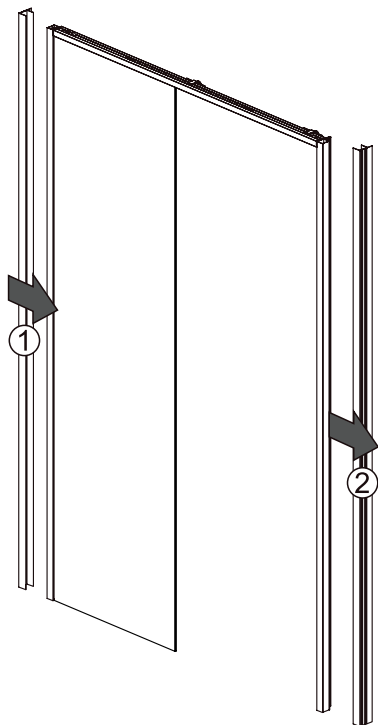

07

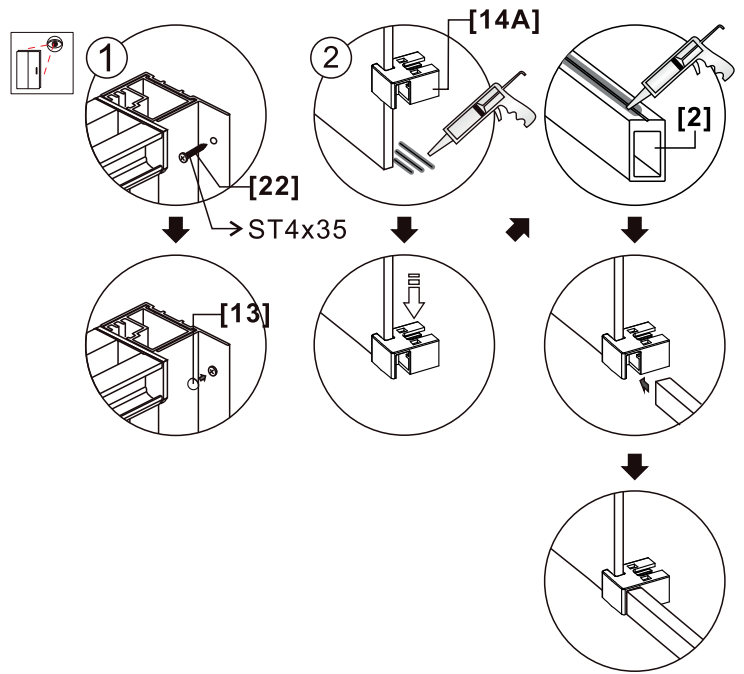
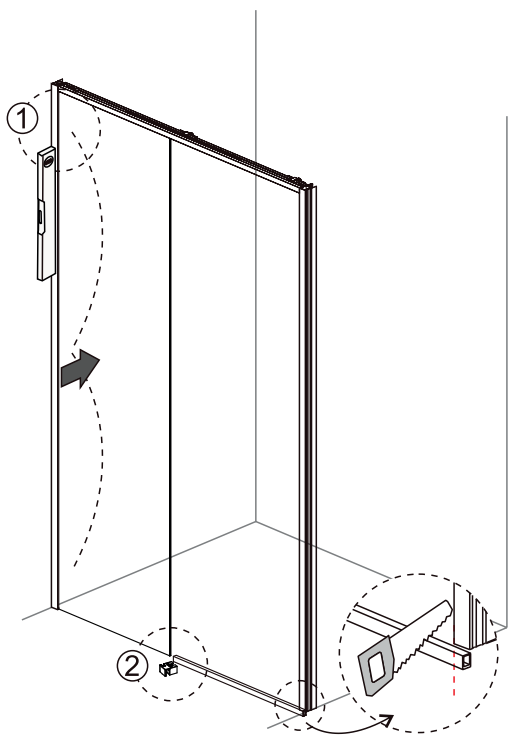

08

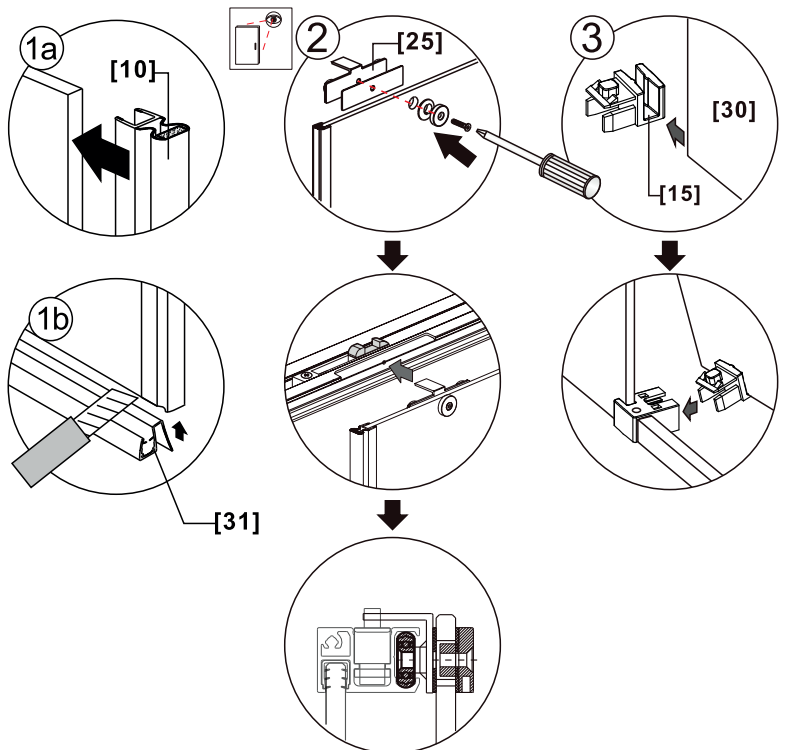
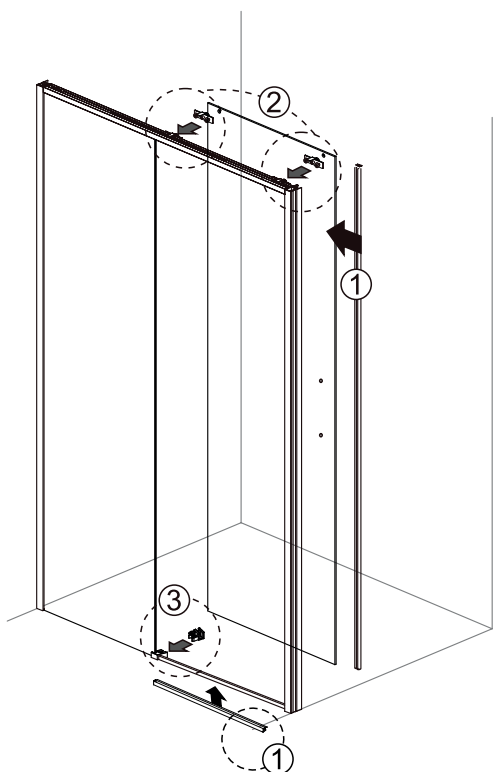

09

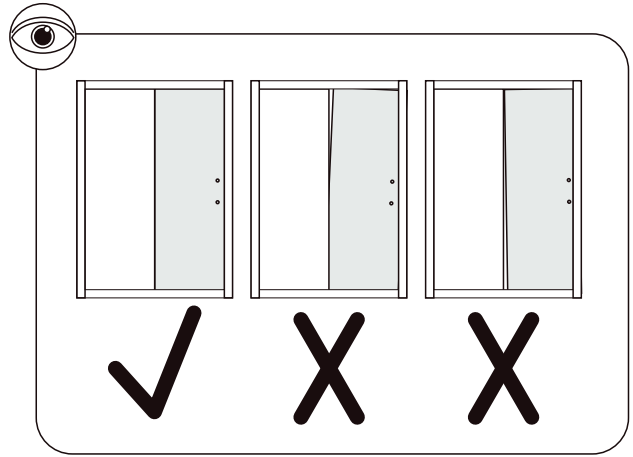
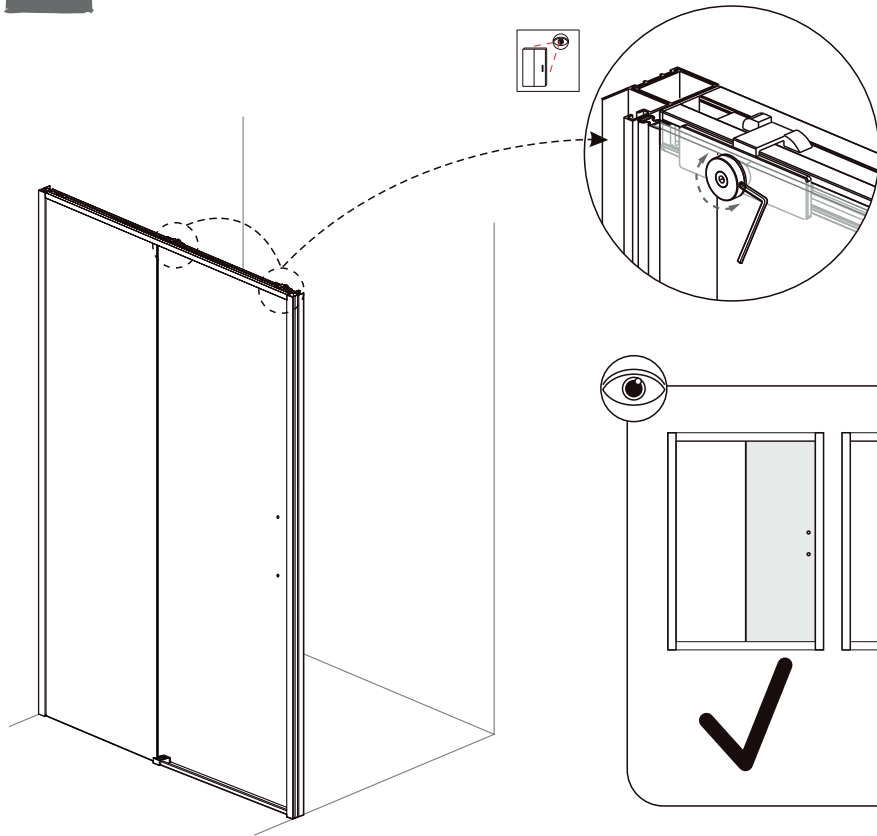

10

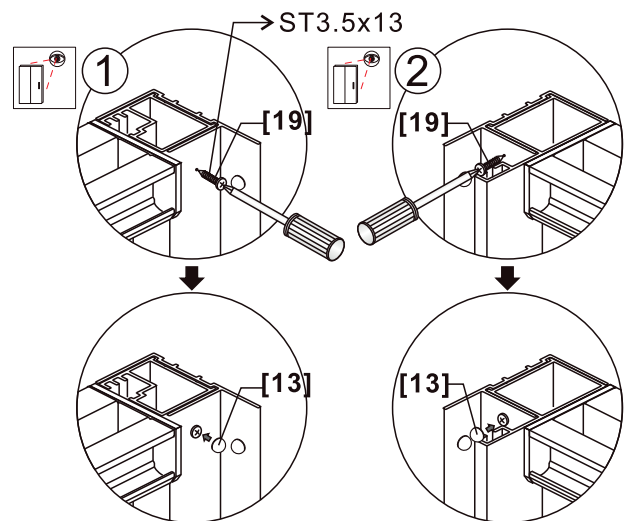
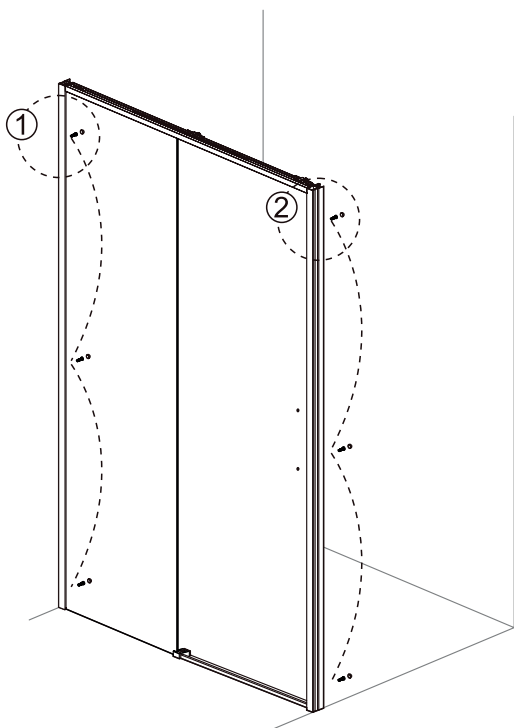

11

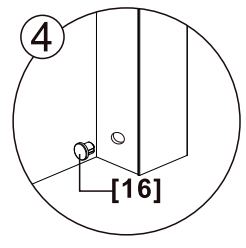
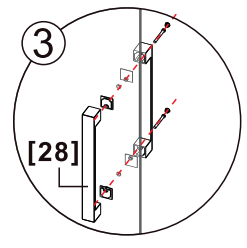
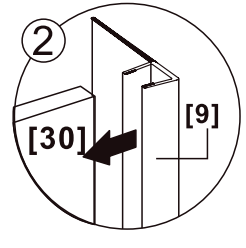
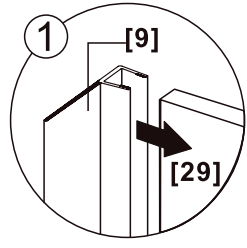
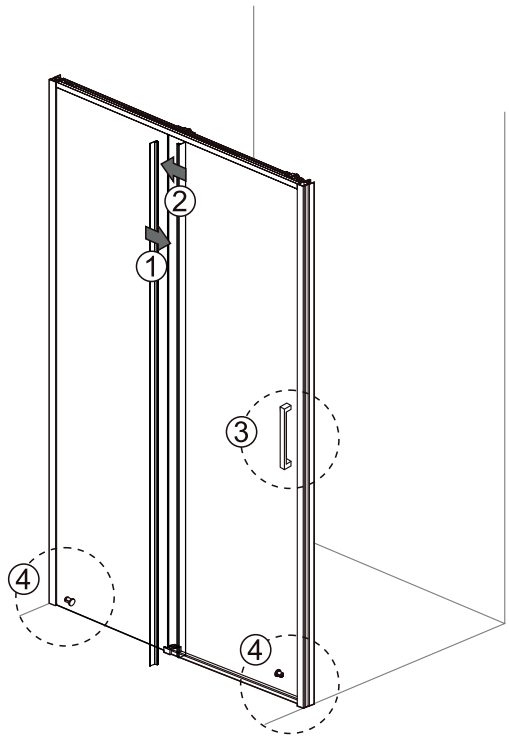

12

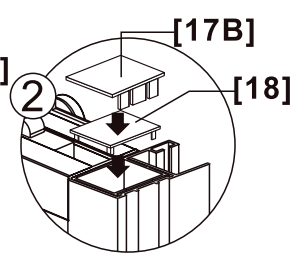
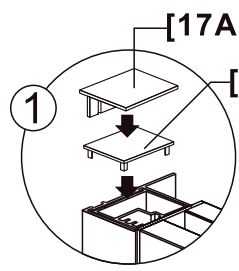
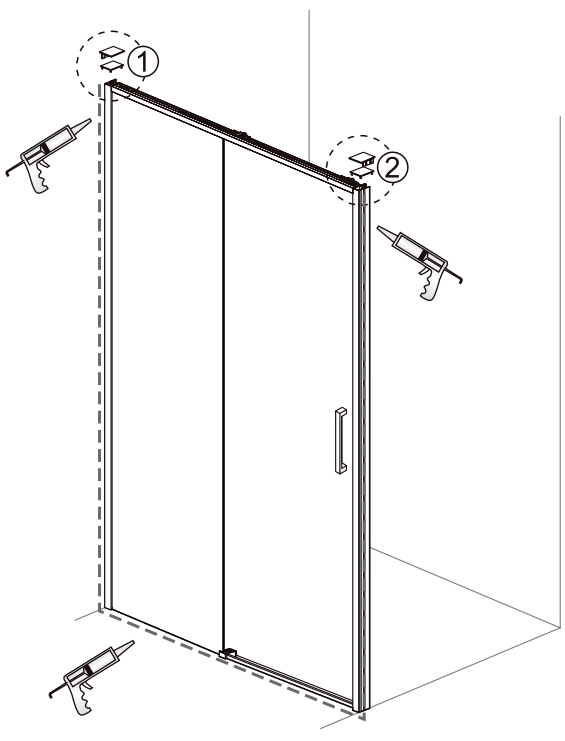

GME DIVISION BAÑOS S.L.
C/Inguda Comarques del País Valencià,
46930 - Quart de Poblet
Valencia - España

telf. 00 34 96 252 18 55
fax 00349 252 18 56
info@gmelorente.com
www.gmelorente.com

GME
DIVISIÓ BAÑOS