

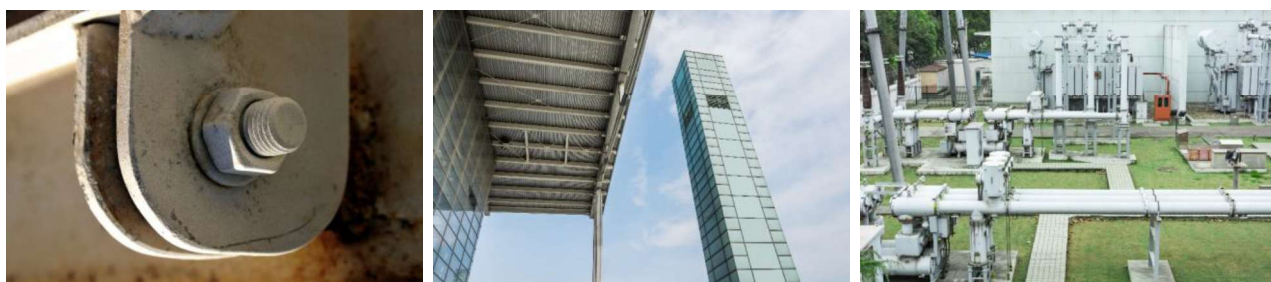











CARACTERÍSTICAS













- Tornillería para uniones mecánicas.
- Rosca métrica.
- Requiere taladro previo roscado, o bien el empleo de tuerca métrica.
- Variedad en métricas, cabezas y longitudes: flexibilidad en el montaje.
- Recubrimiento cincado e inoxidable.

APLICACIONES



1. GAMA

ITEM	CÓDIGO	NORMA	FOTO	CABEZA	HUELLA	MATERIAL
1	T084	DIN 84		 Cilíndrica	 Ranurada	Acero clase 4.8 UNE EN ISO 898-1. Recubrimiento: cincado $\geq 5 \mu\text{m}$ s/ISO 4042
2	T963	DIN 963		 Avellanada	 Ranurada	Acero clase 4.8 UNE EN ISO 898-1. Recubrimiento: cincado $\geq 5 \mu\text{m}$ s/ISO 4042
3	T965	DIN 965		 Avellanada	 Ph	Acero clase 4.8 UNE EN ISO 898-1. Recubrimiento: cincado $\geq 5 \mu\text{m}$ s/ISO 4042
4	T985	DIN 7985		 Alomada	 Ph	Acero clase 4.8 UNE EN ISO 898-1. Recubrimiento: cincado $\geq 5 \mu\text{m}$ s/ISO 4042
5	D931	DIN 931		 Hexagonal	 Hexagonal	Acero clase 8.8 UNE EN ISO 898-1. Recubrimiento: cincado $\geq 5 \mu\text{m}$ s/ISO 4042
6	D933	DIN 933		 Hexagonal	 Hexagonal	Acero clase 8.8 UNE EN ISO 898-1. Recubrimiento: cincado $\geq 5 \mu\text{m}$ s/ISO 4042
7	D933I	DIN 933 (A2)		 Hexagonal	 Hexagonal	Acero A2-70 (AISI 304)
8	D6921	DIN 6921		 Hexagonal brida	 Hexagonal	Acero clase 8.8 UNE EN ISO 898-1. Recubrimiento: cincado $\geq 5 \mu\text{m}$ s/ISO 4042
9	D6921I	DIN 6921 (A2)		 Hexagonal brida	 Hexagonal	Acero A2-70 (AISI 304)
10	D7380	DIN 7380		 Redonda	 Allen	Acero clase 10.9 UNE EN ISO 898-1. Recubrimiento: cincado $\geq 5 \mu\text{m}$ s/ISO 4042
11	D912	DIN 912		 Cilíndrica	 Allen	Acero clase 8.8 UNE EN ISO 898-1. Recubrimiento: cincado $\geq 5 \mu\text{m}$ s/ISO 4042
12	D603	DIN 603		 Redonda cuello cuadrado	 Inviolable	Acero clase 4.8 UNE EN ISO 898-1. Recubrimiento: cincado $\geq 5 \mu\text{m}$ s/ISO 4042
13	D603I	DIN 603 (A2)		 Redonda cuello cuadrado	 Inviolable	Acero A2-70 (AISI 304)
14	D608	DIN 608		 Avellanada	 Cilíndrica	Acero clase 8.8 UNE EN ISO 898-1. Recubrimiento: bricromatado $\geq 3 \mu\text{m}$ s/ISO 4042

ITEM	CÓDIGO	NORMA	FOTO	CABEZA	HUELLA	MATERIAL
15	D934	DIN 934		 Hexagonal		Acero dureza > 140 HV. Recubrimiento: cincado $\geq 5 \mu\text{m}$ s/ISO 4042
16	D934I	DIN 934 (A2)		 Hexagonal		Acero A2-70 (AISI 304)
17	D985	DIN 985		 Hexagonal		Acero dureza > 140 HV. Recubrimiento: cincado $\geq 5 \mu\text{m}$ s/ISO 4042
18	D985I	DIN 985 (A2)		 Hexagonal		Acero A2-70 (AISI 304)
19	D1587	DIN 1587		 Hexagonal		Acero al carbono Recubrimiento: cincado $\geq 5 \mu\text{m}$ s/ISO 4042
20	D6923	DIN 6923		 Hexagonal		Acero al carbono Recubrimiento: cincado $\geq 5 \mu\text{m}$ s/ISO 4042
21	D6923I	DIN 6923 (A2)		 Hexagonal		Acero A2-70 (AISI 304)
22	TU-MA	Equivalente DIN 315		--		Acero al carbono Recubrimiento: cincado $\geq 5 \mu\text{m}$ s/ISO 4042
23	D125	DIN 125		--		Acero dureza > 140 HV. Recubrimiento: cincado $\geq 5 \mu\text{m}$ s/ISO 4042
24	D125I	DIN 125 (A2)		--		Acero A2-70 (AISI 304)
25	D127	DIN 127		--		Acero clase 6 UNE EN 20898-2. Recubrimiento: cincado $\geq 5 \mu\text{m}$ s/ISO 4042
26	D127I	DIN 127 (A2)		--		Acero A2-70 (AISI 304)
27	D9021	DIN 9021		--		Acero clase 6 UNE EN 20898-2. Recubrimiento: cincado $\geq 5 \mu\text{m}$ s/ISO 4042
28	D9021I	DIN 9021 (A2)		--		Acero A2-70 (AISI 304)

ITEM	CÓDIGO	NORMA	FOTO	CABEZA	HUELLA	MATERIAL
29	D6798A	DIN 6798			--	Acero al carbono Recubrimiento: cincado $\geq 5 \mu\text{m}$ s/ISO 4042
30	TPMT	--			 Hexagonal	Polietileno (PE)

2. CARACTERÍSTICAS

2.1 DIN-84

Tornillo ranurado, cabeza cilíndrica



Propiedades



Acero



Recubrimiento cincado

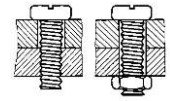

Unión chapas

Propiedades



Ranura



Cabeza cilíndrica

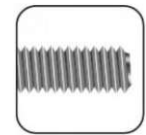

Métrica

MÉTRICA		M3	M4	M5	M6
Ød2: diámetro cabeza	[mm]	5.5	7	8.5	10
k: espesor cabeza	[mm]	2.0	2.6	3.3	3.9
n: anchura ranura	[mm]	1.0	1.50	1.50	1.9
t: profundidad ranura	[mm]	1.15	1.5	1.8	2.2

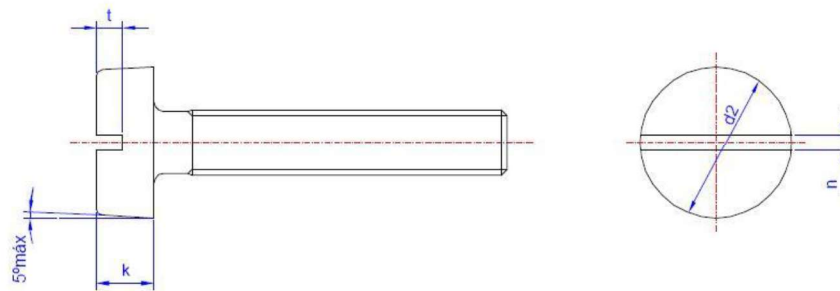

2.2 DIN-963

Tornillo ranurado con cabeza avellanada



Propiedades



Acero



Recubrimiento
cincado

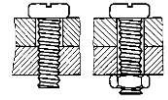

Unión chapas

Propiedades



Ranura



Cabeza avellanada

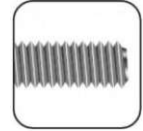

Métrica

MÉTRICA		M4	M5	M6	M8
Ød2: diámetro cabeza	[mm]	7.5	9.2	11	14.5
k: espesor cabeza	[mm]	2.2	2.5	3	4
n: anchura ranura	[mm]	1.5	1.5	1.9	2.3
t: profundidad ranura	[mm]	1.1	1.3	1.6	2.1

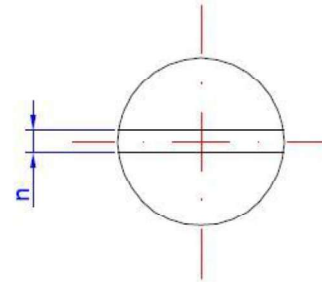
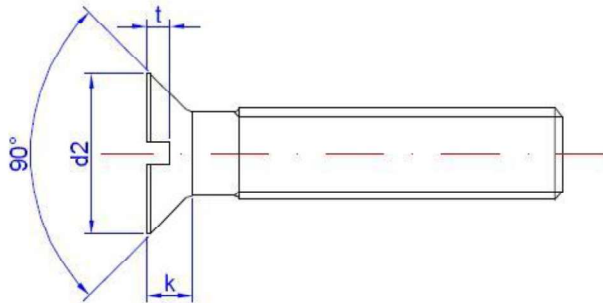

2.3 DIN-965

Tornillo de cabeza avellanada y huella Ph



Propiedades



Acero



Recubrimiento
cincado

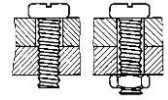

Unión chapas

Propiedades



Ph



Cabeza avellanada

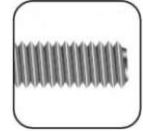

Métrica

MÉTRICA		M3	M4	M5	M6
Ød2: diámetro cabeza	[mm]	5.6	7.5	9.2	11.0
k: espesor cabeza	[mm]	1.65	2.2	2.5	3.0
Hueco Ph		1	2	2	3
Punta colocación		PUPHC01 PUPHL01	PUPHC02 PUPHL002	PUPHC02 PUPHL02	PUPHC03 PUPHL03

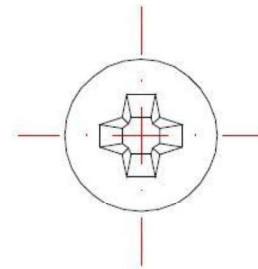
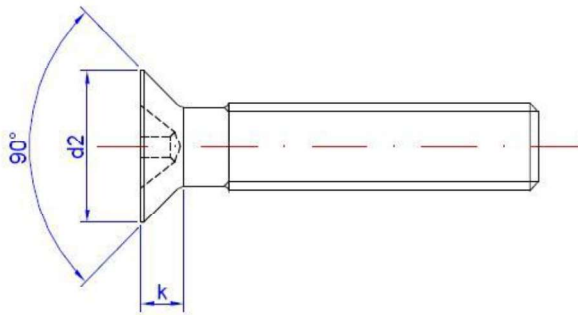

2.4 DIN-7985

Tornillo de cabeza alomada y huella Ph



Propiedades



Acero



Recubrimiento
cincado

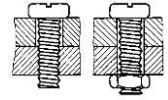

Unión chapas

Propiedades



Ph

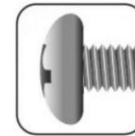

Cabeza alomada

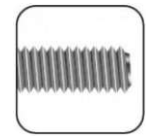

Métrica

MÉTRICA		M3	M4	M5	M6
Ød2: diámetro cabeza	[mm]	6	8	10	12
k: espesor cabeza	[mm]	2.4	3.1	3.8	4.6
v	[mm]	1.6	2.0	2.5	3.0
Hueco Ph		1	2	2	3
Punta colocación		PUPHC01 PUPHL01	PUPHC02 PUPHL002	PUPHC02 PUPHL02	PUPHC03 PUPHL03

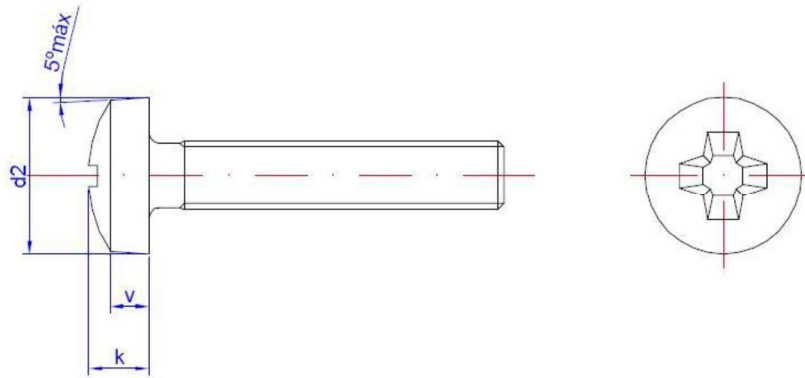

2.5 DIN-931

Tornillo rosca métrica hexagonal



Propiedades



Acero



Recubrimiento
cincado

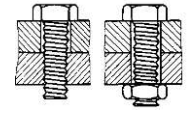

Unión chapas

Propiedades



Hexagonal



Cabeza hexagonal

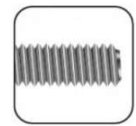

Métrica

MÉTRICA		M6	M8	M10	M12	M14	M16	M18	M20
s: distancia entre caras	[mm]	10	13	17	19	22	24	27	30
k: espesor cabeza	[mm]	4	5,3	6,4	7,5	8,8	10	11,5	12,5
e: distancia entre vértices	[mm]	10,89	14,20	18,72	20,88	23,91	26,17	29,56	32,95
b(min): longitud de rosca $l \leq 120$ mm	[mm]	18	22	26	30	34	38	42	46
b(min): longitud de rosca $l > 120$ mm	[mm]	--	28	32	36	40	44	48	52
Llave de instalación		10	13	17	19	22	24	27	30

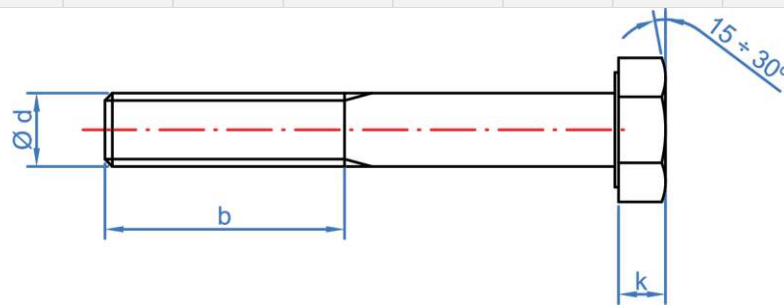
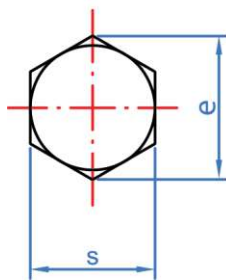

2.6 DIN-933

Tornillo rosca métrica hexagonal



Propiedades



Acero



Recubrimiento
cincado

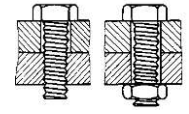

Unión chapas

Propiedades



Hexagonal



Cabeza hexagonal

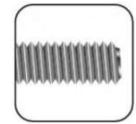

Métrica

MÉTRICA		M4	M5	M6	M8	M10	M12	M14	M16	M18	M20
s: distancia entre caras	[mm]	7	8	10	13	17	19	22	24	27	30
k: espesor cabeza	[mm]	3	3,5	4	5,3	6,4	7,5	8,8	10	11,5	12,5
e: distancia entre vértices	[mm]	7,50	8,63	10,89	14,20	18,72	20,88	23,91	26,17	29,56	32,95
Llave de instalación		7	8	10	13	17	19	22	24	27	30

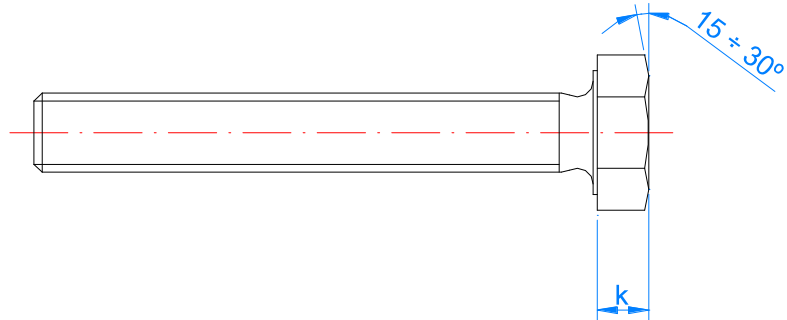
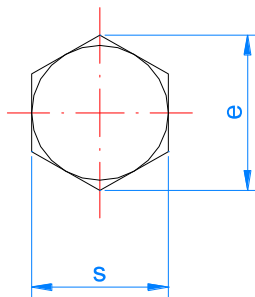

2.7 DIN-933 A2

Tornillo rosca métrica hexagonal inoxidable

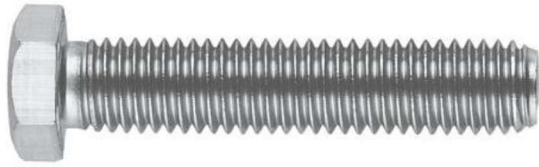

Propiedades



Acero



Recubrimiento
cincado

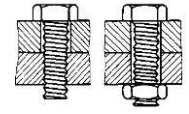

Unión chapas

Propiedades



Hexagonal



Cabeza hexagonal

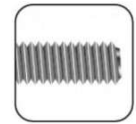

Métrica

MÉTRICA		M4	M5	M6	M8	M10	M12	M14	M16	M18
s: distancia entre caras	[mm]	7	8	10	13	17	19	22	24	27
k: espesor cabeza	[mm]	3	3,5	4	5,3	6,4	7,5	8,8	10	11,5
e: distancia entre vértices	[mm]	7,50	8,63	10,89	14,20	18,72	20,88	23,91	26,17	29,56
Llave de instalación		7	8	10	13	17	19	22	24	27

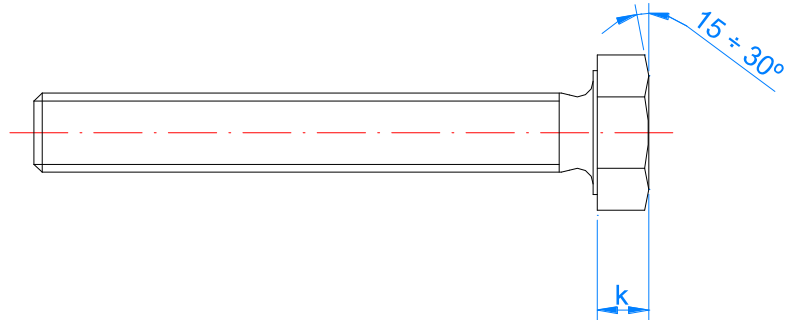
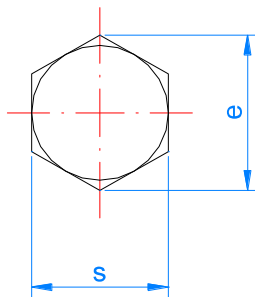

2.8 DIN-6921

Tornillo rosca métrica hexagonal con arandela estampada



Propiedades



Acero



Recubrimiento
cincado

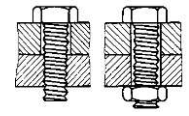

Unión chapas

Propiedades



Hexagonal



Cabeza hexagonal

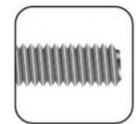

Métrica

MÉTRICA		M5	M6	M8	M10	M12
s: distancia entre caras	[mm]	8	10	13	17	19
k: espesor cabeza	[mm]	5,4	6,6	8,10	9,2	11,5
e: distancia entre vértices	[mm]	8,71	10,95	14,26	16,50	17,62
Ødc: diámetro de arandela	[mm]	11,8	14,2	18,0	22,3	26,6
b(min): longitud de rosca	[mm]	Completa / 16 min	Completa / 18 min	Completa / 22 min	Completa / 26 min	Completa / 30 min
Llave de instalación		8	10	13	17	19

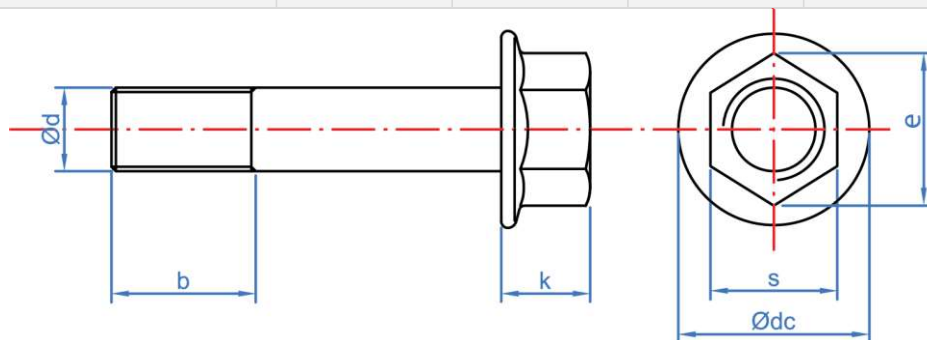

2.9 DIN-6921 A2

Tornillo rosca métrica hexagonal con arandela inoxidable



Propiedades



Acero



Inoxidable A2-70
(AISI 304)

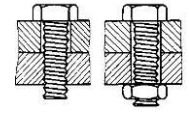

Unión chapas

Propiedades



Hexagonal



Cabeza hexagonal

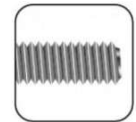

Métrica

MÉTRICA		M5	M6	M8	M10	M12
s: distancia entre caras	[mm]	8	10	13	17	19
k: espesor cabeza	[mm]	5,4	6,6	8,10	9,2	11,5
e: distancia entre vértices	[mm]	8,71	10,95	14,26	16,50	17,62
Ødc: diámetro de arandela	[mm]	11,8	14,2	18,0	22,3	26,6
b(min): longitud de rosca	[mm]	Completa / 16 min	Completa / 18 min	Completa / 22 min	Completa / 26 min	Completa / 30 min
Llave de instalación		8	10	13	17	19

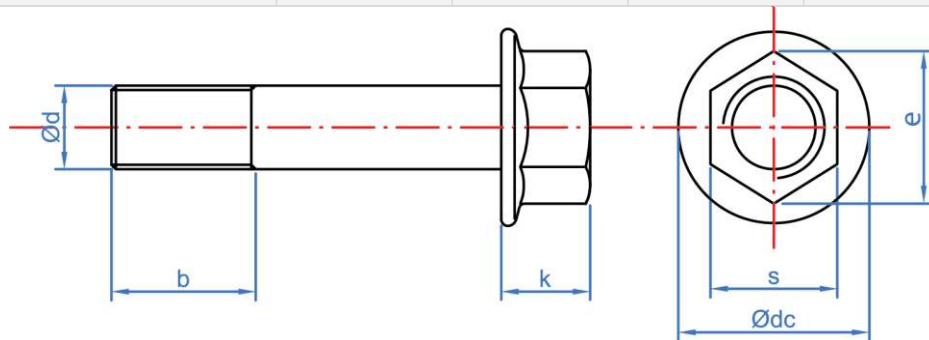

2.10 DIN-7380

Tornillo ISO 7380 con huella Allen y cabeza redonda

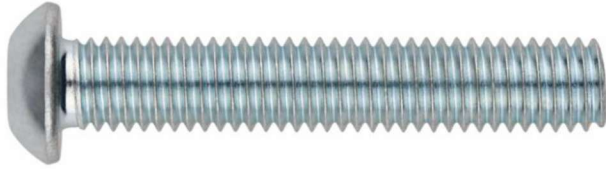

Propiedades



Acero



Recubrimiento
cincado

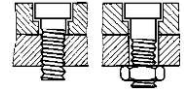

Unión chapas

Propiedades



Allen

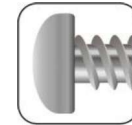

Cabeza redonda



Métrica

MÉTRICA		M3	M4	M5	M6	M8	M10
Ødk: diámetro de la cabeza	[mm]	5,50	7,50	9,30	10,30	13,75	17,30
k: espesor cabeza	[mm]	1,50	2,00	2,50	3,00	4,10	5,20
L: Longitudes disponibles	[mm]	12 - 20	8 - 40	10 - 50	8 - 60	10 - 60	16 - 60
Llave de instalación		Allen 2	Allen 2.5	Allen 3	Allen 4	Allen 5	Allen 6

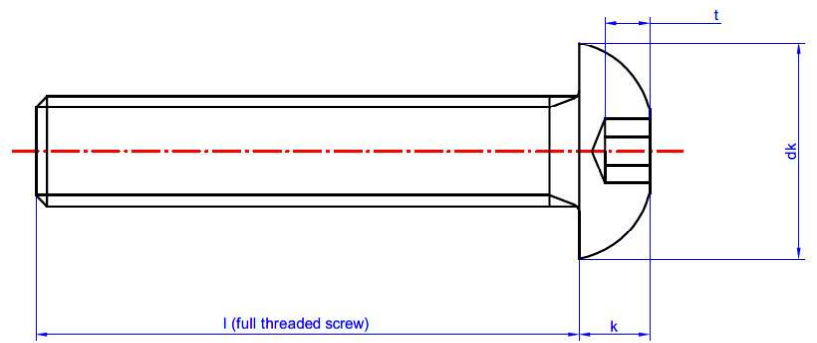
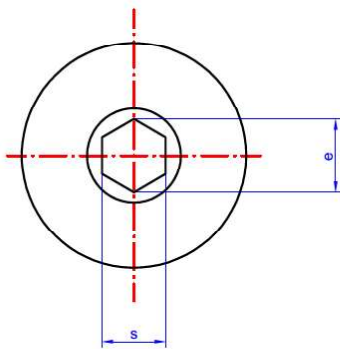

2.11 DIN-912

Tornillo Allen



Propiedades



Acero



Recubrimiento cincado

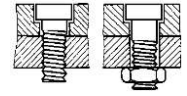

Unión chapas

Propiedades



Allen



Cabeza cilíndrica

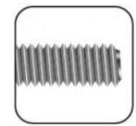

Métrica

MÉTRICA		M4	M5	M6	M8	M10	M12
Ødk: diámetro de la cabeza	[mm]	7	8,5	10	13	16	18
s: distancia entre caras de la huella	[mm]	3	4	5	6	8	10
k: espesor cabeza	[mm]	4	5	6	8	10	12
Llave de instalación		Allen 3	Allen 4	Allen 5	Allen 6	Allen 8	Allen 10

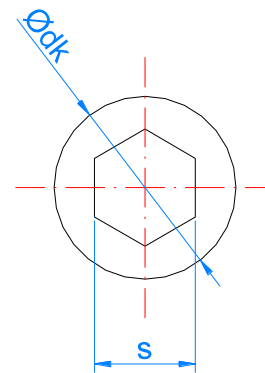
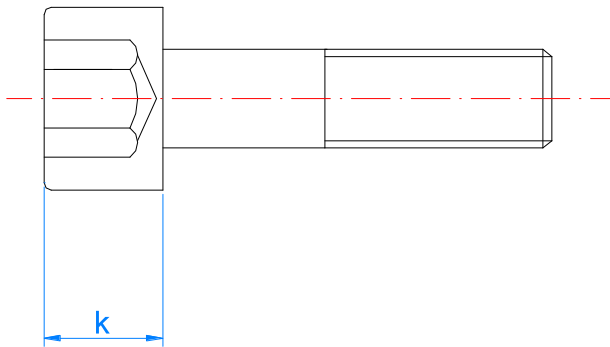

2.12 DIN-603

Tornillo DIN-603 y tuerca DIN-934



Propiedades



Acero



Recubrimiento
cincado

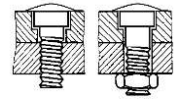

Unión chapas

Propiedades



Cabeza redonda cuello cuadrado

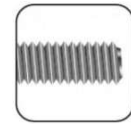

Métrica

MÉTRICA		M5	M6	M8	M10	M12
Ødk: diámetro cabeza	[mm]	13	16	20	24	30
k: espesor cabeza	[mm]	3	3,5	4,5	5	6,5
a: espesor del cuadrado	[mm]	3,5	4	5	6	8
s	[mm]	5	6,2	7,8	9,85	11,6
c	[mm]	5	6	8	10	12

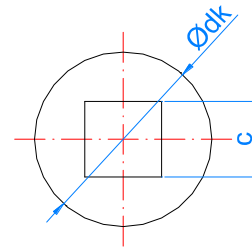
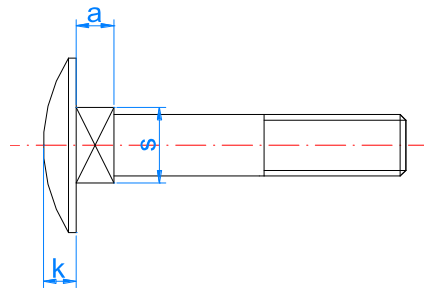

2.13 DIN-603 A2

Tornillo DIN-603 inoxidable



Propiedades



Acero



Inoxidable A2-70 (AISI 304)

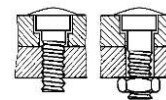

Unión chapas

Propiedades



Cabeza redonda cuello cuadrado

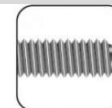

Métrica

MÉTRICA		M5	M6	M8	M10	M12
Ødk: diámetro cabeza	[mm]	13	16	20	24	30
k: espesor cabeza	[mm]	3	3,5	4,5	5	6,5
a: espesor del cuadrado	[mm]	3,5	4	5	6	8
s	[mm]	5	6,2	7,8	9,85	11,6
c	[mm]	5	6	8	10	12

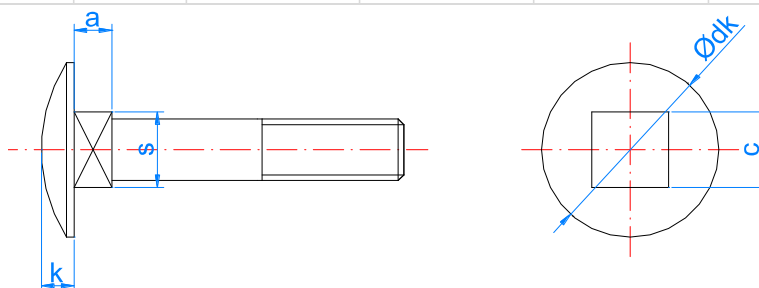

2.14 DIN-608

Tornillo DIN-608 y tuerca DIN-934



Propiedades



Acero



Recubrimiento bicromatado

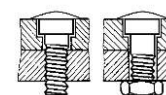

Unión chapas

Propiedades



Cabeza avellanada

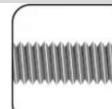

Métrica

MÉTRICA		M10	M10	M12
Ødk: diámetro cabeza	[mm]	19,5	21,5	23,5
b: longitud de rosca	[mm]	25	27	28,5
d: métrica	[mm]	10	11	12

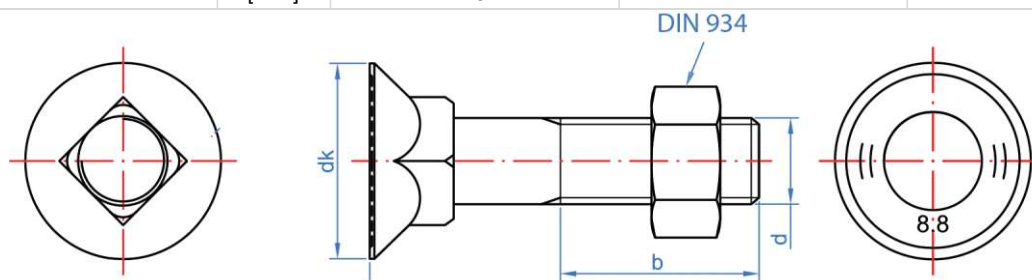

2.15 DIN-934

Tuerca hexagonal

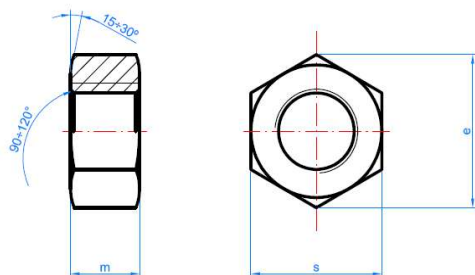

Propiedades



Acero

Recubrimiento
cincado

M	M3	M4	M5	M6	M8	M10	M12	M14	M16	M18	M20	M22	M24	M27	M30	M33	M36
s	5,5	7	8	10	13	17	19	22	24	27	30	32	36	41	46	50	55
e	6,0	7,7	8,8	11,1	14,4	18,9	21,1	24,5	26,8	29,6	32,9	35,0	39,6	45,2	50,9	55,4	60,8
m	2,4	3,2	4	5	6,5	8	10	11	13	15	16	18	19	22	24	26	29
Llave	5,5	7	8	10	13	17	19	22	24	27	30	32	36	41	46	50	55

2.16 DIN-934 A2

Tuerca hexagonal inoxidable

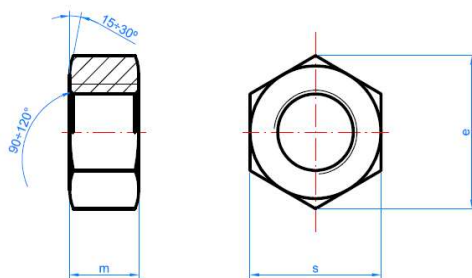

Propiedades



Acero

Inoxidable A2
(AISI 304)

M	M4	M5	M6	M8	M10	M12	M14	M16	M18	M20	M22	M24
s	7	8	10	13	17	19	22	24	27	30	32	36
e	7,7	8,8	11,1	14,4	18,9	21,1	24,5	26,8	29,6	32,9	35,0	39,6
m	3,2	4	5	6,5	8	10	11	13	15	16	18	19
Llave	7	8	10	13	17	19	22	24	27	30	32	36

2.17 DIN-985

Tuerca autoblocante

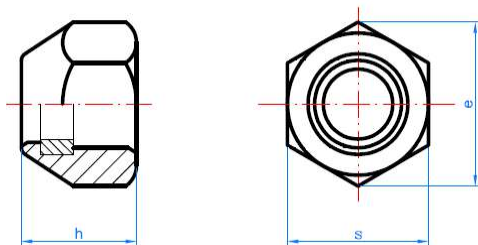

Propiedades



Acero

Recubrimiento
cincado

M	M3	M4	M5	M6	M8	M10	M12	M14	M16	M18	M20	M22	M24	M27	M30
s	5,5	7	8	10	13	17	19	22	24	27	30	32	36	41	46
e	6,0	7,7	8,8	11,1	14,4	18,9	21,1	24,5	26,8	29,6	32,9	35,0	38,6	45,2	50,9
h	4	5	5	6	8	10	12	14	16	18,5	20	22	24	27	30
Llave	5,5	7	8	10	13	17	19	22	24	27	30	32	36	41	46

2.18 DIN-985 A2

Tuerca autoblocante inoxidable A2

Propiedades

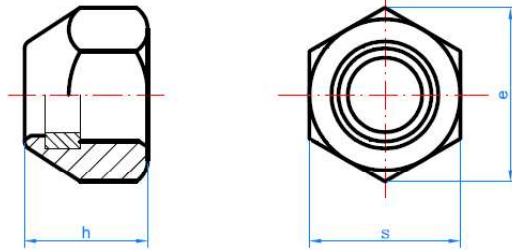

Acero

Inoxidable A2
(AISI 304)

M	M4	M5	M6	M8	M10	M12	M14	M16	M18	M20	M22	M24
s	7	8	10	13	17	19	22	24	27	30	32	36
e	7,7	8,8	11,1	14,4	18,9	21,1	24,5	26,8	29,6	32,9	35,0	38,6
h	5	5	6	8	10	12	14	16	18,5	20	22	24
Llave	7	8	10	13	17	19	22	24	27	30	32	36

2.19 DIN-1587

Tuerca ciega

Propiedades

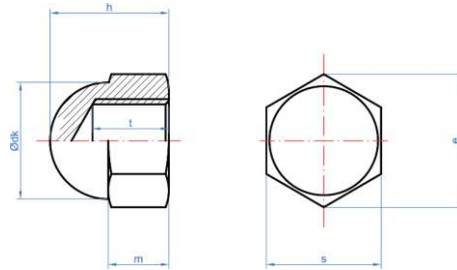

Acero

Recubrimiento
cincado

M	M4	M5	M6	M8	M10	M12	M14	M16
s	7	8	10	13	17	19	22	24
e	7,7	8,8	11,1	14,4	18,9	21,1	24,5	26,8
h	8	10	12	15	18	22	25	28
m	3	4	5	6,5	8	10	11	13
t	5,5	7,5	8	11	13	16	18	21
Ødk	6,5	7,5	9,5	12,5	16	18	21	23
Llave	7	8	10	13	17	19	22	24

2.20 DIN-6923

Tuerca brida grafilada

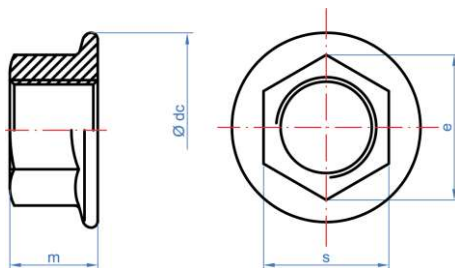

Propiedades



Acero

Recubrimiento
cincado

M	M4	M5	M6	M8	M10	M12	M14	M16
s	7	8	10	13	15	18	21	24
e	7,7	8,8	11,1	14,4	18,9	21,1	24,5	26,8
m	4,5	5	6	8	10	12	14	16
ØdC	10	11,8	14,2	17,9	21,8	26	29,9	34,5
Llave	7	8	10	13	17	19	22	24

2.21 DIN-6923 A2

Tuerca brida grafilada inoxidable

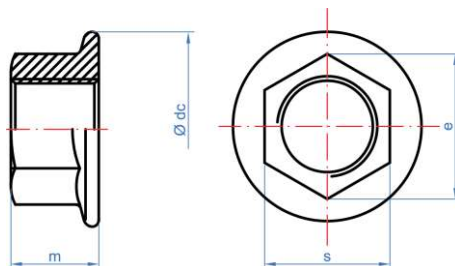

Propiedades



Acero

Inoxidable A2
(AISI 304)

M	M4	M5	M6	M8	M10	M12	M14	M16
s	7	8	10	13	15	18	21	24
e	7,7	8,8	11,1	14,4	18,9	21,1	24,5	26,8
m	4,5	5	6	8	10	12	14	16
ØdC	10	11,8	14,2	17,9	21,8	26	29,9	34,5
Llave	7	8	10	13	17	19	22	24

2.22 TU-MA

Tuerca mariposa

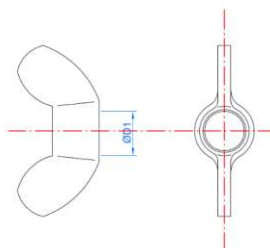

Propiedades





Acero

Recubrimiento
cincado

M	M3	M4	M5	M6	M8	M10	M12	M14	M16
ØD1: diámetro interior	M3	M4	M5	M6	M8	M10	M12	M14	M16

2.23 DIN-125												Arandela plana					
												Propiedades					
																	
												Acero			Recubrimiento cincado		
M	M3	M4	M5	M6	M8	M10	M12	M14	M16	M18	M20	M22	M24	M27	M30	M33	M36
Ød1: diámetro interior	3,3	4,3	5,3	6,4	8,4	10,5	13,0	15,0	17,0	19,0	21,0	23,0	25,0	28,0	31,0	34,0	37,0
Ød2: diámetro exterior	7	9	10	12	16	20	24	28	30	34	37	39	44	50	56	60	66
h: espesor	0,8	0,8	1	1,6	1,6	2	2,5	2,5	3	3	3	3	4	4	4	5	5

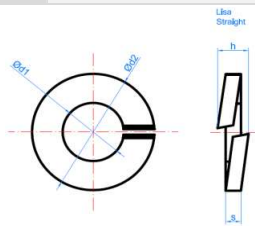
2.24 DIN-125 A2												Arandela plana inoxidable					
												Propiedades					
																	
												(AISI 304)			Acero Inoxidable A2		
M	M4	M5	M6	M8	M10	M12	M14	M16	M18	M20	M22	M24					
Ød1: diámetro interior	4,3	5,3	6,4	8,4	10,5	13,0	15,0	17,0	19,0	21,0	23,0	25,0					
Ød2: diámetro exterior	9	10	12	16	20	24	28	30	34	37	39	44					
h: espesor	0,8	1	1,6	1,6	2	2,5	2,5	3	3	3	3	4					

2.25 DIN-127												Arandela muelle Grower					
												Propiedades					
																	
												Acero			Recubrimiento cincado		
M	M3	M4	M5	M6	M8	M10	M12	M14	M16	M18	M20	M22	M24	M27	M30	M36	
Ød1: diámetro interior	3,1	4,1	5,1	6,1	8,1	10,2	12,2	14,2	16,2	18,2	20,2	22,5	24,5	27,5	30,5	36,5	
Ød2: diámetro exterior	6,2	7,6	9,2	11,8	14,8	18,1	21,1	24,1	27,4	29,4	33,6	35,9	40	43	48,2	58,2	
h: anchura lisa	1,8	2	2,6	3,3	4,3	4,8	5,4	6,5	7,6	7,7	8,7	8,7	10,9	10,9	13,1	13,1	
s: espesor	0,8	0,9	1,2	1,6	2	2,2	2,5	3	3,5	3,5	4	4	5	5	6	6	

2.26 DIN-127 A2

Arandela muelle Grower inoxidable

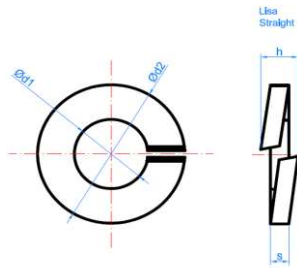

Propiedades



Acero

Inoxidable A2
(AISI 304)

M	M3	M4	M5	M6	M8	M10	M12	M14	M16	M18	M20	M22	M24	M27	M30	M36
Ød1: diámetro interior	3,1	4,1	5,1	6,1	8,1	10,2	12,2	14,2	16,2	18,2	20,2	22,5	24,5	27,5	30,5	36,5
Ød2: diámetro exterior	6,2	7,6	9,2	11,8	14,8	18,1	21,1	24,1	27,4	29,4	33,6	35,9	40	43	48,2	58,2
h: anchura lisa	1,8	2	2,6	3,3	4,3	4,8	5,4	6,5	7,6	7,7	8,7	8,7	10,9	10,9	13,1	13,1
s: espesor	0,8	0,9	1,2	1,6	2	2,2	2,5	3	3,5	3,5	4	4	5	5	6	6

2.27 DIN-9021

Arandela plana ancha

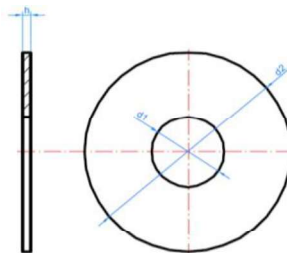

Propiedades



Acero

Recubrimiento
cincado

M	M3	M4	M5	M6	M8	M10	M12	M14	M16	M18	M20	M22	M24
Ød1: diámetro interior	3,2	4,3	5,3	6,4	8,4	10,5	13,0	15,0	17,0	20,0	22,0	24,0	26,0
Ød2: diámetro exterior	9	12	15	18	24	30	37	44	50	56	60	66	72
h: espesor	0,8	1	1,2	1,6	2	2,5	3	3	3	4	4	5	5

2.28 DIN-9021 A2

Arandela plana ancha inoxidable

Propiedades



Acero

Inoxidable A2
(AISI 304)

M	M4	M5	M6	M8	M10	M12	M14	M16	M18	M20	M22	M24
Ød1: diámetro interior	4,3	5,3	6,4	8,4	10,5	13,0	15,0	17,0	20,0	22,0	24,0	26,0
Ød2: diámetro exterior	12	15	18	24	30	37	44	50	56	60	66	72
h: espesor	1	1,2	1,6	2	2,5	3	3	3	4	4	5	5

2.29 DIN-6798

Arandela dentada exterior

Propiedades



Acero

Recubrimiento
cincado

M	M3	M4	M5	M6	M8	M10	M12	M14	M16	
Ød1: diámetro interior	3,2	4,3	5,3	6,4	8,4	10,5	13	15	17	
Ød2: diámetro exterior	6	8	10	11	15	18	20,5	24	26	
s1: espesor	0,4	0,5	0,6	0,7	0,8	0,9	1	1	1,2	
s3: anchura	~3*s1									

2.30 TP-MT

Tapón plástico para cabeza hexagonal

Propiedades



Polietileno

M	M6	M8	M10	M12	M16
SW	10	13	17	19	24
ØD	12,5	15,5	20,5	23,5	29,5
H1	8,5	9,0	11,5	11,5	14,0
L1	14	15,5	20,5	21,5	27,0

3. PAR DE APRIETE PARA LOS TORNILLOS

Para tornillos y tuercas de acero la norma UNE 17-108-81 establece unos parámetros para la instalación específicos.

Esta norma tiene por objeto indicar el valor del momento de apriete necesario para montar, mediante herramientas dinamométricas que no introduzcan vibraciones ni impactos, la tornillería normal de acero, sobre apoyos rígidos y sometida únicamente a sollicitaciones axiales de valor constante.

Para uniones entre materiales cincados el coeficiente de rozamiento establecido por la norma es $\mu=0,14$. Los momentos de apriete para cada métrica están especificados en la tabla de abajo.

PAR DE APRIETE [da N·m] (con $\mu=0,14$)

ITEM	MÉTRICA										
	M3	M4	M5	M6	M8	M10	M12	M14	M16	M18	M20
T084	0,063	0,14	0,29	0,49	1,2	2,4	4,1	6,5	10	14	19,5
T963											
T965											
T985											
D603											
D931	0,12	0,27	0,54	0,93	2,2	4,5	7,7	12,5	19	27	38
D933											
D6921											
D912											
D933 (A2)*											
D603 (A2)*	0,10	0,17	0,34	0,59	1,45	3,00	5,00	7,90	12,10	17,40	22,40
D6921 (A2)*											

*Valores según DIN EN ISO 3506 para acero inoxidable A2-70 y coeficiente de rozamiento $\mu_{total}=0,10$. Estos valores son orientativos y dependerán siempre de que la tuerca y el tornillo tengan la lubricación adecuada.

4. RESISTENCIAS

La norma ISO-898-1 "Características mecánicas de los elementos de fijación fabricados de aceros al carbono y aceros aleados" establece unos valores de cargas mínimas de rotura a tracción.

De acuerdo a las tabla 6 de la norma mencionada se muestran los valores correspondientes a los tornillos anteriormente mostrados.

Los valores de resistencia a cortante son equivalentes al 50% de la resistencia a tracción.

*Cs: Coeficiente de seguridad.

CARGA DE ROTURA TEÓRICA A TRACCION [kN] ($A_s, \text{nom} \times R_{m, \text{min}}$)

ITEM	MÉTRICA										
	M3	M4	M5	M6	M8	M10	M12	M14	M16	M18	M20
T084											
T963											
T965	2,01	3,51	5,68	8,04	14,64	23,20	33,72	46,00	62,80	77,20	98,00
T985											
D603											
D608											
D931											
D933	4,02	7,02	11,36	16,08	29,28	46,40	67,44	92,00	125,60	154,40	196,00
D6921											
D912											
D933 (A2)											
D603 (A2)	3,52	6,15	9,94	14,07	25,62	40,60	59,01	80,50	109,90	135,10	171,50
D6921 (A2)											

CARGA MÁXIMA RECOMENDADA A TRACCIÓN [kN] ($A_s, \text{nom} \times R_{m, \text{min}}$) / (C_s^*)

ITEM	MÉTRICA										
	M3	M4	M5	M6	M8	M10	M12	M14	M16	M18	M20
T084											
T963											
T965	1,37	2,39	3,86	5,47	9,96	15,78	22,94	31,29	42,72	52,52	66,67
T985											
D603											
D608											
D931											
D933	2,74	4,78	7,73	10,94	19,92	31,56	45,88	62,59	85,44	105,03	133,33
D6921											
D912											
D933 (A2)											
D603 (A2)	2,40	4,18	6,76	9,57	17,43	27,62	40,14	54,76	74,76	91,90	116,67
D6921 (A2)											

CARGA DE ROTURA TEÓRICA A CORTANTE [kN] ($A_{s,nom} \times R_{m,min} \times 0,5$)

ITEM	MÉTRICA										
	M3	M4	M5	M6	M8	M10	M12	M14	M16	M18	M20
T084	1,01	1,76	2,84	4,02	7,32	11,60	16,86	23,00	31,40	38,60	49,00
T963											
T965											
T985											
D603											
D608	2,01	3,51	5,68	8,04	14,64	23,20	33,72	46,00	62,80	77,20	98,00
D931											
D933											
D6921											
D912											
D933 (A2)	1,76	3,07	4,97	7,04	12,81	20,30	29,51	40,25	54,95	67,55	85,75
D603 (A2)											
D6921 (A2)											

CARGA MÁXIMA RECOMENDADA A CORTANTE [kN] ($A_{s,nom} \times R_{m,min} \times 0,5$) / (C_s)

ITEM	MÉTRICA										
	M3	M4	M5	M6	M8	M10	M12	M14	M16	M18	M20
T084	0,68	1,19	1,93	2,73	4,98	7,89	11,47	15,65	21,36	26,26	33,33
T963											
T965											
T985											
D603											
D608	1,37	2,39	3,86	5,47	9,96	15,78	22,94	31,29	42,72	52,52	66,67
D931											
D933											
D6921											
D912											
D933 (A2)	1,20	2,09	3,38	4,79	8,71	13,81	20,07	27,38	37,38	45,95	58,33
D603 (A2)											
D6921 (A2)											