

AZUD Helix SYSTEM

AZUD HELIX SYSTEM is the manual filter series for exclusive use for irrigation water filtration application, based on high efficiency, with low maintenance and precision manufacturing in a safe environment.

AZUD HELIX device. The centrifugal action optimizes the filtration performance while reducing backwash frequency and maintenance.



ADVANTAGES

- ✓ **AZUD HELIX device.**
Helix created centrifugal action optimizes the filtration performance and reduces backwash frequency and maintenance.
- ✓ **Disc Filtration with maximum safety.**
Its patented design and high quality materials used in manufacturing guarantee an extended life with high resistance. High filtering surface. Filtration degrees 100, 130, 200 and 400 micron.

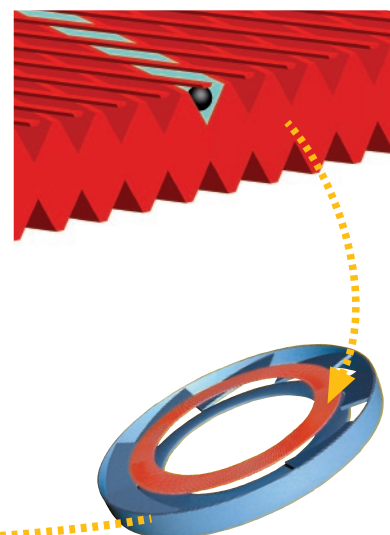

TECHNOLOGY

FILTRATION STAGE: The HELIX technology generates a centrifugal effect which pushes the particles in the dirty water away from the discs.

Keeping the larger particles away from the discs has two major advantages:

- It decreases the frequency of backwashing, thus minimizing the amount of water used.
- Allows the discs to concentrate on removal of the finer particles.

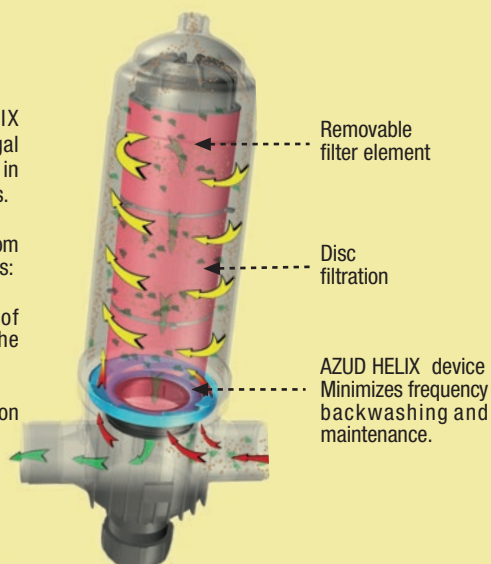

- ✓ **Modularity, versatility, compatibility.**
The system permits a wide range of flows and configurations using a minimal number of components.
- ✓ **Manufactured in plastic materials.**
- ✓ **Low Maintenance.**
Simple with no tools required. Maximum wear resistance of high quality moving parts.
- ✓ **The exclusive Butterfly System** used for locking the filter elements allows for easy decompression of the disc stack during backwash. It also allows easy handling and disc maintenance.
- ✓ **Water and energy saving.**

AZUD HELIX SYSTEM

AZUD HELIX SYSTEM 130 micron	Max. flow	Filtering surface
		Discs
2N	30 m ³ /h 132 gpm	1198 cm ² 186 in ²
2S	30 m ³ /h 132 gpm	1699 cm ² 263 in ²
3N	50 m ³ /h 220 gpm	1699 cm ² 263 in ²
4N	70 m ³ /h 308 gpm	2396 cm ² 371 in ²
4S	100 m ³ /h 440 gpm	3398 cm ² 527 in ²

Other filtration degrees available. Consult www.azud.com.

MANUFACTURING MATERIAL

Housing	Polyamide reinforced with fiberglass
Filtering element	MG discs polypropylene / WS discs HDPE
Clamp	Stainless steel
Sealing element	NBR

4 < pH < 11 • Maximum pressure 10 bar / 145 psi • Maximum temperature 60 °C / 140 °F

AZUD HELIX SYSTEM

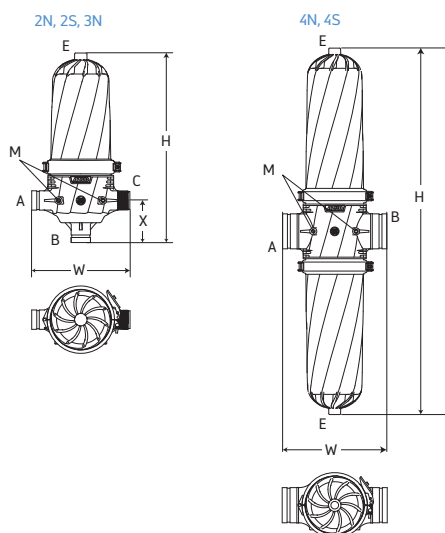

AZUD HELIX SYSTEM HEAD LOSS

130 micron

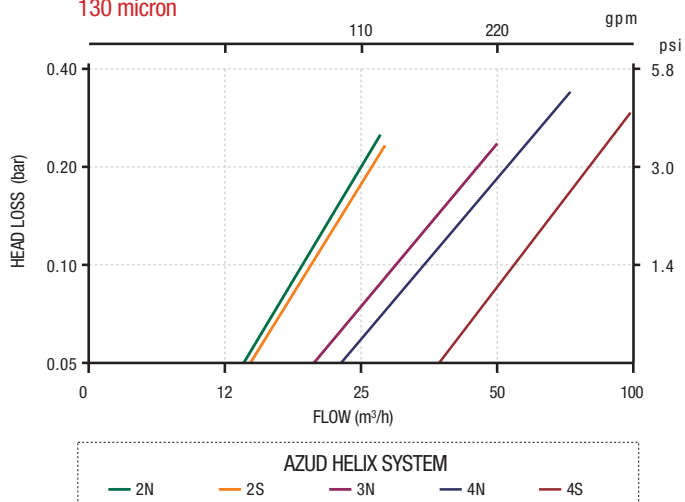

FILTER CONFIGURATION	Connection	Model	Connection			Dimensions					
			A	B	C	H		W		X	
						mm	in	mm	in	mm	in
	2"	2NR 2NA 2NV 2NW	BSP NPT GROOVED GROOVED	BSP NPT GROOVED BSP	BSP NPT BSP GROOVED	595	23.4	310	12.2	133	5.2
	2"Super	2SR 2SA 2SV 2SW	BSP NPT GROOVED GROOVED	BSP NPT GROOVED BSP	BSP NPT BSP GROOVED	720	28.3	310	12.2	133	5.2
	3"	3NR 3NA 3NV 3NW	BSP NPT GROOVED GROOVED	BSP NPT GROOVED BSP	BSP NPT BSP GROOVED	735	28.9	336	13.2	147	5.8
	4"	4NL 4NB	GROOVED FLANGE	GROOVED FLANGE	-	950	37.4	341	13.4	-	-
	4"Super	4SL 4SB	GROOVED FLANGE	GROOVED FLANGE	-	1200	47.2	341	13.4	-	-

Connection E 3/4" BSP • Connection M 1/4" BSP