

# SPECIFICATION

OF

## LIQUID CRYSTAL DISPLAY MODULE

CUSTOMER : AventModel No. : UMSH-8065MD-11TModel version : 6Document Revision : 7

### CUSTOMER APPROVED SIGNATURE

CUSTOMER APPROVED SIGNATURE			

This specification need to be signed by purchaser or customer as a specification of products production and delivery from URT. Without signature of this specification , any purchase order for this model no. will be treated and considered that this specification is automatically acknowledged and accepted by purchaser or customer.

 **U.R.T.**  **UNITED RADIANT TECHNOLOGY CORPORATION**

Joe Wu  
APPROVED

Ashin Chiu  
CHECKED

Jenny Wang  
PREPARED

Apr-28-2022  
Date

COMPANY : No. 2,Fu-hsing Road,Taichung Tanzi Technology Industrial Park,Tantzu,Taichung,Taiwan,R.O.C.

TEL: 886-4-25314277

FAX: 886-4-25313067

## Revision record

Document Revision	Model No. Version No.	Description	Revision by
0	UMSH-8065MD-T Version No. 0		Tony Chan Jeffry Chen 18-Jul-2007
1	UMSH-8065MD-11T Version No. 0	1.Modify the module number from UMSH-8065MD-T to UMSH-8065MD11T. 2.Modify the LED backlight to high brightness(500cd/ m <sup>2</sup> ).	H.C. Lin Jeffry Chen 11-Jan-2008
2	UMSH-8065MD-11T Version No. 1	1. Modify the specification of DC Characteristics. 2. Modify the description of interface pin. 3. Modify the Back-light only Specification	H.C. Lin Jeffry Chen 25-Mar-2008
3	UMSH-8065MD-11T Version No. 2	1. Modify the specification of AC Characteristics. 2. Modify the description of interface pin.	H.C. Lin Jeffry Chen 27-Feb-2009
4	UMSH-8065MD-11T Version No. 3	Revise the Back-light only Specification.	H.C. Lin Jeffry Chen 16-Aug-2011
5	UMSH-8065MD-11T Version No. 4	Revise the Note.	William Don Naoki Tsai 26-Nov-2014
6	UMSH-8065MD-11T Version No. 5	Modify the packing mode.	Design Section 29-Nov-2018
7	UMSH-8065MD-11T Version No. 6	Change the LCD Driver IC to HX8238-D.	William Don Eric Wang 28-Apr-2022
			Revision 7 ; UMSH-8065MD-11T Ver. 6 ; April-28-2022
			<b>Page: 2</b>

**CONTENTS:**

No.	Item	Page
1	<b>BASIC SPECIFICATION</b>	
	1.1 Mechanical Specification	4
	1.2 Display Specification	4
	1.3 Outline Dimension	5
	1.4 Block Diagram	6
	1.5 Interface Pin Connection	7~9
2	<b>ELECTRICAL CHARACTERISTICS</b>	
	2.1 Absolute Maximum Ratings	10
	2.2 DC Characteristics	11
	2.3 Back-light only Specification	12
	2.4 AC Characteristics	13~25
3	<b>OPTICAL CHARACTERISTICS</b>	
	3.1 Condition	26
	3.2 Definition of Optical Characteristics	27~28
4	<b>RELIABILITY</b>	29
5	<b>PRODUCT HANDING AND APPLICATION</b>	30
6	<b>DATECODE</b>	31
7	<b>LOT NO &amp; PACKING</b>	32~33
8	<b>INSPECTION STANDARD</b>	34~37

## 1. BASIC SPECIFICATION

### 1.1 Mechanical specifications

Items	Nominal Dimension	Unit
Active screen size	3.5" diagonal	-
Dot Matrix	320*RGB*240	dots
Module Size (W x H x T)	76.9 x 63.9 x 3.2	mm.
Active Area (W x H)	70.08 x 52.56	mm.
Dot Pitch (W x H)	0.219 x 0.219	mm.
Color depth	262K	color
Interface	8-bits serial/24-bits parallel RGB / CCIR601/656	-
Driving IC Package	COG	-

\* The maximum color depth of this driver IC is 262K colors ,not 16.7M.

### 1.2 Display specification

Display	Descriptions	Note
LCD Type	a-Si TFT	-
LCD Mode	TN/Normally White	-
Polarizer Mode	Transmissive	-
Polarizer Surface	Normal	-
Pixel arrangement	RGB-stripe	-
Backlight Type	LED	-
Viewing Direction(Gray inversion)	6 O'clock Direction	-

### 1.3 Outline dimension

CONFIDENTIAL(B)

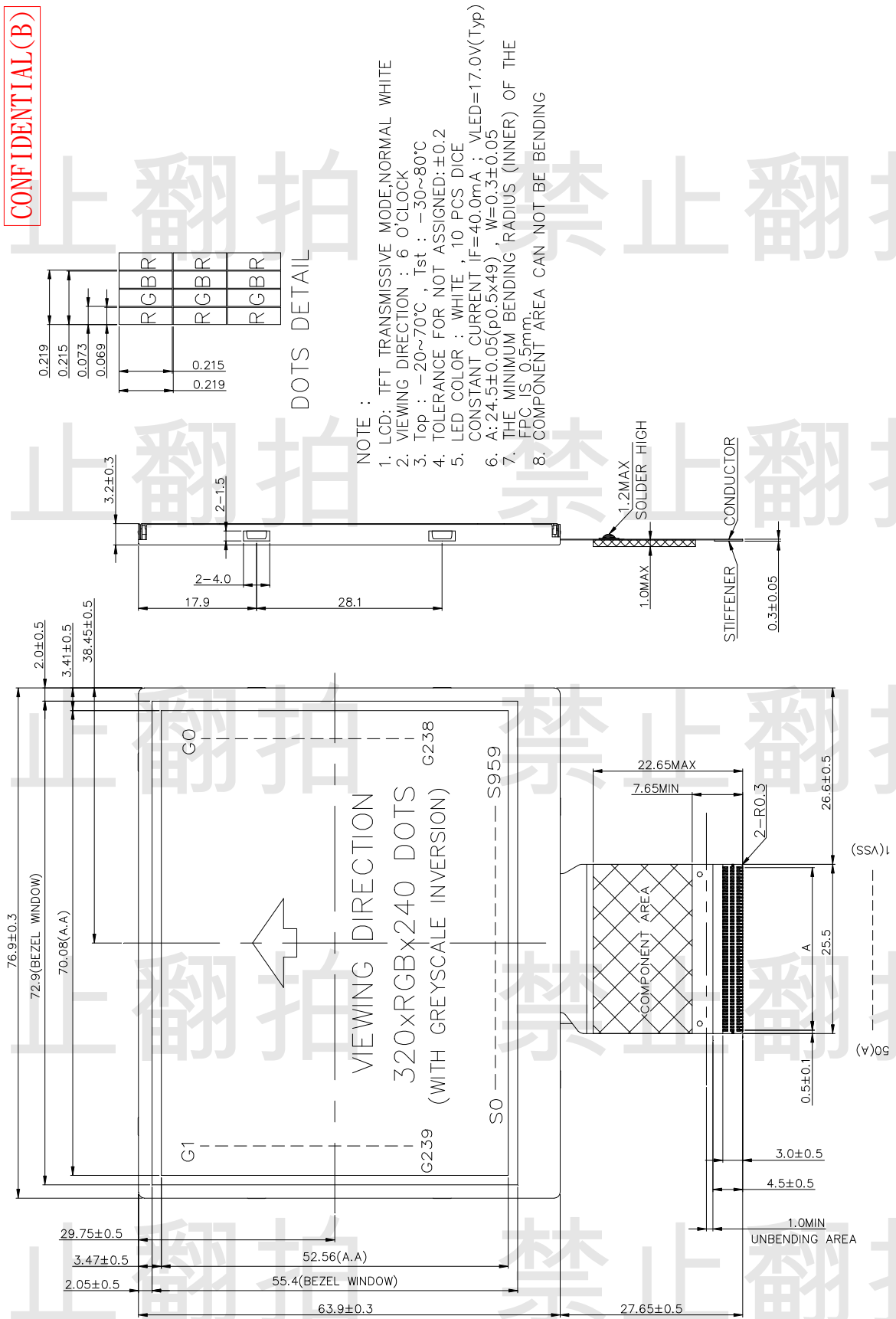

**1.4 Block diagram:**

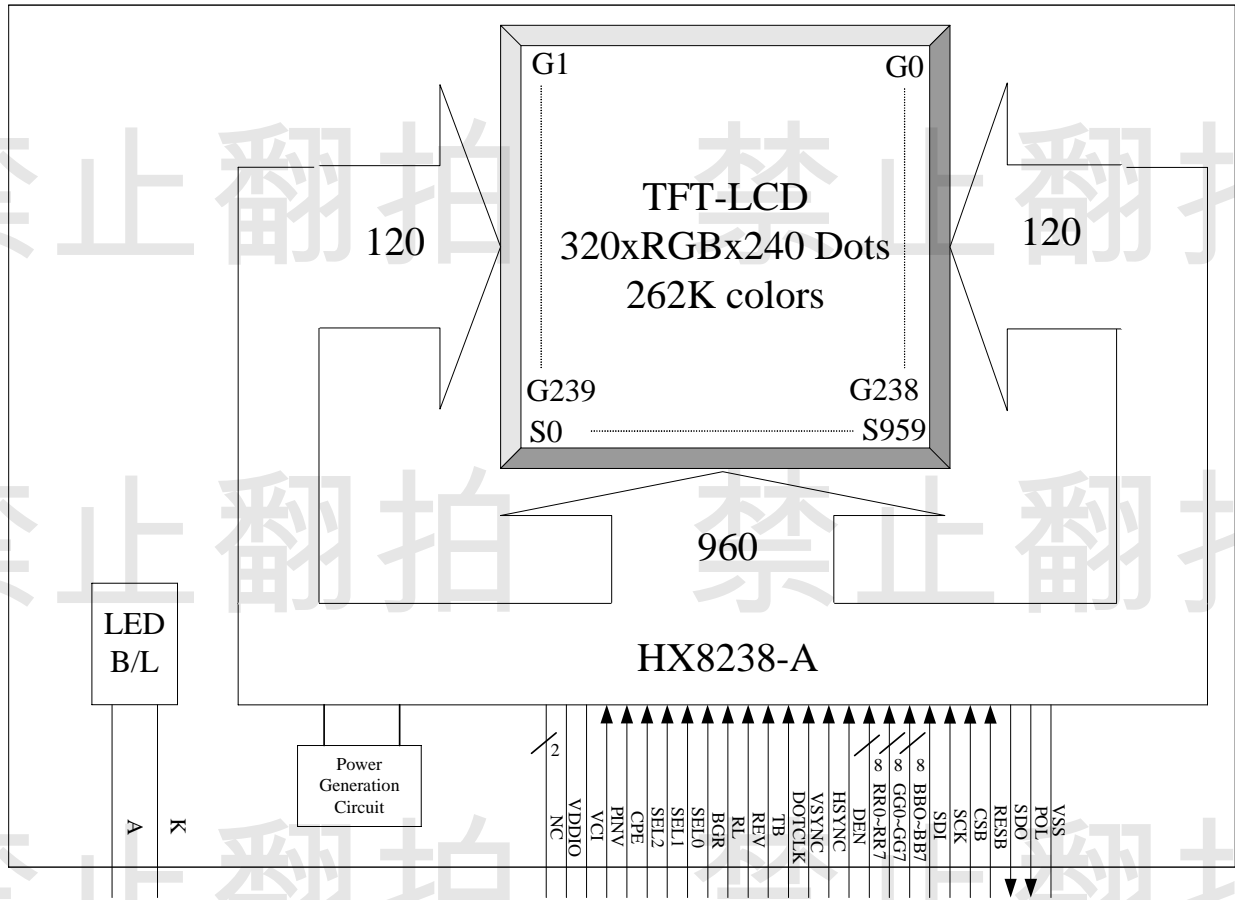

### 1.5 Interface Pin Connection:

Pin No.	Pin Name	I/O	Description
1	VSS	P	System ground pin of the IC. - Connect to system ground
2	POL	O	Polarity signal to monitor VCOM signal. - Leave it OPEN when not used
3	SDO	O	Data output pin in serial mode. - Leave it OPEN when not used
4	RESB	I	System reset pin. Internal pull high.
5	CSB	I	Chip select pin of serial interface. Internal pull high. - Leave it OPEN when not used.
6	SCK	I	Clock pin of serial interface. Internal pull high. - Leave it OPEN when not used
7	SDI	I	Data input pin in serial mode. Internal pull high. - Leave it OPEN when not used
8~31	BB [0:7] GG [0:7] RR [0:7]	I	Graphic Data Input Pins. Internal pull low. - RR [0:7]: Red Data - 8-bits - GG [0:7]: Green Data - 8-bits - BB [0:7]: Blue Data - 8-bits For 8 bit interface, only RR[0:7] are used. For unused pins, please connect to VSS or floating.
32	DEN	I	Display enable pin from controller. Connect to VDDIO or floating if not used.
33	HSYNC	I	Line synchronization signal. Internal pull high. - Fixed to VDDIO or floating if not used
34	VSYNC	I	Frame synchronization signal. Internal pull high. - Fixed to VDDIO or floating if not used.
35	DOTCLK	I	Dot-clock signal and oscillator source.

Pin No.	Pin Name	I/O	Description																																													
36	TB	I	Input pin to select the Gate driver scan direction. - Connect to VSS for Gate scan from G239 to G0 (reverse scan) - Connect to VDDIO for Gate scan from G0 to G239 (normal scan)																																													
37	REV	I	Input pin to select the display reversion. - Connect to VDDIO mapping data '0' to maximum pixel voltage for normally white panel - Connect to VSS for mapping data '0' to minimum pixel voltage for normally black panel																																													
38	RL	I	Input pin to select the Source driver data shift direction. - Connect to VDDIO for display first RGB data at S0-S2. - Connect to VSS for display first RGB data at S959-S957.																																													
39	BGR	I	Input pin to select the color mapping. - Connect to VDDIO for Blue-Green-Red mapping. - Connect to VSS for Red-Green-Blue mapping.																																													
40~42	SEL0~2	I	Input pin to select input interface mode.																																													
			<table border="1"> <thead> <tr> <th>SEL2</th> <th>SEL1</th> <th>SEL0</th> <th>Format</th> <th>Operating Frequency</th> </tr> </thead> <tbody> <tr> <td>0</td> <td>0</td> <td>0</td> <td>Parallel-RGB data format (only support stripe type color filter)</td> <td>7.5MHz</td> </tr> <tr> <td>0</td> <td>0</td> <td>1</td> <td>Serial-RGB data format</td> <td>19.5MHz</td> </tr> <tr> <td>0</td> <td>1</td> <td>0</td> <td>CCIR 656 data format (640RGB)</td> <td>24.54MHz</td> </tr> <tr> <td>0</td> <td>1</td> <td>1</td> <td>CCIR 656 data format (720RGB)</td> <td>27MHz</td> </tr> <tr> <td>1</td> <td>0</td> <td>0</td> <td>YUV mode A data format (Cr-Y-Cb-Y)</td> <td>24.54MHz</td> </tr> <tr> <td>1</td> <td>0</td> <td>1</td> <td>YUV mode A data format (Cr-Y-Cb-Y)</td> <td>27MHz</td> </tr> <tr> <td>1</td> <td>1</td> <td>0</td> <td>YUV mode B data format (Cb-Y-Cr-Y)</td> <td>27MHz</td> </tr> <tr> <td>1</td> <td>1</td> <td>1</td> <td>YUV mode B data format (Cb-Y-Cr-Y)</td> <td>24.54MHz</td> </tr> </tbody> </table>	SEL2	SEL1	SEL0	Format	Operating Frequency	0	0	0	Parallel-RGB data format (only support stripe type color filter)	7.5MHz	0	0	1	Serial-RGB data format	19.5MHz	0	1	0	CCIR 656 data format (640RGB)	24.54MHz	0	1	1	CCIR 656 data format (720RGB)	27MHz	1	0	0	YUV mode A data format (Cr-Y-Cb-Y)	24.54MHz	1	0	1	YUV mode A data format (Cr-Y-Cb-Y)	27MHz	1	1	0	YUV mode B data format (Cb-Y-Cr-Y)	27MHz	1	1	1	YUV mode B data format (Cb-Y-Cr-Y)	24.54MHz
			SEL2	SEL1	SEL0	Format	Operating Frequency																																									
			0	0	0	Parallel-RGB data format (only support stripe type color filter)	7.5MHz																																									
			0	0	1	Serial-RGB data format	19.5MHz																																									
			0	1	0	CCIR 656 data format (640RGB)	24.54MHz																																									
			0	1	1	CCIR 656 data format (720RGB)	27MHz																																									
			1	0	0	YUV mode A data format (Cr-Y-Cb-Y)	24.54MHz																																									
			1	0	1	YUV mode A data format (Cr-Y-Cb-Y)	27MHz																																									
1	1	0	YUV mode B data format (Cb-Y-Cr-Y)	27MHz																																												
1	1	1	YUV mode B data format (Cb-Y-Cr-Y)	24.54MHz																																												



Pin No.	Pin Name	I/O	Description
43	CPE	I	Input pin to enable internal charge pump circuit. Internal pull high. - Connect to VDDIO to enable internal charge pump. - Connect to VSS to disable internal charge pump
44	PINV	I	Control the polarity of POL signal. Internal pull low. - Connect to VDDIO, POL phase is reversed with internal VCOM signal. - Connect to VSS, POL phase is same with internal VCOM signal.
45	VCI	P	Power Supply for Analog Circuits.
46	VDDIO	P	Voltage input pin for I/O logic.
47	NC	-	No connection.
48	NC	-	No connection.
49	K	P	Backlight LED's cathode.
50	A	P	Backlight LED's anode.

## 2. ELECTRICAL CHARACTERISTICS

### 2.1 Absolute Maximum Ratings

Items	Symbol	Min.	Max.	Unit
Input voltage	VCI	VSS-0.3	5.0	V
Supply Voltage	VDDIO	VSS-0.3	4.0	V
Operate temperature range	TOP	-20	70	°C
Storage temperature range	TST	-30	80	°C

## 2.2 DC Characteristics

Items	Symbol	Min.	Typ.	Max.	Unit	Condition
Power supply voltage	VCI	2.5	3.3	3.6	V	
Power supply pin of IO pins	VDDIO	1.4	3.3	3.6	V	
Current consumption	I <sub>VCI+VDDIO</sub>	-	-	16	mA	NOTE
Dot Clock	DCK	-	7.5	10	MHz	
Serial Clock	XSCK	-	19.5	30	MHz	

NOTE : The method to illuminate the LCD panel is using the 2-4 7command under the measuring condition.

Measuring Condition :

Standard Value MAX.

Ta = 25°C

V<sub>CI</sub> = 3.3V

VDDIO = 3.3V

Dot Clock = 7.5MHz

Display Patten

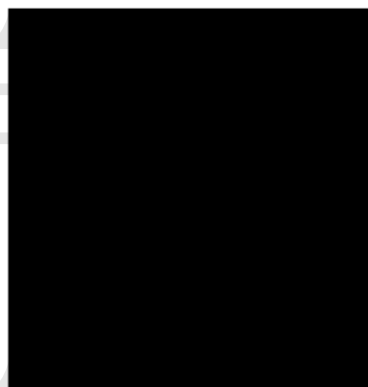

0 gray black pattern

### 2.3 Back-light only Specification:

Parameter	Symbol	Min	Typ	Max	Unit	Test Condition	Note
Supply Current	If	-	40	-	mA	Ta=25°C	-
Supply Voltage	VF	-	17	-	V	Ta=25°C	-
Half-Life Time	Lf	-	50000	-	hrs	-	1

Note1: The " Half-Life Time" is defined as the LED chip brightness decreases to 50% than original brightness, Based on Ta 25±2°C ,60±10% RH condition .

## 2.4 AC Characteristics

### 2.4.1 8-bits serial/24-bits parallel RGB

#### AC Characteristics

(Unless otherwise specified, Voltage Referenced to V<sub>SS</sub>,

T<sub>A</sub> = 25°C)

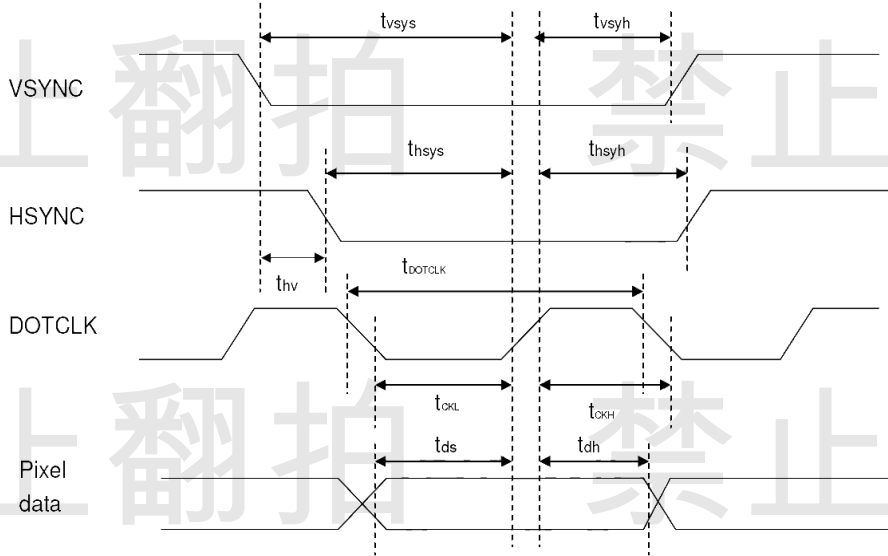
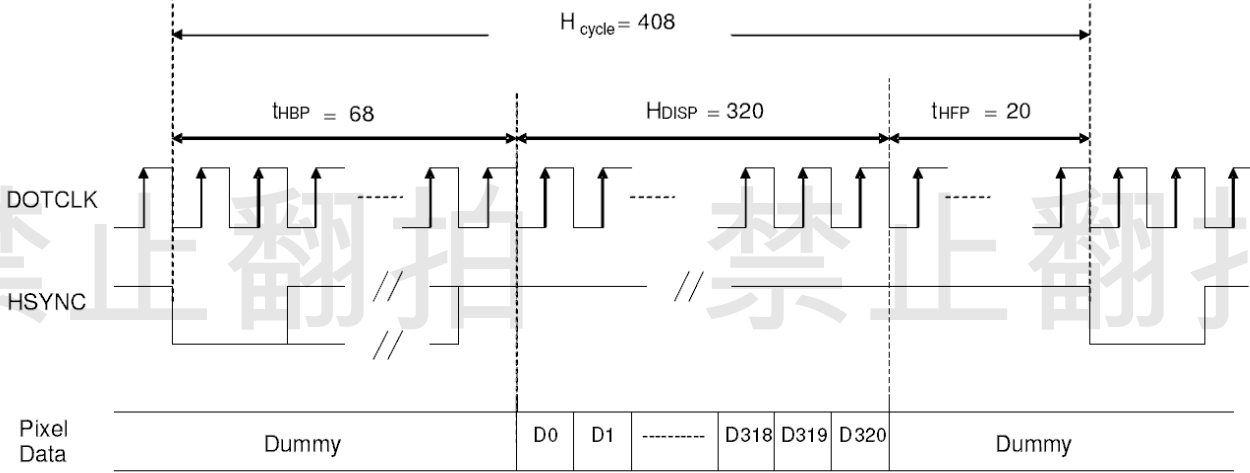

Figure 14. 1 Pixel Timing

Characteristics	Symbol	Min.		Typ.		Max.		Unit
		24bit	8bit	24bit	8bit	24bit	8bit	
DOTCLK Frequency	f <sub>DOTCLK</sub>	-		7.5	19.5	10	30	MHz
DOTCLK Period	t <sub>DOTCLK</sub>	100	33.3	133	51.3	-	-	ns
Vertical Sync Setup Time	t <sub>vsys</sub>	20	10	-	-	-	-	ns
Vertical Sync Hold Time	t <sub>vsyh</sub>	20	10	-	-	-	-	ns
Horizontal Sync Setup Time	t <sub>hsys</sub>	20	10	-	-	-	-	ns
Horizontal Sync Hold Time	t <sub>hsyh</sub>	20	10	-	-	-	-	ns
Phase difference of Sync Signal Falling Edge	t <sub>thv</sub>	1				240		t <sub>DOTCLK</sub>
DOTCLK Low Period	t <sub>tckl</sub>	50	15	-	-	-	-	ns
DOTCLK High Period	t <sub>tckh</sub>	50	15	-	-	-	-	ns
Data Setup Time	t <sub>tds</sub>	12	8	-	-	-	-	ns
Data hold Time	t <sub>tdh</sub>	12	8	-	-	-	-	ns
Reset pulse width	t <sub>RES</sub>	10						us

**Note:** External clock source must be provided to DOTCLK pin of HX8238-A. The driver will not operate if absent of the clocking signal.

Table 14. 1 Pixel Timing



a) Horizontal Data Transaction Timing

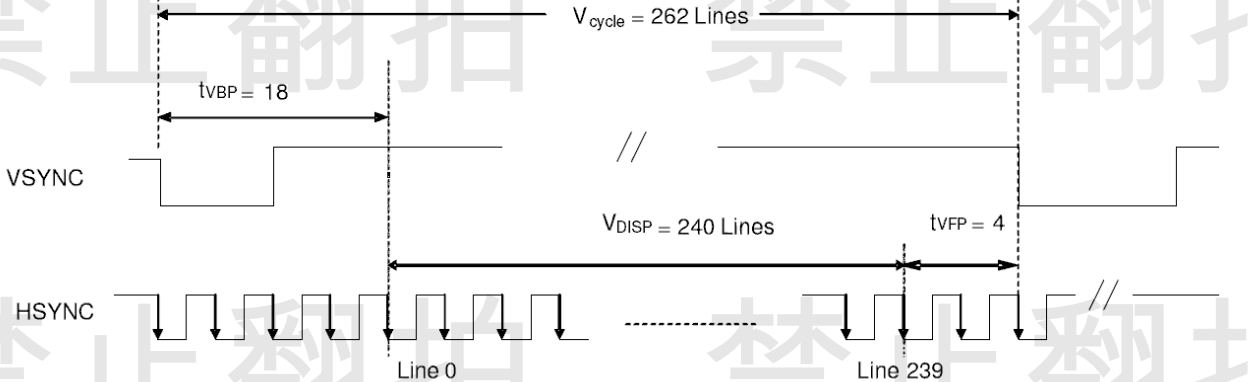

b) Vertical Data Transaction Timing

Figure 14. 2 Data transaction timing in parallel RGB (24 bit) interface (SYNC mode)

Characteristics	Symbol	Min		Typ		Max		Unit
		24bit	8 bit	24bit	8 bit	24bit	8 bit	
DOTCLK Frequency	fDOTCLK	-	-	7.5	19.5	10	30	MHz
DOTCLK Period	tDOTCLK	100	33.3	133	51.3	-	-	ns
Horizontal Frequency (Line)	fH	-		18.37		22.35		KHz
Vertical Frequency (Refresh)	fV	-		70		90		Hz
Horizontal Back Porch	tHBP	-	-	68	204	-	-	tDOTCLK
Horizontal Front Porch	tHFP	-	-	20	60	-	-	tDOTCLK
Horizontal Data Start Point	tHBP	-	-	68	204	-	-	tDOTCLK
Horizontal Blanking Period	tHBP + tHFP	-	-	88	264	-	-	tDOTCLK
Horizontal Display Area	HDISP	-	-	320	960	-	-	tDOTCLK
Horizontal Cycle	Hcycle	-	-	408	1224	450	1350	tDOTCLK
Vertical Back Porch	tVBP	-		18		-		Lines
Vertical Front Porch	tVFP	-		4		-		Lines
Vertical Data Start Point	tVBP	-		18		-		Lines
Vertical Blanking Period	tVBP + tVFP	-		22		-		Lines
Vertical Display Area	NTSC			240				Lines
	PAL			280(PALM=0)				
				288(PALM=1)				
Vertical Cycle	NTSC			262		350		Lines
	PAL			313				

Table 14. 2 Data Transaction Timing in Normal Operating Mode

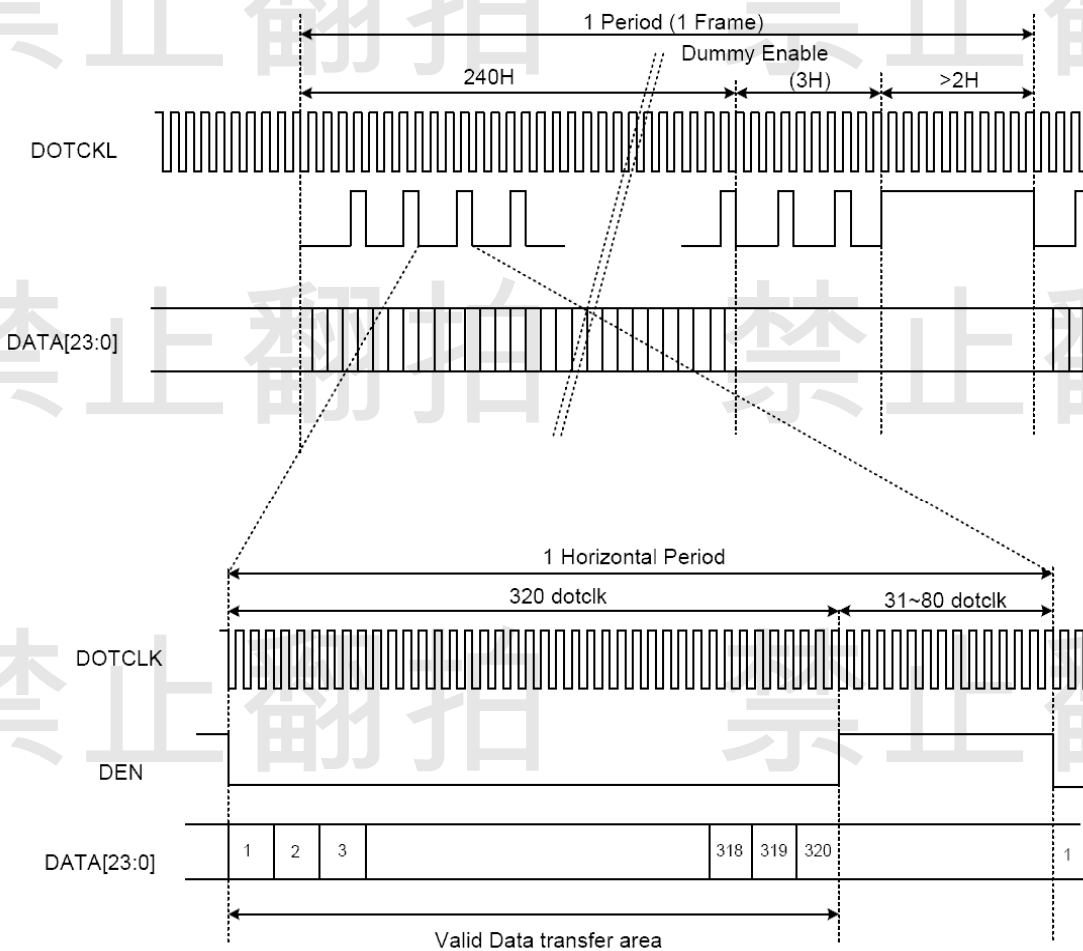
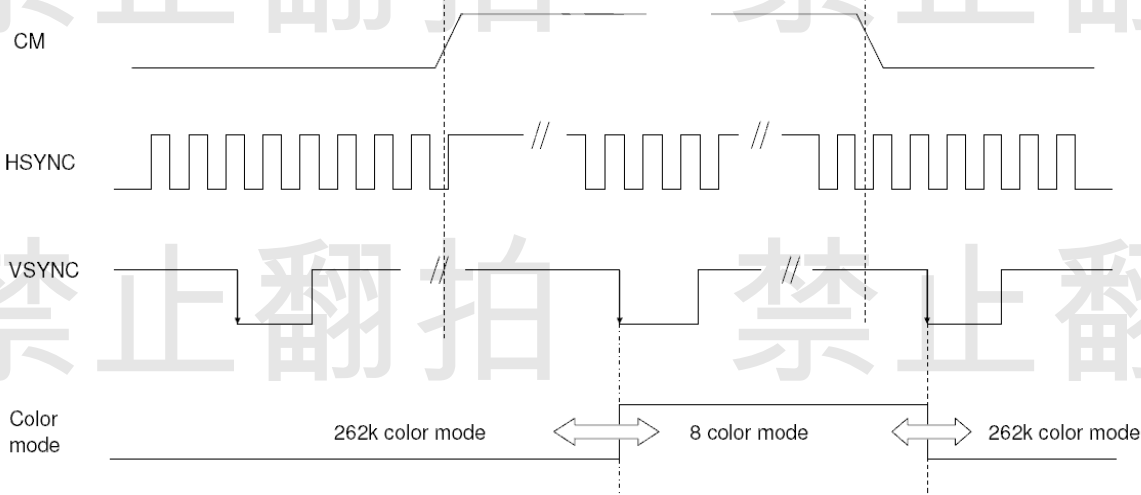

Figure 14. 3 Signal timing in DE mode



Note: The color mode conversion starts at the first falling edge of VSYNC after stage change of CM.

Figure 14. 4 Color mode conversion timing



## 2.4.2 CCIR601 Timing

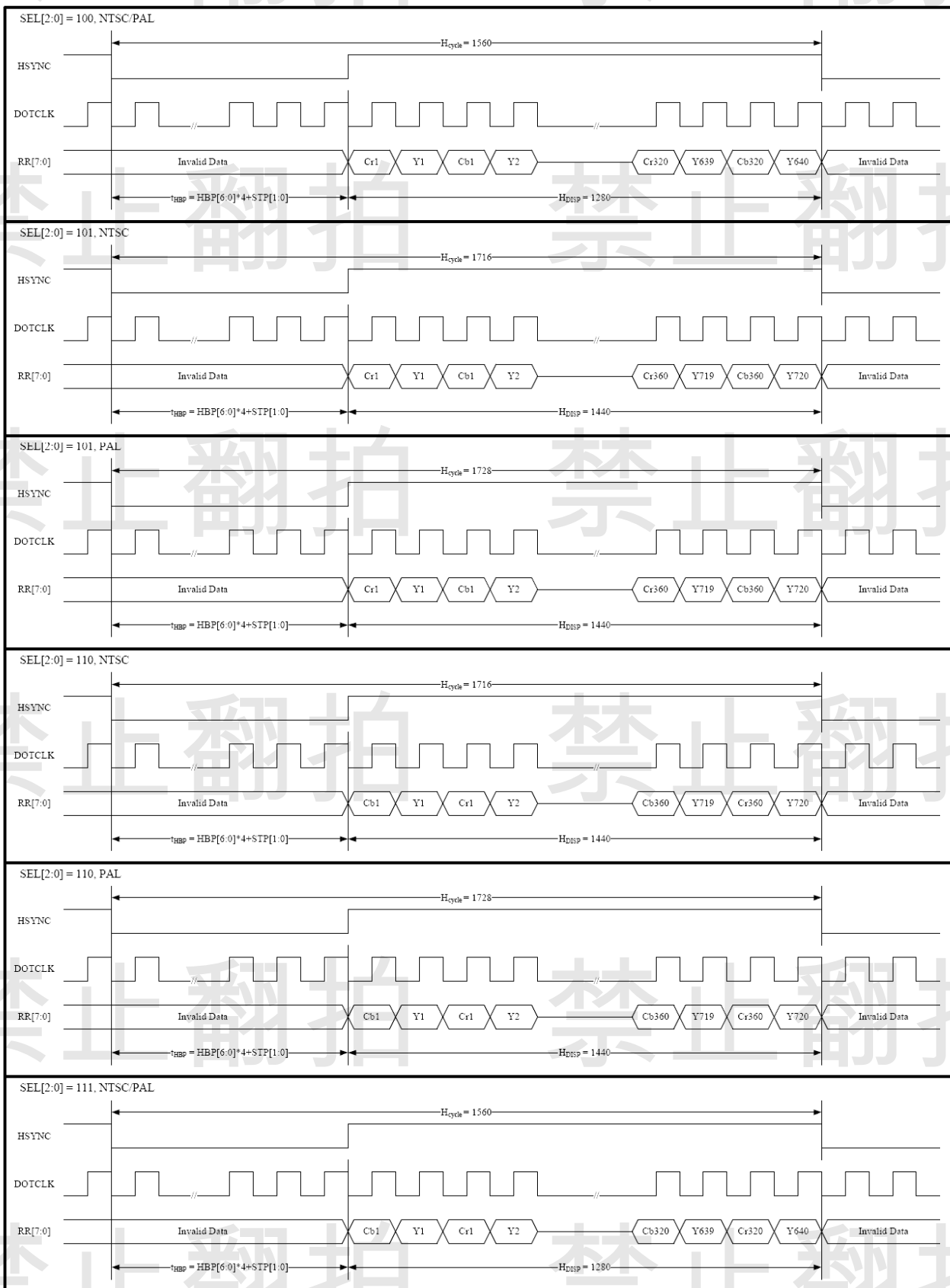

Figure 14. 5 CCIR601 horizontal timing

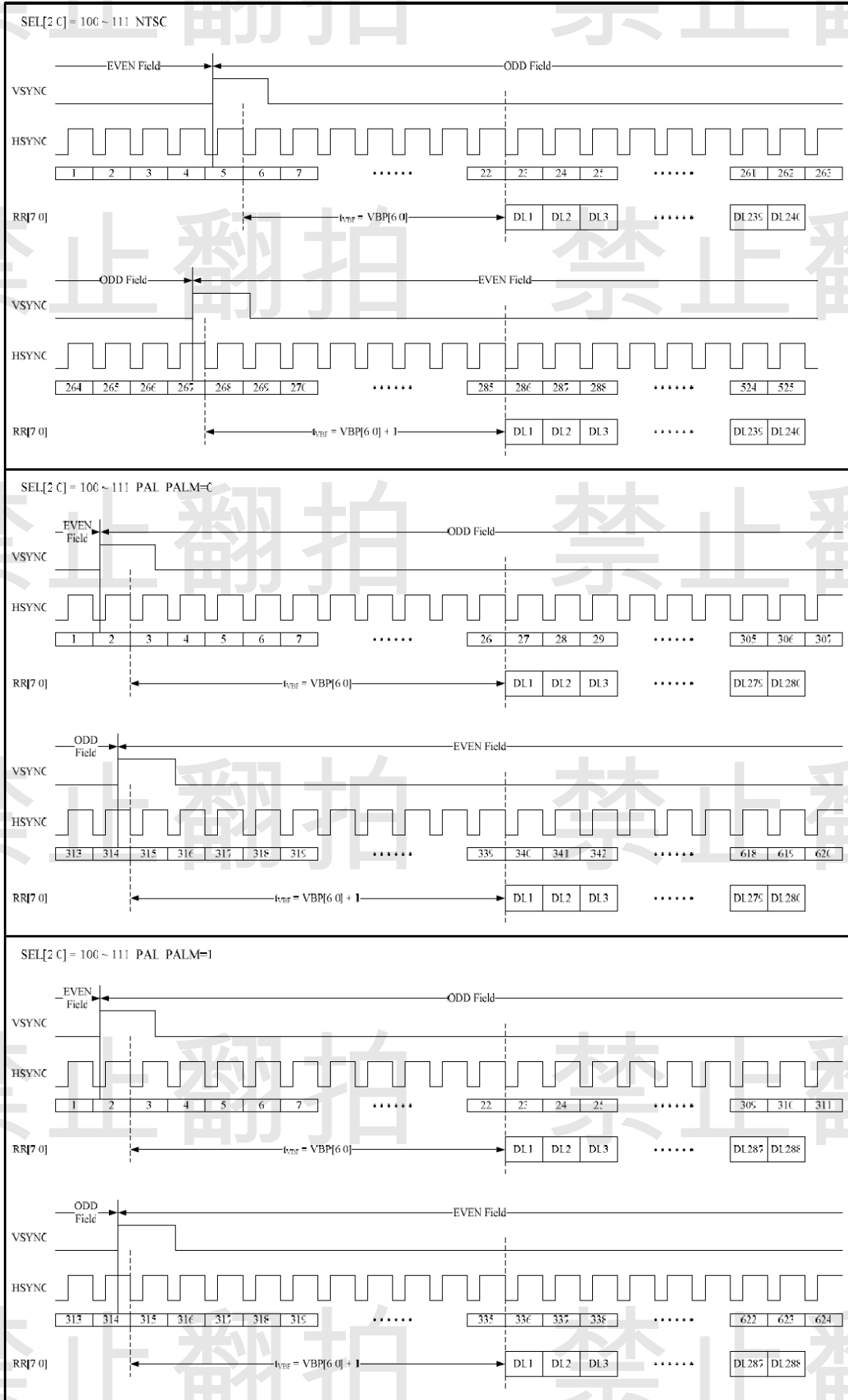

Figure 14. 6 CCIR601 vertical timing

## 2.4.3 CCIR656 Timing

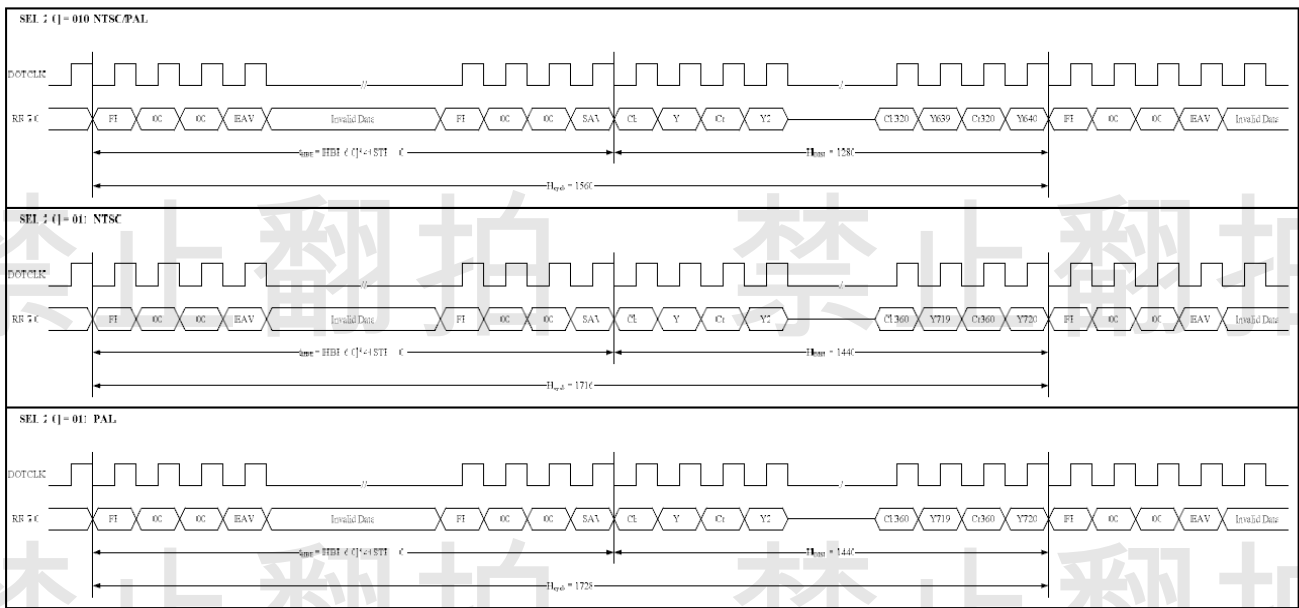

Figure 14. 7 CCIR656 horizontal timing

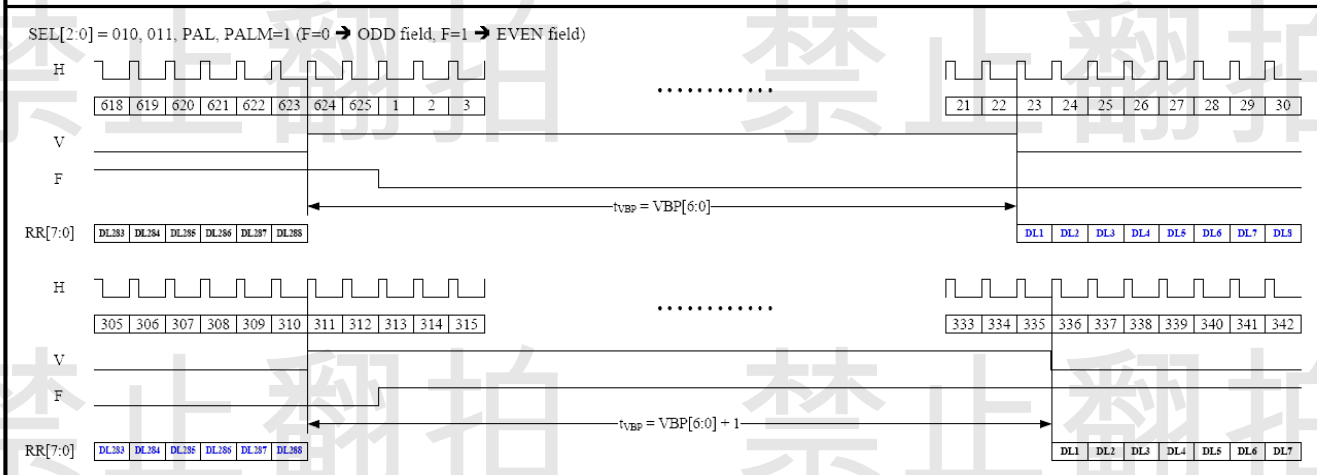
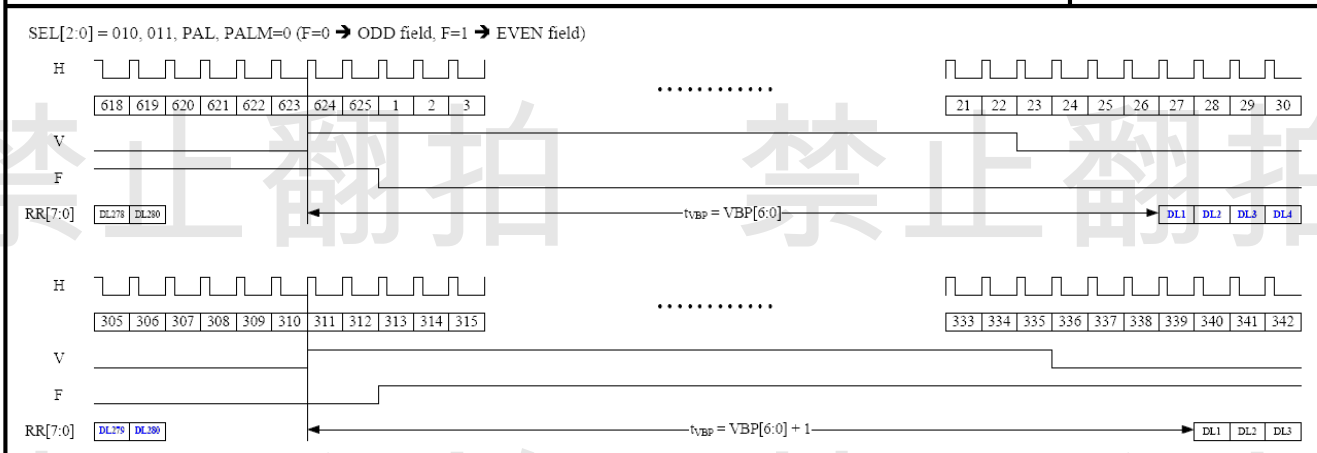
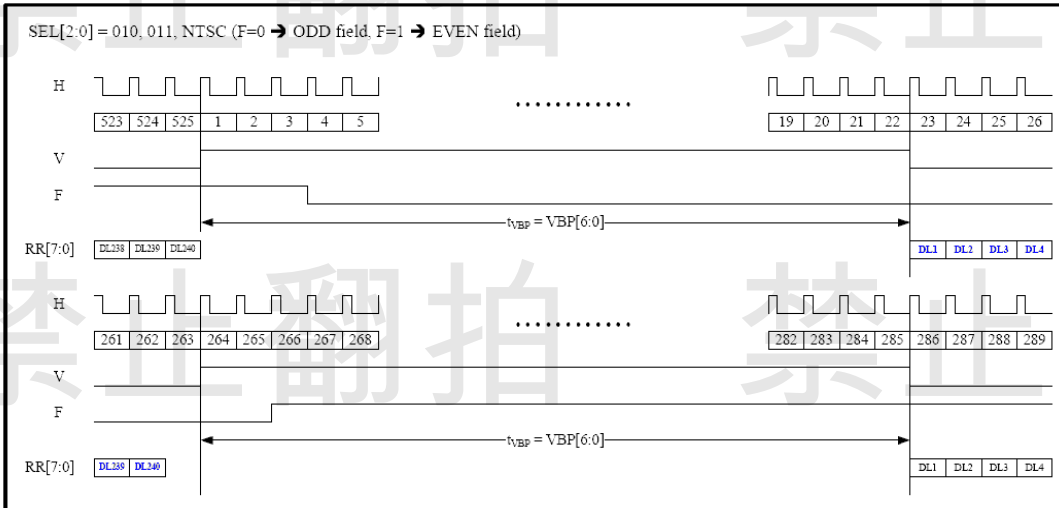
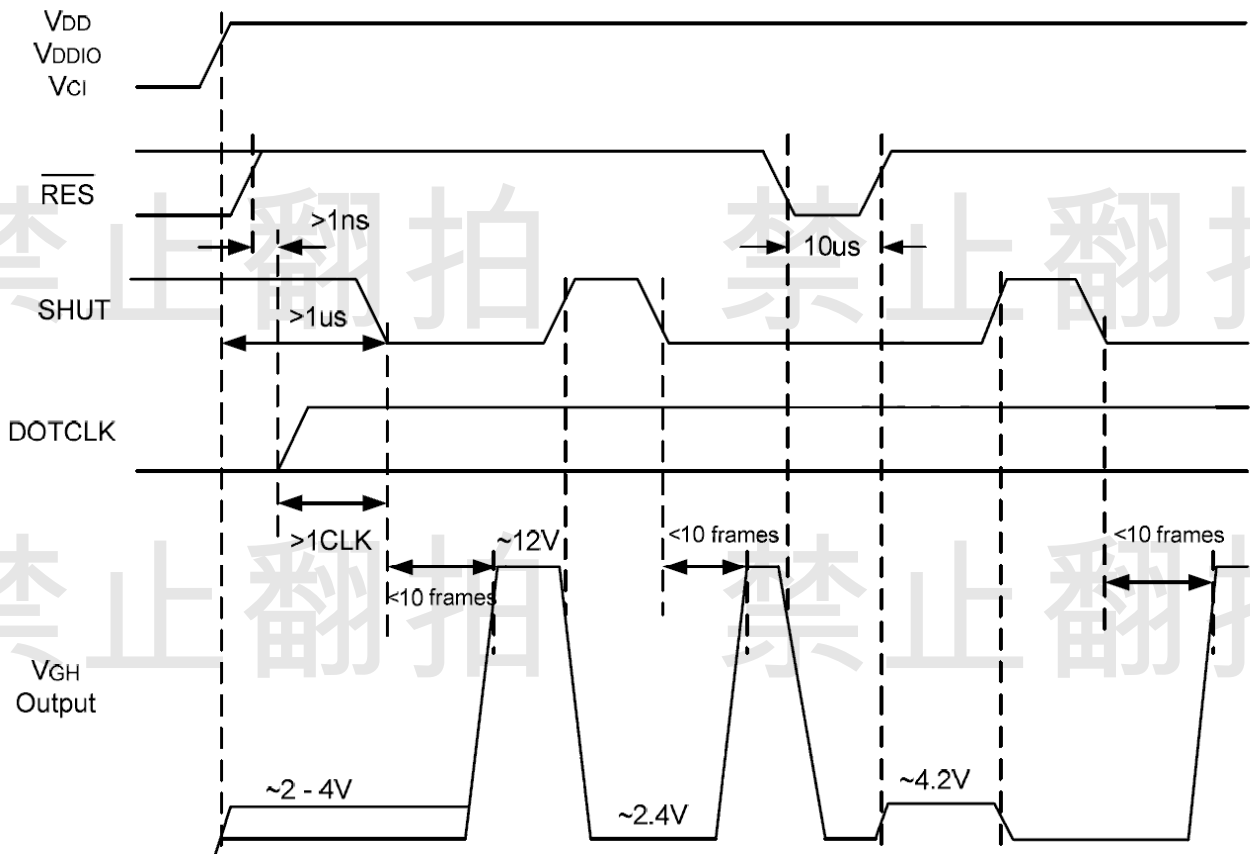

Figure 14. 8 CCIR656 vertical timing



**Figure 14. 9 VGH Output Against SHUT & RES**

- Note:**
- (1) The minimum cycle time of SHUT is  $10 + 2$  frames.
  - (2) DOTCLK must be provided for boosting of VGH. The above timing diagram assumed voltages and DOTCLK are continuous supplied after power on.
  - (3) VGH and VGL will be forced to VSS at the low stage of RESB.
  - (4) The minimum pulse width of RESB is  $10\mu\text{s}$ .

## 2.4.4 Power Up Sequence

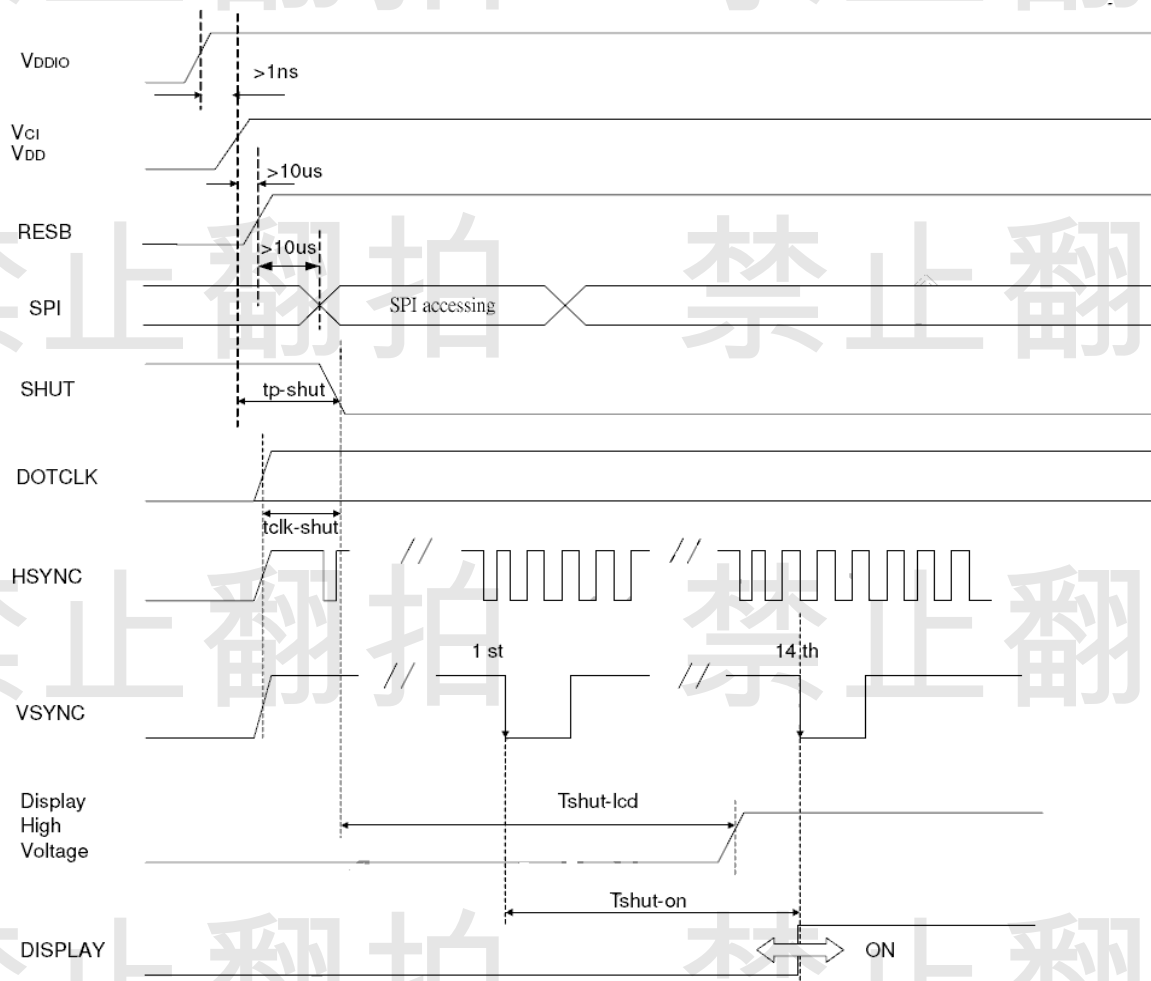

Figure 14. 10 Power Up Sequence

Characteristics	Symbol	Min	Typ	Max	Units
VDDD / VDDIO on to falling edge of SHUT	tp-shut	1	-	-	us
DOTCLK	tclk-shut	1	-	-	clk
Falling edge of SHUT to LCD power on	tshut-lcd	-	-	128	ms
Falling edge of SHUT to display start -1 line: 408 clk -1 frame: 262 line -DOTCLK = 7.5MHz	tshut-on	-	166	232.4	ms
				14	frame

**Note:** It is necessary to input DOTCLK before the falling edge of SHUT.

Display starts at 10th falling edge of VSTNC after the falling edge of SHUT.

Table 14. 3 Power Up Sequence

### 2.4.5 Power Down Sequence

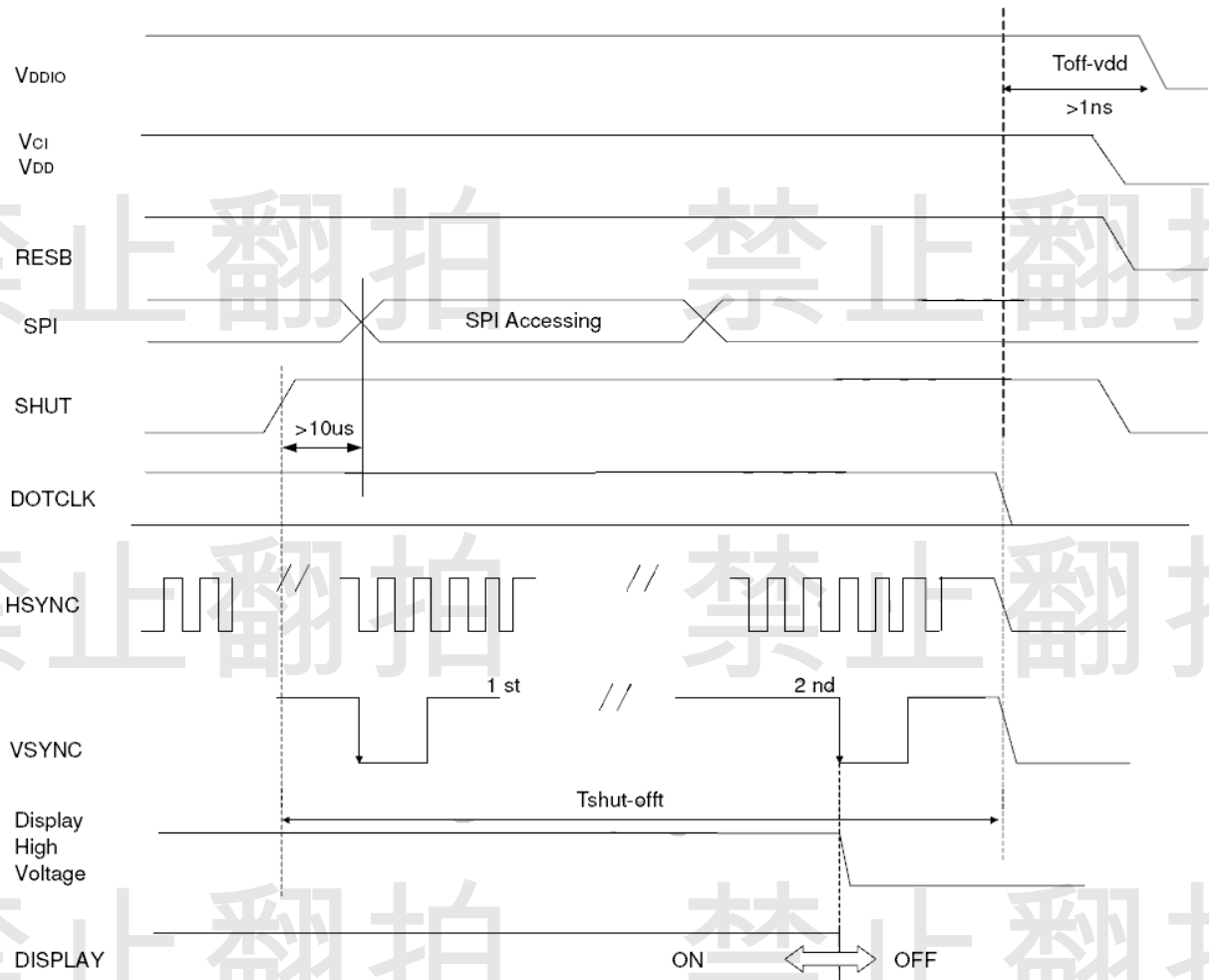

Figure 14. 11 Power Down Sequence

Characteristics	Symbol	Min	Typ	Max	Uni
Rising edge of SHUT to display off	tshut-off	2	-	-	frame
-1 line: 408 clk -1 frame: 262 line -DOTCLK = 7.5MHz		33.4	-	-	ms
Input-signal-off to VDDD / VDDIO off		1	-	-	us

**Note:** DOTCLK must be maintained at least 2 frames after the rising edge of SHUT.

Display become off at the 2nd falling edge of VSTNC after the falling edge of SHUT.

If RESET signal is necessary for power down, provide it after the 2-frames-cycle of the SHUT period.

Table 14. 4 Power Down Sequence

## 2.4.6 SPI Timing

First Transmission (Register)

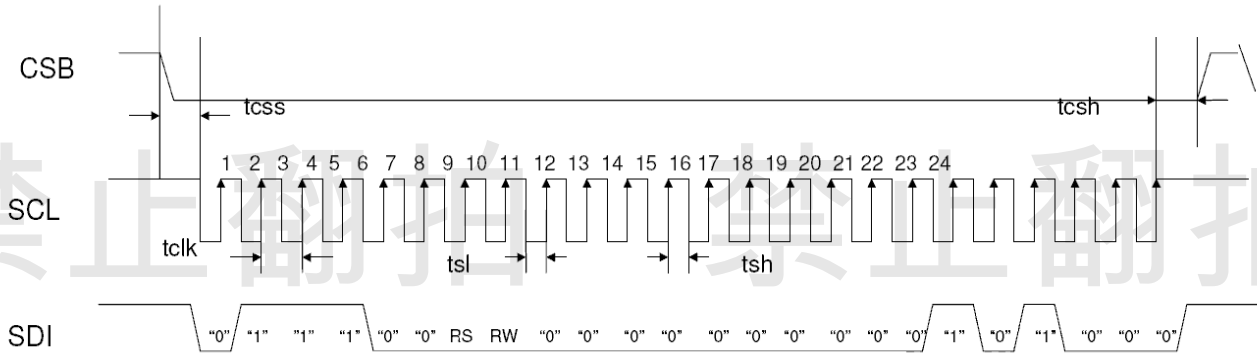

Second Transmission (Data)

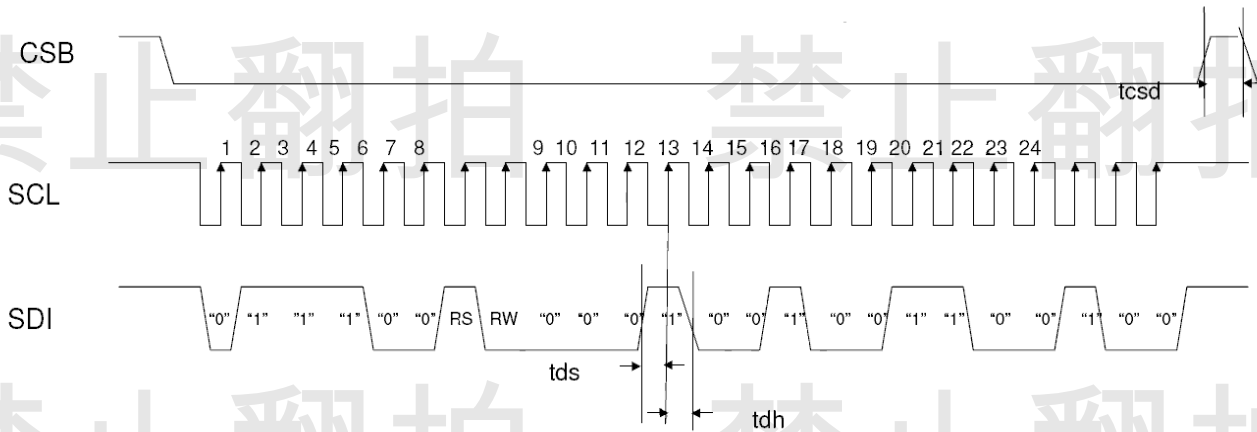

Note: The example transmit "0x1264h" to register R28h.  
SPID connected to VSS.

Figure 14. 12 SPI interface Timing Diagram & Transaction Example

Characteristics	Symbol	Min	Typ	Max	Unit
Serial Clock Frequency	fclk	-	-	20	MHz
Serial Clock Cycle Time	tclk	50	-	-	ns
Clock Low Width	tsl	25	-	-	ns
Clock High Width	tsh	25	-	-	ns
Chip Select Setup Time	tcss	0	-	-	ns
Chip Select Hold Time	tcsd	10	-	-	ns
Chip Select High Delay Time	tcsd	20	-	-	ns
Data Setup Time	tds	5	-	-	ns
Data Hold Time	tdh	10	-	-	ns

Table 14. 5 SPI Timing



## 2.4.7 Command ( Recommend by U.R.T. )

### LCD\_Initial\_HX-8238:

COMMAND	CODE	DESCRIPTION
R02H	0200	LCD-Driving-Waveform Control
R03H	6364	Power control 1
R04H	0440	Input Data and Color Filter Control
R0DH	3221	Power Control 2
R0EH	3100	Power Control 3

### Adjust the Gamma Curve:

COMMAND	CODE	DESCRIPTION
R30H	0000	Gamma Control 1
R31H	0407	Gamma Control 1
R32H	0202	Gamma Control 1
R33H	0000	Gamma Control 1
R34H	0505	Gamma Control 1
R36H	0707	Gamma Control 1
R37H	0000	Gamma Control 1
R3AH	0904	Gamma Control 2
R3BH	0904	Gamma Control 2

### 3. OPTICAL CHARACTERISTICS

#### 3.1 Characteristics

##### Electrical and Optical Characteristics

No.	Item		symbol / temp.	Min.	Typ.	Max.	Unit	Note	
1	Response Time		Tr	25	-	15	ms	2	
			Tf	25	-	35			50
2	Viewing Angle	Hor.	$\theta_{2+}$	$\Phi = 0^\circ$	60	80	-	degree	3
			$\theta_{2-}$	$\Phi = 180^\circ$	60	80	-		
		Ver.	$\theta_{1+}$	$\Phi = 270^\circ$	60	80	-		
			$\theta_{1-}$	$\Phi = 90^\circ$	30	45	-		
3	Contrast Ratio		Cr	25	400	800	-	4	
4	Red x-code		Rx	25	0.58	0.63	0.68	-	5
	Red y-code		Ry		0.31	0.36	0.41		
	Green x-code		Gx		0.29	0.34	0.39		
	Green y-code		Gy		0.54	0.59	0.64		
	Blue x-code		Bx		0.09	0.14	0.19		
	Blue y-code		By		0.05	0.10	0.15		
	White x-code		Wx		0.27	0.32	0.37		
	White y-code		Wy		0.30	0.35	0.40		
	Brightness		Y		500	700	-		
5	Brightness Uniformity			25	80	-	-	%	6

### 3.2 Definition of optical characteristics

Measurement condition :

Transmissive and Transflective type

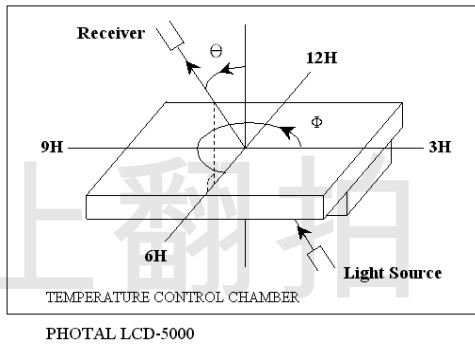

[Note 1] Definition of LCD Driving Vop and Waveform :

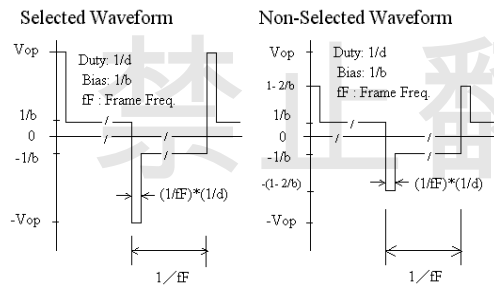
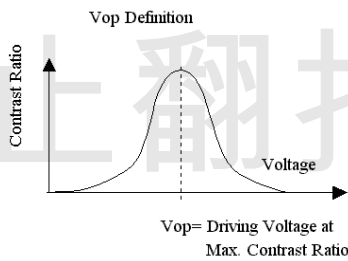

[Note 2] Definition of Response Time

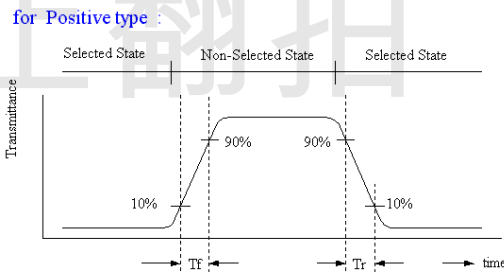

[Note 3] Definition of Viewing Angle :

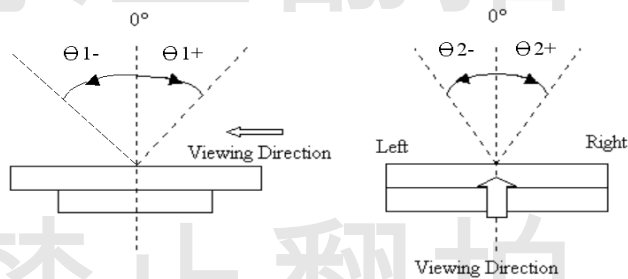

[Note 4] Definition of Contrast Ratio :

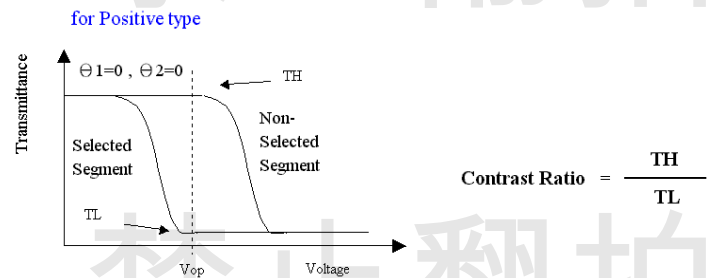

**[Note 5] Definition of measurement of Color Chromaticity and Brightness**

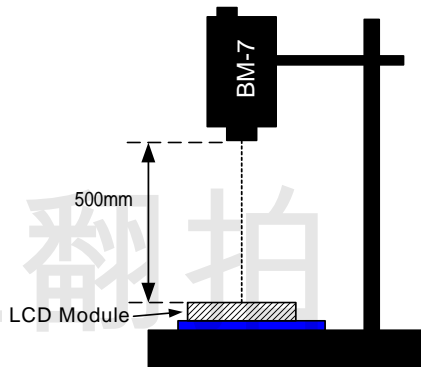

**[Note 6] Definition of Brightness Uniformity**

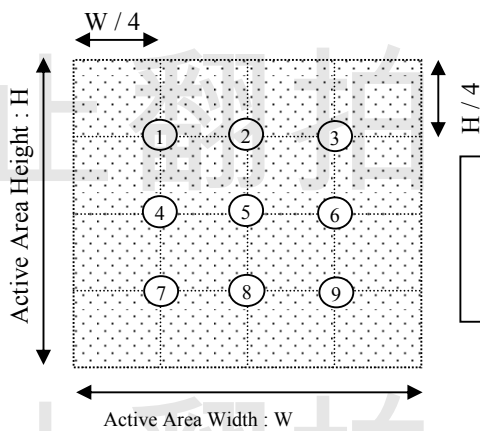

$$\text{Brightness Uniformity} = \frac{\text{Minimum Brightness of Point 1~9}}{\text{Maximum Brightness of Point 1~9}}$$

**[Note 7] Definition of Measurement of Reflectance**

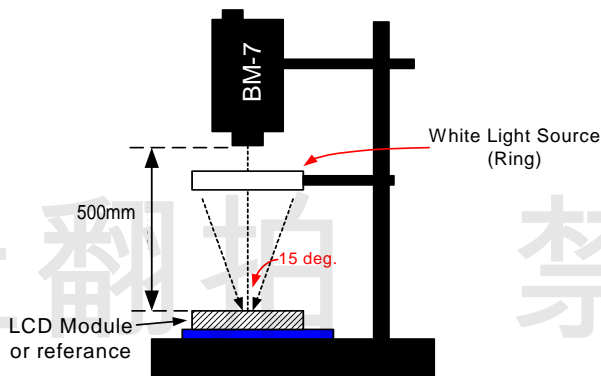

#### 4. RELIABILITY :

Item No	Items	Condition	Note
1	High temperature operating	70 , 200 hours	1
2	Low temperature operating	-20 , 200 hours	1
3	High temperature storage	80 , 200 hours	1
4	Low temperature storage	-30 , 200 hours	1
5	High temperature & humidity storage	60 , 90%RH, 100 hours	2
6	Thermal Shock storage	-30 , 30min.<=> 80 , 30min. 10 Cycles	1
7	Vibration test	10 => 55 =>10 => 55 => 10 Hz , within 1 minute Amplitude : 1.5mm. 15 minutes for each Direction ( X,Y,Z )	
8	Drop test	Packed, 100CM free fall, 6 sides, 1 corner, 3edges	
9	Life time	50,000 hours 25 , 60%RH , specification condition driving	

Note 1 : The product move into the room temperature for at least 2 hours with no condensation.

Note 2 : The product move into the room temperature for at least 24 hours with no condensation.

Note 3 : Please change the display picture (autorun) during operating mode. Avoid displaying static images to avoid image sticking , and the image sticking is accelerated by temperature.

\* One single product test for only one item.

\* Judgment after test : keep in room temperature for more than 2 hours.

- Current consumption < 2 times of initial value
- Contrast > 1/2 initial value
- Function : work normally

## 5. PRODUCT HANDLING AND APPLICATION

### PRECAUTION FOR HANDLING LCM

The LCD module contains a C-MOS LSI. People who operate the LCM should wear ESD protection equipment to prevent ESD hurt on products.

Do not input any signal before power is turned on.

Do not take LCM from its packaging bag until it is assembled.

Peel off the LCM protective film slowly since static electricity may be generated.

Pay attention to the humidity of the work shop, 50~60%RH is satisfactory.

Use a non-leak iron for soldering LCM.

Do not touch the display surface or connection terminals area with bare hands. Smudges on the display surface reduce the insulation between terminals.

Cautions for soldering to LCM:

Condition for soldering I/O terminals:

Temperature at iron tip :350 ±15 .

Soldering time : 3~4sec./ terminals.

Type of solder : Eutectic solder(rosin flux filled).

### PRECAUTION IN USE OF LCD

Do not contact or scratch the front surface and the contact pads of a LCD panel with hard materials such as metal or glass or with one's nail.

To clean the surface , wipe it gently with soft cloth dampened by alcohol.

Do not attempt to wiped off the contact pads.

Keep LCD panels away from direct sunlight , also avoid them in high-temperature & high humidity environment for a long period.

Do not drive LCD panels by DC voltage.

Do not expose LCD panels to organic solvent.

Liquid in LCD is hazardous substance. In case a contact with liquid crystal material is occurred, be sure to immediately wash such material away by soap and water.

The polarizer is easily damaged and should be handle with special care. Don't press or rub it with hard objects.

### PRECAUTION FOR STORING AND USE OF LCM

To avoid degradation of the device , do not store the module under the conditions of direct sunlight , high temperature or high humidity . Keep the module in bags designed to prevent static electricity charging under low temperature / normal humidity conditions(avoid high temperature / high humidity and low temperature below 0 )

Never use the LCD , LCM under 45 Hz , the liquid crystal will decomposition and cause permently damage on display !!

### USING ON MEDICAL CARE , SAFETY OR HAZARDOUS APPLICATION OR SYSTEM

For the application in medical care, safety and hazardous products or systems, an authorization from URT is required. URT will not responsible for any damage or loss which caused by the products without any authorization given by URT.

This product is not allowed to be designed and used for military application and/or purpose.

The delivery of this product to the countries and/or regions where the embargoes are imposed by U.N. is prohibited.

The application and delivery of this product must comply with Strategic High-Tech Commodities (SHTC) export control and the sales to the embargoed and/or sanctioned countries or regions are strictly prohibited.

## 6. DATE CODE OF PRODUCTS

Date code will be shown on each product :

**YY MM DD - XXXX**

Year Month Day - Serial no.

Example: 141108 - 0003 ==> Year 2014, November,8th ,Serial no.0003

Note : The lot no. attached on the packing box will be used for tracking once the part is too small to print the date code.

## 7. LOT NO & PACKING

Instruction of lot number:

LOT NO. : 0 0 0 8 3 5 2 5 (EX)

Date

01-1 st  
02-2 nd  
31-31 th

Week

1 — 7

Week of Month

1 — 5

Month

01-January  
02-February  
12-December

Year

00-2000  
01-2001

Label of carton:

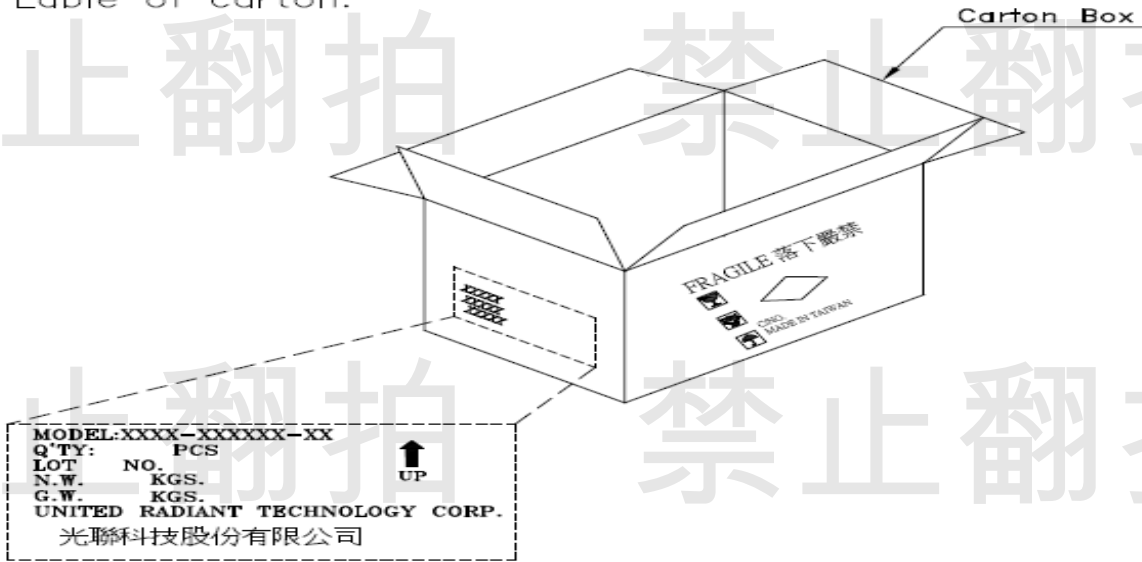

Packing tray must be stacked with alternated direction to each others.  
To tacks packing trays in same direction will cause product damaged.

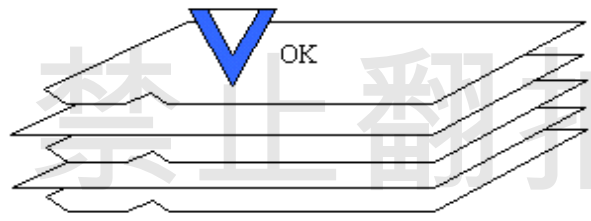
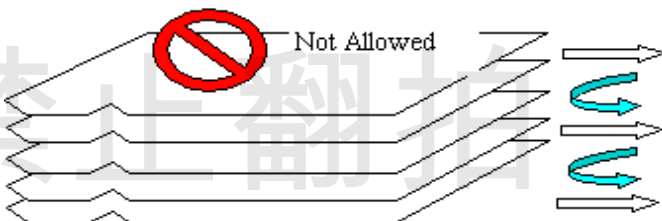
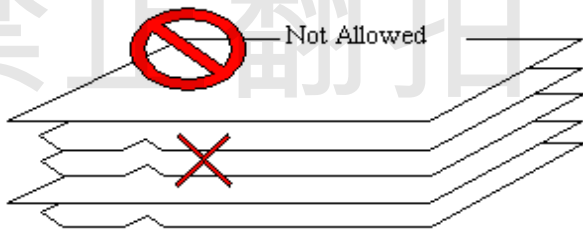



MODEL NO : UMSH-8065MD-11T

6 pcs / Tray

7+1 Tray / Box

4 Box / Carton

168 pcs / Carton

NOTE:

(1) Be warned, the direction of the tray has to turn it by 180 degree before stack it up. Otherwise, it will be packager's responsibility!!

(2) Safe Stack : 5 cartons only

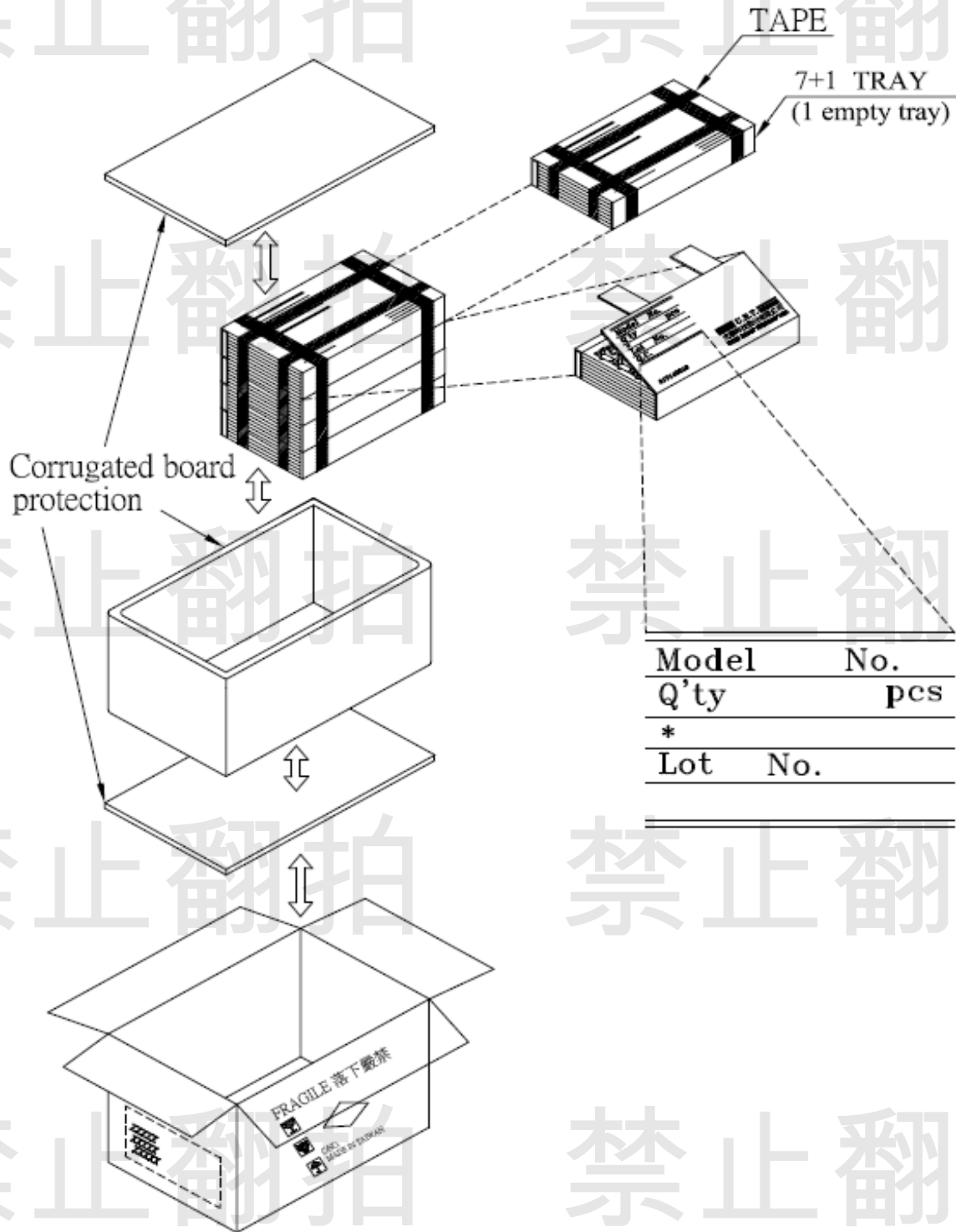

## 8. INSPECTION STANDARD

### 8.1. QUALITY :

THE QUALITY OF GOODS SUPPLIED TO PURCHASER SHALL COME UP TO THE FOLLOWING STANDARD.

#### 8.1.1. THE METHOD OF PRESERVING GOODS

AFTER DELIVERY OF GOODS FROM U.R.T. TO PURCHASER. PURCHASER SHALL CONTROL THE LCM AT -10 TO 40 ,AND IT MIGHT BE DESIRABLE TO KEEP AT THE NORMAL ROOM TEMPERATURE AND HUMIDITY UNTIL INCOMING INSPECTION OR THROWING INTO PROCESS LINE.

#### 8.1.2. INCOMING INSPECTION

##### (A) THE METHOD OF INSPECTION

IF PURCHASER MAKE AN INCOMING INSPECTION , A SAMPLING PLAN SHALL BE APPLIED ON THE CONDITION THAT QUALITY OF ONE DELIVERY SHALL BE REGARDED AS ONE LOT.

##### (B) THE STANDARD OF QUALITY

ISO-2859-1 ( or MIL-STD-105E ) , LEVEL SINGLE PLAN.

CLASS	AQL(%)
CRITICAL	0.4 %
MAJOR	0.65 %
MINOR	1.5 %

EVERY ITEM SHALL BE INSPECTED ACCORDING TO THE CLASS.

##### (C) MEASURE

IF AS THE RESULT OF ABOVE RECEIVING INSPECTION , A LOT OUT IS DISCOVERED. PURCHASER SHALL BE INFORM SELLER OF IT WITHIN SEVEN DAYS. BUT FIRST SHIPMENT WITHIN FOURTEEN DAYS.

#### 8.1.3. WARRANTY POLICY

U.R.T. WILL PROVIDE ONE-YEAR WARRANTY FOR THE PRODUCTS ONLY IF UNDER SPECIFICATION OPERATING CONDITIONS. U.R.T. WILL REPLACE NEW PRODUCTS FOR THESE DEFECT PRODUCT; WHICH UNDER WARRANTY PERIOD AND BELONG TO THE RESPONSIBILITY OF U.R.T.

### 8.2. CHECKING CONDITION

8.2.1. VIEWING DISTANCE IS APPROXIMATELY :  $30 \pm 5$  CM.

8.2.2. VIEWING ANGLE IS NORMAL TO THE LCD PANEL WITH  $45^\circ$ .

8.2.3. AMBIENT ILLUMINANCE : 2 PCS OF 20W FLUORESCENT LAMPS( DISTANCE TO THE SAMPLE  $>100$ CM)  
OR  $1000 \pm 200$  LUX.

### 8.3. INSPECTION PLAN :

CLASS	ITEM	JUDGEMENT	CLASS
PACKING & INDICATE	1. OUTSIDE AND INSIDE PACKAGE	"MODEL NO." , "LOT NO." AND "QUANTITY" SHOULD INDICATE ON THE PACKAGE.	Minor
	2. MODEL MIXED AND QUANTITY	OTHER MODEL MIXED.....REJECTED QUANTITY SHORT OR OVER.....REJECTED	Critical
	3. PRODUCT INDICATION	"MODEL NO." SHOULD INDICATE ON THE PRODUCT	Major
ASSEMBLY	4. DIMENSION, LCD GLASS SCRATCH AND SCRIBE DEFECT.	ACCORDING TO SPECIFICATION OR DRAWING.	Major
APPEARANCE	5. VIEWING AREA	POLARIZER EDGE OR LCD'S SEALING LINE IS VISABLE IN THE VIEWING AREA .....REJECTED	Minor
	6. BLEMISH, BLACK SPOT, WHITE SPOT IN THE LCD AND LCD GLASS CRACKS	ACCORDING TO STANDARD OF VISUAL INSPECTION ( INSIDE VIEWING AREA )	Minor
	7. BLEMISH, BLACK SPOT WHITE SPOT AND SCRATCH ON THE POLARIZER	ACCORDING TO STANDARD OF VISUAL INSPECTION ( INSIDE VIEWING AREA )	Minor
	8. BUBBLE IN POLARIZER	ACCORDING TO STANDARD OF VISUAL INSPECTION ( INSIDE VIEWING AREA )	Minor
	9. LCD'S RAINBOW COLOR	STRONG DEVIATION COLOR ( OR NEWTON RING) OF LCD.....REJECTED. OR ACCORDING TO LIMITED SAMPLE ( IF NEEDED, AND INSIDE VIEWING AREA )	Minor
ELECTRICAL	10. ELECTRICAL AND OPTICAL CHARACTERISTICS ( CONTRAST, VOP, CHROMATICITY ... ETC )	ACCORDING TO SPECIFICATION OR DRAWING . ( INSIDE VIEWING AREA )	Critical
	11.MISSING LINE	MISSING DOT, LINE, CHARACTER .....REJECTED	Critical
	12.SHORT CIRCUIT, WRONG PATTERN DISPLAY	NO DISPLAY, WRONG PATTERN DISPLAY, CURRENT CONSUMPTION OUT OF SPECIFICATION..... REJECTED	Critical
	13. DOT DEFECT (FOR COLOR AND TFT)	ACCORDING TO STANDARD OF VISUAL INSPECTION	Minor

### 8.4. STANDARD OF VISUAL INSPECTION

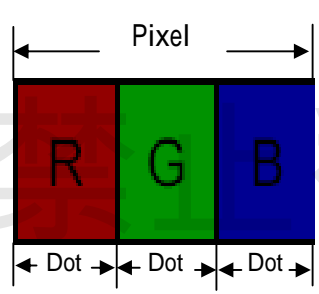
NO.	CLASS	ITEM	JUDGEMENT																				
8.4.1	MINOR	BLACK AND WHITE SPOT FOREIGN MATERIEL DUST IN THE CELL BLEMISH SCRATCH	<p>(A) ROUND TYPE: <span style="float: right;">unit : mm.</span></p> <table border="1"> <thead> <tr> <th>DIAMETER (mm.)</th> <th>ACCEPTABLE Q'TY</th> </tr> </thead> <tbody> <tr> <td>0.1</td> <td>DISREGARD</td> </tr> <tr> <td>0.1 &lt; 0.25</td> <td>3 (D&gt;5mm)</td> </tr> <tr> <td>0.25 &lt;</td> <td>0</td> </tr> </tbody> </table> <p>NOTE: <math>=(\text{LENGTH}+\text{WIDTH})/2</math></p> <p>(B) LINEAR TYPE: <span style="float: right;">unit : mm.</span></p> <table border="1"> <thead> <tr> <th>LENGTH</th> <th>WIDTH</th> <th>ACCEPTABLE Q'TY</th> </tr> </thead> <tbody> <tr> <td>-----</td> <td>W 0.03</td> <td>DISREGARD</td> </tr> <tr> <td>L 5.0</td> <td>0.03 &lt; W 0.07</td> <td>3 (D&gt;5mm)</td> </tr> <tr> <td>-----</td> <td>0.07 &lt; W</td> <td>FOLLOW ROUND TYPE</td> </tr> </tbody> </table>	DIAMETER (mm.)	ACCEPTABLE Q'TY	0.1	DISREGARD	0.1 < 0.25	3 (D>5mm)	0.25 <	0	LENGTH	WIDTH	ACCEPTABLE Q'TY	-----	W 0.03	DISREGARD	L 5.0	0.03 < W 0.07	3 (D>5mm)	-----	0.07 < W	FOLLOW ROUND TYPE
DIAMETER (mm.)	ACCEPTABLE Q'TY																						
0.1	DISREGARD																						
0.1 < 0.25	3 (D>5mm)																						
0.25 <	0																						
LENGTH	WIDTH	ACCEPTABLE Q'TY																					
-----	W 0.03	DISREGARD																					
L 5.0	0.03 < W 0.07	3 (D>5mm)																					
-----	0.07 < W	FOLLOW ROUND TYPE																					
8.4.2	MINOR	BUBBLE IN POLARIZER DENT ON POLARIZER	<p style="text-align: right;">unit : mm.</p> <table border="1"> <thead> <tr> <th>DIAMETER</th> <th>ACCEPTABLE Q'TY</th> </tr> </thead> <tbody> <tr> <td>0.2</td> <td>DISREGARD</td> </tr> <tr> <td>0.2 &lt; 0.5</td> <td>2 (D&gt;5mm)</td> </tr> <tr> <td>0.5 &lt;</td> <td>0</td> </tr> </tbody> </table>	DIAMETER	ACCEPTABLE Q'TY	0.2	DISREGARD	0.2 < 0.5	2 (D>5mm)	0.5 <	0												
DIAMETER	ACCEPTABLE Q'TY																						
0.2	DISREGARD																						
0.2 < 0.5	2 (D>5mm)																						
0.5 <	0																						
8.4.3	MINOR	Dot Defect	<table border="1"> <thead> <tr> <th>Items</th> <th>ACC. Q'TY</th> </tr> </thead> <tbody> <tr> <td>Bright dot</td> <td>N 4 (D&gt;5mm)</td> </tr> <tr> <td>Dark dot</td> <td>N 4 (D&gt;5mm)</td> </tr> </tbody> </table> <p>Pixel Define</p>  <p>Not 1: The definition of dot: The size of a defective dot over 1/2 of whole dot is regarded as one defective dot.</p> <p>Not 2: Bright dot: Dots appear bright and unchanged in size in which LCD panel is displaying under black pattern.</p> <p>Not 3: Dark dot: Dots appear dark and unchanged in size in which LCD panel is displaying under pure red, green, blue pattern.</p>	Items	ACC. Q'TY	Bright dot	N 4 (D>5mm)	Dark dot	N 4 (D>5mm)														
Items	ACC. Q'TY																						
Bright dot	N 4 (D>5mm)																						
Dark dot	N 4 (D>5mm)																						

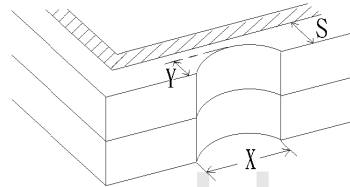
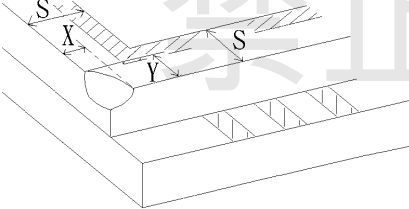
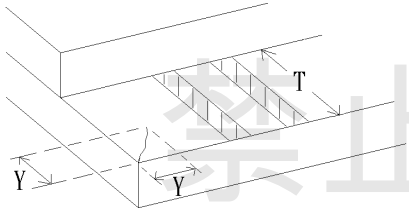
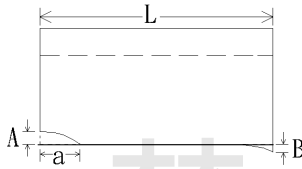
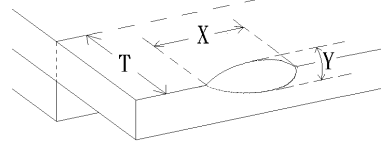
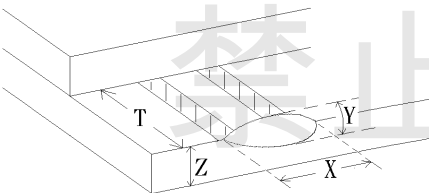
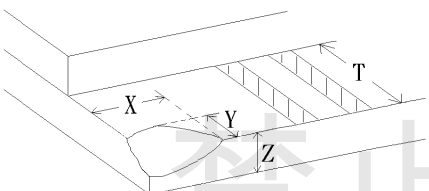
NO.	CLASS	ITEM	JUDGEMENT
8.4.4	MINOR	LCD GLASS CHIPPING	 $Y > S$ Reject
8.4.5	MINOR	LCD GLASS CHIPPING	 $X \text{ or } Y > S$ Reject
8.4.6	MAJOR	LCD GLASS GLASS CRACK	 $Y > (1/2) T$ Reject
8.4.7	MAJOR	LCD GLASS SCRIBE DEFECT	 <ol style="list-style-type: none"> <li><math>a &gt; L/3</math>, <math>A &gt; 1.5\text{mm}</math>. Reject</li> <li>B : ACCORDING TO DIMENSION</li> </ol>
8.4.8	MINOR	LCD GLASS CHIPPING ( ON THE TERMINAL AREA )	 $= (x+y)/2 > 2.5 \text{ mm}$ Reject
8.4.9	MINOR	LCD GLASS CHIPPING ( ON THE TERMINAL SURFACE )	 $Y > (1/3) T$ Reject
8.4.10	MINOR	LCD GLASS CHIPPING	 $Y > T$ Reject