

SPECIFICATION

OF

LIQUID CRYSTAL DISPLAY MODULE



CUSTOMER : URT-STD

Model No. : UMSH-8065MD-17T(REVT)

Model version : 0

Document Revision : 13

CUSTOMER APPROVED SIGNATURE			

This specification need to be signed by purchaser or customer as a specification of products production and delivery from URT. Without signature of this specification , any purchase order for this model no. will be treated and considered that this specification is automatically acknowledged and accepted by purchaser or customer.

 **U.R.T.**  **UNITED RADIANT TECHNOLOGY CORPORATION**

Joe Wu
APPROVED

Ashin Chiu
CHECKED

Jenny Wang
PREPARED

Nov-29-2018
Date

COMPANY : No. 2,Fu-hsing Road,Taichung Economic Processing Zone,Tantzu,Taichung,Taiwan,R.O.C.

TEL: 886-4-25314277

FAX: 886-4-25313067

Revision record

Document Revision	Model No. Version No.	Description	Revision by
0	UMSH-8065MD-T Version No. 0		Tony Chan Jeffry Chen 18-Jul-2007
1	UMSH-8065MD-1T Version No. 0	1.Modify the FPC interface pins.	H.C. Lin Jeffry Chen
2	UMSH-8065MD-2T Version No. 0	1. Add AD board on LCM. 2. Modify the module number from UMSH-8065MD-1T to UMSH-8065MD-2T.	H.C. Lin Jeffry Chen
3	UMSH-8065MD-3T Version No. 0	1. Add touch panel on LCM. 2. Modify the module number from UMSH-8065MD-1T to UMSH-8065MD-3T.	H.C. Lin Jeffry Chen
4	UMSH-8065MD-4T Version No. 0	1. Change to car-using specification. 2. Modify the module number from UMSH-8065MD-1T to UMSH-8065MD-4T.	H.C. Lin Jeffry Chen
5	UMSH-8065MD-5T Version No. 0	Add heater on LCM. 2. Modify the module number from UMSH-8065MD-4T to UMSH-8065MD-5T.	H.C. Lin Jeffry Chen
6	UMSH-8065MD-6T Version No. 0	1. Add touch panel on LCM. 2. Modify the module number from UMSH-8065MD-T to UMSH-8065MD-6T.	H.C. Lin Jeffry Chen 26-Sep-2007
7	UMSH-8065MD-6T Version No. 1	1.Change the touch panel supplier. 2.Change the FPC outline of T/P.	H.C. Lin Jeffry Chen
8	UMSH-8065MD-6T Version No. 2	1. Modify the specification of DC Characteristics. 2. Modify the description of interface pin. 3. Modify the Back-light only Specification	H.C. Lin Jeffry Chen 01-Apr-2008
9	UMSH-8065MD-6T Version No. 3	1. Modify the specification of AC Characteristics. 2. Modify the description of interface pin.	H.C. Lin Jeffry Chen 27-Feb-2009
10	UMSH-8065MD-17T Version No. 0	1. Improve the T/P newton ring. 2. Modify the module number from UMSH-8065MD-6T to UMSH-8065MD-17T.	Ken. Lin Jeffry Chen 16-Oct-2009
11	UMSH-8065MD-17T Version No. 1	Modify the Back-light only Specification	H.C. Lin Jeffry Chen 14-Apr-2010
12	UMSH-8065MD-17T(REVT) Version No.0	1. Modify the supplier of the Resistance T/P. 2. Redraw the block diagram. 3. Modify the outline dimension. 4. Modify the module number from UMSH-8065MD-17T to UMSH-8065MD-17T(REVT).	William Don Dennis Lee 27-Aug-2014
13	UMSH-8065MD-17T(REVT) Version No.0	Modify the packing mode.	Design Section 29-Nov-2018
		Revision 13 ; UMSH-8065MD-17T(REVT) Ver. 0 ; November-29-2018	Page: 2

CONTENTS:

No.	Item	Page
1	BASIC SPECIFICATION 1.1 Mechanical Specification 1.2 Display Specification 1.3 Outline Dimension 1.4 Block Diagram 1.5 Interface Pin	4 4 5~6 7 8~10
2	ELECTRICAL CHARACTERISTICS 2.1 Absolute Maximum Ratings 2.2 DC Characteristics 2.2.1 Back-light 2.3 Command 2.4 AC Characteristics 2.5 Touch Panel Specifications	11 12 12 13 14~24 25~26
3	OPTICAL CHARACTERISTICS 3.1 Condition 3.2 Definition of Optical Characteristics	27 28~29
4	RELIABILITY	30
5	PRODUCT HANDING AND APPLICATION	31
6	DATECODE	32
7	PACKING & LOTNO	33~34
8	INSPECTION STANDARD	35~39

1. BASIC SPECIFICATION

1.1 Mechanical specifications

Items	Nominal Dimension	Unit
Active screen size	3.5" diagonal	-
Dot Matrix	320*RGB*240	Pixel
Module Size (W x H x T)	76.9 x 63.9 x 4.3	mm.
Active Area (W x H)	70.08 x 52.56	mm.
Dot Pitch (W x H)	0.219 x 0.219	mm.
Color depth	262K	color
Interface	8-bits serial/24-bits parallel RGB / CCIR601/656	-
Driving IC Package	COG	-
Module Weight	43±10%	g

* The maximum color depth of this driver IC is 262K colors ,not 16.7M.

1.2 Display specification

Display	Descriptions	Note
LCD Type	a-Si TFT	-
LCD Mode	TN / Normally White	-
Polarizer Mode	Transmissive	-
Polarizer Surface	Normal	-
Pixel arrangement	RGB-stripe	-
Backlight Type	LED	-
Viewing Direction(Gray inversion)	6 O'clock Direction	1

*Color tone is slightly changed by temperature and driving voltage.

Note 1 : The viewing direction defined in this specification is according to the rubbing direction of its TFT surface treatment by the TFT glass manufacturer. The grayscale inversion is at this direction as well. However, the optimal viewing direction for human view is normally where the color does not change to grayscale inversion, and this would be the opposite site of the specified viewing direction in this specification. In any case we advise customers to judge by themselves, and be aware of this phenomenon.

1.3 Outline dimension

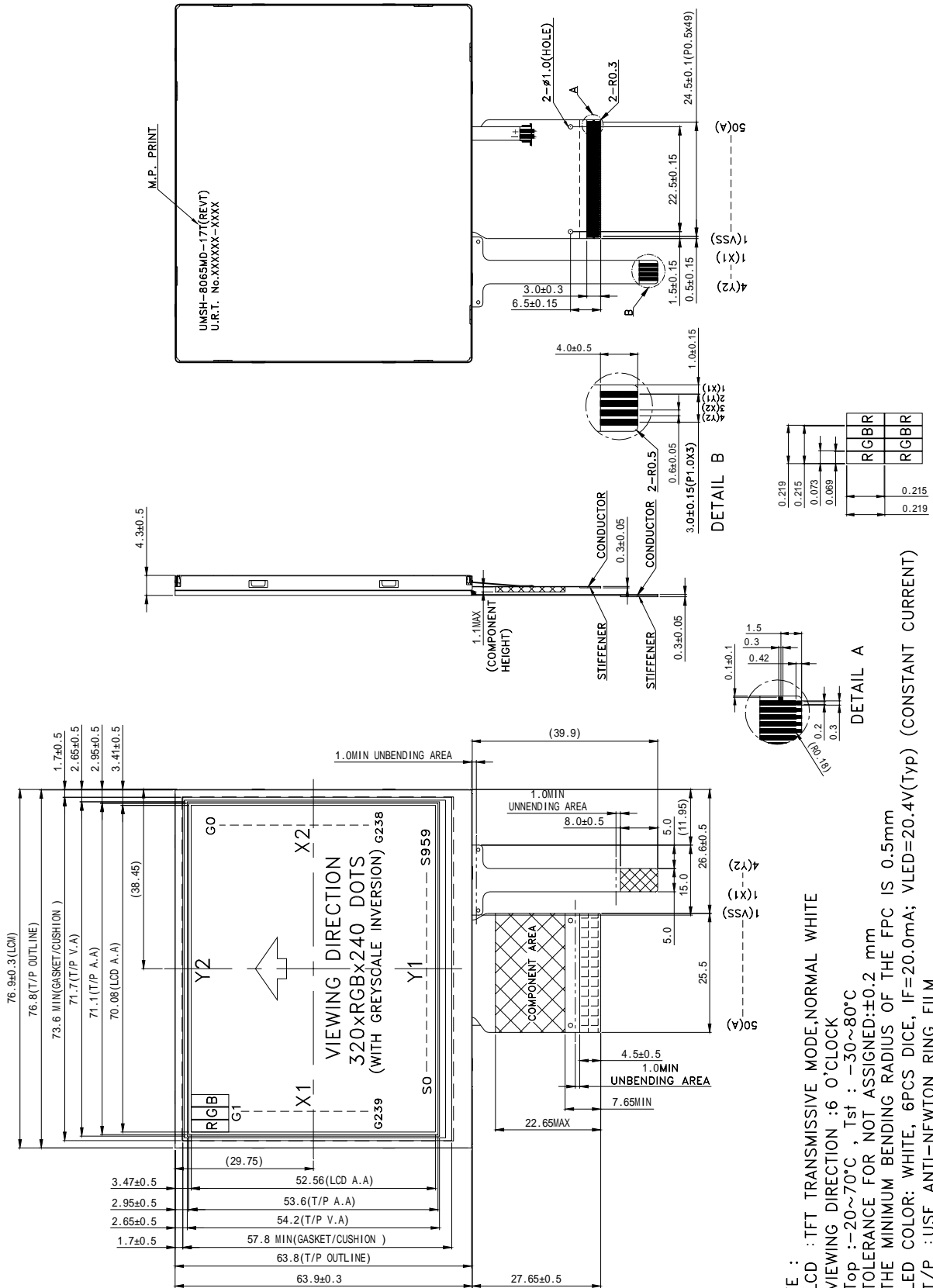

- NOTE :
- LCD : TFT TRANSMISSIVE MODE,NORMAL WHITE
 - VIEWING DIRECTION : 6 O'CLOCK
 - Top :-20~70°C , Tst : -30~80°C
 - TOLERANCE FOR NOT ASSIGNED:±0.2 mm
 - THE MINIMUM BENDING RADIUS OF THE FPC IS 0.5mm
 - LED COLOR: WHITE, 6PCS DICE, IF=20.0mA; VLED=20.4V(Typ) (CONSTANT CURRENT)
 - T/P : USE ANTI-NEWTON RING FILM
 - DRIVER IC : HX8238-A02

Structure and Area definition

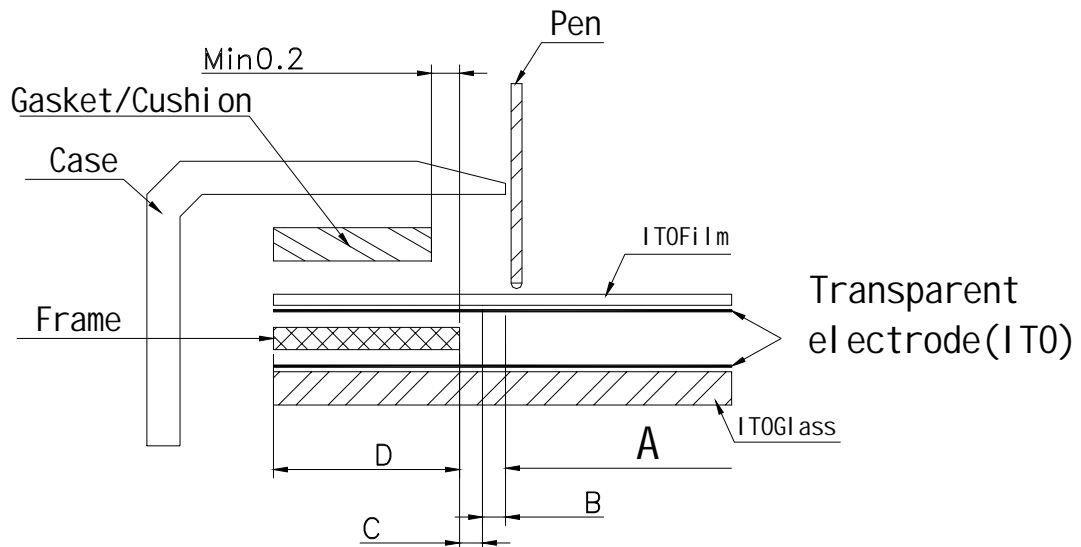

A:Active area

The area which guarantees a touch panel operation with the following characteristics when passed.

- (1) Operation force, (2) Electric characteristics,
- (3) Tapping durability, (4) Pen sliding durability.

B:operation non-guaranteed area

The area which does not guarantee a touch panel operation and its function when this area is pressed, touch panel shows degradation of its performance and durability such as a pen sliding durability becomes about one-tenth compared with the active area (Area-a) as guaranteed area) and its operation force requires about double. About 0.5mm outside from a boundary of the active corresponds to this area.

C:Pressing prohibition area.

The area which forbids pressing, because an excessive load is applied a transparent electrode and a serious damage is given to touch panel function by pressing.

D:Non-Active area

The area which does not activate even if passed.

1.4 Block diagram:

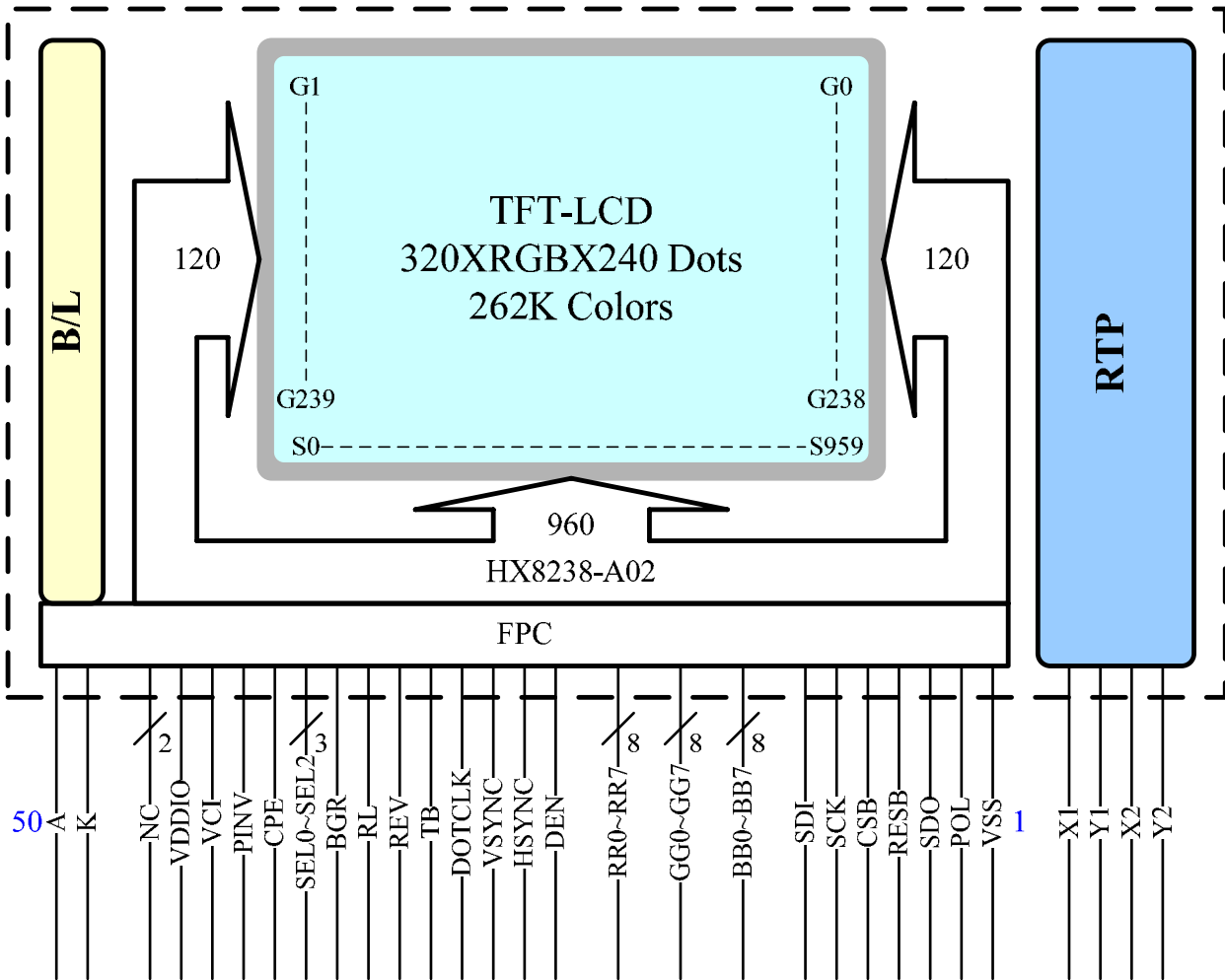

1.5 Interface Pin Connection:

Pin No.	Pin Name	I/O	Description
1	VSS	P	System ground pin of the IC. - Connect to system ground
2	POL	O	Polarity signal to monitor VCOM signal. - Leave it OPEN when not used
3	SDO	O	Data output pin in serial mode. - Leave it OPEN when not used
4	RESB	I	System reset pin. Internal pull high.
5	CSB	I	Chip select pin of serial interface. Internal pull high. - Leave it OPEN when not used.
6	SCK	I	Clock pin of serial interface. Internal pull high. - Leave it OPEN when not used
7	SDI	I	Data input pin in serial mode. Internal pull high. - Leave it OPEN when not used
8~31	BB [0:7] GG [0:7] RR [0:7]	I	Graphic Data Input Pins. Internal pull low. - RR [0:7]: Red Data - 8-bits - GG [0:7]: Green Data - 8-bits - BB [0:7]: Blue Data - 8-bits For 8 bit interface, only RR[0:7] are used. For unused pins, please connect to VSS or floating.
32	DEN	I	Display enable pin from controller. Connect to VDDIO or floating if not used.
33	HSYNC	I	Line synchronization signal. Internal pull high. - Fixed to VDDIO or floating if not used
34	VSYNC	I	Frame synchronization signal. Internal pull high. - Fixed to VDDIO or floating if not used.
35	DOTCLK	I	Dot-clock signal and oscillator source.

Pin No.	Pin Name	I/O	Description																																													
36	TB	I	Input pin to select the Gate driver scan direction. - Connect to VSS for Gate scan from G239 to G0 (reverse scan) - Connect to VDDIO for Gate scan from G0 to G239 (normal scan)																																													
37	REV	I	Input pin to select the display reversion. - Connect to VDDIO mapping data '0' to maximum pixel voltage for normally white panel - Connect to VSS for mapping data '0' to minimum pixel voltage for normally black panel																																													
38	RL	I	Input pin to select the Source driver data shift direction. - Connect to VDDIO for display first RGB data at S0-S2. - Connect to VSS for display first RGB data at S959-S957.																																													
39	BGR	I	Input pin to select the color mapping. - Connect to VDDIO for Blue-Green-Red mapping. - Connect to VSS for Red-Green-Blue mapping.																																													
40~42	SEL0~2	I	Input pin to select input interface mode.																																													
			<table border="1"> <thead> <tr> <th>SEL2</th> <th>SEL1</th> <th>SEL0</th> <th>Format</th> <th>Operating Frequency</th> </tr> </thead> <tbody> <tr> <td>0</td> <td>0</td> <td>0</td> <td>Parallel-RGB data format (only support stripe type color filter)</td> <td>7.5MHz</td> </tr> <tr> <td>0</td> <td>0</td> <td>1</td> <td>Serial-RGB data format</td> <td>19.5MHz</td> </tr> <tr> <td>0</td> <td>1</td> <td>0</td> <td>CCIR 656 data format (640RGB)</td> <td>24.54MHz</td> </tr> <tr> <td>0</td> <td>1</td> <td>1</td> <td>CCIR 656 data format (720RGB)</td> <td>27MHz</td> </tr> <tr> <td>1</td> <td>0</td> <td>0</td> <td>YUV mode A data format (Cr-Y-Cb-Y)</td> <td>24.54MHz</td> </tr> <tr> <td>1</td> <td>0</td> <td>1</td> <td>YUV mode A data format (Cr-Y-Cb-Y)</td> <td>27MHz</td> </tr> <tr> <td>1</td> <td>1</td> <td>0</td> <td>YUV mode B data format (Cb-Y-Cr-Y)</td> <td>27MHz</td> </tr> <tr> <td>1</td> <td>1</td> <td>1</td> <td>YUV mode B data format (Cb-Y-Cr-Y)</td> <td>24.54MHz</td> </tr> </tbody> </table>	SEL2	SEL1	SEL0	Format	Operating Frequency	0	0	0	Parallel-RGB data format (only support stripe type color filter)	7.5MHz	0	0	1	Serial-RGB data format	19.5MHz	0	1	0	CCIR 656 data format (640RGB)	24.54MHz	0	1	1	CCIR 656 data format (720RGB)	27MHz	1	0	0	YUV mode A data format (Cr-Y-Cb-Y)	24.54MHz	1	0	1	YUV mode A data format (Cr-Y-Cb-Y)	27MHz	1	1	0	YUV mode B data format (Cb-Y-Cr-Y)	27MHz	1	1	1	YUV mode B data format (Cb-Y-Cr-Y)	24.54MHz
			SEL2	SEL1	SEL0	Format	Operating Frequency																																									
			0	0	0	Parallel-RGB data format (only support stripe type color filter)	7.5MHz																																									
			0	0	1	Serial-RGB data format	19.5MHz																																									
			0	1	0	CCIR 656 data format (640RGB)	24.54MHz																																									
			0	1	1	CCIR 656 data format (720RGB)	27MHz																																									
			1	0	0	YUV mode A data format (Cr-Y-Cb-Y)	24.54MHz																																									
			1	0	1	YUV mode A data format (Cr-Y-Cb-Y)	27MHz																																									
1	1	0	YUV mode B data format (Cb-Y-Cr-Y)	27MHz																																												
1	1	1	YUV mode B data format (Cb-Y-Cr-Y)	24.54MHz																																												

Pin No.	Pin Name	I/O	Description
43	CPE	I	Input pin to enable internal charge pump circuit. Internal pull high. - Connect to VDDIO to enable internal charge pump. - Connect to VSS to disable internal charge pump
44	PINV	I	Control the polarity of POL signal. Internal pull low. - Connect to VDDIO, POL phase is reversed with internal VCOM signal. - Connect to VSS, POL phase is same with internal VCOM signal.
45	VCI	P	Power Supply for Analog Circuits.
46	VDDIO	P	Voltage input pin for I/O logic.
47	NC	-	No connection.
48	NC	-	No connection.
49	K	P	Backlight LED's cathode.
50	A	P	Backlight LED's anode.

Touch screen panel pin:

1	X1	-	Touch screen.
2	Y1	-	Touch screen.
3	X2	-	Touch screen.
4	Y2	-	Touch screen.

2. ELECTRICAL CHARACTERISTICS

2.1 Absolute Maximum Ratings

Items	Symbol	Min.	Max.	Unit
Input voltage	VCI	VSS-0.3	5.0	V
Supply Voltage	VDDIO	VSS-0.3	4.0	V
Operate temperature range	TOP	-20	70	°C
Storage temperature range	TST	-30	80	°C

2.2 DC Characteristics

Items	Symbol	Min.	Typ.	Max.	Unit	Condition
Power supply voltage	VCI	2.5	3.3	3.6	V	-
Power supply pin of IO pins	VDDIO	1.4	3.3	3.6	V	-
Logic input voltage	H	$0.8 \cdot V_{DDIO}$	-	VDDIO	V	-
	L	0	-	$0.2 \cdot V_{DDIO}$	V	-
Logic output voltage	H	$0.9 \cdot V_{DDIO}$	-	VDDIO	V	$I_{out} = 100\mu A$
	L	0	-	$0.1 \cdot V_{DDIO}$	V	$I_{out} = 100\mu A$
Current consumption	$I_{VCI+VDDIO}$	-	-	16	mA	NOTE
Dot Clock	DCK	-	7.5	10	MHz	-
Serial Clock	XSCK	-	19.5	30	MHz	-

NOTE :

The method to illuminate the LCD panel is using the 2-4-7 command under the measuring condition.

Measuring Condition :

Standard Value MAX.

T_a = 25°C

VCI = 3.3V

VDDIO = 3.3V

Dot Clock = 7.5MHz

Display Patten



0 gray black pattern

2.2.1 Back-light Characteristics

Parameter	Symbol	Min	Typ	Max	Unit	Test Condition	Note
Supply Current	I_f	-	20	-	mA	$T_a = 25^\circ C$	-
Supply Voltage	VF	-	20.4	-	V	$T_a = 25^\circ C$	-
Half-Life Time	Lf	-	50000	-	hrs	$T_a = 25^\circ C$	-

Note1: The " Half-Life Time" is defined as the LED chip brightness decreases to 50% than original brightness, Based on $T_a 25 \pm 2^\circ C, 60 \pm 10\% RH$ condition .

2.3 Command (Recommend by U.R.T.)

LCD_Initial_HX-8238:

COMMAND	CODE	DESCRIPTION
R02H	0200	LCD-Driving- Waveform Control
R03H	6364	Power control 1
R04H	0440	Input Data and Color Filter Control
R0DH	3221	Power Control 2
R0EH	3100	Power Control 3

Adjust the Gamma Curve:

COMMAND	CODE	DESCRIPTION
R30H	0000	Gamma Control 1
R31H	0407	Gamma Control 1
R32H	0202	Gamma Control 1
R33H	0000	Gamma Control 1
R34H	0505	Gamma Control 1
R36H	0707	Gamma Control 1
R37H	0000	Gamma Control 1
R3AH	0904	Gamma Control 2
R3BH	0904	Gamma Control 2

2.4 AC Characteristics

2.4.1 8-bits serial/24-bits parallel RGB

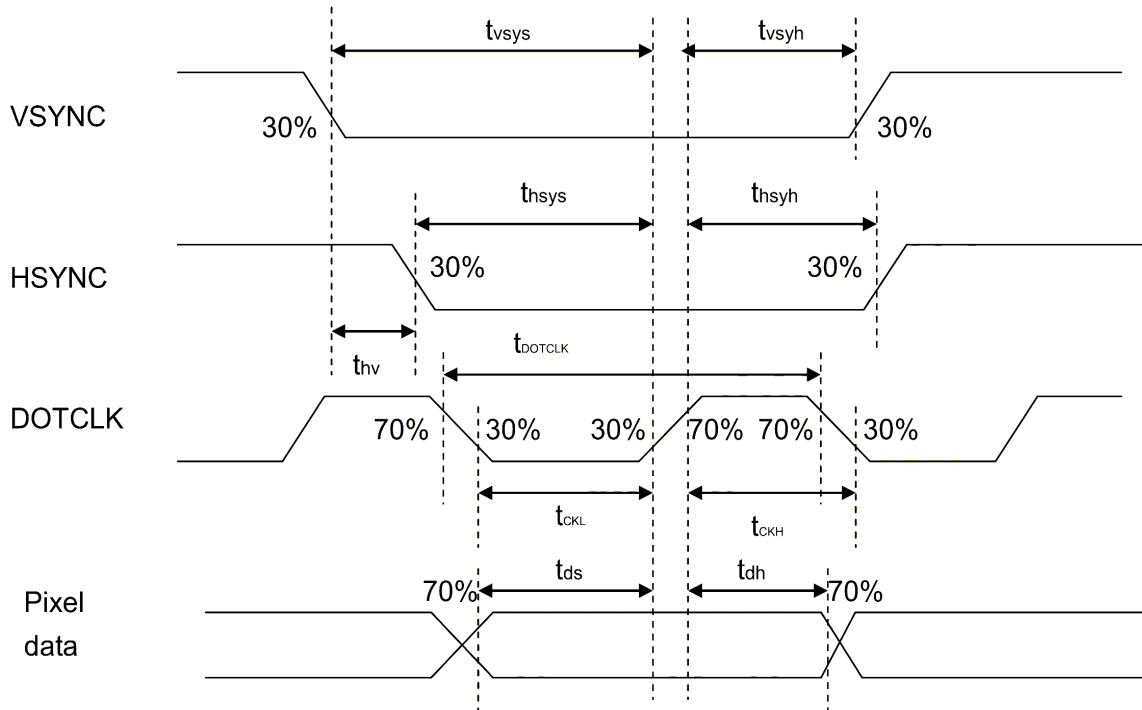

Figure 1. Pixel Timing

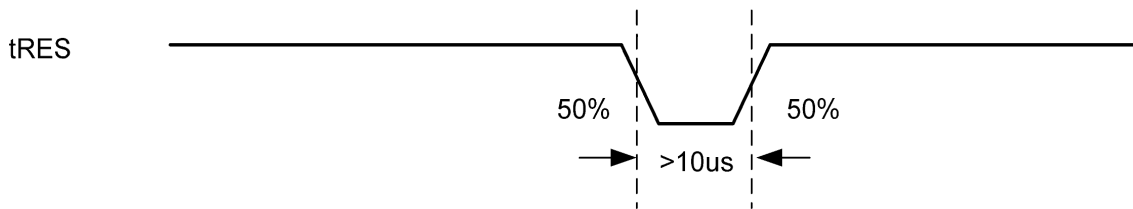
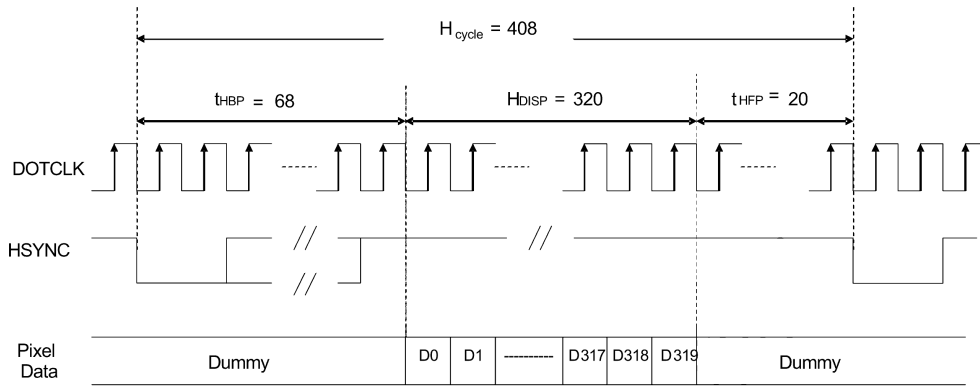

Figure 2. tRES Timing

Characteristics	Symbol	Min.		Typ.		Max.		Unit
		24 bit	8 bit	24 bit	8 bit	24 bit	8 bit	
DOTCLK Frequency	fDOTCLK	-		6.5	19.5	10	30	MHz
DOTCLK Period	tDOTCLK	100	33.3	154	51.3	-	-	ns
Vertical Sync Setup Time	tvsys	20	10	-	-	-	-	ns
Vertical Sync Hold Time	tvsyh	20	10	-	-	-	-	ns
Horizontal Sync Setup Time	thsys	20	10	-	-	-	-	ns
Horizontal Sync Hold Time	thsyh	20	10	-	-	-	-	ns
Phase difference of Sync Signal Falling Edge	thv	-4		-		+4		tDOTCLK
DOTCLK Low Period	tCKL	50	15	-	-	-	-	ns
DOTCLK High Period	tCKH	50	15	-	-	-	-	ns
Data Setup Time	tds	12	8	-	-	-	-	ns
Data hold Time	tdh	12	8	-	-	-	-	ns
Reset pulse width	tRES	10		-		-		us

Note: External clock source must be provided to DOTCLK pin of HX8238-A. The driver will not operate if absent of the clocking signal.

Table 1. Pixel & tRES Timing



a) Horizontal Data Transaction Timing

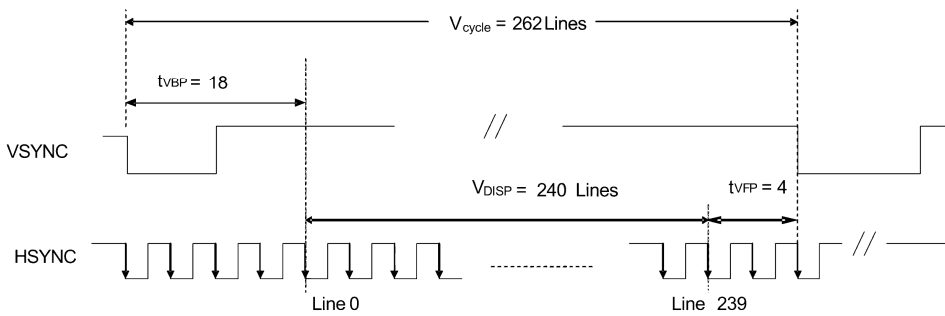

b) Vertical Data Transaction Timing

Figure 3. Data Transaction Timing in Parallel RGB (24 bit) Interface (SYNC Mode)

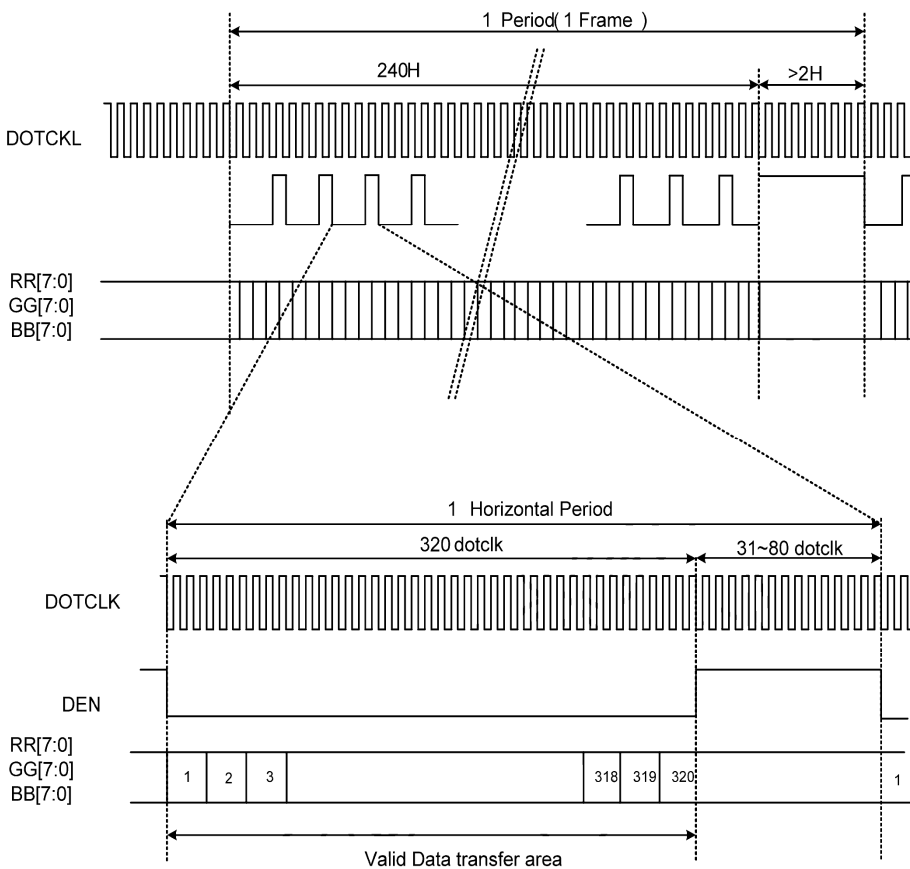
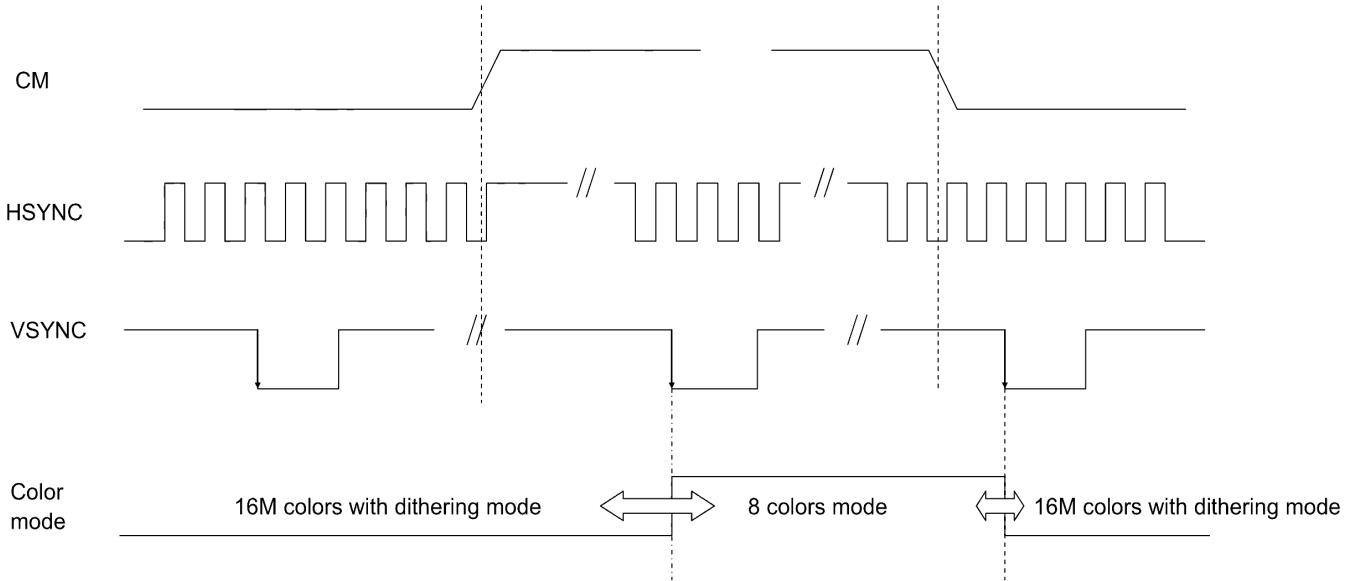

Figure 4. Data Transaction Timing in Parallel RGB (24 bit) Interface (DE Mode)

Characteristics	Symbol	Min.		Typ.		Max.		Unit
		24 bit	8 bit	24 bit	8 bit	24 bit	8 bit	
DOTCLK Frequency	fDOTCLK	-	-	6.5	19.5	10	30	MHz
DOTCLK Period	tDOTCLK	100	33.3	154	51.3	-	-	ns
Horizontal Frequency (Line)	fH	-		15.72		22.35		KHz
Vertical Frequency (Refresh)	fV	-		60		90		Hz
Horizontal Back Porch	tHBP	-	-	68	204	-	-	tDOTCLK
Horizontal Front Porch	tHFP	-	-	20	60	-	-	tDOTCLK
Horizontal Data Start Point	tHBP	-	-	68	204	-	-	tDOTCLK
Horizontal Blanking Period	tHBP + tHFP	-	-	88	264	-	-	tDOTCLK
Horizontal Display Area	HDISP	-	-	320	960	-	-	tDOTCLK
Horizontal Cycle	Hcycle	-	-	408	1224	450	1350	tDOTCLK
Vertical Back Porch	tVBP	-		18		-		Lines
Vertical Front Porch	tVFP	-		4		-		Lines
Vertical Data Start Point	tVBP	-		18		-		Lines
Vertical Blanking Period	tVBP + tVFP	-		22		-		Lines
VS pulse width	tWV	-		4		-		Lines
Vertical Display Area	NTSC	-		240		-		Lines
	PAL			280(PALM=0)				
				288(PALM=1)				
Vertical Cycle	NTSC	-		262		350		Lines
	PAL			313				

Table 2. Data Transaction Timing in Normal Operating Mode



Note: The color mode conversion starts at the first falling edge of VSYNC after stage change of CM.

Figure 5. Color Mode Conversion Timing

2.4.2 CCIR601 Timing:

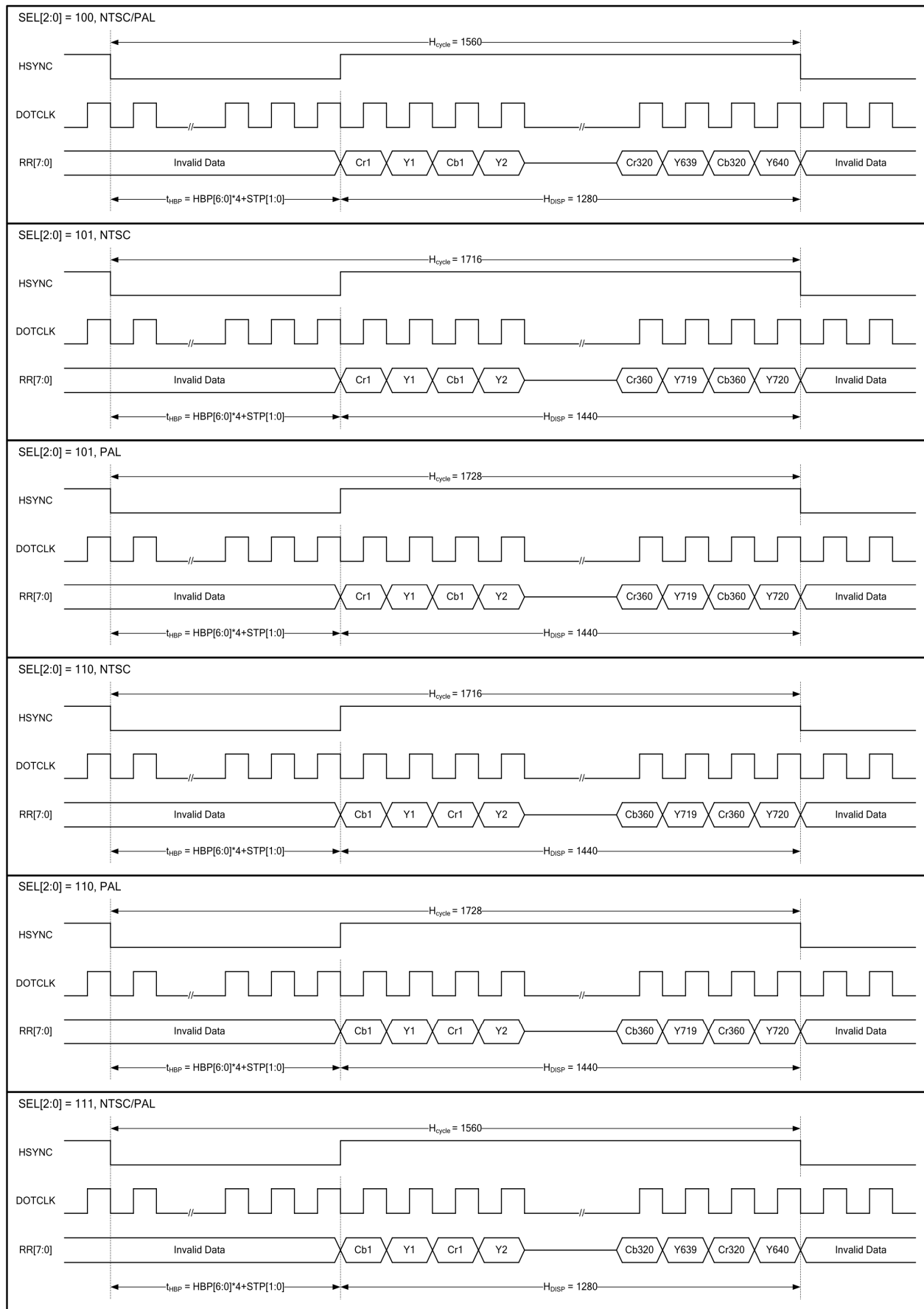

Figure 6. CCIR601 Horizontal Timing

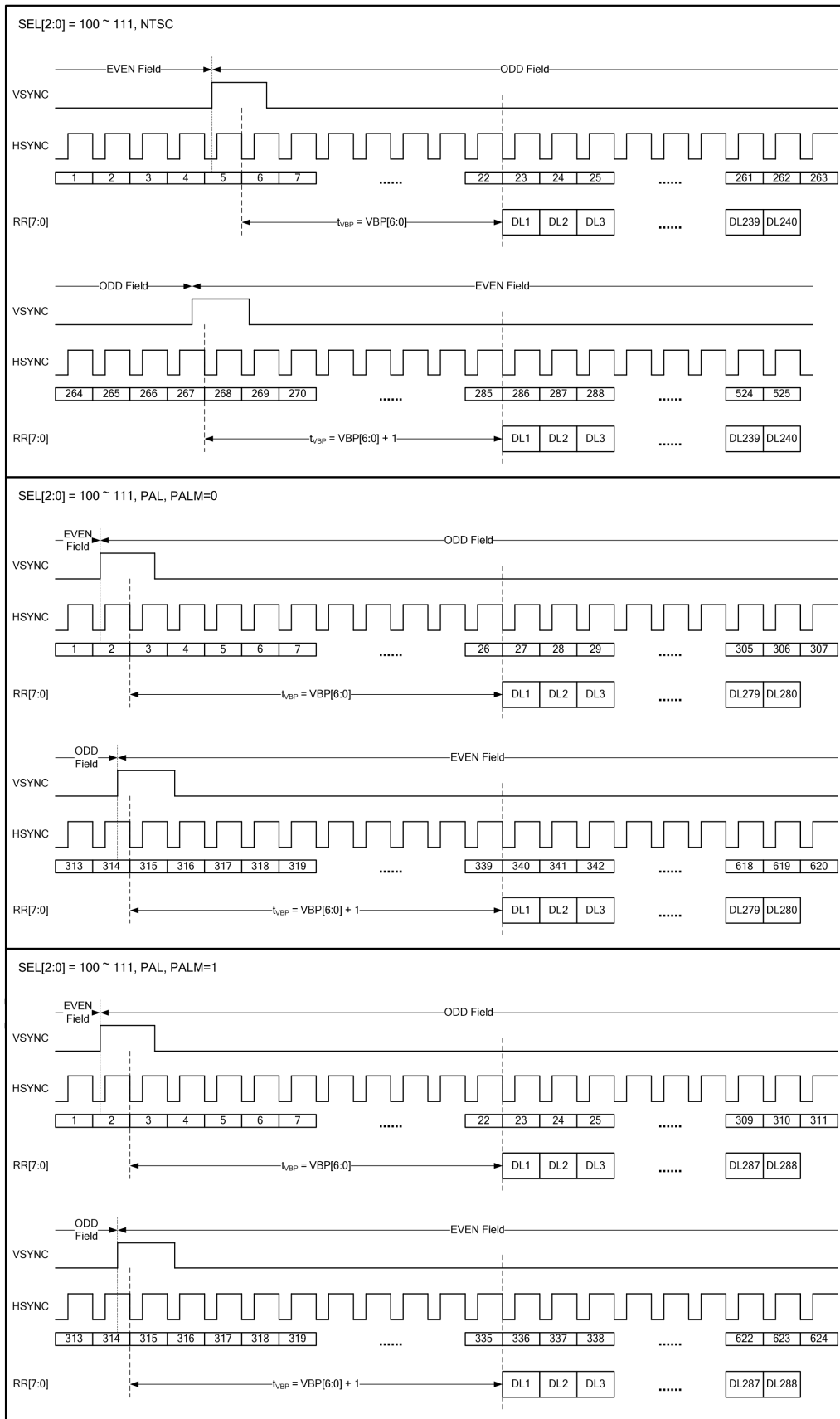

Figure 7. CCIR601 Vertical Timing

2.4.3 CCIR656 Timing:

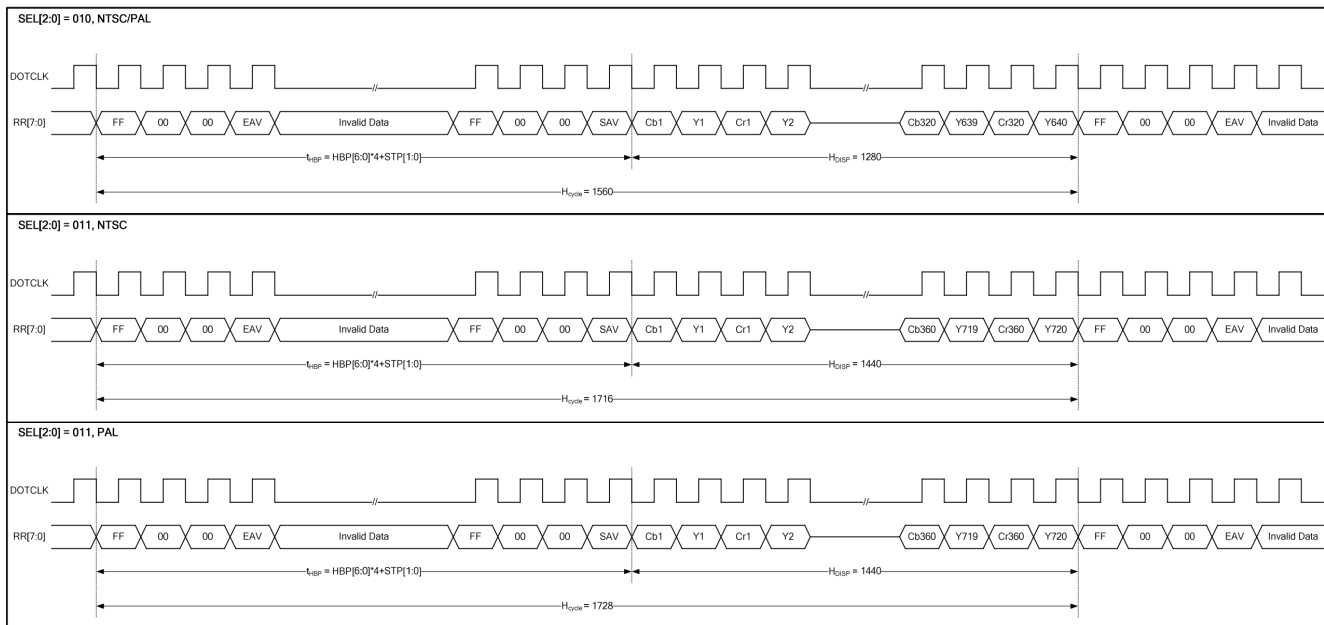

Figure 8. CCIR656 Horizontal Timing

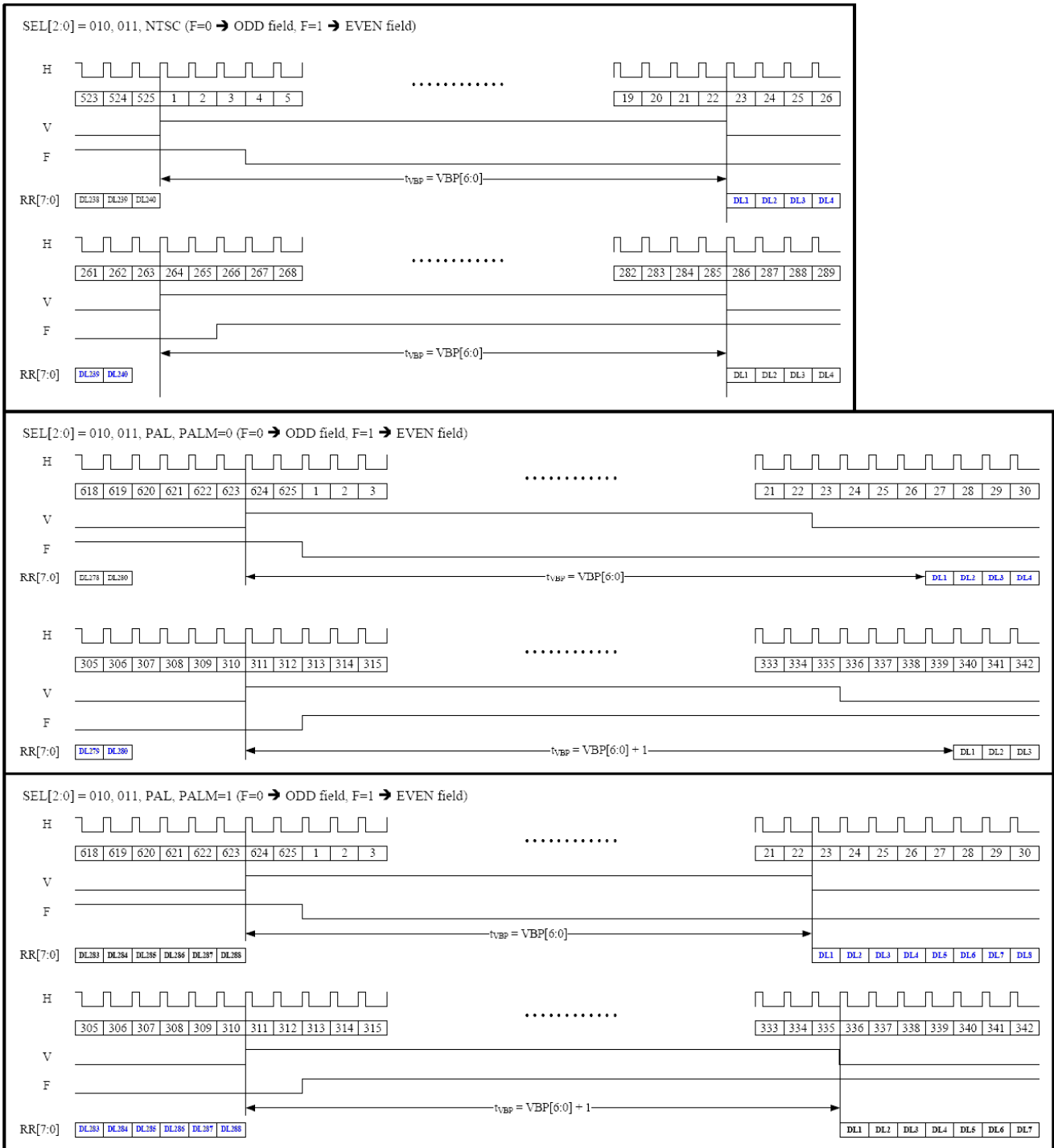
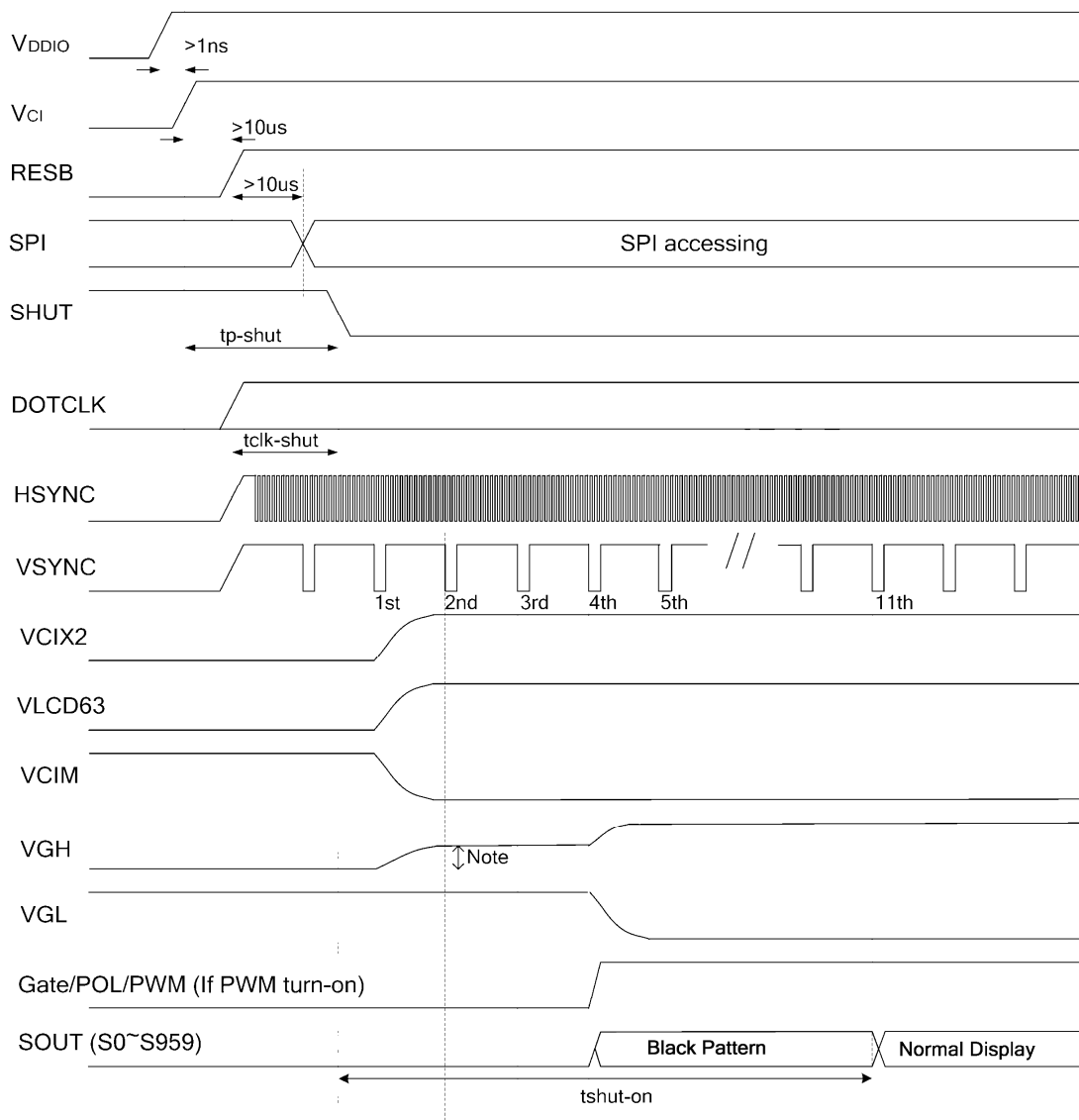

Figure 9. CCIR656 Vertical Timing

2.4.4 Power Up Sequence:



Note: There is a diode between VCIX2 and VGH. Switch on VCIX2 will move VGH up.

Figure 10. Power Up Sequence with SHUT

Characteristics	Symbol	Min.	Typ.	Max.	Unit
VCI/ VDDIO on to falling edge of SHUT	tp-shut	1	-	-	us
DOTCLK to falling edge of SHUT	tclk-shut ⁽¹⁾	1	-	-	clk
Falling edge of SHUT to display start - 1 line: 408 clk - 1 frame: 262 line - DOTCLK = 6.5MHz	tshut-on ⁽²⁾	-	-	11	frame

Note: (1) It is necessary to input DOTCLK before the falling edge of SHUT.

(2) Display starts at 11th falling edge of VSTNC after the falling edge of SHUT. The display starts at the falling edge of VSYNC which is determined by BLT[1:0] of R04h.

Table 3. Power Up Sequence

2.4.5 Power Down Sequence:

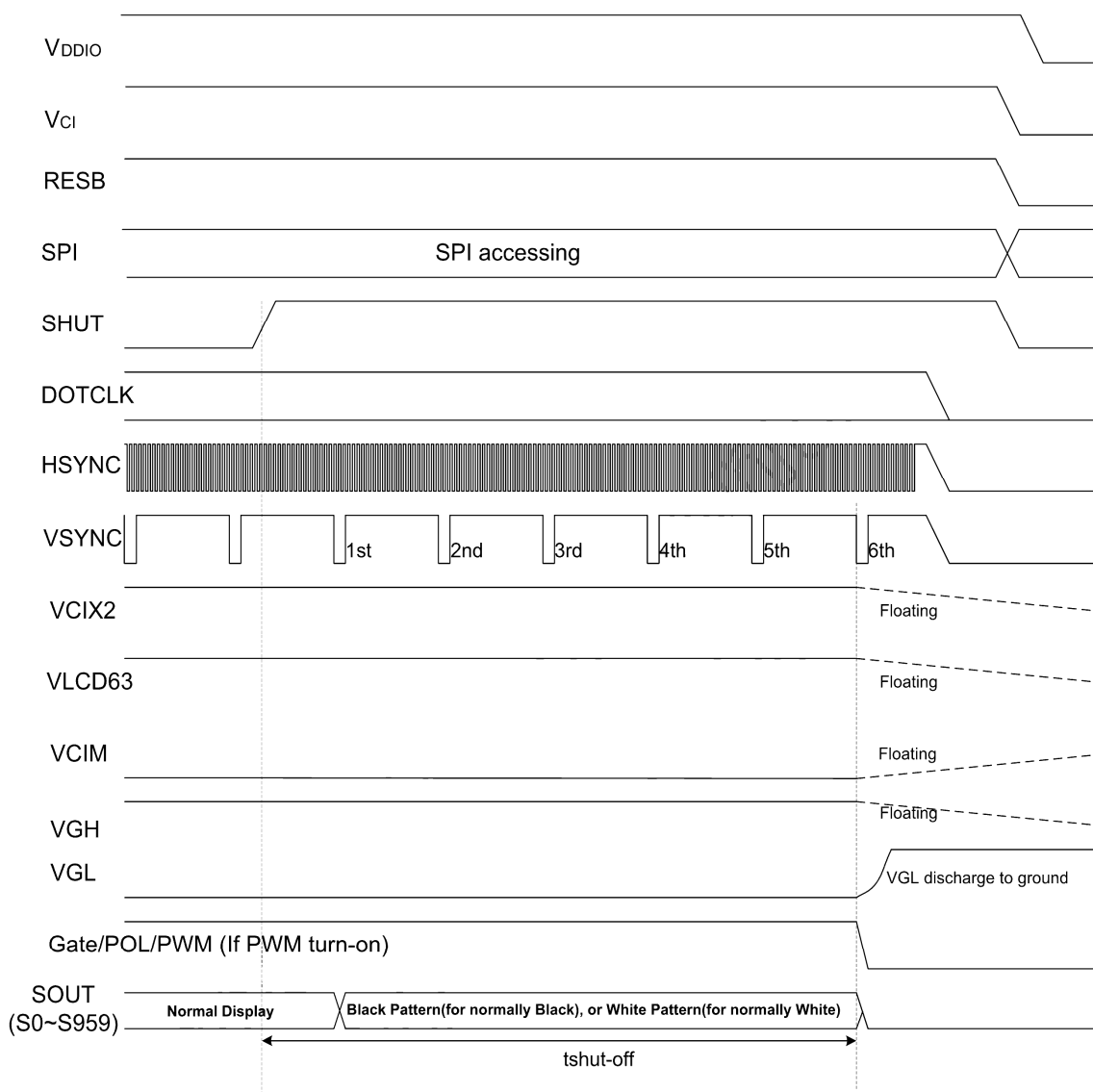

Figure 11. Power Down Sequence with SHUT

Characteristics	Symbol	Min.	Typ.	Max.	Unit
Rising edge of SHUT to display off - 1 line: 408 clk - 1 frame: 262 line - DOTCLK = 6.5MHz	tshut-off	-	-	6	frame

Note: DOTCLK must be maintained at least 6 frames after the rising edge of SHUT.
Display become off at the 6th falling edge of VSTNC after the falling edge of SHUT.
If RESET signal is necessary for power down, provide it after the 6-frames-cycle of the SHUT period.

Table 4. Power Down Sequence

2.4.6 SPI Timing:

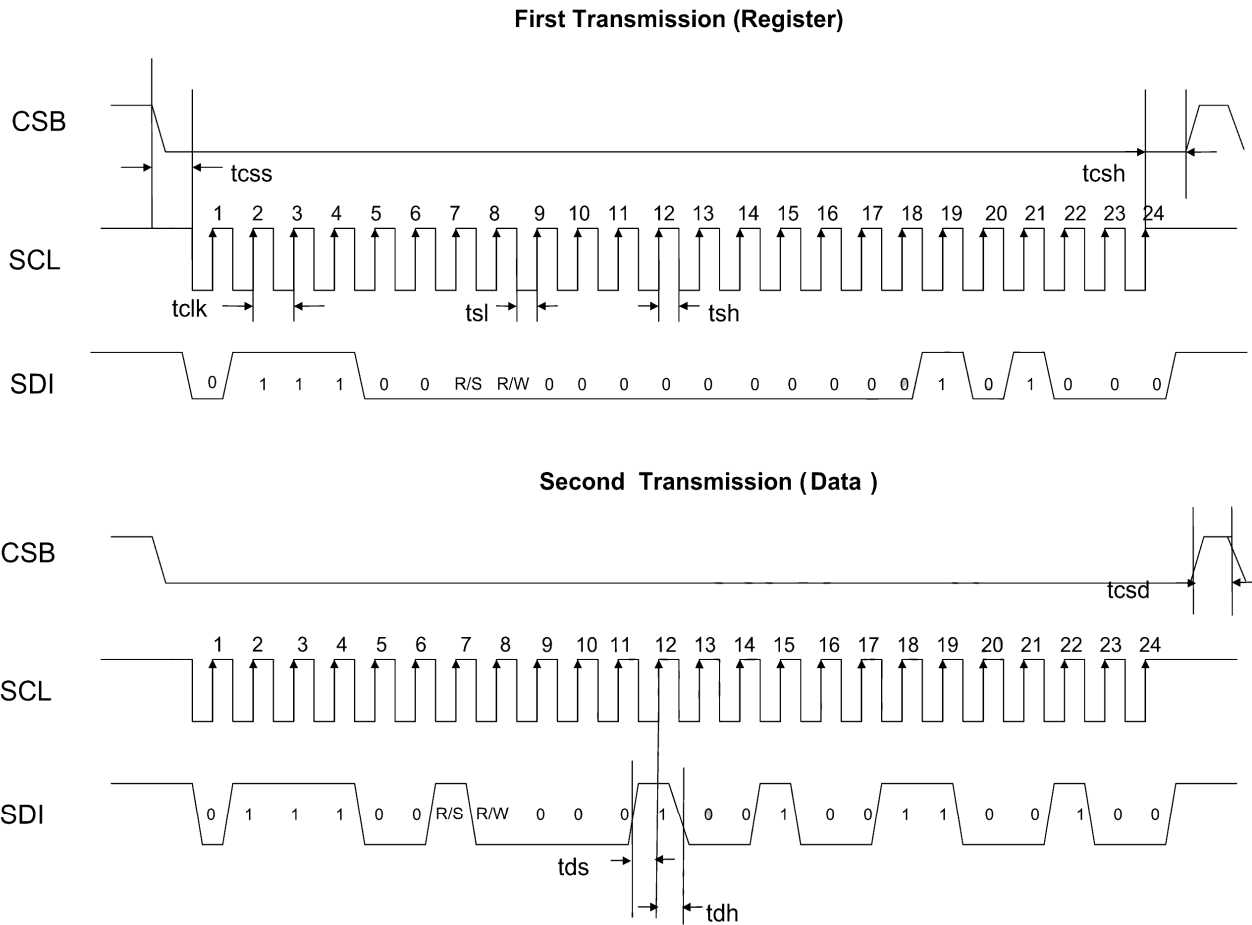

Note: The example writes "0x1264h" to register R28h.
SPID connected to VSS.

Figure 12. SPI interface Timing Diagram & Write SPI Example

Characteristics	Symbol	Min.	Typ.	Max.	Unit
Serial Clock Frequency	fclk	-	-	20	MHz
Serial Clock Cycle Time	tclk	50	-	-	ns
Clock Low Width	tsl	25	-	-	ns
Clock High Width	tsh	25	-	-	ns
Clock Rising Time	trs	-	-	30	ns
Clock Falling Time	tfl	-	-	30	ns
Chip Select Setup Time	tcSS	0	-	-	ns
Chip Select Hold Time	tcSH	10	-	-	ns
Chip Select High Delay Time	tcSD	20	-	-	ns
Data Setup Time	tds	5	-	-	ns
Data Hold Time	tdh	10	-	-	ns

Table 5. SPI Timing

2.5 Touch Panel Specifications

Display	Descriptions	Note
Type	4-wires Analog Resistive Touch Panel	-
Structure	ITO Film : T=0.188mm	-
	ITO Glass : T=0.7mm	-
Surface Hardness	3H	3H pencil, pressure 500g/45° (JIS-K5600)
Input mode	Stylus or Finger	-
Operating Force (Minimum Active Force)	100 gf	Stylus R0.8mm (Active Area toward inner 2mm)
Connector Type	FPC	-

2.5.1 Electric Characteristics

Items	Descriptions	Note
Linearity	X-axis 1.5%	Active Area toward inner 2mm
	Y-axis 1.5%	
Terminal Resistance	X-axis : 350~950Ω	-
	Y-axis : 100~700Ω	-

2.5.2 Durability Test

Items	Condition
Finger Touch Test	Repeating impact the surface of touch panel 1,000k times by R8.0 silicon rubber under 250g loading and 2 times/sec speed.
Pen Sliding Test	Drawing line in 30mm length at same location of touch panel surface 100k times by R0.8mm plastic stylus under 250g loading and 60mm/sec moving speed.

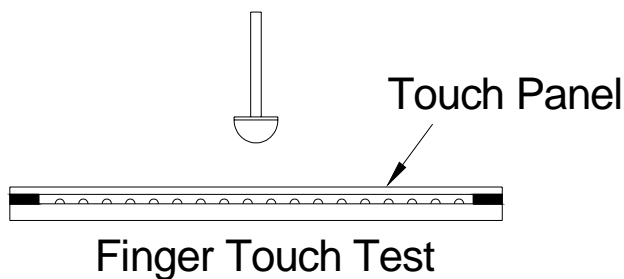
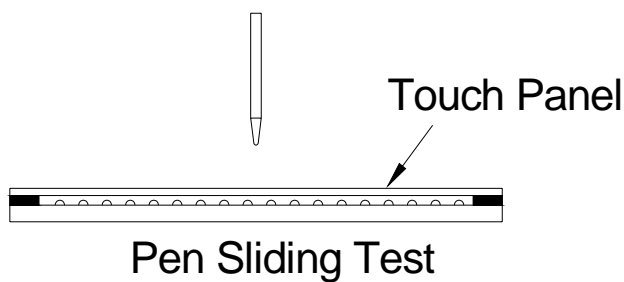

(Durability Test Position)

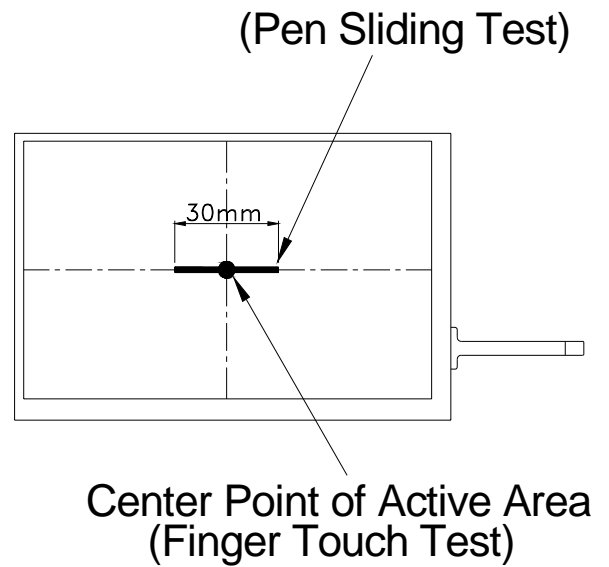

3. OPTICAL CHARACTERISTICS

3.1 Characteristics

Electrical and Optical Characteristics

No.	Item			symbol / temp.	Min.	Typ.	Max.	Unit	Note	
1	Response Time			Tr	25 °C	-	15	20	ms	2
				Tf		-	35	50		
2	Viewing Angle	Hor.	Cr ≥ 10	θ_{2+}	$\Phi = 0^\circ$	60	80	-	degree	3
				θ_{2-}	$\Phi = 180^\circ$	60	80	-		
		Ver.		θ_{1+}	$\Phi = 270^\circ$	60	80	-		
				θ_{1-}	$\Phi = 90^\circ$	30	45	-		
3	Contrast Ratio			Cr	25 °C	150	250	-	-	4
4	Red x-code			Rx	25 °C	0.58	0.63	0.68	-	5
	Red y-code			Ry		0.30	0.35	0.40		
	Green x-code			Gx		0.29	0.34	0.39		
	Green y-code			Gy		0.55	0.60	0.65		
	Blue x-code			Bx		0.09	0.14	0.19		
	Blue y-code			By		0.06	0.11	0.16		
	White x-code			Wx		0.27	0.32	0.37		
	White y-code			Wy		0.31	0.36	0.41		
	Brightness			Y		200	300	-		
5	Brightness Uniformity				25 °C	80	-	-	%	6

3.2 Definition of optical characteristics

Measurement condition :

Transmissive and Transflective type

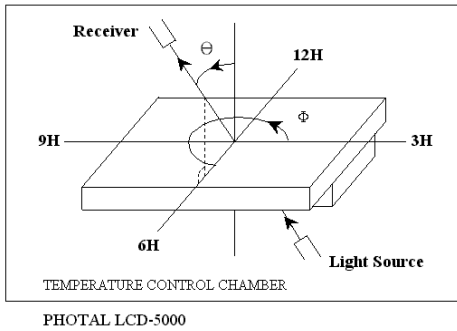

[Note 1] Definition of LCD Driving Vop and Waveform :

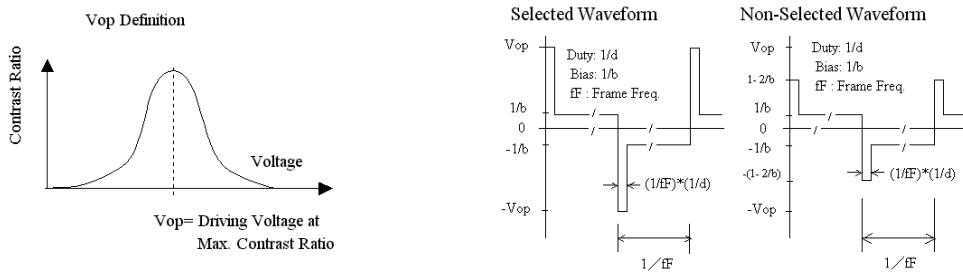

[Note 2] Definition of Response Time

for Positive type :

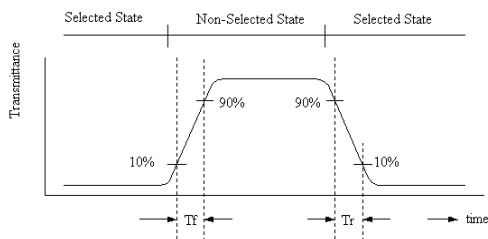

[Note 3] Definition of Viewing Angle :

[Note 4] Definition of Contrast Ratio :

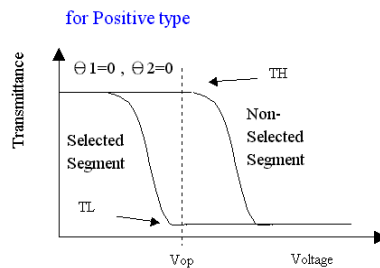
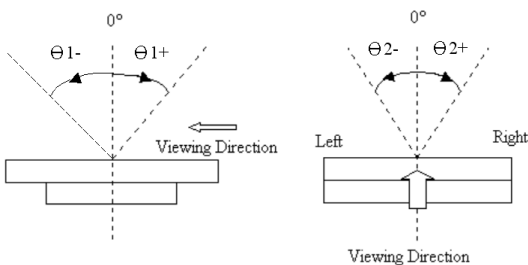

$$\text{Contrast Ratio} = \frac{TH}{TL}$$

[Note 5] Definition of measurement of Color Chromaticity and Brightness

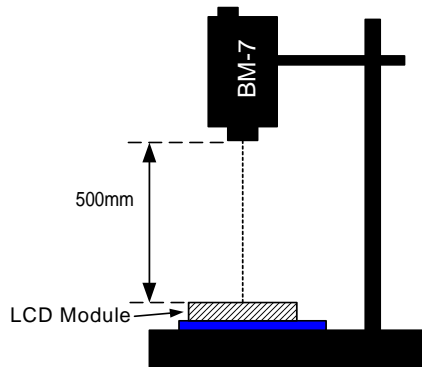

[Note 6] Definition of Brightness Uniformity

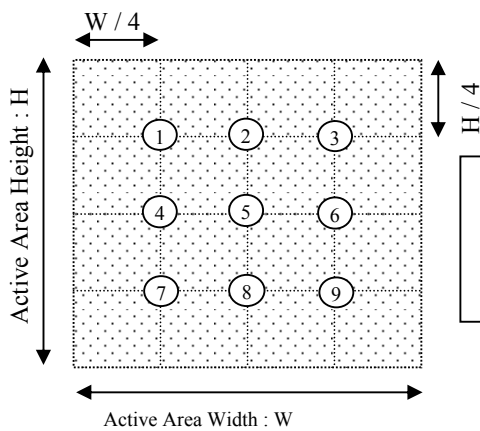

$$\text{Brightness Uniformity} = \frac{\text{Minimum Brightness of Point 1~9}}{\text{Maximum Brightness of Point 1~9}}$$

[Note 7] Definition of Measurement of Reflectance

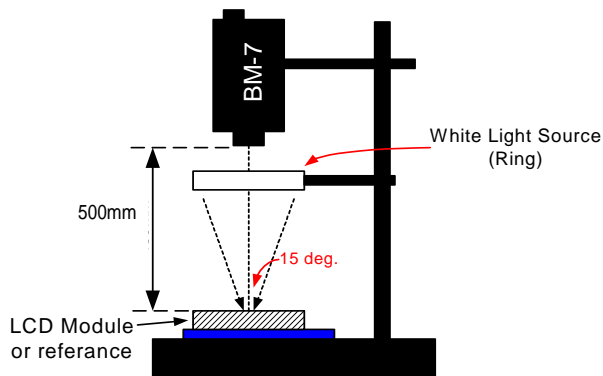

4. RELIABILITY :

Item No	Items	Condition	Note
1	High temperature operating	70 , 200 hours	1
2	Low temperature operating	-20 , 200 hours	1
3	High temperature storage	80 , 200 hours	1
4	Low temperature storage	-30 , 200 hours	1
5	High temperature & humidity storage	60 , 90%RH, 100 hours	2
6	Thermal Shock storage	-30 , 30min.<=> 80 , 30min. 10 Cycles	1
7	Vibration test	10 => 55 =>10 => 55 => 10 Hz , within 1 minute Amplitude : 1.5mm. 15 minutes for each Direction (X,Y,Z)	
8	Drop test	Packed, 100CM free fall, 6 sides, 1 corner, 3edges	
9	Life time	50,000 hours 25 , 60%RH , specification condition driving	

Note 1 : The product move into the room temperature for at least 2 hours with no condensation.

Note 2 : The product move into the room temperature for at least 24 hours with no condensation.

Note 3 : Please change the display picture (autorun) during operating mode. Avoid displaying static images to avoid image sticking , and the image sticking is accelerated by temperature.

* One single product test for only one item.

* Judgment after test : keep in room temperature for more than 2 hours.

- Current consumption < 2 times of initial value

- Contrast > 1/2 initial value

- Function : work normally

5. PRODUCT HANDLING AND APPLICATION

PRECAUTION FOR HANDLING LCM

The LCD module contains a C-MOS LSI. People who operate the LCM should wear ESD protection equipment to prevent ESD hurt on products.

Do not input any signal before power is turned on.

Do not take LCM from its packaging bag until it is assembled.

Peel off the LCM protective film slowly since static electricity may be generated.

Pay attention to the humidity of the work shop, 50~60%RH is satisfactory.

Use a non-leak iron for soldering LCM.

Do not touch the display surface or connection terminals area with bare hands. Smudges on the display surface reduce the insulation between terminals.

Cautions for soldering to LCM:

Condition for soldering I/O terminals:

Temperature at iron tip :350 ±15 .

Soldering time : 3~4sec./ terminals.

Type of solder : Eutectic solder(rosin flux filled).

PRECAUTION IN USE OF LCD

Do not contact or scratch the front surface and the contact pads of a LCD panel with hard materials such as metal or glass or with one's nail.

To clean the surface , wipe it gently with soft cloth dampened by alcohol.

Do not attempt to wiped off the contact pads.

Keep LCD panels away from direct sunlight , also avoid them in high-temperature & high humidity environment for a long period.

Do not drive LCD panels by DC voltage.

Do not expose LCD panels to organic solvent.

Liquid in LCD is hazardous substance. In case a contact with liquid crystal material is occurred, be sure to immediately wash such material away by soap and water.

The polarizer is easily damaged and should be handle with special care. Don't press or rub it with hard objects.

PRECAUTION FOR STORING AND USE OF LCM

To avoid degradation of the device , do not store the module under the conditions of direct sunlight , high temperature or high humidity . Keep the module in bags designed to prevent static electricity charging under low temperature / normal humidity conditions(avoid high temperature / high humidity and low temperature below 0)

Never use the LCD , LCM under 45 Hz , the liquid crystal will decomposition and cause permently damage on display !!

USING ON MEDICAL CARE , SAFETY OR HAZARDOUS APPLICATION OR SYSTEM

For the application in medical care, safety and hazardous products or systems, an authorization from URT is required. URT will not responsible for any damage or loss which caused by the products without any authorization given by URT.

This product is not allowed to be designed and used for military application and/or purpose.

The delivery of this product to the countries and/or regions where the embargoes are imposed by U.N. is prohibited.

The application and delivery of this product must comply with Strategic High-Tech Commodities (SHTC) export control and the sales to the embargoed and/or sanctioned countries or regions are strictly prohibited.

6. DATE CODE OF PRODUCTS

Date code will be shown on each product :

YY MM DD - XXXX

| | | |
Year Month Day - Production lots

Example: 121108 - 0003 ==> Year 2012, November,8th , Batch no.0003

Note : The lot no. attached on the packing box will be used for tracking once the part is too small to print the date code.

7. PACKING

Instruction of lot number:

LOT NO. : 0 0 0 8 3 5 2 5 (EX)

Date	01-1 st
	02-2 ^{ed}
Week	31-31 th
	1 — 6
Week of Month	1 — 5
Month	01-January
	02-February
	12-December
Year	00-2000
	01-2001

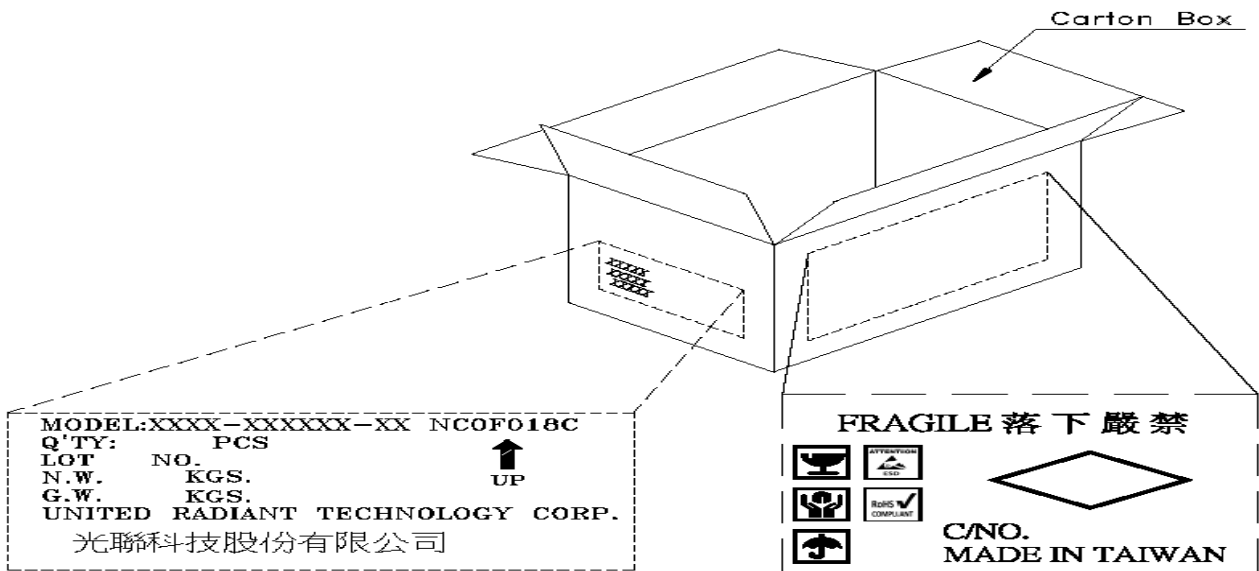

Packing tray must be stacked with alternated direction to each others.
 To tacks packing trays in same direction will cause product damaged.

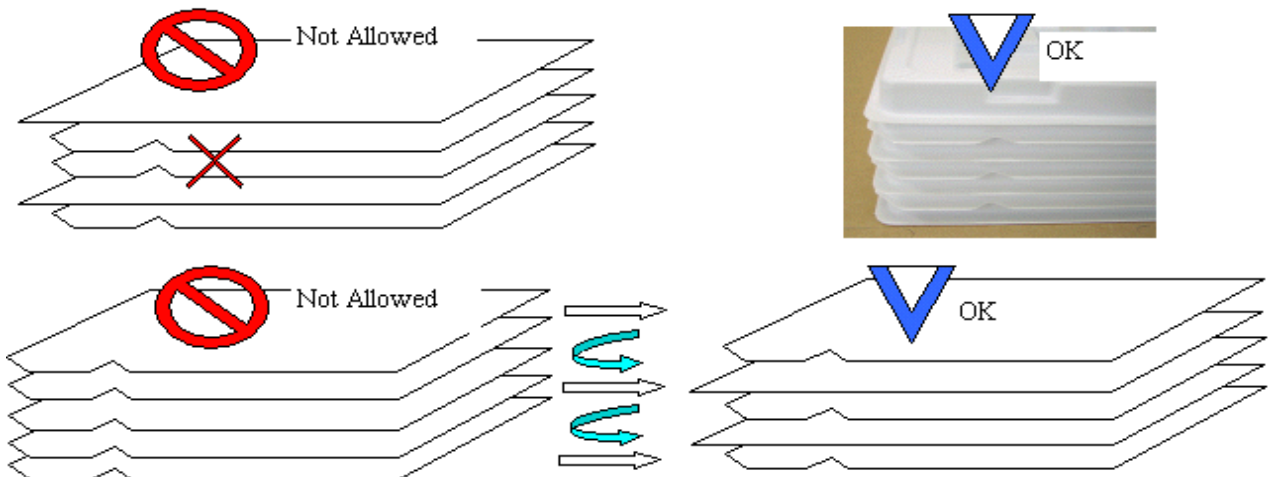

MODEL NO : UMSH-8065MD-17T(REVT) NOTE:

6 pcs / Tray
 7+1 Tray / Box
 4 Box / Carton
 168 pcs / Carton

(1) Be warned ,the direction of the tray has to turn it by 180 degree before stack it up. Otherwise, it will be packager's responsibility!!
 (2) Safe Stack : 5 cartons only

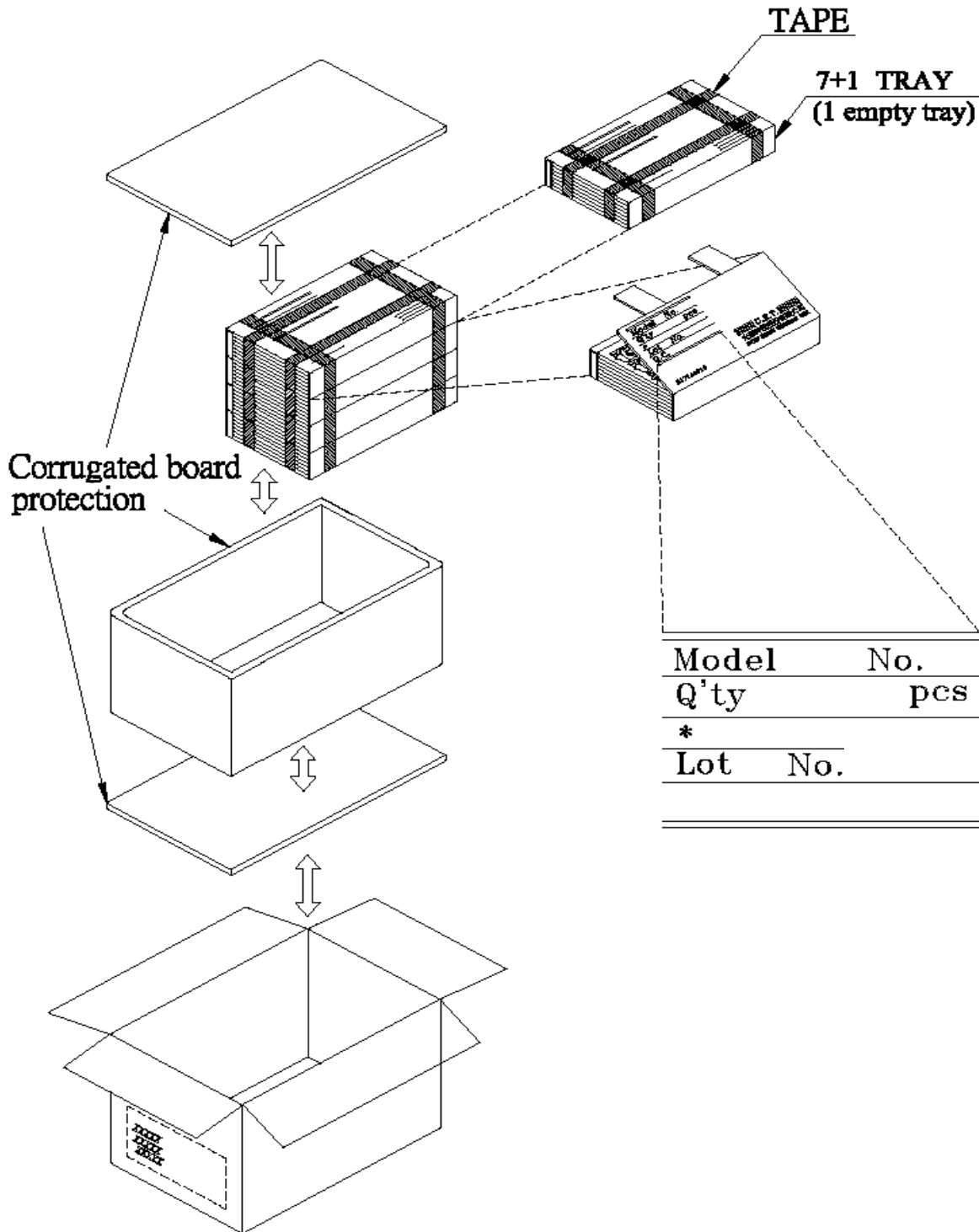

8. INSPECTION STANDARD

8.1. QUALITY :

THE QUALITY OF GOODS SUPPLIED TO PURCHASER SHALL COME UP TO THE FOLLOWING STANDARD.

8.1.1. THE METHOD OF PRESERVING GOODS

AFTER DELIVERY OF GOODS FROM U.R.T. TO PURCHASER. PURCHASER SHALL CONTROL THE LCM AT -10 40 ,AND IT MIGHT BE DESIRABLE TO KEEP AT THE NORMAL ROOM TEMPERATURE AND HUMIDITY UNTIL INCOMING INSPECTION OR THROWING INTO PROCESS LINE.

8.1.2. INCOMING INSPECTION

(A) THE METHOD OF INSPECTION

IF PURCHASER MAKE AN INCOMING INSPECTION , A SAMPLING PLAN SHALL BE APPLIED ON THE CONDITION THAT QUALITY OF ONE DELIVERY SHALL BE REGARDED AS ONE LOT.

(B) THE STANDARD OF QUALITY

ISO-2859-1 (SAME AS MIL-STD-105E) , LEVEL SINGLE PLAN.

CLASS	AQL(%)
CRITICAL	0.4 %
MAJOR	0.65 %
MINOR	1.5 %
TOTAL	1.5 %

EVERY ITEM SHALL BE INSPECTED ACCORDING TO THE CLASS.

(C) MEASURE

IF AS THE RESULT OF ABOVE RECEIVING INSPECTION , A LOT OUT IS DISCOVERED.

PURCHASER SHALL BE INFORM SELLER OF IT WITHIN SEVEN DAYS. BUT FIRST SHIPMENT WITHIN FOURTEEN DAYS.

8.1.3. WARRANTY POLICY

U.R.T. WILL PROVIDE ONE-YEAR WARRANTY FOR THE PRODUCTS ONLY IF UNDER SPECIFICATION OPERATING CONDITIONS. U.R.T. WILL REPLACE NEW PRODUCTS FOR THESE DEFECT PRODUCT; WHICH UNDER WARRANTY PERIOD AND BELONG TO THE RESPONSIBILITY OF U.R.T.

8.2. CHECKING CONDITION

8.2.1. CHECKING DIRECTION SHALL BE IN THE 45 DEGREE AREA TO FACE THE SAMPLE.

8.2.2. CHECKER SHALL SEE OVER 300±25 mm. WITH BARE EYES FAR FROM SAMPLE AND USING 2 PCS. OF 20W FLUORESCENT LAMP.

8.3. INSPECTION PLAN :

CLASS	ITEM	JUDGEMENT	CLASS
PACKING & INDICATE	1. OUTSIDE AND INSIDE PACKAGE	"MODEL NO." , "LOT NO." AND "QUANTITY" SHOULD INDICATE ON THE PACKAGE.	Minor
	2. MODEL MIXED AND QUANTITY	OTHER MODEL MIXED.....REJECTED QUANTITY SHORT OR OVER.....REJECTED	Critical
	3. PRODUCT INDICATION	"MODEL NO." SHOULD INDICATE ON THE PRODUCT	Major
ASSEMBLY	4. DIMENSION, LCD GLASS SCRATCH AND SCRIBE DEFECT.	ACCORDING TO SPECIFICATION OR DRAWING.	Major
APPEARANCE	5. VIEWING AREA	POLARIZER EDGE OR LCD'S SEALING LINE IS VISABLE IN THE VIEWING AREAREJECTED	Minor
	6. BLEMISH, BLACK SPOT, WHITE SPOT IN THE LCD AND LCD GLASS CRACKS	ACCORDING TO STANDARD OF VISUAL INSPECTION (INSIDE VIEWING AREA)	Minor
	7. BLEMISH, BLACK SPOT WHITE SPOT AND SCRATCH ON THE POLARIZER	ACCORDING TO STANDARD OF VISUAL INSPECTION (INSIDE VIEWING AREA)	Minor
	8. BUBBLE IN POLARIZER	ACCORDING TO STANDARD OF VISUAL INSPECTION (INSIDE VIEWING AREA)	Minor
	9. LCD'S RAINBOW COLOR	STRONG DEVIATION COLOR (OR NEWTON RING) OF LCD.....REJECTED. OR ACCORDING TO LIMITED SAMPLE (IF NEEDED, AND INSIDE VIEWING AREA)	Minor
ELECTRICAL	10. ELECTRICAL AND OPTICAL CHARACTERISTICS (CONTRAST, VOP, CHROMATICITY ... ETC)	ACCORDING TO SPECIFICATION OR DRAWING . (INSIDE VIEWING AREA)	Critical
	11. MISSING LINE	MISSING DOT, LINE, CHARACTERREJECTED	Critical
	12. SHORT CIRCUIT, WRONG PATTERN DISPLAY	NON DISPLAY, WRONG PATTERN DISPLAY, CURRENT CONSUMPTION OUT OF SPECIFICATION..... REJECTED	Critical
	13. PIN HOLE, PATTERN DEFORMITY	ACCORDING TO STANDARD OF VISUAL INSPECTION	Minor

8.4. STANDARD OF VISUAL INSPECTION

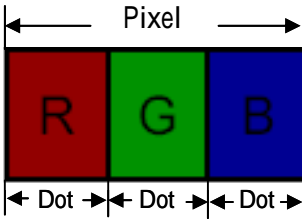
NO.	CLASS	ITEM	JUDGEMENT																				
8.4.1	MINOR	BLACK AND WHITE SPOT FOREIGN MATERIEL DUST IN THE CELL BLEMISH SCRATCH	<p>(A) ROUND TYPE: unit : mm.</p> <table border="1"> <thead> <tr> <th>DIAMETER (mm.)</th> <th>ACCEPTABLE Q'TY</th> </tr> </thead> <tbody> <tr> <td>0.1</td> <td>DISREGARD</td> </tr> <tr> <td>0.1 < 0.25</td> <td>3</td> </tr> <tr> <td>0.25 <</td> <td>0</td> </tr> </tbody> </table> <p>NOTE: $=(\text{LENGTH}+\text{WIDTH})/2$</p> <p>(B) LINEAR TYPE: unit : mm.</p> <table border="1"> <thead> <tr> <th>LENGTH</th> <th>WIDTH</th> <th>ACCEPTABLE Q'TY</th> </tr> </thead> <tbody> <tr> <td>-----</td> <td>W 0.03</td> <td>DISREGARD</td> </tr> <tr> <td>L 5.0</td> <td>0.03 < W 0.07</td> <td>3</td> </tr> <tr> <td>-----</td> <td>0.07 < W</td> <td>FOLLOW ROUND TYPE</td> </tr> </tbody> </table>	DIAMETER (mm.)	ACCEPTABLE Q'TY	0.1	DISREGARD	0.1 < 0.25	3	0.25 <	0	LENGTH	WIDTH	ACCEPTABLE Q'TY	-----	W 0.03	DISREGARD	L 5.0	0.03 < W 0.07	3	-----	0.07 < W	FOLLOW ROUND TYPE
DIAMETER (mm.)	ACCEPTABLE Q'TY																						
0.1	DISREGARD																						
0.1 < 0.25	3																						
0.25 <	0																						
LENGTH	WIDTH	ACCEPTABLE Q'TY																					
-----	W 0.03	DISREGARD																					
L 5.0	0.03 < W 0.07	3																					
-----	0.07 < W	FOLLOW ROUND TYPE																					
8.4.2	MINOR	BUBBLE IN POLARIZER DENT ON POLARIZER	<p style="text-align: right;">unit : mm.</p> <table border="1"> <thead> <tr> <th>DIAMETER</th> <th>ACCEPTABLE Q'TY</th> </tr> </thead> <tbody> <tr> <td>0.2</td> <td>DISREGARD</td> </tr> <tr> <td>0.2 < 0.5</td> <td>2</td> </tr> <tr> <td>0.5 <</td> <td>0</td> </tr> </tbody> </table>	DIAMETER	ACCEPTABLE Q'TY	0.2	DISREGARD	0.2 < 0.5	2	0.5 <	0												
DIAMETER	ACCEPTABLE Q'TY																						
0.2	DISREGARD																						
0.2 < 0.5	2																						
0.5 <	0																						
8.4.3	MINOR	Dot Defect	<table border="1"> <thead> <tr> <th>Items</th> <th>ACC. Q'TY</th> </tr> </thead> <tbody> <tr> <td>Bright dot</td> <td>N 4</td> </tr> <tr> <td>Dark dot</td> <td>N 4</td> </tr> </tbody> </table> <p>Pixel Define :</p>  <p>Note 1: The definition of dot: The size of a defective dot over 1/2 of whole dot is regarded as one defective dot.</p> <p>Note 2: Bright dot: Dots appear bright and unchanged in size in which LCD panel is displaying under black pattern.</p> <p>Note 3: Dark dot: Dots appear dark and unchanged in size in which LCD panel is displaying under pure red, green, blue pattern.</p>	Items	ACC. Q'TY	Bright dot	N 4	Dark dot	N 4														
Items	ACC. Q'TY																						
Bright dot	N 4																						
Dark dot	N 4																						

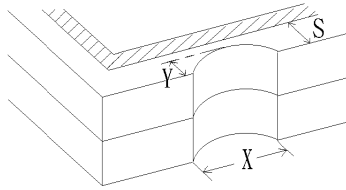
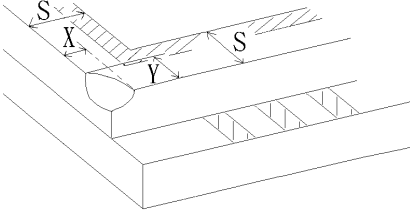
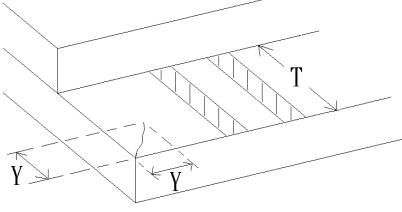
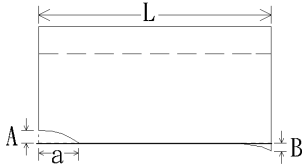
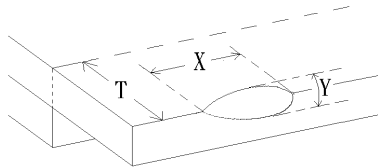
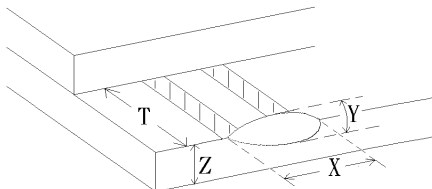
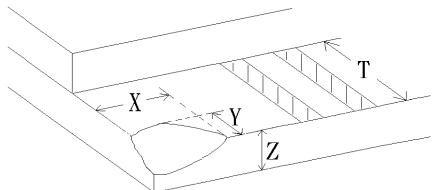
NO.	CLASS	ITEM	JUDGEMENT
8.4.4	MINOR	CHIPPING	 $Y > S$ REJ.
8.4.5	MINOR	CHIPPING	 $X \text{ or } Y > S$ REJ.
8.4.6	MAJOR	GLASS CRACK	 $Y > (1/2) T$ REJ.
8.4.7	MAJOR	SCRIBE DEFECT	 <ol style="list-style-type: none"> $a > L/3$, $A > 1.5\text{mm}$. REJ. B : ACCORDING TO DIMENSION
8.4.8	MINOR	CHIPPING (ON THE TERMINAL AREA)	 $= (x+y)/2 > 2.5 \text{ mm}$ REJ.
8.4.9	MINOR	CHIPPING (ON THE TERMINAL SURFACE)	 $Y > (1/3) T$ REJ.
8.4.10	MINOR	CHIPPING	 $Y > T$ REJ.

8.5 INSPECTION STANDARD OF TOUCH PANEL

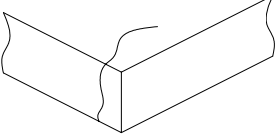
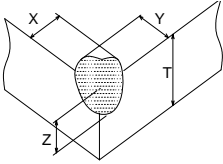
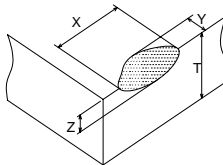
NO.	CLASS	ITEMS	JUDGEMENT						
8.5.1	MAJOR	Touch Panel Crack	 <p>Reject</p>						
8.5.2	MINOR	Touch Panel Chipping	<div style="display: flex; align-items: center;">  <table border="1" style="margin-left: 20px;"> <tr> <td>Not CNC Products</td> <td>X 2mm, Y 2mm, Z < 1/2T</td> <td>Accept</td> </tr> <tr> <td>CNC Products</td> <td>For CNC Outline Dimension</td> <td>Accept</td> </tr> </table> </div>	Not CNC Products	X 2mm, Y 2mm, Z < 1/2T	Accept	CNC Products	For CNC Outline Dimension	Accept
			Not CNC Products	X 2mm, Y 2mm, Z < 1/2T	Accept				
CNC Products	For CNC Outline Dimension	Accept							
<div style="display: flex; align-items: center;">  <table border="1" style="margin-left: 20px;"> <tr> <td>Not CNC Products</td> <td>X 3mm, Y 3mm, Z < 1/2T</td> <td>Accept</td> </tr> <tr> <td>CNC Products</td> <td>For CNC Outline Dimension</td> <td>Accept</td> </tr> </table> </div>	Not CNC Products	X 3mm, Y 3mm, Z < 1/2T	Accept	CNC Products	For CNC Outline Dimension	Accept			
Not CNC Products	X 3mm, Y 3mm, Z < 1/2T	Accept							
CNC Products	For CNC Outline Dimension	Accept							
8.5.3	MINOR	Scratch Dust and Foreign materiel (Linear Type)	W 0.05, L 10mm Accept						
			0.05mm < W 0.07mm ; L 5.0mm Accept 3 ea Max.						
			W > 0.07mm Reject						
8.5.4	MINOR	Scratch Dust and Foreign materiel (Round Type : =(Length+Width)/2)	0.25mm Accept						
			0.25mm < 0.35mm Accept 5 ea Max.						
			> 0.35mm Reject						
8.5.5	MINOR	Touch Panel Dent / Fish Eyes	0.35mm Accept						
			0.35mm < 1.0mm Distance > 5.0mm Accept 3 ea Max.						
			> 1.0mm Reject						
8.5.6	MINOR	Touch Panel Air Bubble	0.2mm Accept						
			0.2mm < 0.5mm Accept 3 ea Max.						
			> 0.5mm Reject						
8.5.7	MINOR	Touch Panel Printing area Scratch	W 0.03, L 10mm Accept						
			0.03mm < W 0.05mm, L 5mm Accept 3 ea Max.						
			W > 0.05mm or L > 5mm (W > 0.05 Follow 8.5.4 Round type) Reject						
8.5.8	MINOR	Touch Panel White Haze Mark / Dust	Can not be removed Reject						