

OPERATING INSTRUCTIONS

**Manufacturer:**

Ripley® Miller

Product Name:

Ripley® Miller ACS-2 Heavy-Duty & Armored Cable Slitter (4 mm - 10 mm)

Manufacturer Part Number:

ACS-2

▶ [Click here for more details on the Ripley® Miller ACS-2 Heavy-Duty & Armored Cable Slitter \(4 mm - 10 mm\)](#)

ACS ARMORED CABLE SLITTER

Instruction Sheet

U.S. Patent No. D505,056S

Warning! This tool should not be used on live electrical circuits. It is not protected against electrical shock! Always use OSHA/ANSI or other industry approved eye protection when using tools. This tool is not to be used for purposes other than intended. Read carefully and understand instructions before using this tool.

The ACS Tools are designed to work on jacketed or jacketed and armored multi-fiber cable. Their main purpose is to gain midspan access to fiber optic conductors by slitting the outer jacket or jacket and armor on the above cables. The tools are designed with a precision adjustable blade to avoid damage to the fibers. The cable outer diameter range is noted below for each model. The blade can be set up to .215"(5.5mm) deep for each model.

Model	Cable Diameter Range	Guide Wheel Color
ACS	5/16" - 1-1/8" (8mm - 28.6mm)	Gold
ACS-2	5/32" - 25/64"(4mm - 10mm)	Red

OPERATING INSTRUCTIONS:**A. Determine cable construction.**

1. Multi-fiber cable construction may have a strength member that is internal and adjacent to the fibers or external and adjacent to the armor and jacket. **To avoid tool damage, first determine the cable construction.**

B. Set the blade.

1. The tool will be shipped with the slitting blade retracted. With a sample piece of cable as a guide, the cutting blade depth setting can be made. The bottom of the thumb knob "A" has a slotted set screw that adjusts the blade height as it is turned. The bottom of the thumb knob also has 10 graduations. Each full turn of the adjusting screw amounts to .042" of blade travel. In turn, each graduation equals .0042" of blade adjustment. When the blade is set properly, the tool will create a "zipper" sound on armored cable. Avoid setting blade too deep so to protect underlying layers.

C. Tool operation. Follow steps 1-6 for cable with internal or external strength member. (LONGITUDINAL CUT)

1. Loosen black thumb knob "A" completely, rotate the blade assembly to the longitudinal position. (the picture shows blade set for radial cut)

2. Place cable in tool opening. Adjust the roller with yellow thumb knob "B" for a snug fit.

3. Tighten black thumb knob down to position blade for longitudinal cuts.

4. Pull the tool down the length of cable to be stripped. If working on an external strength member cable with a "lay", the tool will follow the hardened strength members and slightly spiral down the cable. Allow the tool to follow the strength member.

5. Loosen black thumb knob and rotate the tool 180° about the cable. Re-tighten black knob and perform second longitudinal cut.

6. The cable is now ready to be split open with pliers or screwdriver and trimmed.

Stop at step 6 for cables with external strength members.

The following additional steps apply only to cable with internal strength members. (RADIAL CUT)

7. A radial slitting operation can be performed near the midpoint of the longitudinal cut. Slide tool to desired position. Loosen black thumb knob "A" completely, swing blade assembly 90° to the radial setting, re-tighten black knob to set the blade depth.

8. Rotate tool about the cable to perform a ringing cut.

9. The cable can now be split open, "banana peeled", and trimmed.

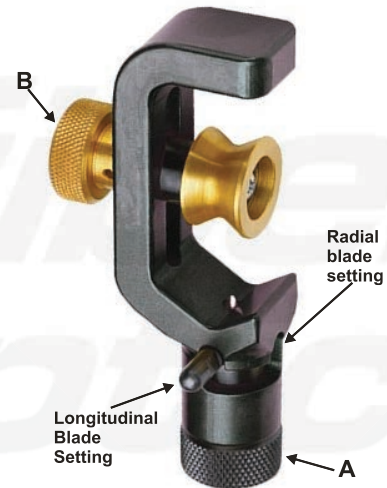

Contact the professionals at Fiber Optic Center for a quote or to get more details.

focenter.com • 508-992-6464 | (800) 473-4237 • sales@focenter.com

23 Centre Street • New Bedford, MA 02740 USA

Product specifications and data are subject to change without notice. FOC last update 12/29/2025.