

38'-3"

31'-6"

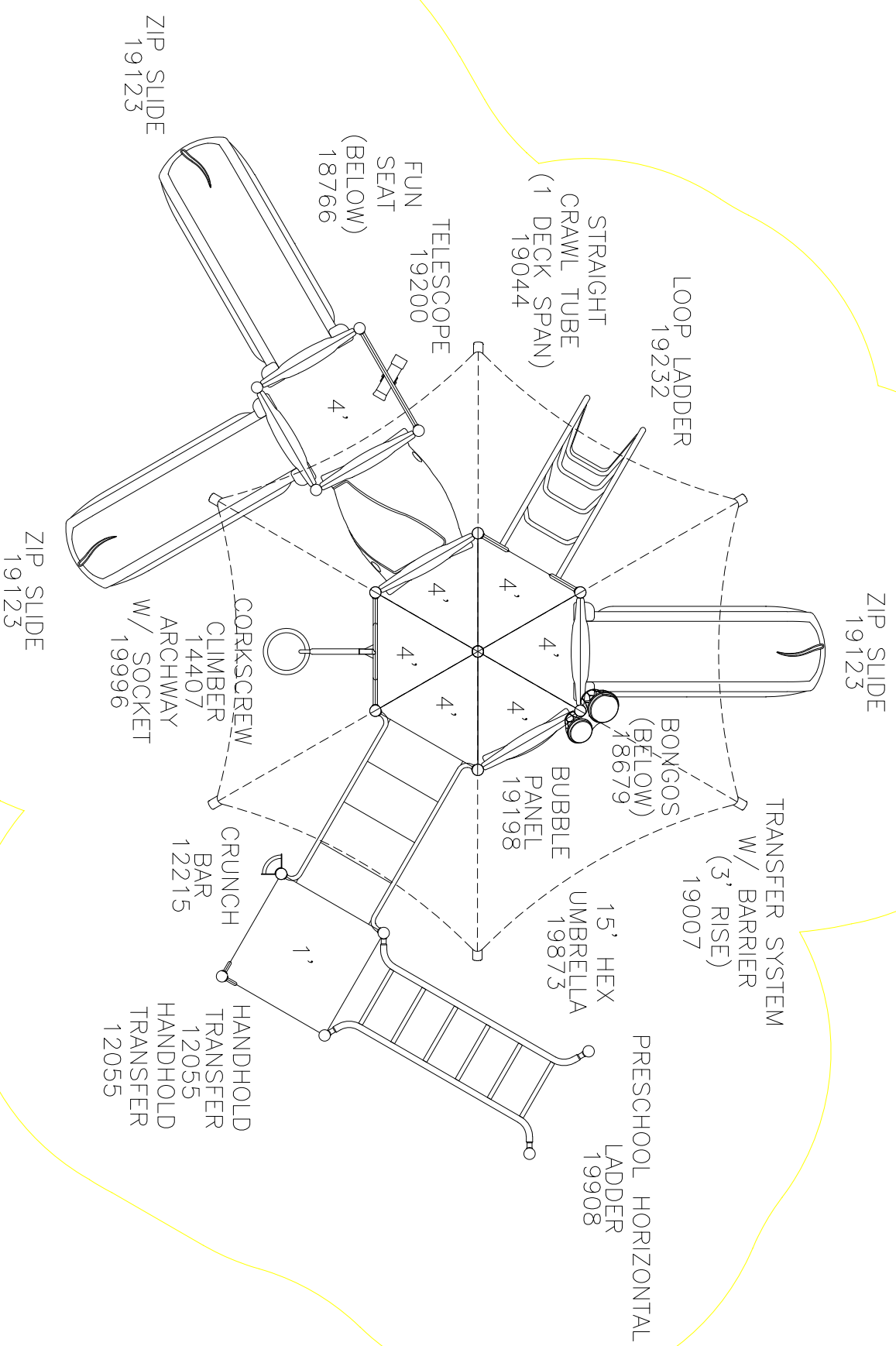

This Unit includes play events and routes or travel specifically designed for special needs users. It is the opinion of the manufacturer that these play events and routes of travel conform to the accessibility requirements of the ADA (Americans with Disabilities Act)

Total Elevated Play Components	9	
Total Elevated Play Components Accessible By Ramp	0	Required
Total Elevated Components Accessible By Transfer	9	Required
Total Elevated Ground Level Components Shown	3	Required
Total Different Types Of Ground Level Components	3	Required

**IMPORTANT:** Soft resilient surfacing should be placed in the use zones of all equipment, as specified for each type of equipment, and at depths to meet the critical fall heights as specified by the U.S. consumer Product Safety Commission, ASTM standard F 1487 and Canadian Standard CAN/CSA-Z-614



A PLAYCORE Company

150 PlayCore Drive SE  
Fort Payne, AL 35967  
www.gametime.com



**NEW BRUNSWICK 2-5 WITH SHADE**  
**PT24052**

Representative

This play equipment is recommended for children ages **2-5**

Minimum Area Required:

Scale: 1" = 5'-0"

This drawing can be scaled only when in an 8 1/2" x 11" format

Drawn By:

Date:

Drawing Name: