

35W

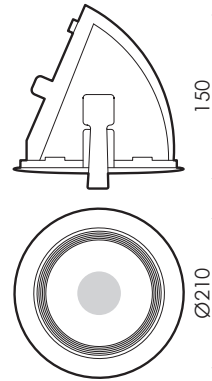

50W

	Aislamiento eléctrico	CII
	Índice de estanqueidad	IP44
Hz	Frecuencia	50-60Hz
	Tensión	220-240V

PRECAUCIONES:

- Desconecte la corriente antes de instalar el producto.
- Mantenga el producto fuera del alcance de los niños.
- No sumerja este producto en agua ni lo manipule con las manos mojadas.
- No usar guantes ni cualquier material plástico.
- No golpee el producto.
- No instale el producto donde haya fuentes de calor o concentraciones de humedad.
- No manipule el producto mientras se encuentre en funcionamiento y déjelo enfriar antes de tocarlo con las manos.
- La pantalla no debe ser cubierta por material aislante térmico en ningún caso.
- Si el producto se encuentra dañado sustitúyalo inmediatamente por uno nuevo.
- Esta luminaria contiene componentes sensibles a la electricidad estática y una descarga sobre ella podría destruir o dañar sus componentes.
- No válido para utilización en baños.
- Solo para uso interior.
- LED no reemplazable.

AVISO

- Antes de comenzar la instalación de éste producto, por favor, lea atentamente las instrucciones y guárdelas en un sitio seguro.
- La instalación debe realizarla personal cualificado.
- La inadecuada manipulación de los componentes o de la propia luminaria podría dañar el correcto funcionamiento de este producto, quedando anulada la garantía del fabricante.
- Queda anulada la garantía del fabricante: si la instalación no se realiza según lo indicado en el REBT 2002.
- Es de obligado cumplimiento la aplicación de ITC BT09-4 del rebt (instalación de protectores de sobretensiones en líneas y luminarias) para instalaciones industriales y de alumbrado público. La garantía no cubre daños producidos por sobretensiones en luminarias sin protectores de sobretensiones.

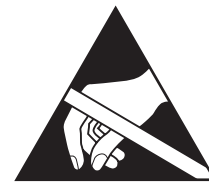

ATENCIÓN!!! RESPETAR LAS PRECAUCIONES DE MANIPULACIÓN DE LOS COMPONENTES SENSIBLES A DESCARGAS ELECTROSTÁTICAS (LED).



FIG.1

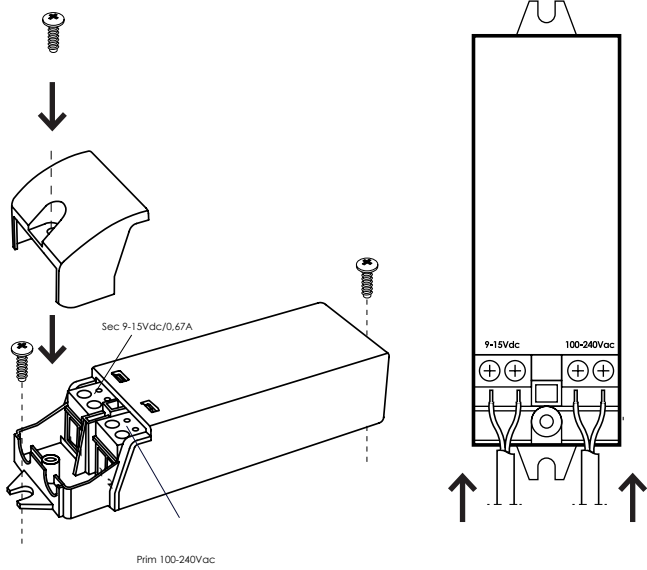

CONEXIONADO EMERGENCIA

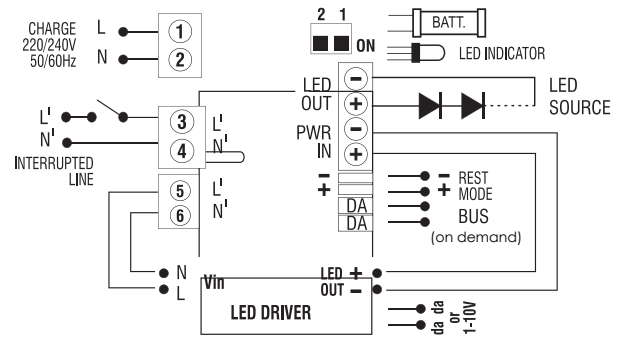

CONEXIONADO REGULACIÓN DALI

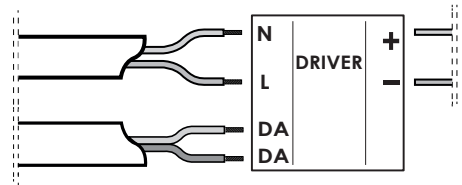

CONEXIONADO REGULACIÓN 1-10V

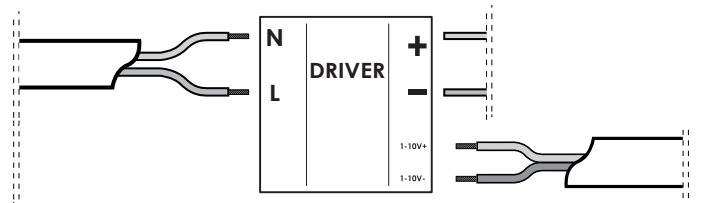

FIG.2

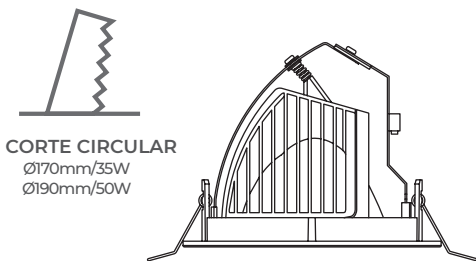
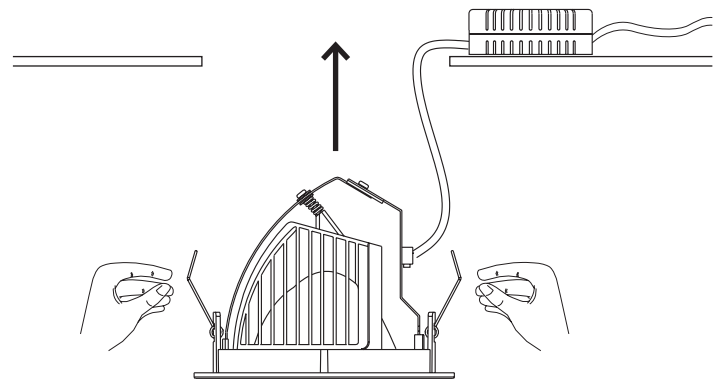
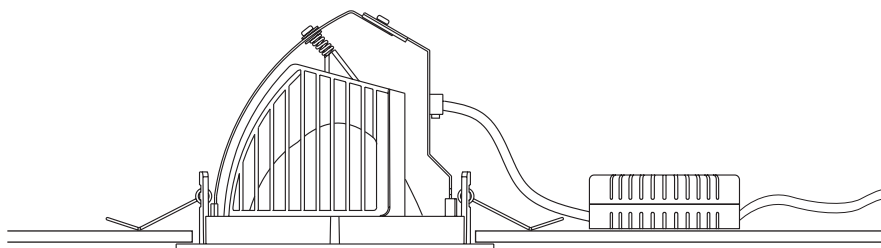
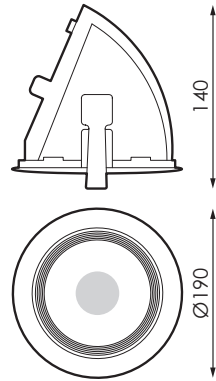

FIG.3



POSICIÓN DEL DRIVER





35W

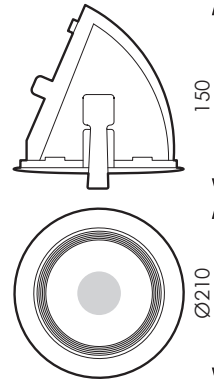

50W

	Electrical isolation	CII
	Sealing rating	IP44
Hz	Frequency	50-60Hz
	Voltage	220-240V

PRECAUTIONS:

- Switch off the power before installing the product.
- Keep the product out of the reach of children.
- Do not immerse this product in water or handle with wet hands.
- Do not use gloves or any plastic material.
- Do not hit the product.
- Do not install the product where there are sources of heat or concentrations of moisture.
- Do not handle the product while it is in operation and allow it to cool before touching it with your hands.
- The screen must not be covered by thermal insulation material in any case.
- If the product is damaged, replace it immediately with a new one.
- This luminaire contains components sensitive to static electricity and a discharge on it could destroy or damage its components.
- Not valid for use in bathrooms.
- For indoor use only.
- Non-replaceable LED

WARNING

- Before installing this product, please read the instructions carefully and store them in a safe place.
- The installation should be carried out by trained staff.
- Incorrect handling of the parts or the light fixture itself may impair the proper performance of this product. In this case, the manufacturer guarantee shall be deemed void.
- The manufacturer guarantee shall be deemed void: if the installation is not performed in accordance with the spanish low voltage electrotechnical regulation 2002 (REBT 2002).
- The application of ITC BT09-4of rebt (installation of line and light fixture surge protectors) is essential for industrial and public lighting installations. The guarantee does not cover against damages caused by surges in light fixtures without surge protectors installed.

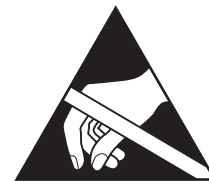

ATTENTION!!! OBSERVE PRECAUTIONS FOR HANDLING ELECTROSTATIC SENSITIVE DEVICES.



FIG.1

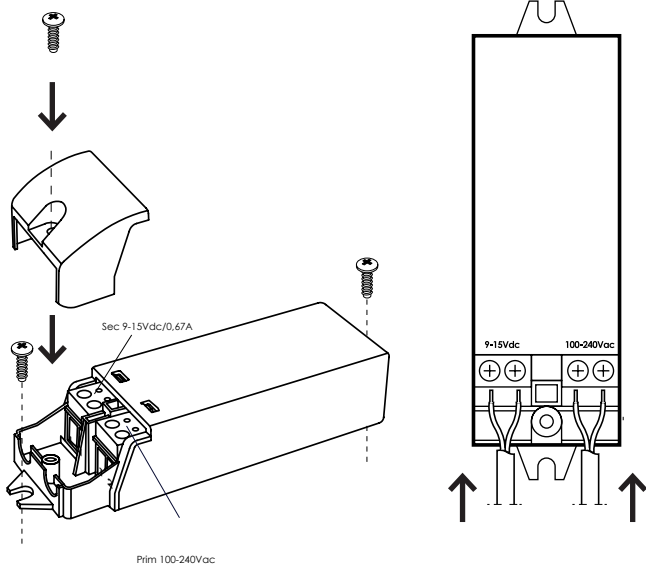

EMERGENCY CONNECTION

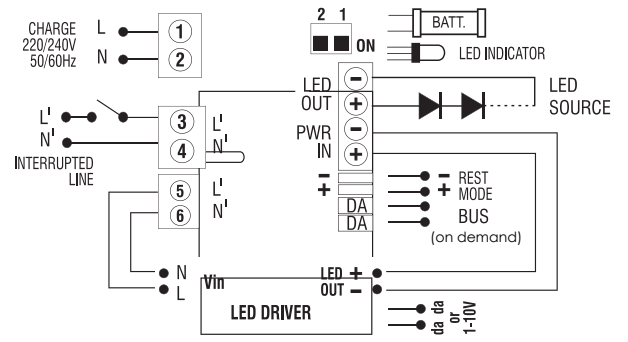

DALI REGULATION CONEXION

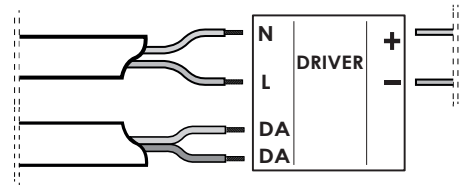

1-10V REGULATION CONEXION

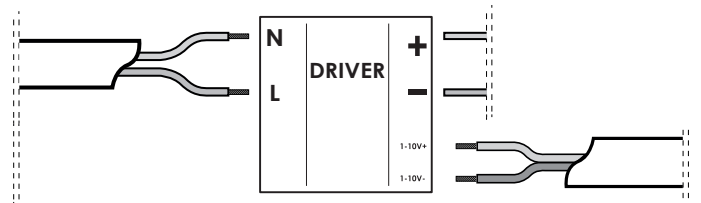
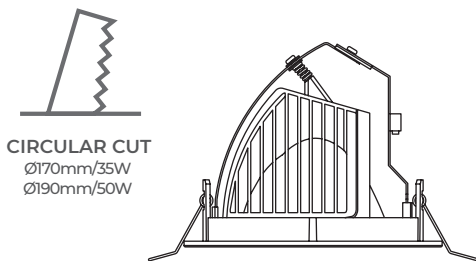

FIG.2



DRIVER POSITION

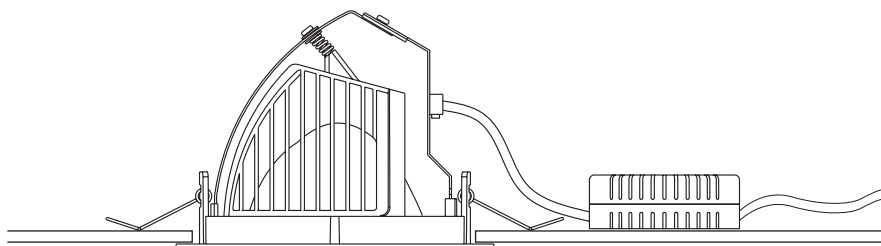
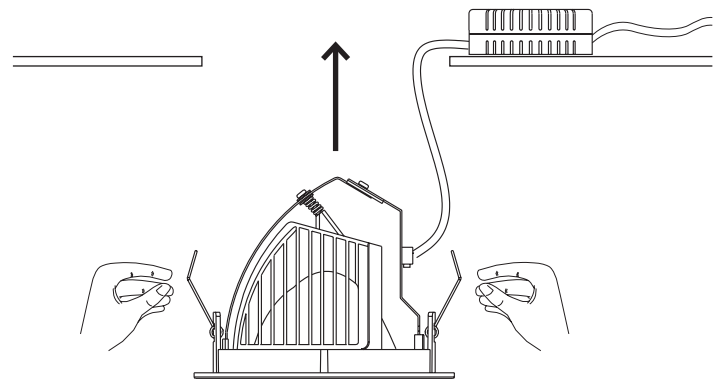
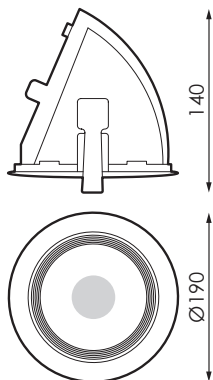
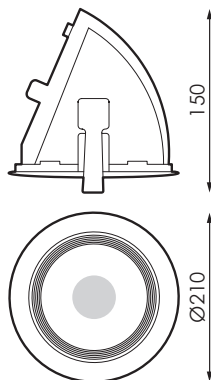

FIG.3





35W



50W

	Isolation électrique	CII
	Indice d'étanchéité	IP44
Hz	Fréquence	50-60Hz
	Tension	220-240V

PRÉCAUTIONS:

- Couper l'alimentation avant d'installer le produit.
- Tenir le produit hors de portée des enfants.
- Ne pas immerger ce produit dans l'eau ou le manipuler avec les mains mouillées.
- Ne pas utiliser de gants, ni de matériau plastique.
- Ne pas cogner le produit.
- Ne pas installer le produit dans un endroit où il y a des sources de chaleur ou des concentrations d'humidité.
- Ne pas manipuler le produit pendant son fonctionnement et le laisser refroidir avant de le toucher avec vos mains.
- Le produit ne doit en aucun cas être recouvert d'un matériau d'isolation thermique.
- Si le produit est endommagé, le remplacer immédiatement par un nouveau.
- Ce produit contient des composants sensibles à l'électricité statique et une décharge électrique pourrait détruire ou endommager les composants.
- Invalide pour utilisation dans les salles de bains.
- Utilisation intérieure uniquement.
- LED non remplaçable.

AVERTISSEMENT

- Avant de commencer l'installation de ce produit, veuillez lire attentivement les instructions et les conserver dans un endroit sûr.
- L'installation doit être effectuée par du personnel qualifié.
- Une manipulation inappropriée des composants ou du luminaire pourrait nuire au bon fonctionnement de ce produit, annulant ainsi la garantie du fabricant.
- La garantie du fabricant est annulée : si l'installation n'est pas effectuée conformément au règlement électrotechnique pour basse tension espagnol (rebt 2002).

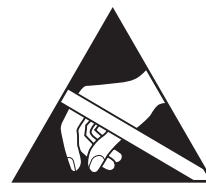

RESPECTER LES PRÉCAUTIONS DE MANIPULATION DES COMPOSANTS SENSIBLES AUX DÉCHARGES ÉLECTROSTATIQUES (LED).

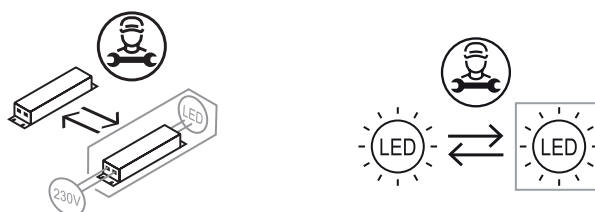
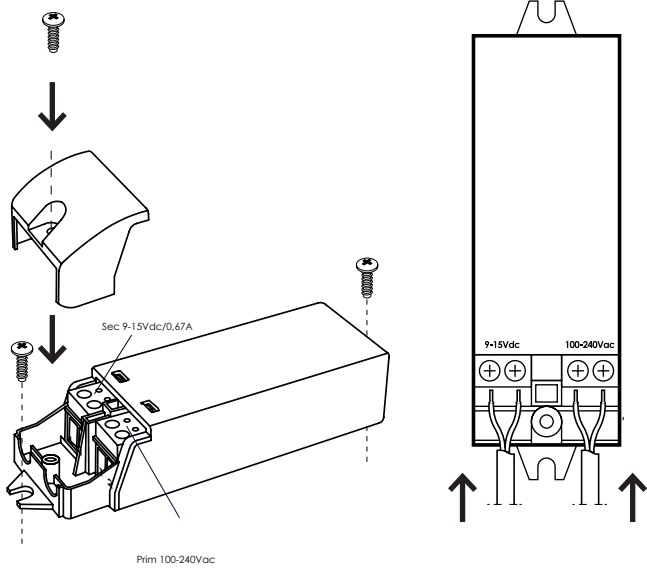
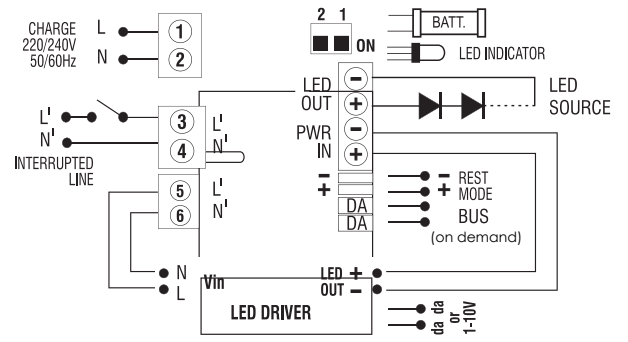

FIG.1



RACCORDEMENT URGENCE



RACCORDEMENT RÉGLAGE DALI

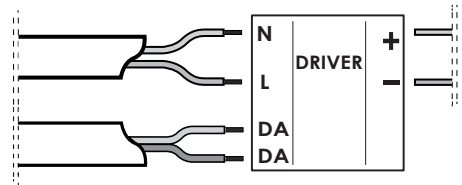

RACCORDEMENT RÉGLAGE 1-10V

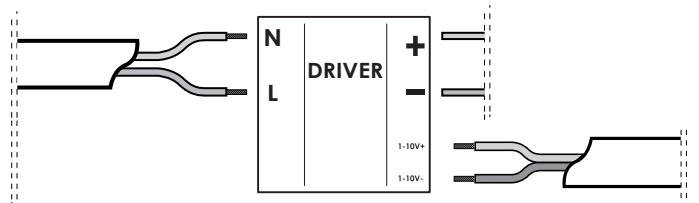

FIG.2

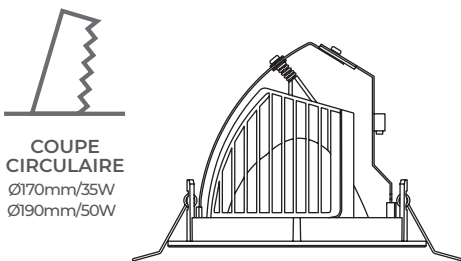
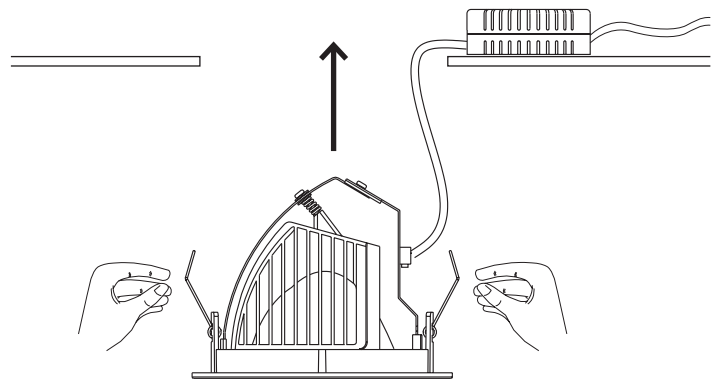
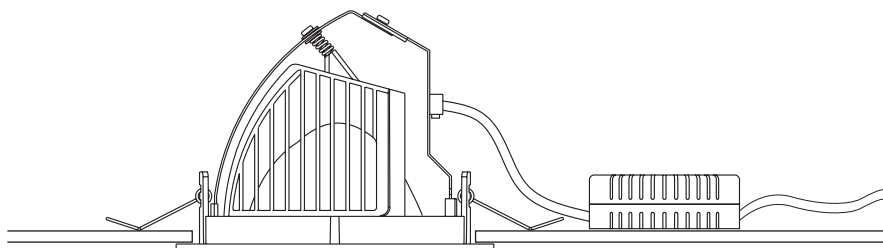
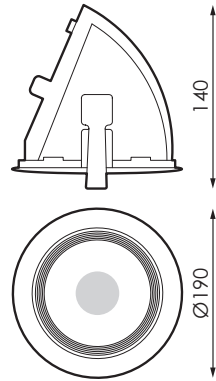

FIG.3



POSITION DU DRIVER





35W

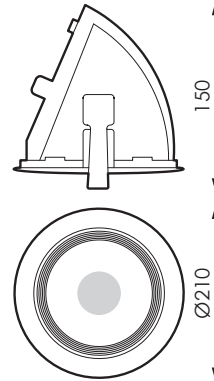

50W

	Isolamento elétrico	CII
	Índice de estanquicidade	IP44
Hz	Frequência	50-60Hz
	Tensões	220-240V

PRÉCAUTIONS:

- Desligar a corrente antes de instalar o produto.
- Manter o produto fora do alcance das crianças.
- Não mergulhar este produto em água, nem o manipular com as mãos molhadas.
- Não usar luvas nem qualquer material plástico.
- Não golpear o produto.
- Não instalar o produto onde houver fontes de calor ou concentrações de humidade.
- Não manipular o produto enquanto este se encontrar em funcionamento e deixar arrefecer antes de tocar com as mãos.
- O produto nunca deverá ser coberto por material isolador térmico.
- Se o produto se encontrar danificado, substituir imediatamente por um novo.
- Este produto contém componentes sensíveis à eletricidade estática e uma descarga sobre o mesmo poderia destruir ou danificar os seus componentes.
- Não apto para utilização em casas de banho.
- Apenas para uso interior.
- LED não substituível.

AVISO

- Antes de começar a instalação deste produto, por favor leia atentamente as instruções e guarde-as num lugar seguro.
- A instalação deve ser realizada por pessoal qualificado.
- A manipulação imprópria dos componentes ou da própria luminária poderá prejudicar o funcionamento correto deste produto, ficando anulada a garantia do fabricante.
- Fica anulada a garantia do fabricante: se a instalação não se realizar conforme indicado no rebt 2002.



RESPEITAR AS PRECAUÇÕES DE MANIPULAÇÃO DOS COMPONENTES SENSÍVEIS A DESCARGAS ELETROSTÁTICAS (LED).

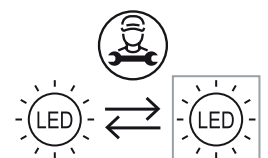
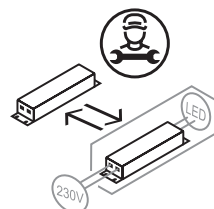
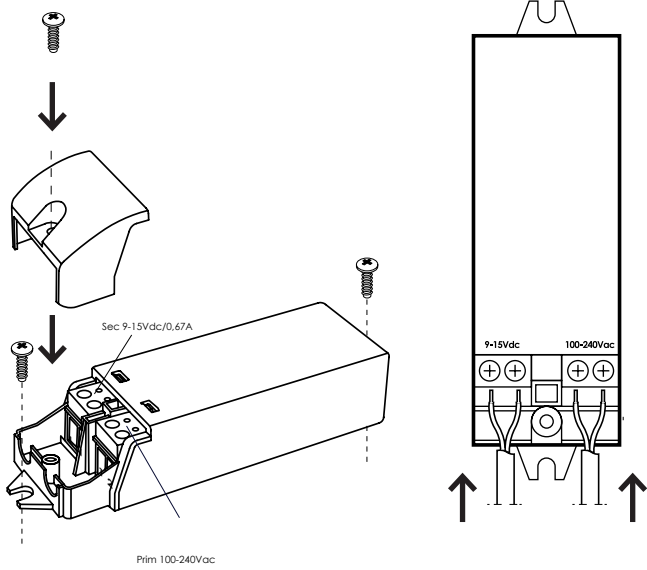
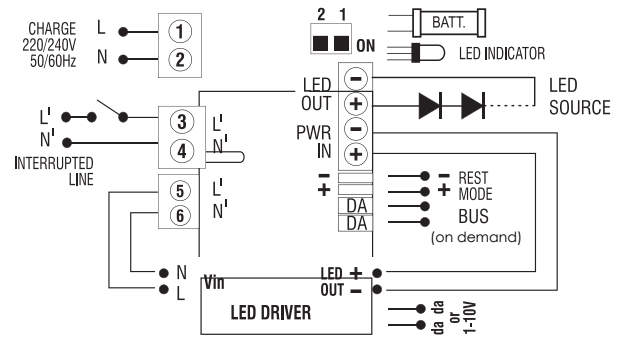

FIG.1



LIGAÇÃO EMERGÊNCIA



LIGAÇÃO REGULAÇÃO DALI

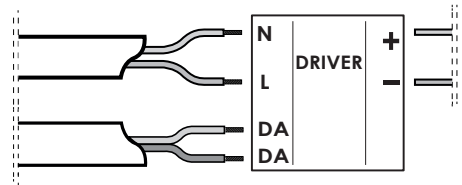

LIGAÇÃO REGULAÇÃO 1-10V

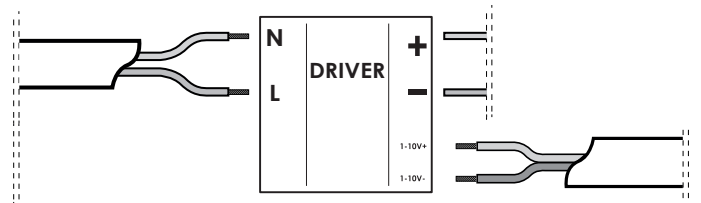

FIG.2

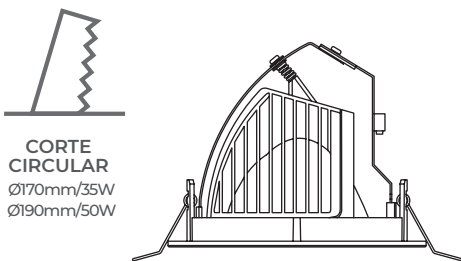
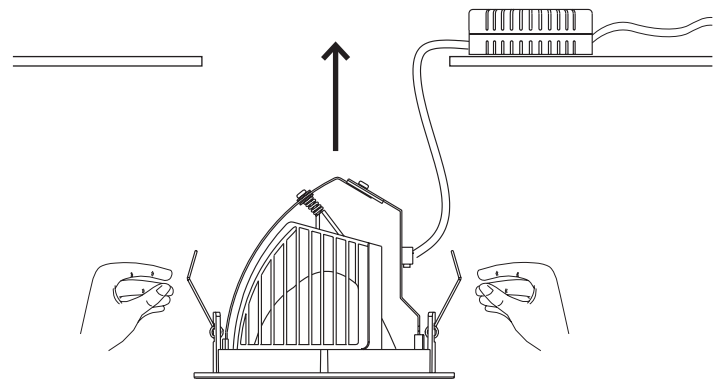

FIG.3



POSIÇÃO DO DRIVER

