

LIGHTING-FLOW DIMMER STABILIZER.



ILUEST+

1. INTRODUCTION.

- 1.1. GRATEFULNESS LETTER.
- 1.2. USING THIS MANUAL.
 - 1.2.1. Used symbols and conventions.
 - 1.2.2. For more information and/or help.
 - 1.2.3. Safety and first aid.

2. QUALITY AND STANDARD GUARANTEE.

- 2.1. MANAGEMENT DECLARATION.
- 2.2. STANDARD.
- 2.3. ENVIRONMENT.

3. PRESENTATION.

- 3.1. VIEWS AND LEGENDS.
 - 3.1.1 Views of all formats of the equipment.
 - 3.1.2. Corresponding legends to the equipment views.
 - 3.1.3. Control card BM491*, AC/DC power supply or digital I/O (option).
- 3.2. NOMENCLATURE AND STRUCTURAL DIAGRAM.
 - 3.2.1. Nomenclature.
- 3.3.- DESCRIPTION OF THE SYSTEM.
 - 3.3.1.- Introduction.
 - 3.3.2.- Structural diagram.
 - 3.3.3.- Constructive blocks.
 - 3.3.4.- Operating principle.
 - 3.3.5.- Formats or finishes.
 - 3.3.6.- Versions.
- 3.4.- OPTIONAL.
 - 3.4.1.- Lightning arrester of 6,5 kA for input and/or output.
 - 3.4.2.- Manual Bypass switch.
 - 3.4.3.- Control card BM491*00, digital I/O.
 - 3.4.4.- SICRES communication card.
 - 3.4.5.- GSM/GPRS modem.

4.- INSTALLATION.

- 4.1.- IMPORTANT SAFETY INSTRUCTIONS.
- 4.2.- RECEPTION OF THE EQUIPMENT.
 - 4.2.1.- Unpacking and content checking.
 - 4.2.2.- Storage.
 - 4.2.3.- Location.
- 4.3.- ASSEMBLING OF THE DIFFERENT FORMATS AND VERSIONS.
- 4.4.- COOLING.
- 4.5.- RECOMMENDED PROTECTIONS AND CROSS CABLE SECTIONS.
 - 4.5.1.- Recommended protections.
 - 4.5.2.- Recommended cross cable sections.
 - 4.5.3.- Installation diagrams.
- 4.6.- WIRING.
 - 4.6.1.- Connecting power supply.
 - 4.6.2.- Connecting remote control, saving order.
 - 4.6.3.- Connecting remote control, Bypass order
 - 4.6.4.- Connecting output.
 - 4.6.5.- Power supply of control card BM491*.
 - 4.6.6.- Connection of the coil of headline contactor.
 - 4.6.7.- Manual Bypass.

- 4.7.- SELECTOR FOR ON-OFF AUTOMATIC / START UP (ON), MANUAL / OUTPUT VOLTAGE OFF.
- 4.8.- COMMUNICATION BUS OF MODULES AND PORTS.

5.- OPERATING.

- 5.1.- START UP AND SHUTDOWN.
 - 5.1.1.- Controls before starting up.
 - 5.1.2.- Start up.
 - 5.1.3.- Complete shutdown of the equipment.
 - 5.1.4.- Manual Bypass.
- 5.2.- OPTICAL LED INDICATORS.
- 5.3.- SETTINGS.

6.- CONTROL PANEL WITH LCD.

- 6.1.- DEFINITION OF KEYBOARD AND ITS OPERATING.
- 6.2.- BASIC FUNCTIONS OF KEYBOARD FROM SYNOPTIC.
- 6.3.- SCREEN DESCRIPTION.
 - 6.3.1.- Main screen «Start».
 - 6.3.2.- Menu «Measurements» (Screen 1.1).
 - 6.3.3.- Menu «Alarms» (screen 2.1).
 - 6.3.4.- Menu «Data logger» (Screen 3.1).
 - 6.3.5.- Menu «General parameters» (Screen 4.1).
 - 6.3.6.- Menu «ILUEST+ parameters» (Screen 5.1).
 - 6.3.7.- Menu «Relay setting» (Screen 6.1).
 - 6.3.8.- Menu «Time scheduler» (Screen 7.1).
 - 6.3.9.- Menu «Astronomical clock» (Screen 8.1).
 - 6.3.10.- Menu «Energy counters» (Screen 9.1).
 - 6.3.11.- Menu «Password» (Screen 10.1).

7.- MAINTENANCE, WARRANTY AND SERVICE.

- 7.1.- BASIC MAINTENANCE GUIDE.
- 7.2.- TROUBLESHOOTING GUIDE (F.A.Q.).
 - 7.2.1.- If the equipment doesn't start up.
 - 7.2.2.- If the equipment is on Bypass.
- 7.3.- REPLACING ONE MODULE FROM ILUEST+ SET.
- 7.4.- WARRANTY CONDITIONS.
 - 7.4.1.- Covered product.
 - 7.4.2.- Warranty terms.
 - 7.4.3.- Out of scope of supply.
- 7.5.- AVAILABLE MAINTENANCE AND SERVICE CONTRACTS.
- 7.6.- TECHNICAL SERVICE NETWORK.

8.- ANNEXES.

- 8.1.- GENERAL TECHNICAL SPECIFICATIONS.
- 8.2. PARTICULAR TECHNICAL SPECIFICATIONS.
- 8.3.- GLOSSARY.

1. INTRODUCTION.

1.1. GRATEFULNESS LETTER.

We would like to thank you in advance for the trust you have placed in us by purchasing this product. Read this instruction manual carefully before starting up the equipment and keep it for any possible future consult that can arise.

We remain at your entire disposal for any further information or any query you should wish to make.

Yours sincerely,

SALICRU

- The equipment here described can cause important physical damages due to wrong handling. This is why, the installation, maintenance and/or fixing of the here described equipment must be done by our staff or specifically authorised.
- According to our policy of constant evolution, we reserve the right to modify the specifications in part or in whole without forewarning.
- All reproduction or third party concession of this manual is prohibited without the previous written authorization of our firm.

1.2. USING THIS MANUAL.

The target of this manual is to give explanations and procedures for the installation and operating of the equipment. This manual has to be read carefully before installing and operating it. Keep this manual for future consults.

This equipment has to be **installed by qualified staff** and, the simple help of this manual, **it can be usable by personnel without specific training**.

1.2.1. Used symbols and conventions.



«**Warning**» symbol. Carefully read the indicated paragraph and take the stated prevention measures.



«**Danger of electrical discharge**» symbol. Pay special attention to it, both in the indication on the equipment and in the paragraph referred to in this user's manual.



«**Main protective earthing terminal**» symbol. Connect the earth cable coming from the installation to this terminal.



«**Earth bonding terminal**». Connect the earth cable coming from the installation to this terminal.



«**Notes of information**» symbol. Additional topics that complement the basic procedures.



Preservation of the environment: The presence of this symbol in the product or in their associated documentation states that, when its useful life is expired, it will not be disposed together with the domestic residuals. In order to avoid possible damages to the environment, separate this product from other residuals and recycle it suitably. The users can contact with their provider or with the pertinent local authorities to be informed on how and where they can take the product to be recycled and/or disposed correctly.

1.2.2. For more information and/or help.

For more information and/or help of the version of your specific unit, request it to our Service and Technical Support (**S.T.S.**).

1.2.3. Safety and first aid.

Together with the equipment and this «User and installation manual», it is provided the information regarding to «Safety instructions» (See document EK266*08). Before proceeding to the installation or commissioning, check that **both information** are available; otherwise request them. It is obligatory the compliance of the «Safety instructions», being the user the legal responsible regarding to its observance. Once read, keep them for future consults that can arise.

2. QUALITY AND STANDARD GUARANTEE.

2.1. MANAGEMENT DECLARATION.

Our target is the client's satisfaction, therefore this Management has decided to establish a Quality and Environmental policy, by means of installation a Quality and Environmental Management System that becomes us capable to comply the requirements demanded by the standard **ISO 9001** and **ISO 14001** and by our Clients and concerned parts too.

Likewise, the enterprise Management is committed with the development and improvement of the Quality and Environmental Management System, through:

- The communication to all the company about the importance of satisfaction both in the client's requirements and in the legal and regulations
- The Quality and Environmental Policy diffusion and the fixation of the Quality and Environment targets.
- To carry out revisions by the Management.
- To provide the needed resources.

Management agent.

The Management has designated as management agent the person in charge about the Quality and Environment department, who with independence of other responsibilities, has the responsibility and authority to assure that the processes of the quality and environmental management system are established and maintained; to inform to the Management about the operating of the quality and environmental management system, including the necessities for the improvement; and to promote the knowledge of the client's requirements and environmental requirements at all the levels of the organization. In the next PROCESS MAP is represented the interaction among all the processes of the Quality and Environmental System:

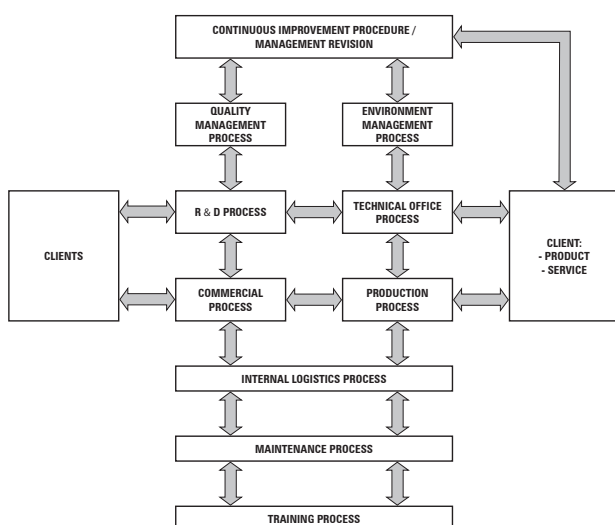

Fig. 1. Process map of Quality and environmental system.

2.2. STANDARD.

The **ILUEST+** product is designed, manufactured and commercialized in accordance with the standard **EN ISO 9001** of Quality Assurance. The **CE** marking shows the conformity to the EEC Directive (quoted between brackets) by means of the application of the following standards

- **2006/95/EC** Low voltage directive.
- **2004/108/EC** Electromagnetic Compatibility directive (EMC)

In accordance with the specifications of the harmonized standards. Norms as reference:

- **UNE-AENOR EA0032-2007**: Test report for lighting flow dimmer stabilizers equipments at headline. General and safety requirements of the central laboratory of electrotechnic (LCOE), report nr 20080710300.
- **IEC 62041**: Electromagnetic Compatibility (EMC).
- **UNE-AENOR EA0033-2007**: Test report for lighting flow dimmer stabilizers equipments at headline. Operating requirement from official central laboratory of electrotechnic (LCOE), report nr 200807100299.

2.3. ENVIRONMENT.

This product has been designed to respect the environment and has been manufactured in accordance with the standard ISO 14001.

Equipment recycling at the end of its useful life:

Our company commits to use the services of authorised societies and according to the regulations, in order to treat the recovered product at the end of its useful life (contact your distributor).

Packing: To recycle the packing, follow the legal regulations in force.

3. PRESENTATION.

3.1. VIEWS AND LEGENDS.

3.1.1 Views of all formats of the equipment.

Figures 2 and 3 show the views of **(OEM)** format, figures 4 and 5 the indoor one **(T)** and 6 the outdoor one **(I)**.

The figures only show all the connecting and manoeuvring parts that the fitter and/or user should know and/or manoeuvre for its correct installation, commissioning and operating (start up, shut-down, Manual Bypass operating, ...).

Regarding the views of **ILUEST+** in outdoor format **(I)**, see figure 4 for horizontal indoor format **(4)**, because the outdoor format **(I)** has an indoor format **(T)** basically, which is inside of an enclosure with IP54 protection degree.

For furthermore details regarding of the modules views see figures 2 and 3.

Regarding the legends related with the numbering of all figures see next section 3.1.2.

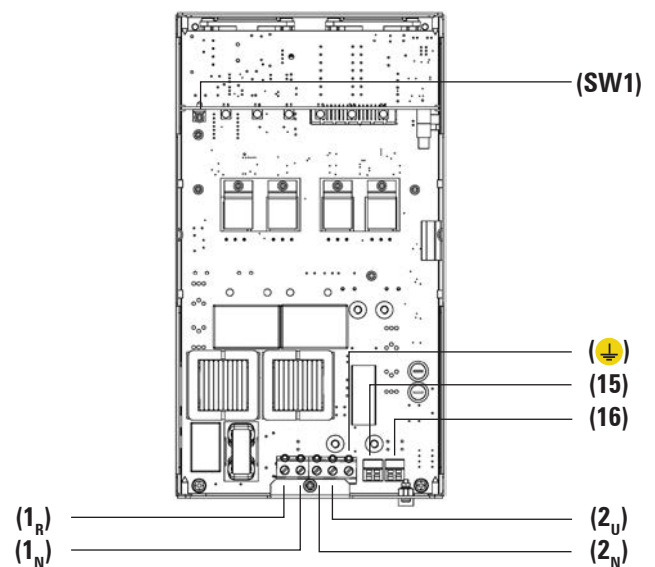
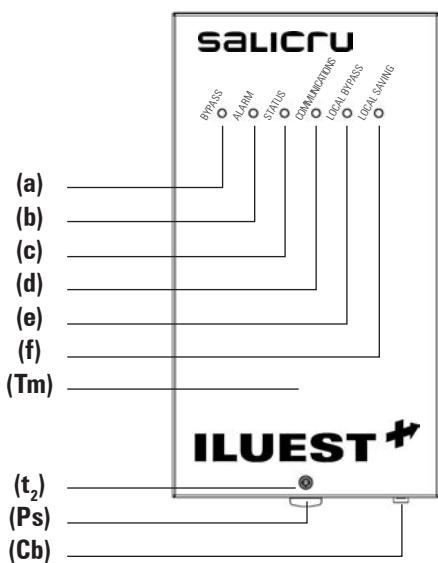

Basic module. Format No 1.

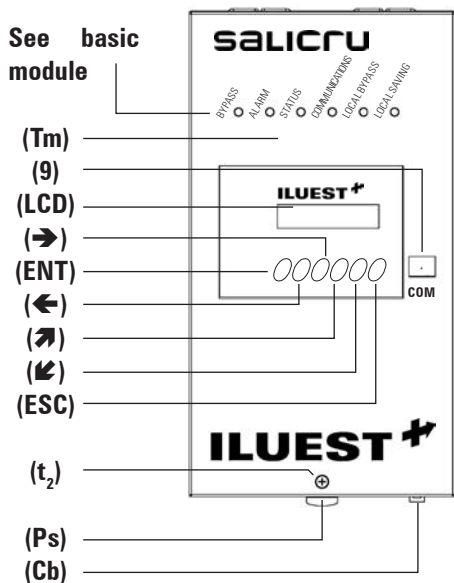

! **Note over the terminal strip (17).**

COM. Common
NC Normally closed
NO Normally open

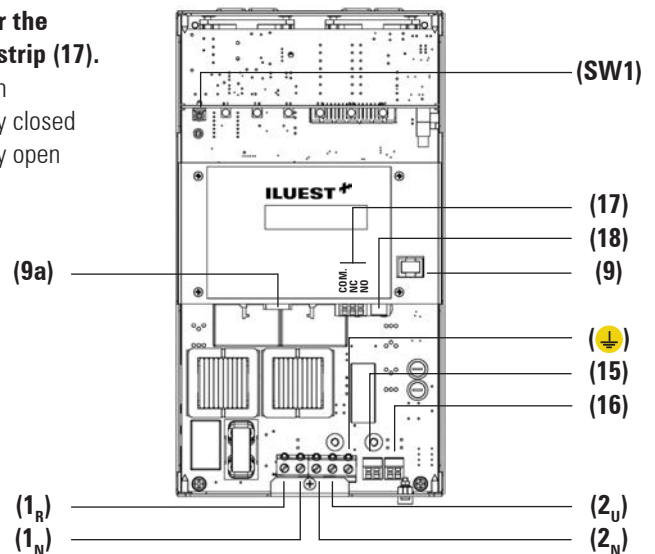

Module with LCD. Format No 1.

Fig. 2. Single phase views in **(OEM)** format No 1 with and without front cover **(Tm)**.

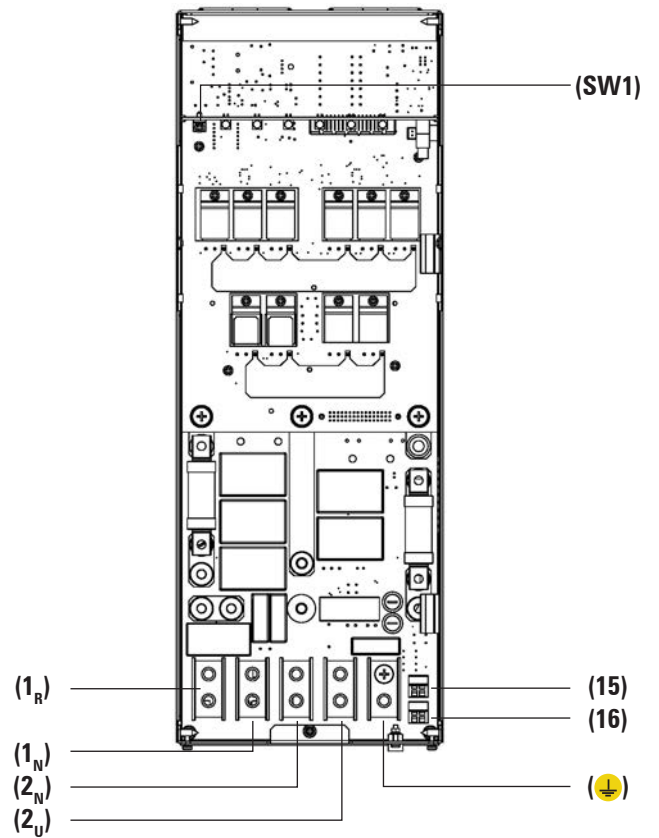
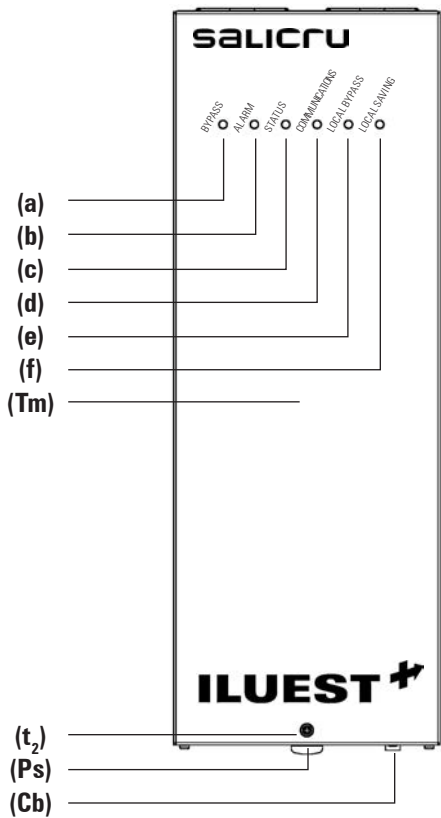

Basic module. Format No 2.

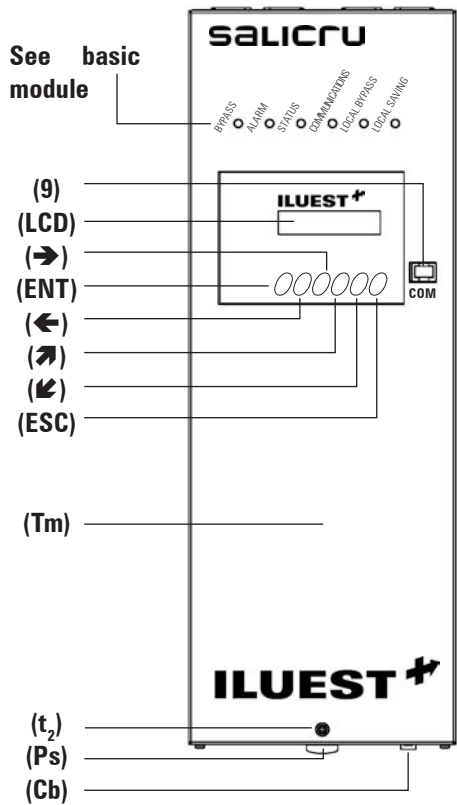

! Note over the terminal strip (17).
COM. Common
NC Normally closed
NO Normally open

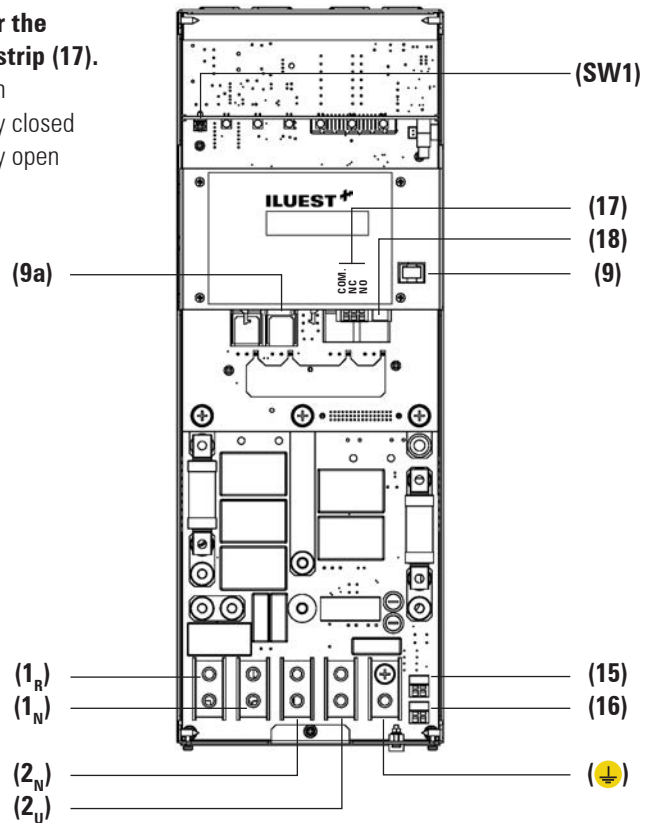

Module with LCD display. Format No 2.

Fig. 3. Single phase views in (OEM) format No 2 with and without front cover (Tm).

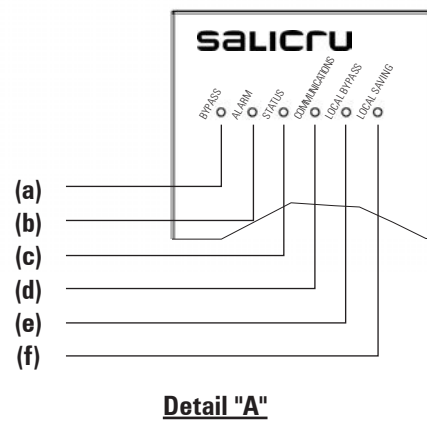
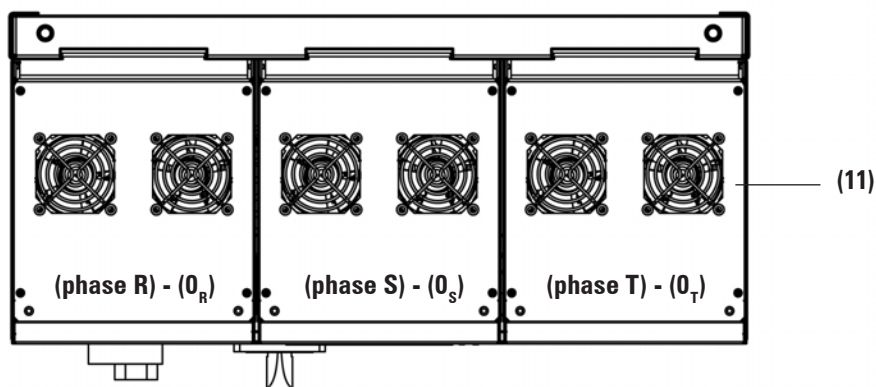
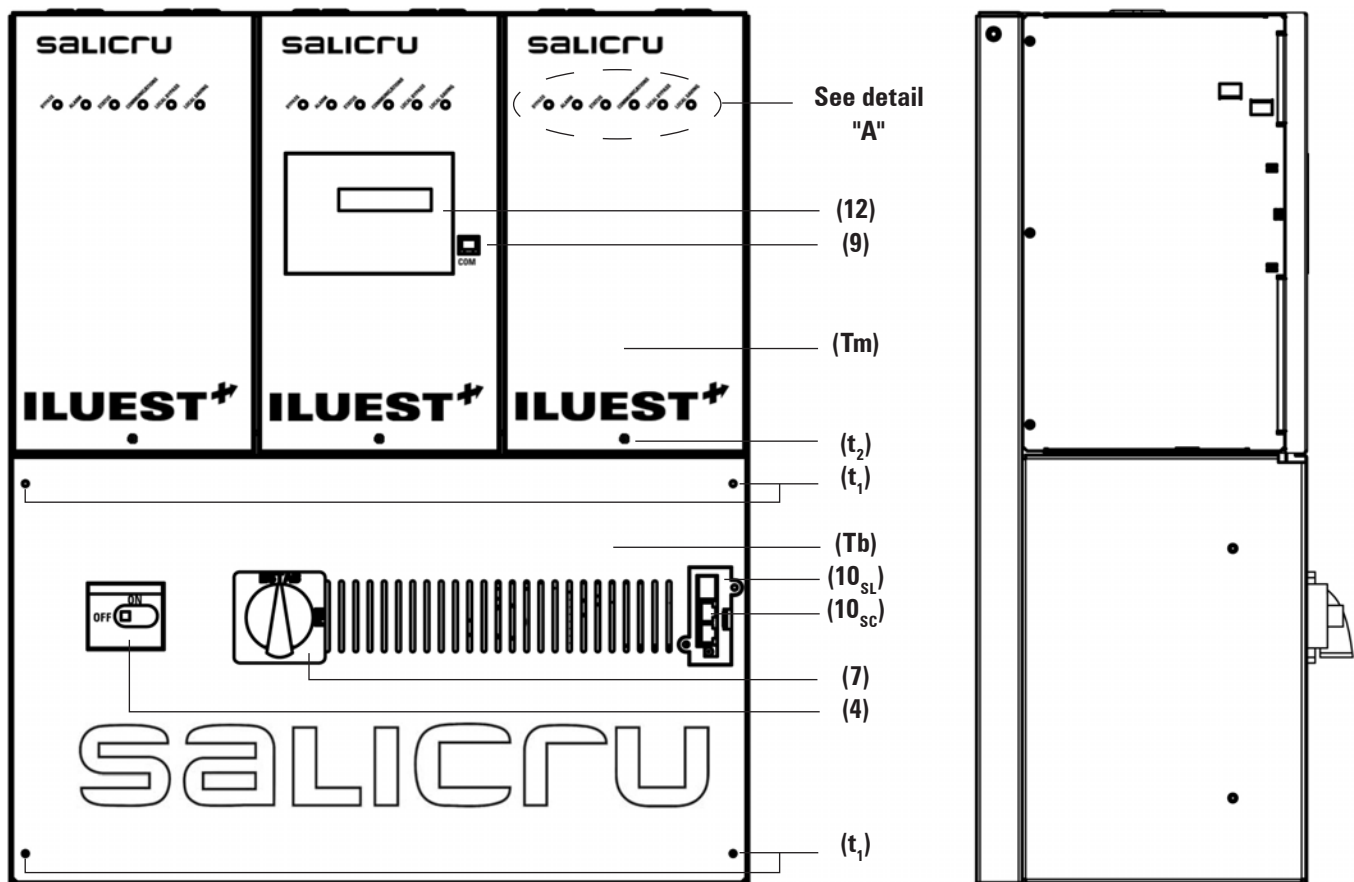
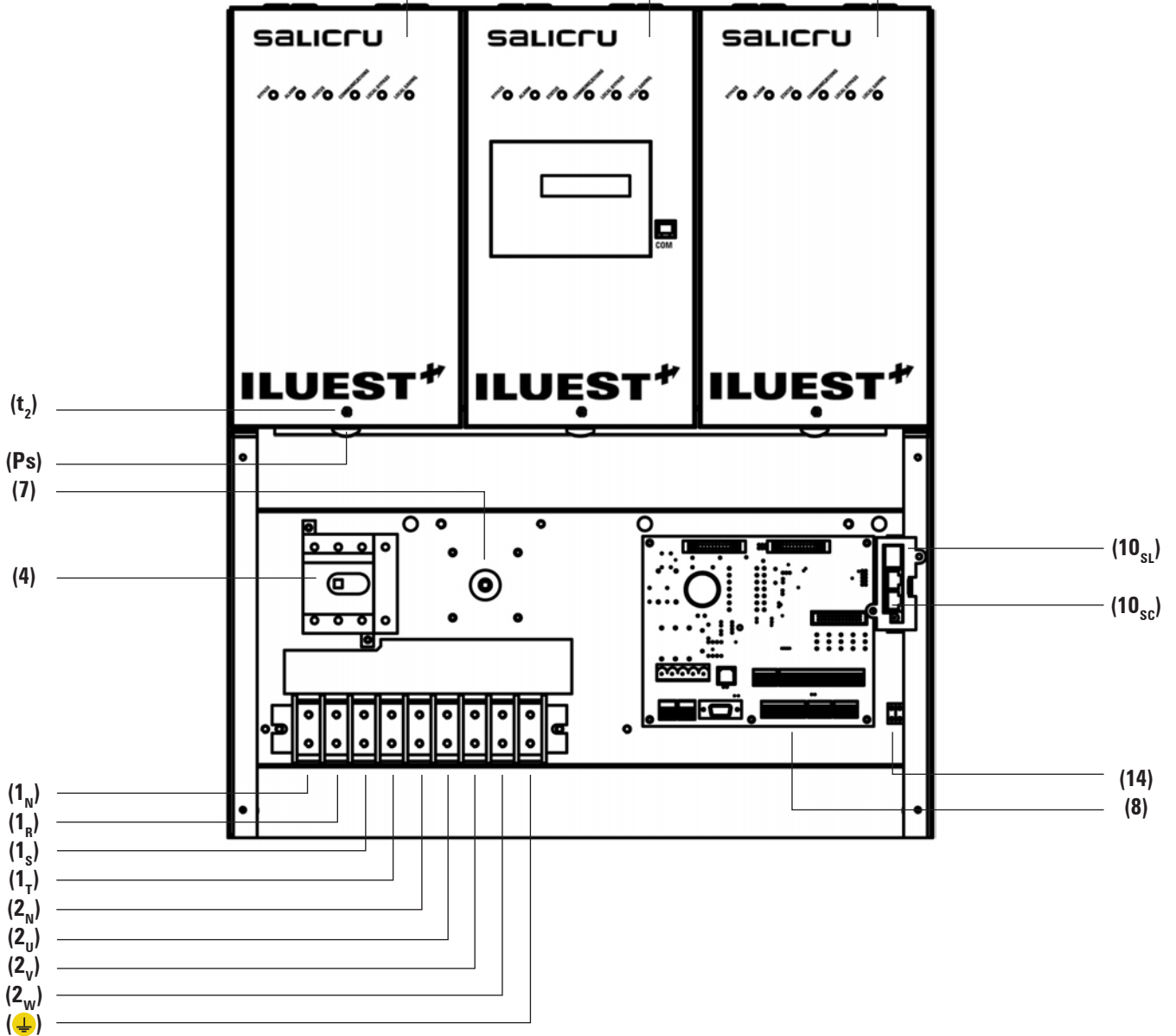

Fig. 4. Views for horizontal indoor format (T).

Factory default selection of the direction of the modules:

1 (phase R) - (0_R) 2 (phase S) - (0_S) 3 (phase T) - (0_T)



Extended detail of the frontal view of the ILUEST+ in execution indoor (T) in horizontal format and without the protection terminal cover (Tb)

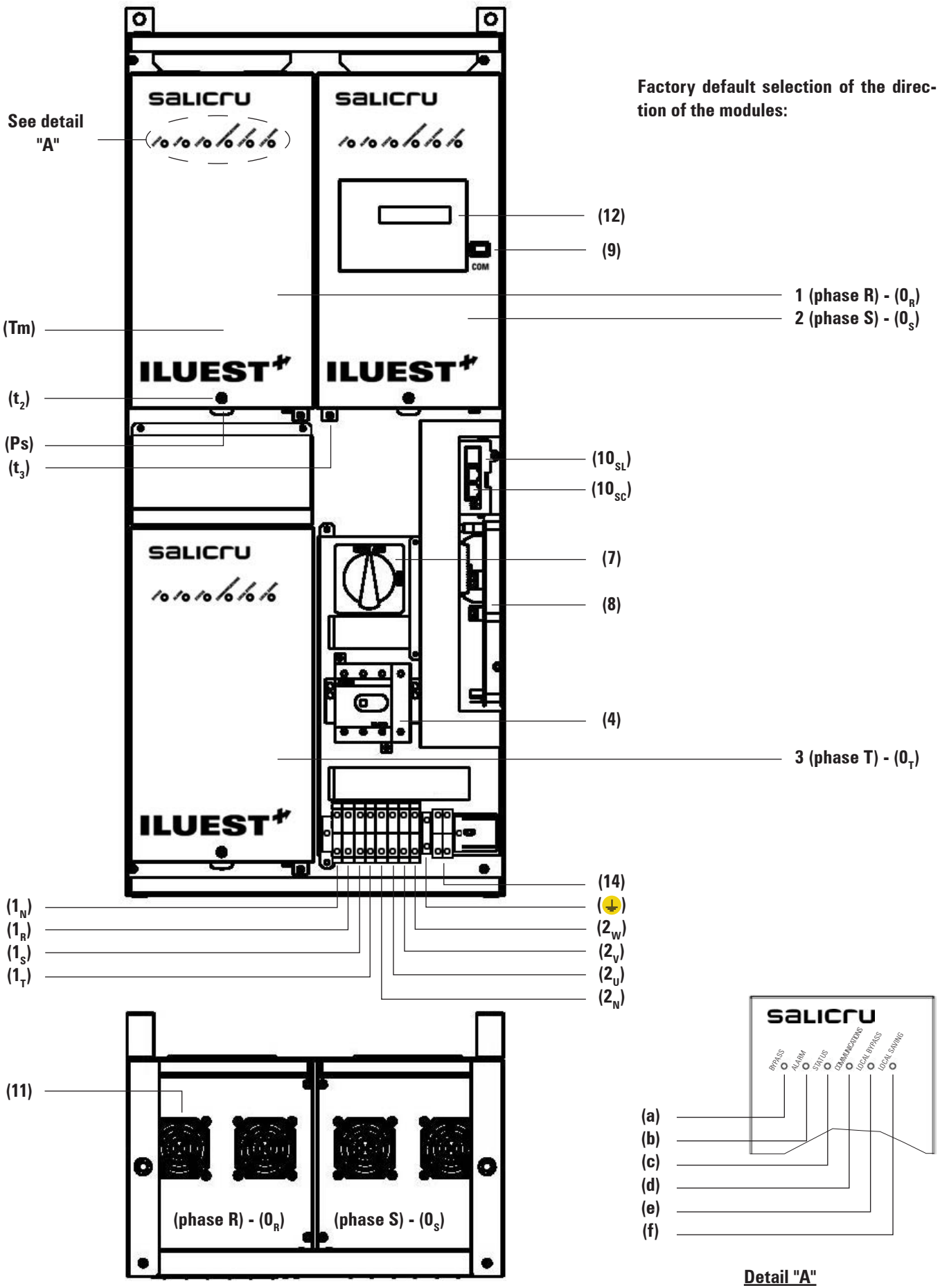

Fig. 5. Views for vertical indoor format (TW)

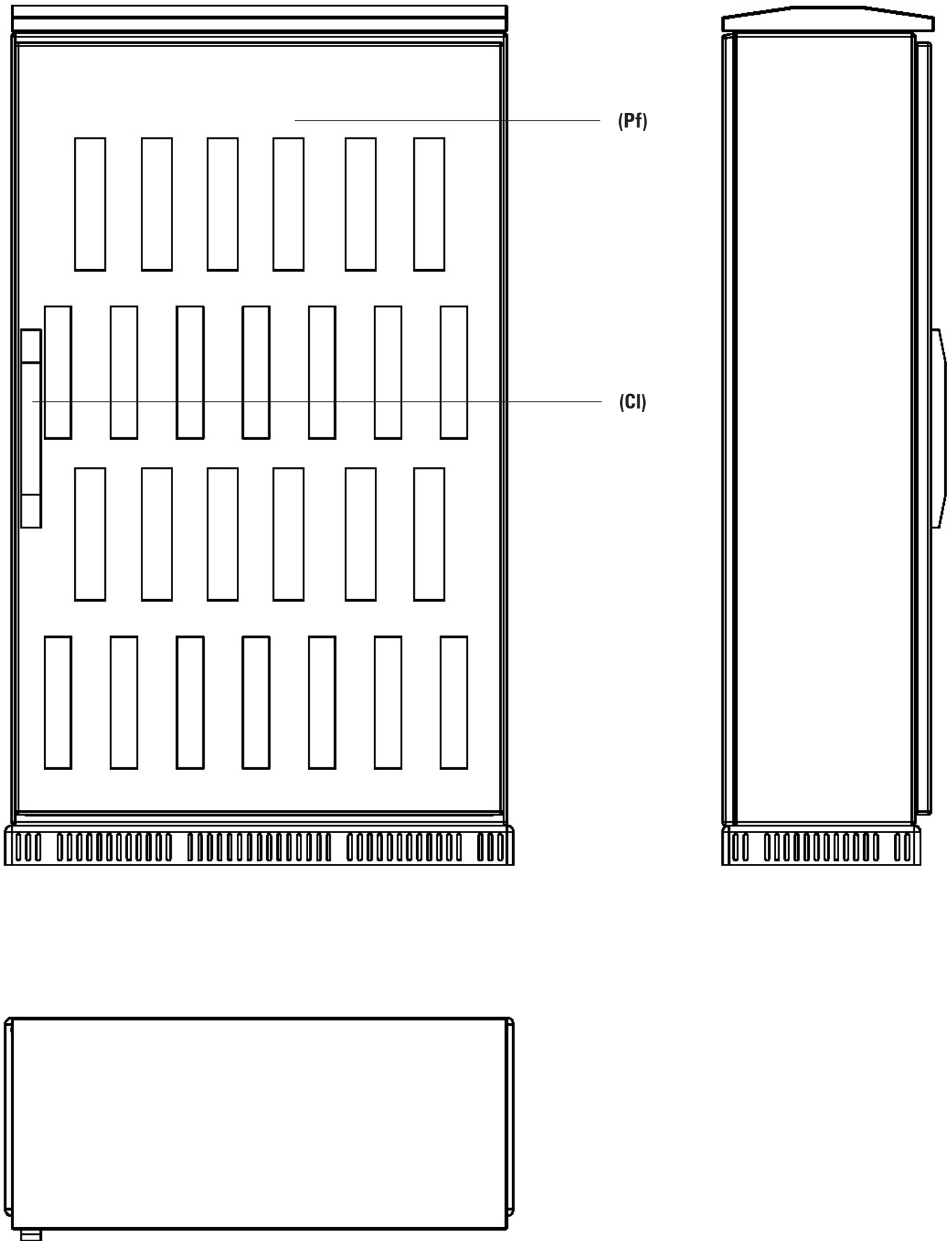

Fig. 6. Views for outdoor execution **(I)**, with the front door closed **(Pf)**.

3.1.2. Corresponding legends to the equipment views.

- (0) Single phase module **ILUEST+**. In three phase equipments there is one per phase (**0_R**), (**0_S**) and (**0_T**).
- (1_N) Neutral input terminal N.
- (1_R) Phase input terminal R.
- (1_S) Phase input terminal S.
- (1_T) Phase input terminal T.
- (2_N) Neutral output terminal N.
- (2_U) Phase output terminal U.
- (2_V) Phase output terminal V.
- (2_W) Phase output terminal W.
- (⊕) Main earthing protection terminal.
- (4) Two or four poles input switch (Positions: 0 and 1).
- (7) Manual bypass switch make before break (Optional).
- Position «1», lighting supplied by mains (Bypass).
- Position «2», lighting supplied by ILUEST.
- (8) Control card, AC/DC power supply BM491*01 or I/O digital BM491*00 (Optional).
- (9) RJ connector for RS-232.
- (9a) RJ connector for RS-485 (Optional on the LCD panel).
- (10_{st}) Slot for SICRES card.
- (10_{sc}) SICRES card (Optional).
- (11) Fans, forced cooling.
- (12) Control panel:
(**LCD**) LCD panel.
(**ENT**) Key «ENTER».
(**ESC**) Key «ESC».
(**↑**) Key move up.
(**↓**) Key move down.
(**→**) Key move to right.
(**←**) Key move to left.
- (13) Led optical indications:
(a) Red led indicator for «Bypass».
(b) Red led indicator for «Alarm».
(c) Green led indicator for «Status».
(d) Yellow led indicator for «Communications»..
(e) Yellow led indicator for «Local Bypass».
(f) Yellow led indicator for «Local saving».
- (14) Power supply terminals for coil contactor (equipments with Manual Bypass only (**7**)).
- (15) Terminal strip for saving order in module «Save On».
- (16) Terminal strip for bypass order in module «Bypass On».
- (17) Terminal strip for ON/OFF manoeuvring, headline contactor.
- (18) Power supply jack of LCD control panel of module.
- (Cb) Communication bus connector of each module.
- (CI) Handle to open-close the front door of the cabinet by means of bolts (outdoor format (**I**)).
- (Fc) Cable of 10 pins for communication between modules.
- (Pf) Front door with shelf (outdoor format (**I**)).
- (Ps) Module cover rim (**O**).
- (SW1) Dipswitch to set the module address.
- (Tb) Cover for connecting parts (formats (**T**) and (**I**)).
- (Tm) Cover for connecting parts and setting (format (**OEM**)).
- (t₁) Bolts for cover fixing (**Tb**).
- (t₂) Bolt for module cover fixing (**Tm**).
- (t₃) Bolts for module fixing.

3.1.3. Control card BM491*, AC/DC power supply or digital I/O (option).

This card has two versions depending on its function:

- A basic one and as simple AC/DC power supply that allows feeding the LCD panel and SICRES card option. This version is standard in all units with formats indoor (**T**) and outdoor (**I**) and it is integrated in the equipment (see figure 7).
- Optional with digital I/O that replaces the basic one in formats (**T**) and outdoor (**I**). As well as being a AC/DC power supply, it has the available ports to communicate **ILUEST+** with the environment (see figure 8).

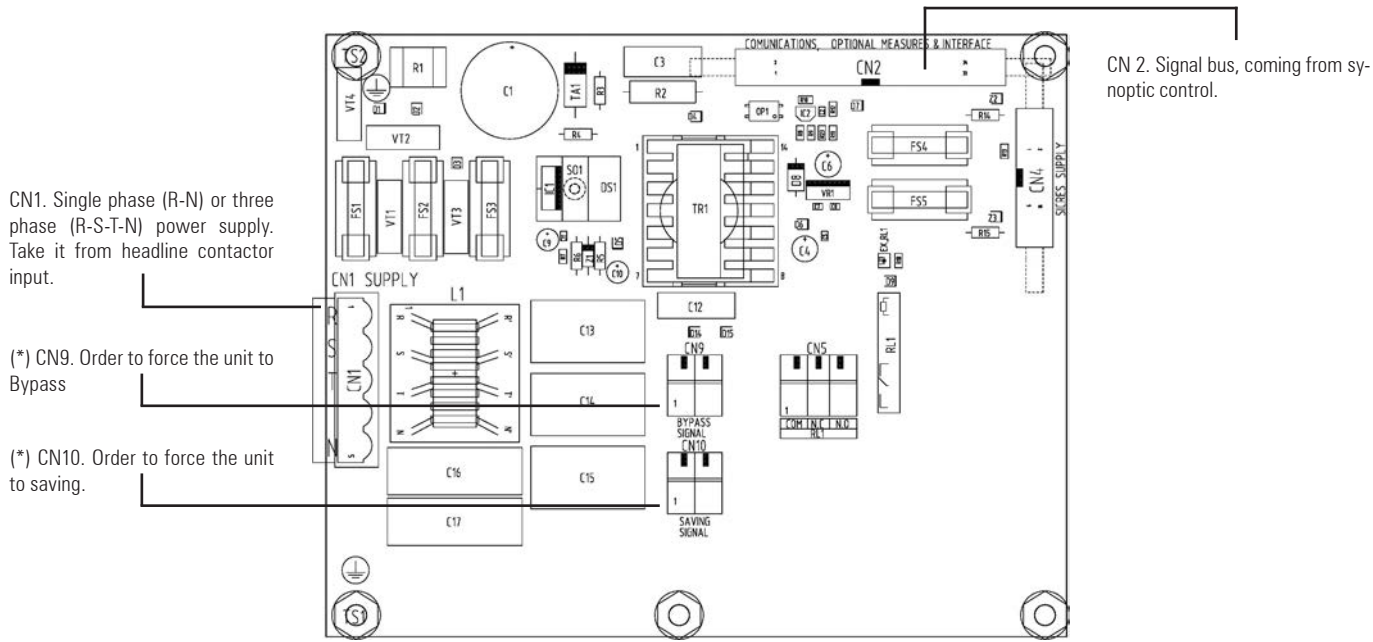

CN1. Single phase (R-N) or three phase (R-S-T-N) power supply. Take it from headline contactor input.

(*) CN9. Order to force the unit to Bypass

(*) CN10. Order to force the unit to saving.

CN 2. Signal bus, coming from synoptic control.

Fig. 7. Standard control card BM491*01, AC/DC power supply (Basic for format **(T)** and **(II)**).

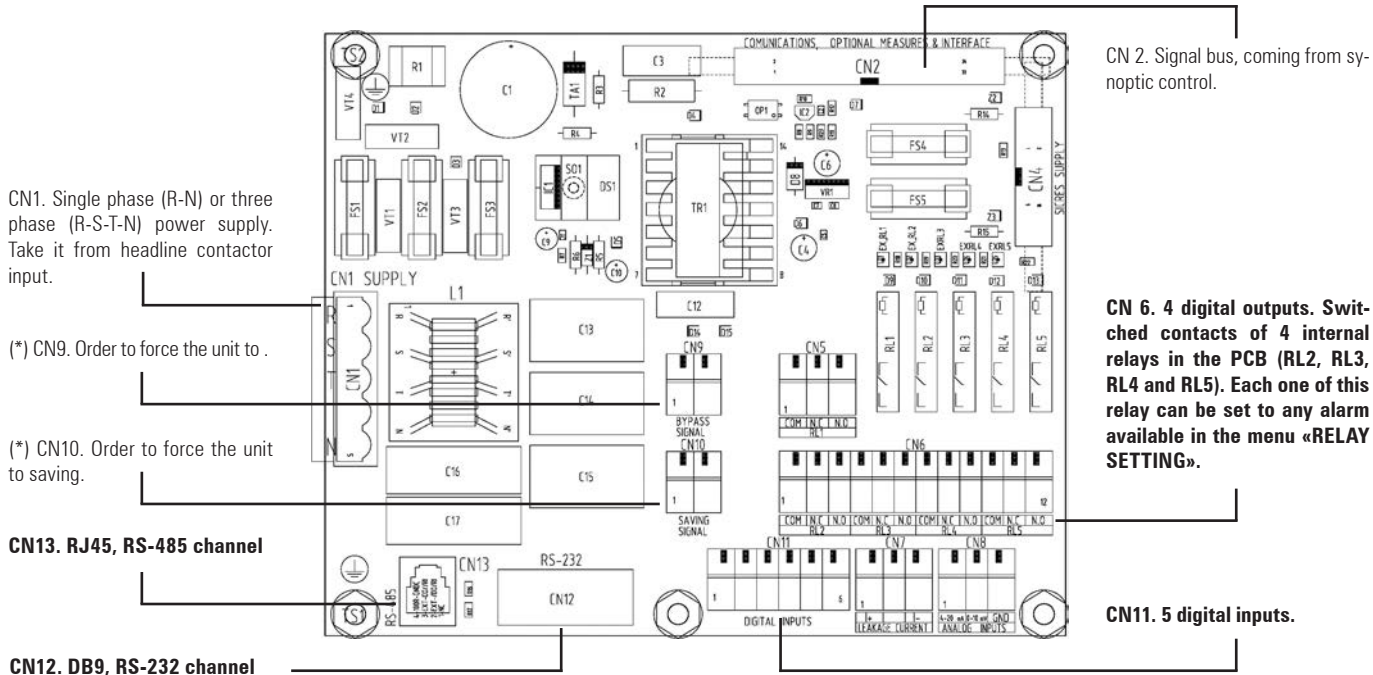

CN1. Single phase (R-N) or three phase (R-S-T-N) power supply. Take it from headline contactor input.

(*) CN9. Order to force the unit to .

(*) CN10. Order to force the unit to saving.

CN13. RJ45, RS-485 channel

CN12. DB9, RS-232 channel

CN 2. Signal bus, coming from synoptic control.

CN 6. 4 digital outputs. Switched contacts of 4 internal relays in the PCB (RL2, RL3, RL4 and RL5). Each one of this relay can be set to any alarm available in the menu «RELAY SETTING».

CN11. 5 digital inputs.

! (*) CN9 and CN10. Order to force the unit to bypass and/or saving (use a dry contact to close the circuit **-NEVER APPLY VOLTAGE-**).

Fig. 8. Control card BM491*00, with digital I/O (Optional).

3.2. NOMENCLATURE AND STRUCTURAL DIAGRAM.

3.2.1. Nomenclature.

Single phase ILUEST+ series.

NE+ 10-2IBMD/D-COM2 220V 60Hz "EE84526"

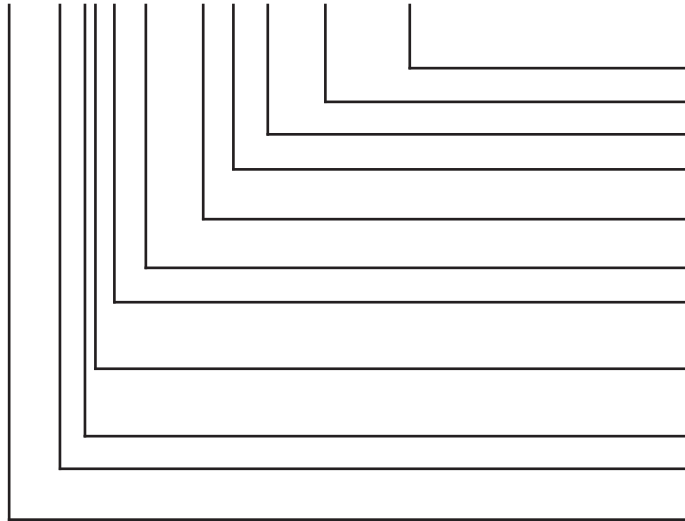

Special equipment "EE".
Frequency if it is not 50Hz.
Voltage if it is not 230V.
2 Digital inputs, relay interface, RS-232 and 485.
COM SICRES communication card.
LCD (*) Control panel with LCD.
D/D Lightning arrester 6,5 kA, at input and/or output.
BM Manual bypass.
I Outdoor format.
T Indoor format
No indication for OEM format (Kit NE+).
First character of voltage.
Power of the equipment in kVA.
NE+ NE+ series.
Kit NE+ For OEM format (fitter).

ILUEST+ three phase series.

NET+ 10-3IBMD/DW-COM2 3X380V 60Hz "EE84526"

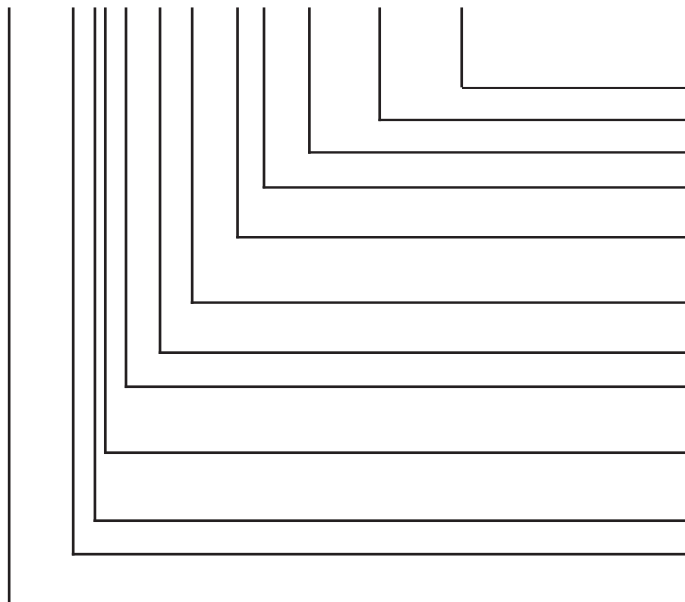

Special equipment "EE".
Frequency if it is not 50Hz.
Voltage if it is not 3X400V.
2 Digital inputs, relay interface, RS-232 and 485.
COM Communication card.
LCD (*) Control panel with LCD.
W Vertical version.
No indication for horizontal version.
D/D Lightning arrester 6,5 kA at input and/or output.
BM Manual Bypass.
I Outdoor format.
T Indoor format.
No indication for OEM format (Kit NET+).
First character of voltage.
Power of the equipment in kVA.
NET+ NET+ series.
Kit NET+ For OEM format (fitter).

(*) Each equipment is supplied from factory with only one LCD, so a three phase system, only one module will have it.

i The first abbreviation means, as well as the denomination of the equipment, is electrical nature: NET+ for three phase units and NE+ for single phase units.

3.3.- DESCRIPTION OF THE SYSTEM.

3.3.1.- Introduction.

ILUEST+ is an electronic dimmer-stabilizer system of alternating voltage to control and dim the lighting flow in lighting installations. That control of lighting flow allows obtaining both an energy saving and high comfort in the street lighting.

Also, by just only stabilizing the power supply of the lighting, the lamp lifetime is prolonged notably, because in normal conditions they are exposed to mains fluctuations and indirectly, there is a saving in the electrical energy when the power supply to the lamps is stabilized.

ILUEST+ is a chopper power converter. By doing a certain Duty Cycle, there will be a concrete alternating voltage level at the output without needing to modulate the cycle to get a sinewave voltage, because there is not any rectifier and conversion to direct current.

The converters of those stabilizers are bi-directional, and they are provided with parts to recover the reactive current feedback to mains, because the typical lighting installation (with discharge lamps of mercury or sodium vapour gas) are always reactive (leading or lagging depending on the compensated degree of power factor and operating voltage), and non-linear with harmonic currents.

All converters will be both semiconductor devices managed through switching and bi-directionals.

In three phase dimmer-stabilizers, each module that make up **ILUEST+** works in an independent way, one per each phase, so each one will correct the fluctuations of that phase only.

3.3.2.- Structural diagram.

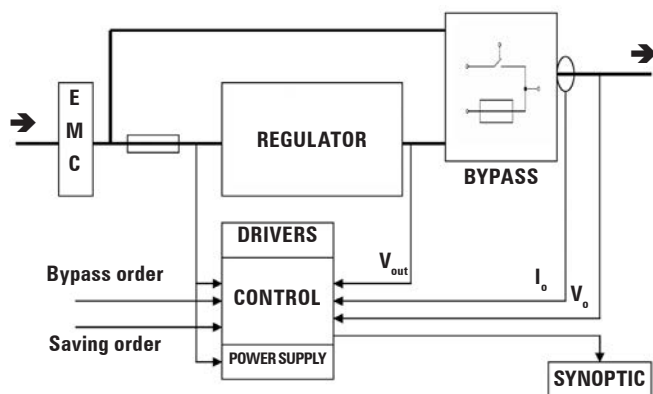

Fig. 9. **ILUEST+** single line diagram.

3.3.3.- Constructive blocks.

EMI INPUT FILTER.

The equipment has an EMI filter at the input to avoid reinjecting the electrical noise generated by its switching to the mains. The filtered voltage is taken from both Bypass directly and from a fuse to the converter.

VARISTORS PROTECTION (MOV).

The equipment has varistors at both input and output to avoid transient voltages that could damage the unit. Those varistors are protected by fuses to avoid their destruction by high or prolonged input overvoltages.

REGULATOR WITH BUCK AC CONVERTER.

Basically, the differences as regard a Buck converter in DC systems is to replace the single direction switching parts by bi-directional parts and to establish strategies or methods of triggering that allows managing lagging-leading currents phase shifted with voltage. In AC systems with inductive or capacitive loads, there are currents that flow from mains to load and from load to mains through the equipment, so it has to allow the flow in both directions. This is why diodes can't be used as switching parts; they have to be replaced by IGBTs, which make to define a triggering system suitable to the voltage polarity at each moment.

So far, we have referred to a single phase stabilizer for AC. In case of a three phase device, it is compulsory to treble the involved parts, less the LCD panel and communication card because they are common for all phases.

In lighting of big centers, like streets, car parks or highways, the energy distribution is usually done in three phase. The described equipments, starting from single phase devices and thanks to its modular structure, can be easily built in three phase stabilizers, which is made of three independent modules connected in star configuration, so one, two or three phases can operate at different levels if it were required.

POWER SUPPLY.

The power supply of the control of the equipment is fed from input. It is a flyback power supply with multiple output winding that supply all control parts and front LEDs, also it has a multivibrator, which feeds several feedforward transformers of ferrite to create the needed voltage for the IGBT drivers.

CONTROL.

The control has a microprocessor of last generation that uses digital control techniques to achieve an output voltage with good accuracy and response time. Also the control acquire measurements, generates the PWM signal for controlling the output voltage, manages the overloads and wrong situations, controls the Bypass, controls the synoptic and serial communications. Also there are some light indicators to display the status of the regulator in an easy way.

BYPASS.

In normal conditions, the output of the regulator is supplied from converter output or in case of faults or overloads it is fed from input voltage. The Bypass technology is based on a hybrid switching technology plus a solid state switch (IGBT), which gives robustness to the manoeuvring,

with no transfer time and no looping currents to guarantee the lack of transients and overcurrents during the switching. Bypass is active by default, so if the control doesn't turn it off, it will still be connected. Also it can be set to automatic or manual through an external input because we can force it through it. Furthermore it is reversible, so when the cause that activated it is cancelled the unit will return back to normal operating.

Conditions to force the automatic shifting to bypass are:

- Overtemperature, detected by internal sensors.
- Output overload.
- Faulty IGBTs
- Output voltage fault.
- Manual activation.

DRIVERS.

Drivers trigger the IGBTs of voltage regulator and they have an individual protection system per each IGBT by reading the saturation voltage of the transistor and taking the needed actions in consequence.

LED INDICATORS AND SYNOPTIC WITH LCD PANEL.

All modules have six led indicators that light when its function is activated, additionally in each equipment, either single phase or three phase, there is a LCD panel, where in three phase units is a common part for all the modules of the system.

By means of this LCD panel, the status of the equipment can be known in real time like measurements, active alarms, data logger (list of the last 200 events), status and setting of the parameters, dry contact setting, timer and astronomical clock activation and setting, as well as the energy counters.

CONTROL CARD BM491*.

This card is not shown in the single line diagram of figure 9, because it doesn't belong to the basic structure, but although it is not fitted in all formats it has to be described. There are two versions, depending on its function:

- A **basic** one that is standard in all units with formats indoor (**T**) and outdoor (**I**) and it is integrated in the equipment.
 - AC/DC power supply instead, for feeding the LCD panel and another one for feeding the SICRES card.
 - 1 input for Bypass order.
 - 1 input for saving order.
 - Power supply of the contactor coil.
- **Optional** with digital I/O that replaces the basic one in formats (**T**) and outdoor (**I**). In addition to the benefits of the basic card it has the available ports to communicate **ILUEST+** with the environment, where there are:
 - 1 RS232 communication channel.
 - 1 RS485 RS232 communication channel.
 - 5 digital inputs.
 - 5 dry contacts (including headline contactor control).

Version with communication channels can be implemented from factory or in next future when would be required. Just consider that (**OEM**) format and due its structure, the communication card will be located beside the module and inside its enclosure or under an IP20 protection degree as minimum.

3.3.4.- Operating principle.

Dimmer stabilizer is installed at the beginning of the lighting line, either in the feeder pillar or in separate case, it is not needed any additional control wiring till the lamps (see fig.17 and 18 «Circuit diagram of typical installation», as an example they show two three phase installations and differentiated by the equipment format and therefore by the control card built in).

When the equipment receives voltage, it starts the daily duty cycle (see fig.10), doing a "soft start" of the installation, and starting from 210 V and keeping this level for 2' 30", after this period time starts the rise ramp till reaching the 220 V nominal in 5 minutes more. During all this start process, the voltage is stabilized at its corresponding values.

The values of voltage, time and speed ramp can be set.

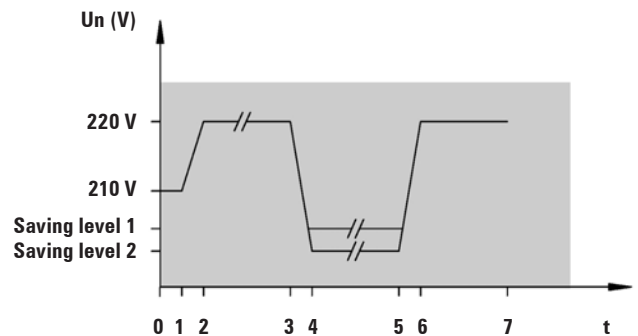

- 0.- Start up of the system.
- 1.- Warming up "soft ramp" starts.
- 2.- Nominal level.
- 3.- Saving order input is activated. Saving "soft ramp" starts.
- 4.- Saving level, it depends on the type of lamp.
- 5.- Saving order is deactivated and returns back to nominal level, also in "soft ramp".
- 6.- Nominal level operating till is turning off
- 7.- Daily turning off.

Fig. 10. ILUEST+ operating cycle.

Once the start up process is ended, the equipment will keep supplying stabilized voltage to the installation at nominal level, meanwhile the saving order is not activated. This order will come from an external device (timer, astronomical clock, remote control, manual activation, ...), which will be connected to the stated terminal strip of the equipment labelled as «Remote control». Afterwards a procedure of «saving in soft ramp» is started that takes, approx., 10 minutes, till the saving voltage.

This procedure can be repeated as many times as it were set, as well as there were mains blackouts or power failures.

3.3.5.- Formats or finishes.

ILUEST+ is showed in three formats or finishes, starting from the most basic one (**OEM**) and thanks to its modular structure:

- Format (**OEM**) -original equipment manufactured-. Protection degree IP20. Assembled in galvanised sheeted steel with painted covers in Epoxy coat of RAL-7032 colour with silk-screen.

Designed to make its adaptation in control centers more flexible. Basic version is one module with LED to control one phase, so a three phase system is based on three modules (**OEM**). Nevertheless one of the three modules of the three phase system has LCD panel as interface between the equipment and user, like the single module for single phase installations.

(**OEM**) module/s will be fixed in vertical position with the supplied supports:

- Directly to the wall.
- Inside of a metallic or plastic (like polyester) enclosure.

Each (**OEM**) module is supplied in unitary packing. So, three phase systems will be supplied with three independent packing, as well as another packing with the following parts for **OEM Kit** (See figure A):

- Single **OEM Kit** (see figure 14):
 - 1 AC/DC transformer power supply for LCD panel control.
 - 2 galvanised steel supports "**type A**", for vertical fixing. Bottom and top supports.
 - 1 CD with all the information (manuals, warranty,...).
- Three phase **OEM Kit** (see figure 15):
 - 1 AC/DC transformer power supply for LCD panel control.
 - 1 galvanised steel support "**type B**", for vertical fixing the three modules. Top support.
 - 3 galvanised steel supports "**type A**", for vertical fixing each module. Bottom supports.
 - "Communication bus" cable with three connectors.
 - 1 CD with all the information (manuals, warranty,...).

See the description in indoor format (**T**), regarding the cooling.

- Indoor format (**T**) with protection degree IP20, in horizontal or vertical (**W**) formats.

Standard configuration for a three phase indoor equipment:

- Three (**OEM**) modules, two with leds and one with LCD panel.
- Four poles input switch.
- Terminal strip, and control card BM491* used as AC/DC power supply.
- A metallic subchassis made of galvanised steel with covers. It is used as metallic protection enclosure, over it the modules and parts are fixed.

All the standardised optional of this user's manual, has a specific location inside the equipment less the GSM/GPRS modem and its antenna.

- 1 CD is supplied with all the information (manuals, warranty,...).

Dedicated to be installed in the own distribution, protection and control panel, over the floor or pedestal, or hanged up with the right mediums, but never outdoors.

In any case, the cooling air volume (stated in table 4) has to be respected for each power, considering that the forced air cooling is taken from front and canalized till its exhausting through the top cover.

The cooling air of the equipment can't be feedback when it installed inside the feeder pillar, because the internal temperature would increase till block it and leave it out of service. It is essential to leave the same cross cable section for inlet and outlet air in the feeder pillar.



Enclosures like feeder pillars, will have overtures for **ILUEST+** forced cooling, without endanger the standard meeting as regards of protection degree.

- Outdoor format (**I**). It is a **ILUEST+** with (**T**) format but built in a enclosure with protection degree IP54. Designed to be located outdoors. They do not require additional enclosures due to their protection degree.



Do not locate the equipment in areas exposed to floods.

3.3.6.- Versions.

ILUEST+ is presented in three versions, structured in incremental mode, so any version with higher range preserve the functionalities of the previous one and has new ones.

- Basic version. Equipment with led synoptic: Bypass, alarm, cycle, communications, saving and manual bypass.

This version is not commercialised, less as spare part in a three phase system because it is based on two basic (**OEM**) units and one (**OEM**) unit with LCD.

- LCD version. This version corresponds to a single (**OEM**) equipment or to "Master" module of the three phase system. Regulator equipment with LCD panel for local communication. Integrated by:

- LCD panel. It provides information of input / output voltages, frequency, load and saving percentage levels, output currents, power factor, data logger alarms, ..., and includes timer and astronomical clock.

- Digital I/O version. Regulator equipment with LCD panel for local communication. Integrated by:

- Control card BM491*00. Connection interface for 5 digital inputs and 5 digital outputs, RS-232 and RS-485 ports and inputs for saving and bypass orders. It includes timer, astronomical clock and data logger.

- COM version. Equipment with LCD version plus SICRES card for remote communication.

- SICRES card. Interface for Ethernet networks with TCP-IP and SNMP protocols and GSM / GPRS and RTC modems.

It is possible to make any **ILUEST+** format with any version of the equipment. Tables 1, 2 and 3 show the standardized configurations, relating the formats with versions.

3.4.- OPTIONAL.

3.4.1.- Lightning arrestor of 6,5 kA for input and/or output.

After the varistors (MOV) already installed at the input and output in each module, it is the top level in lightning arrestor protection. Also it can have indicators when it is activated and auxiliary contacts for its telemanagement.

3.4.2.- Manual Bypass switch.

Internal or external manual Bypass switch of 2 positions can be supplied, which allows to select to feed the **loads from mains directly (position 1)**, or through the **ILUEST+ (position 2)**. The switch is make before break, so there will not be any break in the loads during the changing in the position of the switch.

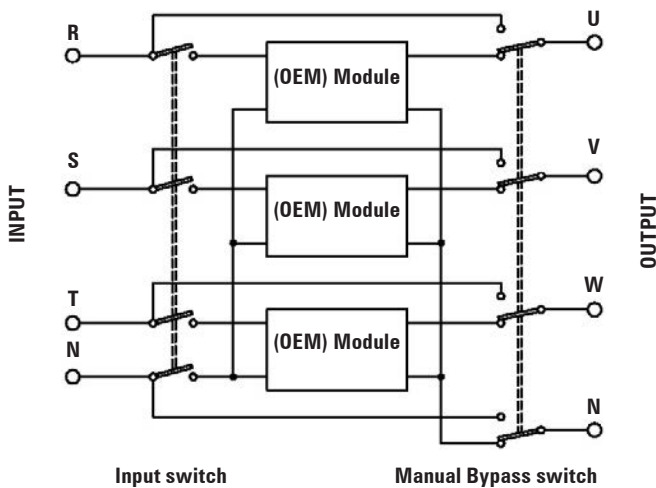

Fig. 11. Bypass manual connection diagram.

This switch, two poles for single phase units or four poles for three phase units, makes easier the maintenance tasks and it has an additional auxiliary contact to keep the headline contactor of the installation ON, so in indoor or tunnels installations the maintenance of any type can be done without turning off the lighting.

User can install an external manual Bypass make before break or break before make depending on his requirements, although the first one is the most advisable (see figure 11).

3.4.3.- Control card BM491*00, digital I/O.

This card concentrates all communication and control connections like:

- RS-232 (there will be two RS-232 connectors physically, one in DB9 and the other one in RJ, but only one can be used).
- RS-485.
- Programming alarm dry contacts (in case of having the LCD panel).
- Digital inputs.

3.4.4.- SICRES communication card.

SICRES communication card is able to provide a communication interface for ethernet networks with TCP-IP and SNMP protocols, GSM/GRPS modem and RTC modem.

RS-232 is not multiconnection (see manual EK764*01), so if this channel is gone to be used for any purpose, it will not be possible to make additional connections although the other connectors were available.

In **(OEM)** format:

- The SICRES card is supplied inside a metallic box. It is advisable to fix it to the wall or on some solid unremovable support.

This card communicates with the **ILUEST+** across the port RS-232, given in a connector RJ and next to the panel of control with display LCD. His power supply will be realized by means of the source given AC/DC and through the foreseen jack.

In **(I)** or **(T)** format:

- Equipment with slot for SICRES card. Just remove the protection cover and insert the communication card into the slot and it will run.

3.4.5.- GSM/GPRS modem.

It is in charge of doing the remote transmission of the parameters managed by SICRES card.

GSM/GPRS modem connection is used to have remote access to the equipment.

Depending on the contracted service, there will be access to the monitoring or to control the number of equipments installed (tele-maintenance).



ILUEST+ single phase (OEM).



ILUEST+ three phase (OEM).

Figure A. Representative example of provided material for single phase and three phase (OEM) equipments.

ILUEST+ (OEM) CONFIGURATIONS			
CONFIGURATION		FUNCTIONALITIES	COMMUNICATIONS
Module + LCD panel + AC/DC power supply for LCD panel		Lighting flow and saving + Measurement visualisation and parameter setting of the equipment + Control over the headline contactor + Saving and bypass orders + Timer and astronomical clock	RS-232 with complete three phase ModBus map
Module + LCD panel + AC/DC power supply for LCD panel	+ SICRES card + AC/DC power supply for SICRES card		Ethernet TCP/IP communication (web server at SICRES card)
Module + LCD panel + AC/DC power supply for LCD panel	+ SICRES card + AC/DC power supply for SICRES card		+ GSM/GPRS modem + AC/DC power supply for GSM/GPRS modem + Antenna

Table 1. Configurations for equipments with format (OEM).

CONFIGURATIONS FOR ILUEST+ INDOOR (T) / OUTDOOR (I)		
CONFIGURATION	FUNCTIONALITIES	
Chassis (T) / Chassis (T) + IP54 case for (I) + Switch + Terminals + 2 basic modules + 1 LCD module + Basic control card BM491*01 + Manual bypass switch (optional)	Lighting flow and saving + Measurement visualisation and parameter setting of the equipment + Control over the headline contactor + Saving and bypass orders + Communications + Timer and astronomical clock + Manual bypass (optional)	
Chassis (T) / Chassis (T) + IP54 case for (I) + Switch + Terminals + 2 basic modules + 1 LCD module + Basic control card BM491*01 + Manual bypass switch (optional)	+ SICRES card	RS-232 with complete three phase ModBus map + Ethernet TCP/IP communication (web server at SICRES card)
Chassis (T) / Chassis (T) + IP54 case for (I) + Switch + Terminals + 2 basic modules + 1 LCD module + Basic control card BM491*01 + Manual bypass switch (optional)	+ SICRES card	+ GSM/GPRS modem + AC/DC power supply for GSM/GPRS modem + Antenna
		RS-232 with complete three phase ModBus map + Ethernet TCP/IP communication (web server at SICRES card) + Remote GSM/GPRS communication through internet with website of SICRES card or SICRES Control Center.

Table 2. Configurations of equipments with indoor (T) and outdoor (I) formats.

CONFIGURATIONS FOR ILUEST+ INDOOR (T) / OUTDOOR (I) . Version with digital inputs and outputs (control card BM491*00)		
CONFIGURATION	FUNCTIONALITIES	
Chassis (T) / Chassis (T) + IP54 case for (I) + Switch + Terminals + 2 basic modules + 1 LCD module + Manual bypass switch (optional)	+ control card digital I/O BM491*00 (replaces basic card BM491*01)	
		Lighting flow and saving + Measurement visualisation and parameter setting of the equipment + Control over the headline contactor + Saving and bypass orders + Communications + Timer and astronomical clock + Manual bypass (optional)
Chassis (T) / Chassis (T) + IP54 case for (I) + Switch + Terminals + 2 basic modules + 1 LCD module + Manual bypass switch (optional)	+ control card digital I/O BM491*00 (replaces basic card BM491*01) + SICRES card	RS-232 with complete three phase ModBus map + RS-485 + Dry contacts + Digital inputs + Ethernet TCP/IP communication (web server at SICRES card)
Chassis (T) / Chassis (T) + IP54 case for (I) + Switch + Terminals + 2 basic modules + 1 LCD module + Manual bypass switch (optional)	+ control card digital I/O BM491*00 (replaces basic card BM491*01) + SICRES card	+ GSM/GPRS modem + AC/DC power supply for GSM/GPRS modem + Antenna
		RS-232 with complete three phase ModBus map + RS-485 + Dry contacts + Digital inputs + Ethernet TCP/IP communication (web server at SICRES card) + Remote GSM/GPRS communication through internet with website of SICRES card or SICRES Control Center.

Table 3. Configurations of equipments with indoor (T) and outdoor (I) formats, with digital inputs and outputs (card BM491*00).

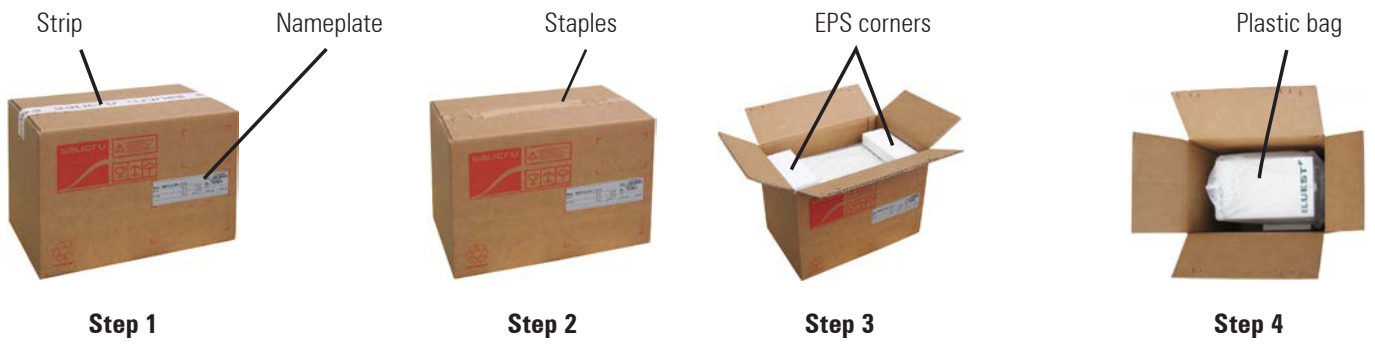

Fig. 12. Unpacking process for module (OEM).

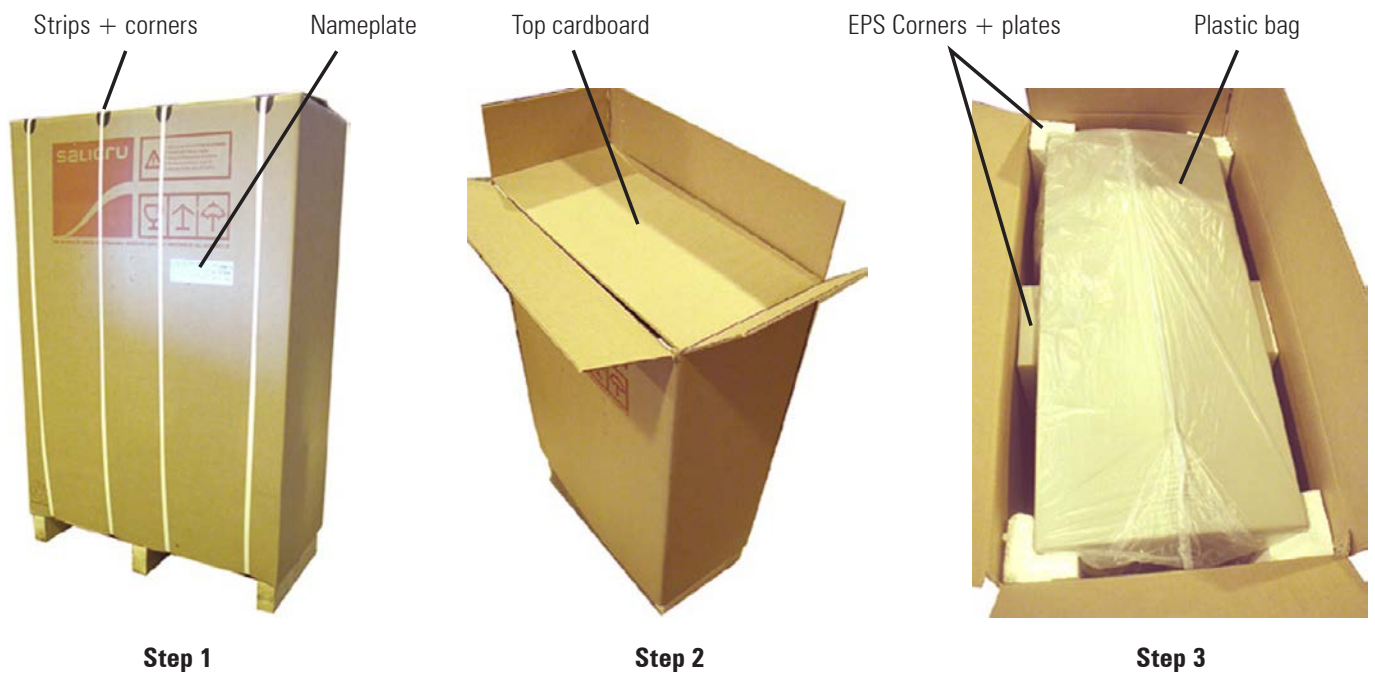

Fig. 13. Unpacking process for indoor (T) and outdoor (I) equipments.

4.- INSTALLATION.

4.1.- IMPORTANT SAFETY INSTRUCTIONS.

- Check "Safety instructions" (see document EK266*08).
- Unpacking procedure of the equipment is described in section 4.2. and illustrated by figures 12 and 13.
- **Never** make the connection tasks or manoeuvring of the cables that have risk of electrical discharge with voltage present.
- Check the data in the nameplate of the packing is the required by the installation (see figures 12 and 13).
- Depending on the format of the equipment to install, there will or not be available parts like input switch **(4)**. When it happens, omit any action, notes or warning related with it and proceed with the next step.
- **(OEM)** module/s of **ILUEST+** have to be fixed in vertical position directly to wall by means of the provided supports, inside of a metallic or plastic (like polyester) enclosure. It is compulsory to make this mechanical operating before proceeding with the installation (see figures 14 and 15), because the equipment is designed to work in this position for a better cooling and higher efficiency.
- Formats **(T)** and **(I)** of **ILUEST+** have 4 wholes of M8 for fixing it to a solid and levelled base, and other 2 additional wholes of $\varnothing 10$ mm in the format **(TW)** -indoor vertical- in the frontal face (figure sees 16).

It is obligatory to make this mechanical operation before proceeding with the installation (see figure 16).

- Location will be fresh and with easy access, **never** install the formats indoor **(T)** and **(OEM)** in outdoor conditions. Keep in mind the following statement .



The enclosures for switchgear panels, will have wholes for convection cooling of **ILUEST+**, without breaking the standards as regards of protection degree.

- Regarding cooling, respect the indications and recommendations in section 4.4.
- Do not block the cooling holes.
- Input switch**(4)** of the equipment, has to be in position "0" or "Off".
- To access to connection parts, open front door and/or remove the protection cover of the connection parts depending on the format of the equipment:

□ **(OEM)**.

- Remove screw **(t₁)** that fix cover **(Tm)** of module.
- Pull from cover **(Tm)** of module slightly by means of the rim **(Ps)** and lift the cover up to 2 cm, till leave free the rim that it is fitted in the module chassis, later on remove it.
- For three phase equipments, proceed in the same way for the rest of modules.
- Connection terminal strip will be in front.

- After finalising the connection tasks, leave the module with its cover **(Tm)** back and fixed with the screw **(t₁)**.

□ **(T)**.

- Remove screws **(t₂)** that fix cover **(Tb)**.
- Remove cover **(Tb)**.
- Connection terminal strip will be in front.
- After finalising the connection tasks, leave the module with its cover **(Tb)** back and fixed with the screws **(t₂)**.



In outdoor **(T)** and vertical format **(W)**, there is no cover **(Tb)** or screws **(t₂)**.

□ **(I)**.

- Open the front door **(Pt)** by means of supplied key.
- Remove screws **(t₂)** that fix cover **(Tb)**.
- Remove cover **(Tb)**.
- Connection terminal strip will be in front.
- After finalising the connection tasks, leave the module with its cover **(Tb)** back and fixed with the screws **(t₂)**.
- Close the front door **(Pt)** by means of supplied key.

- Equipments in formats **(T)** and **(I)** have cable gland holes (Not mounted in the execution **(TW)**), located at the bottom of the cabinet to enter the connection cables

(OEM) format has a slot in bottom side to enter the connection cables.

- Use cables with suitable cross section for input, output and earth (see table 5).
- **ILUEST+** connection will be done at the headline of the installation. Figures 17 and 18, and as an example, show a typical three phase installation diagram depending if it has or not control card BM491*00. For single phase equipments, simplify the connection disregarding the other phases.

- **ILUEST+** doesn't have circuit breakers nor differential protections and it depends of the installation external protections. Make sure about this compliance.

Nevertheless formats **(T)** and **(I)** have a general switch that break the power supply to the equipment.

- In case of requiring an external manual bypass, follow the following recommendations:

Bypass has to avoid the voltage feedback through the output of the equipment, in order to avoid both damages to the equipment (it is not protected against voltage connected at the output), and to manoeuvre the output terminals with no voltage and no risk. Therefore, Bypass has to disconnect the **ILUEST+** output when it is activated. Best option is a rotatory switch with two positions with its common pin connected to the load, one of its input pins connected to the output of the equipment and the other input pin to the alternative line (in case of failures), with or without overlapping depending on the type of installation (see figure 11).

4.2.- RECEPTION OF THE EQUIPMENT.

4.2.1.- Unpacking and content checking.

- When doing the reception of the equipment, check that there has not been any incident during transport. Otherwise, make the appropriate claims to your provider or in lack of him to our firm. Also check that the data in the nameplate adhered in the packing of the equipment are the same as the stated in the purchase order. Otherwise, as soon as possible make the dis-conformity, quoting the serial number of the equipment and refer-ences in the delivery note.
- Once the reception is done, keep the equipment in its original packing till its commissioning in order to protect it against me-chanical dents, dust, dirt, etc.
- Packing of the equipment has (see figures 12 and 13):
 - Format **(OEM)**.
 - Cardboard case, corners of expanded polystyrene (EPS) or polystyrene foam (PE), polyethylene bag. All parts are recyclable, so if they are gone to be disposed, do it in accordance with the current regulations. It is recom-mended to keep the packing in case it were needed in future.
 - Formats **(T)** and **(I)**.
 - Wooden pallet, cardboard or wooden (under request only) case, expanded polystyrene (EPS) or polystyrene foam (PE), polyethylene bag and polyester strips. All parts are recyclable, so if they are gone to be disposed, do it in accordance with the current regulations. It is recommended to keep the packing in case it were needed in future.
- Follow the steps of figures 12 and 13 for a correct unpacking of the equipment. Although pictures of figure 13 shows an outdoor **(I)** equipment only, proceed in the same way for indoor format **(T)**:
 - Cut the polyester strips that wrap the cardboard packing.
 - Open the flaps of the cardboard packing.
 - Take out the documentation.
 - Remove both corners and/or expanded polystyrene (EPS) plate or polystyrene foam (PE).
 - Take out the cardboard packing by pulling it up.
 - Remove the plastic bag of polystyrene that wraps the equipment.
 - Download the equipment from the pallet.Regarding the **(OEM)** format, as it doesn't bring polyester strip and pallet, its unpacking is more simple. Proceed as follows:
 - Remove the adhesive strip.
 - Take out the staples.
 - Open the flaps of the cardboard packing.
 - Take out the equipment from inside of the cardboard packing and remove the plastic bag of polystyrene (PE).
- In formats **(T)** and **(I)**, meanwhile the equipment is not in its final installation place, it is recommended to not download the equipment from the wooden pallet in order to make easy its mobility.

- Check that CD Installation and Operating manual comes to-gether with the equipment.

4.2.2.- Storage.

Due to the lack of batteries and/or other parts sensitive to time goes by, the only norms to meet for a correct storage are to leave it in places free of dust, humidity, chemical agents or high tempera-tures.



In case of piling up, do not exceed more than two units of height for formats **(T)** and **(I)**, because packing is not built in to support higher compression. Regarding **(OEM)** format, **never** pile up more than five units of height and in case of piling it up **al-ways** do it with the equipment arranged in horizontal way.

4.2.3.- Location.

Location of the equipment will depend on the format.

In case of outdoor format **(I)**, the equipment will be placed over a pedestal made of concrete and fixed through bolts to it firmly. Due to its protection degree IP54 will be able to be placed outdoor.

In case of indoor format **(T)** or **(OEM)**, both formats, due to its protection degree IP20, will be placed inside the existent control centre, considering that for its correct cooling is needed to have the suitable airflow depending on the model and stated in table 4. **Never install the indoor or (OEM) units in outdoors places.**

Whatever the place is, all formats **is obligatory to be fixed to the wall, inside of the enclosure or floor with parts that guarantee a total and permanent strength** through its respec-tive supports or holes made in its base, see figures 14 to 16.



The forced air cooling flow of the unit is done in the upward way from base and front of the equipment through the highest part. Leave the needed space to make possible the air cir-culation, taking care of the stated parameters.

4.3.- ASSEMBLING OF THE DIFFERENT FORMATS AND VERSIONS.

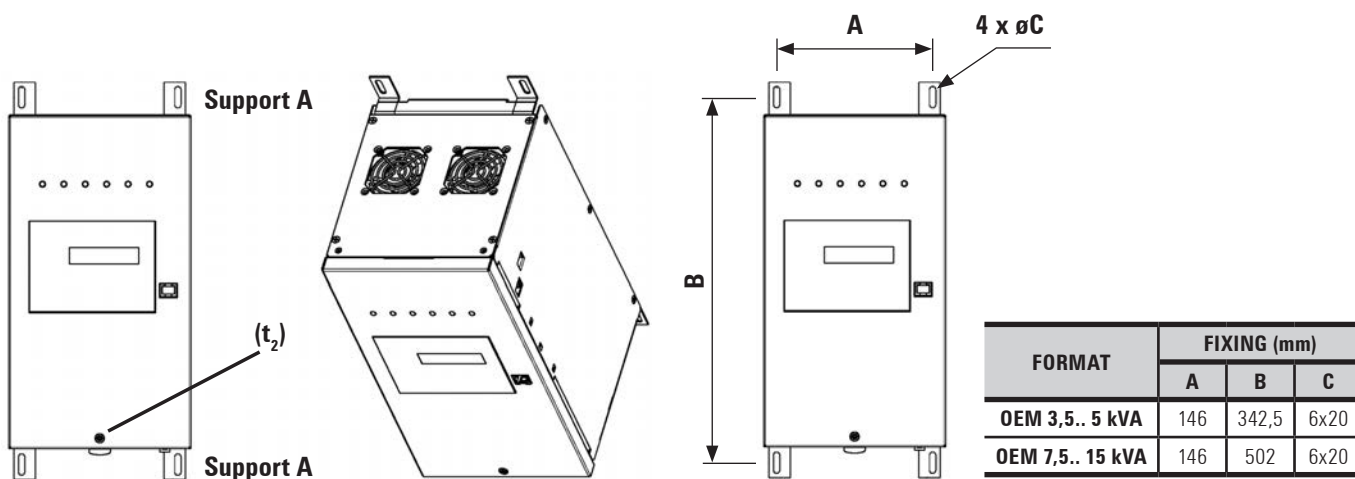

Fig. 14. Module fixing diagram for format (OEM).

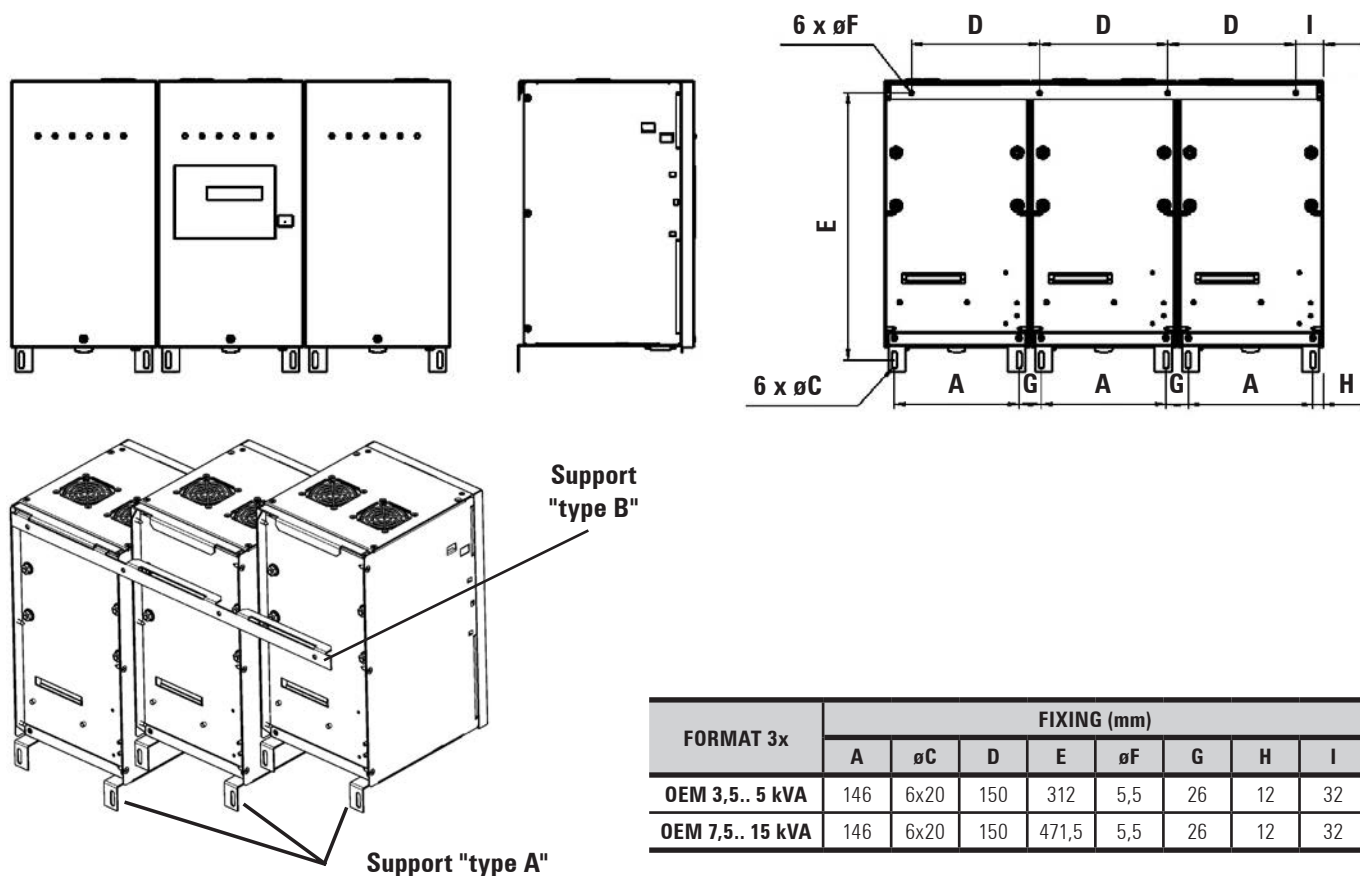
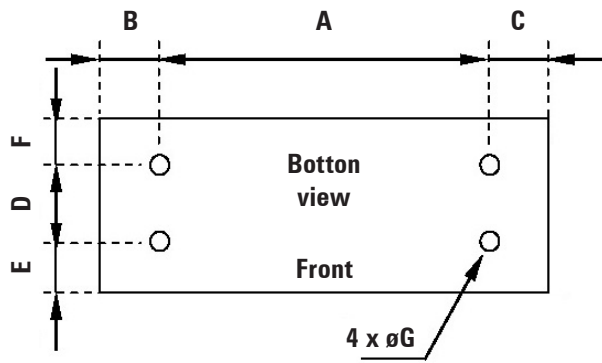
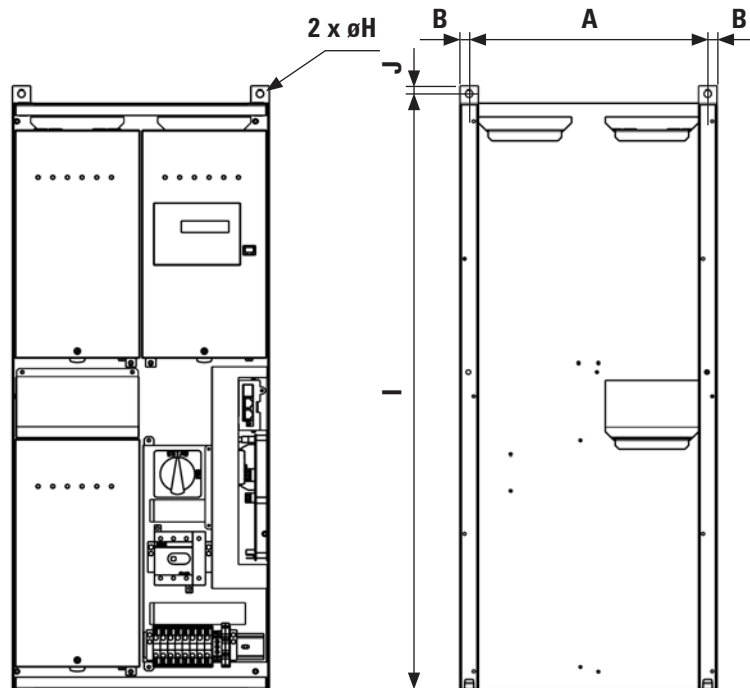
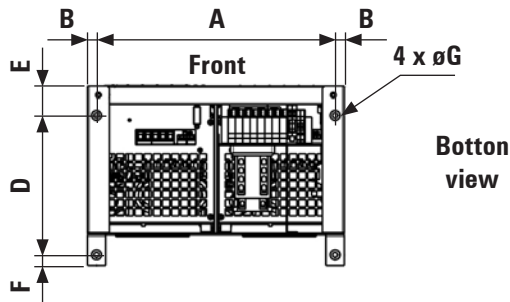

Fig. 15. Fixing diagram for three phase system format (OEM).



Fixing diagram for indoor (T) and outdoor (I) equipments.

FORMAT	FIXING (mm)									
	A	B	C	D	E	F	øG	øH	I	J
T	492	13	13	100	91	42.5	10	-	-	-
I	635	67.5	67.5	195	62.5	62.5	11	-	-	-
TW 7.5.. 15 kVA	325	12.5	-	190	40	15	M8	10	813	10
TW 20.. 45 kVA	325	12.5	-	190	40	15	M8	10	1132	10



Fixing diagram for vertical indoor (TW) equipments.

Fig. 16. Fixing diagram for indoor (T) and outdoor (I) and vertical indoor (TW) equipments.

4.4.- COOLING.

Cooling of equipments with formats (T) and (I):

Lighting flow stabilizer for headline in street lighting **ILUEST+** is a unit of power conversion, so it has heat losses, although they are very low (<4%), they have to be kept in mind for their location. Heat losses due to an efficiency lower than 100%, create heat that has to be dissipated out from the equipment. This is why, the enclosure where the equipment is located, has to allow a flow air cooling that allows the correct cooling of the equipment. These air volumes are stated in table 4 for each power.

The ideal is that the enclosure allows an air inlet through the bottom and air exhausting through the top. Usually is needed that this air exhausting has to be forced by fans in order to create an air depression inside the cabinet. Depending on the closed that the cabinet is and for 45kVA equipments 2 fans of 120x120 supplied at nominal voltage $U_{nominal}$ are enough.

Cooling of modules (OEM):

In case of assembling one module over the other one, keep in mind that the hot air from the lower module does not go inside the top module, in order that it takes fresh air coming from outside of the cabinet. Sometimes, to do it is needed air flow deflectors that modify the hot air flow from one module and avoid heating the other module.

Modules are designed to assemble them in vertical position guiding the air flow from fans upwards and terminal strip to down. In any case, having a suitable cooling, it is possible the horizontal assembling.

Whatever the assembling position were, keep in mind to leave a minimum free space (at least 5cm) in the terminal strip side -to allow the entrance of the cables together with the air flow cooling- and at the fan side for the correct air exhausting and to prevent possible turbulences that brake the fans (>10cm).

MODEL	POWER (kVA)	INDOOR / OUTDOOR	
		Air volume to exhaust m ³ /h /CFM	Heat losses (W)
NE+ 3,5-2	3,5	35 / 21	175
NE+ 5-2	5	35 / 21	250
NE+ 7,5-2	7,5	75 / 44	375
NE+ 10-2	10	75 / 44	500
NE+ 15-2	15	110 / 65	750
NET+ 7,5-4	7,5	100 / 59	375
NET+ 10-4	10	100 / 59	500
NET+ 15-4	15	100 / 59	750
NET+ 20-4	20	220 / 130	1000
NET+ 25-4	25	220 / 130	1250
NET+ 30-4	30	220 / 130	1500
NET+ 45-4	45	320 / 188	2250

Table 4. Cooling air volume and heat losses depending on the modele.

4.5.- RECOMMENDED PROTECTIONS AND CROSS CABLE SECTIONS.

4.5.1.- Recommended protections.

Install protections against overcurrents (overloads and short-circuits), against earth leakage current and overvoltages in accordance with the local regulations. Regarding transient voltages, although the equipment is protected with varistors, it is recommended the use of other methods of protection (like lightning arrestors) if the environment conditions require it.

At the equipment input:

It is recommended a suitable circuit breaker and earth leakage breaker protections (see table 5) at the equipment input. It is advisable that the earth leakage protections are with automatic rearmament to avoid unexpected tripping, due to inrush currents made by storms. The recommended circuit breaker at the input of **ILUEST+** is K characteristic with 4 poles and sizes, stated in table 5.

The earth leakage current of **ILUEST+** is lower than 16 mA (15 kVA module or three phase equipment of 45 kVA). This current can be increased if there were interferences of high frequency or high harmonic tax in mains.

In accordance with ITC-BT09, the current by default, the disconnection threshold of the earth leakage switches, which could be with automatic rearmament, will be of 300 mA as maximum and the earth resistance, measured when commissioning the equipment, will be 30 Ω as maximum. Nevertheless, earth leakage breakers with maximum current of 500 mA or 1 A will be allowed whenever the measured resistance of the earth when commissioning is lower or equal to 5 Ω and 1 Ω , respectively.

4.5.2.- Recommended cross cable sections.

Whatever the installation is (indoor or outdoor), it is recommended to consult the Low Voltage Regulations: ITC-BT-07 - BUILT IN LINES FOR LOW VOLTAGE DISTRIBUTION, in case of Spain, or local regulations in case it is installed out of Spain

Recommended cross cable section:

To connect the equipment, it will be used cables with minimum and maximum cross cable sections stated in table 5 and those cables will be connected through pin terminals or type DIN 46234 depending on the equipment and suitable for the cable section and diameter of the terminal screw stated in table 5 too.

At the equipment output:

It is recommended to protect the output lines by dividing the loads. This way, in case there was a problem in one sector, it will not affect to the total installation. It is strongly recommended to protect them individually, both against overcurrents (overloads and short-circuits), and earth leakage breaker.

ILUEST+ has 40 kA varistors as transient voltage surge suppressors at the input and output. Nevertheless, in some places, with high incidence of lightning, such protection can't be not enough,

Description	Características	NE+ 7,5-4	NE+ 3,5-2 NET+ 10-4	NE+ 5-2 NET+ 15-4	NET+ 20-4	NE+ 7,5-2 NET+ 25-4	NE+ 10-2 NET+ 30-4	NE+ 15-2 NET+ 45-4
		NET+ 7,5-4	NET+ 10-4	NET+ 15-4	NET+ 20-4	NET+ 25-4	NET+ 30-4	NET+ 45-4
Input earth leakage breaker	Sensitivity of 300mA; type A	16 A	16 A	25 A	32 A	40 A	50 A	80 A
Input circuit breaker	4 poles - K characteristic	16 A	16 A	25 A	32 A	40 A	50 A	80 A
Headline contactor	4 poles - 400 V AC3 - coil 230 V ac	16 A	16 A	25 A	32 A	40 A	50 A	80 A
Minimum cross cable section of input mains	RZ1-K	4 mm ²	4 mm ²	6 mm ²	10 mm ²	10 mm ²	16 mm ²	25 mm ²
Maximum cross cable section of input mains	RZ1-K	35 mm ²	35 mm ²	35 mm ²	35 mm ²	35 mm ²	35 mm ²	70 mm ²
Terminals for input cables	Ring terminal DIN 46234	D 6-4 to D 6-35	D 6-4 to D 6-35	D 6-6 to D 6-35	D 6-10 to D 6-35	D 6-10 to D 6-35	D 6-16 to D 6-35	D 8-25 to D 8-70
	For screw	M6	M6	M6	M6	M6	M6	M8
Minimum cross cable section of output mains	RZ1-K	4 mm ²	4 mm ²	6 mm ²	10 mm ²	10 mm ²	16 mm ²	25 mm ²
Maximum cross cable section of output mains	RZ1-K	35 mm ²	35 mm ²	35 mm ²	35 mm ²	35 mm ²	35 mm ²	70 mm ²
Terminals for output cables	Ring terminal DIN 46234	D 6-4 to D 6-35	D 6-4 to D 6-35	D 6-6 to D 6-35	D 6-10 to D 6-35	D 6-10 to D 6-35	D 6-16 to D 6-35	D 8-25 to D 8-70
	For screw	M6	M6	M6	M6	M6	M6	M8
Minimum cross cable section of control line	RZ1-K	2,5 mm ²	2,5 mm ²	2,5 mm ²	2,5 mm ²	2,5 mm ²	2,5 mm ²	2,5 mm ²

1. A three phase mains of 3x380 / 3x400 / 3x415 has been taken.
2. Calculation for equipments with input range of -8%.
3. For switch sizing where the requested characteristic can't be applied, it will fitted in a moulded circuit breaker set as follows:
 - Switch with thermal-magnetic relay.
 - Thermal setting (I_r): stated in table 2.
 - Magnetic setting (I_i): between 4 and 6 times the nominal current.
 - Switch with electronic relay.
 - Thermal setting (I_r): stated in table 2.
 - Setting for protection against phase loosing or unbalancing: 1 (It can be or not this function from manufacturer).
 - Rest of parameters to the minimum.

Table 5. Recommended protections, cross cable section and terminal strips of **ILUEST+**.

then is advisable to use additional protections like lightning arrestors (alone or combined with varistors).

4.5.3.- Installation diagrams.

Figures 17 and 18 show the diagrams of a three phase typical installation of **ILUEST+**, depending it if has or not the optional card BM491* with digital I/O. It is important to meet the following specifications:

- **ILUEST+** has to be **always** installed at the beginning of the lighting line.
- **Manoeuvring:**
 - Headline contactor.

Lighting installations should have contactor to manage the turning on/off of the installation. Such contactor has to be fitted at the input of the lighting flow regulator.

ILUEST+ always has one of its modules with LCD panel, as interface between user and equipment. This LCD panel can make functions of timer and astronomical clock, by control-

ling the start up, saving and nominal levels, and the equipment shutdown.

In order to make possible to turn on/off the equipment, it will be necessary to feed it depending on the option that the equipment has:

- Equipment without control card (BM491*), see figures 19 for single phase equipments or 20 for three phase.

It is necessary to supply the LCD panel through an external power supply provided with the equipment and it has to be connected upstream from contactor. The contactor coil will be managed through a relay located in the LCD panel.
- Equipment with control card (BM491*) with or without manual Bypass, see figures 21 for single phase equipments or 22 for three phase.

The control card (BM491*) supplies the LCD panel and the card incorporates optional SICRES. The contactor coil will be managed through a relay located in the LCD panel.

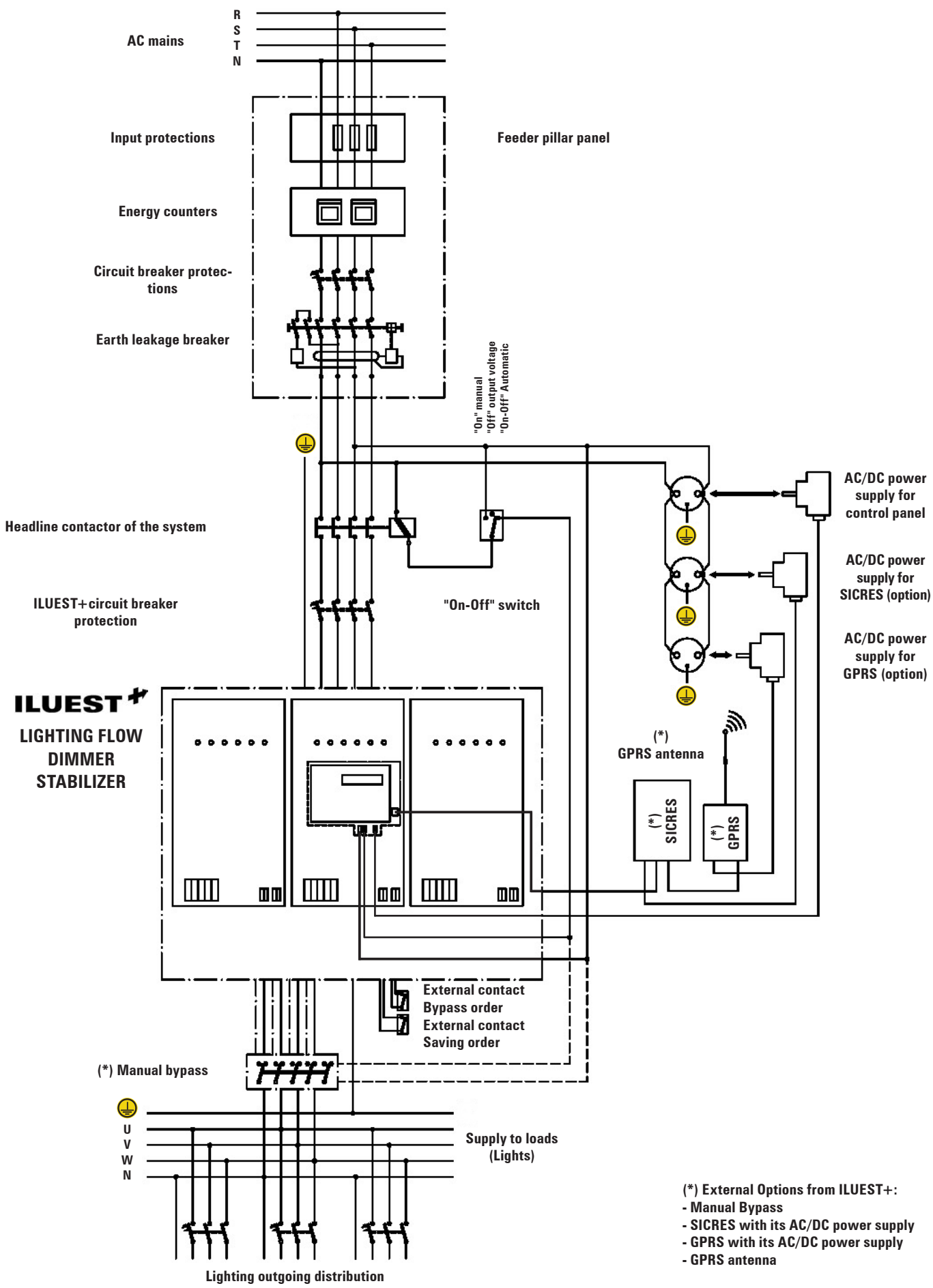

- (*) External Options from ILUEST+:
- Manual Bypass
 - SICRES with its AC/DC power supply
 - GPRS with its AC/DC power supply
 - GPRS antenna

Fig. 17. Typical three phase installation diagram, format (OEM).

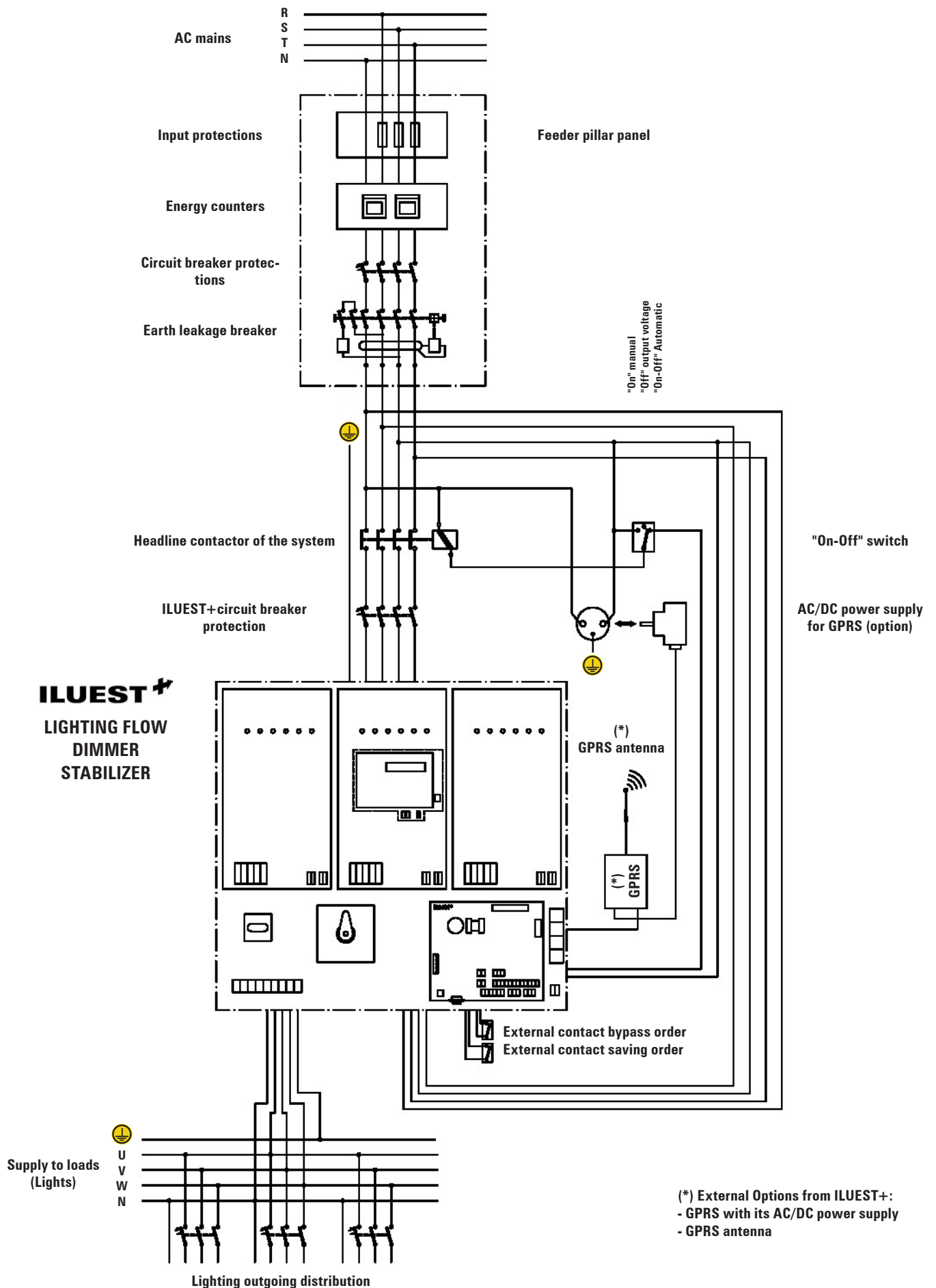

Fig. 18. Typical three phase installation diagram, format (T) or (I) with basic control card BM491*01.

In accordance with ITC-BT09:

- If the system to turn on/off the installation is done through timers or photocells, there will be an additional manual switch (to be fitted in and purchased by the user), which allows the system switching, irrespective of the quoted devices.
- It is recommended to install it downstream from lighting contactor, because this way it is guaranteed that it is turned off when lights are turned off too, and the equipment will not have voltage, avoiding overheating and unnecessary consumptions.

4.6.- WIRING.

Typical circuit diagrams of **ILUEST+** connection can be observed in figures 17 and 18. Respect the wiring, protection and auxiliary control switches strictly than can be appreciated. For single phase equipment, simplify the connection by disregarding the rest of phases.

- To proceed to connect the equipment, open the front door and/or remove the terminal cover of connecting parts, as it is stated in section 4.1.
- Once the connection labour has been finished it is essential to put back all terminal covers until leaving the equipment as it was before starting the process.

4.6.1.- Connecting power supply.

- It is obligatory to earth the equipment through the terminal labelled as (E), making sure that it is done before supplying voltage to the input of the equipment.
- For single phase equipments, connect cables coming from headline contactor of the system, to the input terminals (1_N) and (1_R), by respecting the phase and neutral rotation stated in the labelling of the equipment, and figures 2 and 3 of this manual.
- For three phase equipments, connect cables coming from headline contactor of the system, to input terminals (1_N), (1_R), (1_S) and (1_T), by respecting the phases and neutral rotation stated in the labelling of the equipment, and figures 4 and 5 of this manual.

It is essential the connection of the neutral in any three phase star system, being recognized in the terminals by the label «N».

4.6.2.- Connecting remote control, saving order.

- The **(OEM)** module or control card BM491*, has a terminal strip labelled as «Saving signal». Use a dry contact like a switch, to be installed by the client, between these two terminals to close the circuit and start/remain at saving level. In any three phase system, only act on one of the three modules or own the control card (BM491*).
- Never** apply voltage to this terminal strip, because they are non-potential dry contacts.

4.6.3.- Connecting remote control, Bypass order

- The **(OEM)** module or control card BM491*, has a terminal strip labelled as «Bypass signal». Use a dry contact like a switch, to be installed by the client, between these two terminals to close this circuit and put the equipment on Bypass mode permanently, while the circuit is closed. In any three phase system, only act on one of the three modules or own the control card (BM491*).
- Never** apply voltage to this terminal strip, because they are non-potential dry contacts.

4.6.4.- Connecting output.

- For single phase equipments, connect cables with destination to outgoing distribution, to the output terminals (2_N) and (2_U), by respecting the phase and neutral rotation stated in the labelling of the equipment, and figures 2 and 3 of this manual.
- For three phase equipments, connect cables with destination to outgoing distribution, to the output terminals (2_N), (2_U), (2_V) and (2_W).

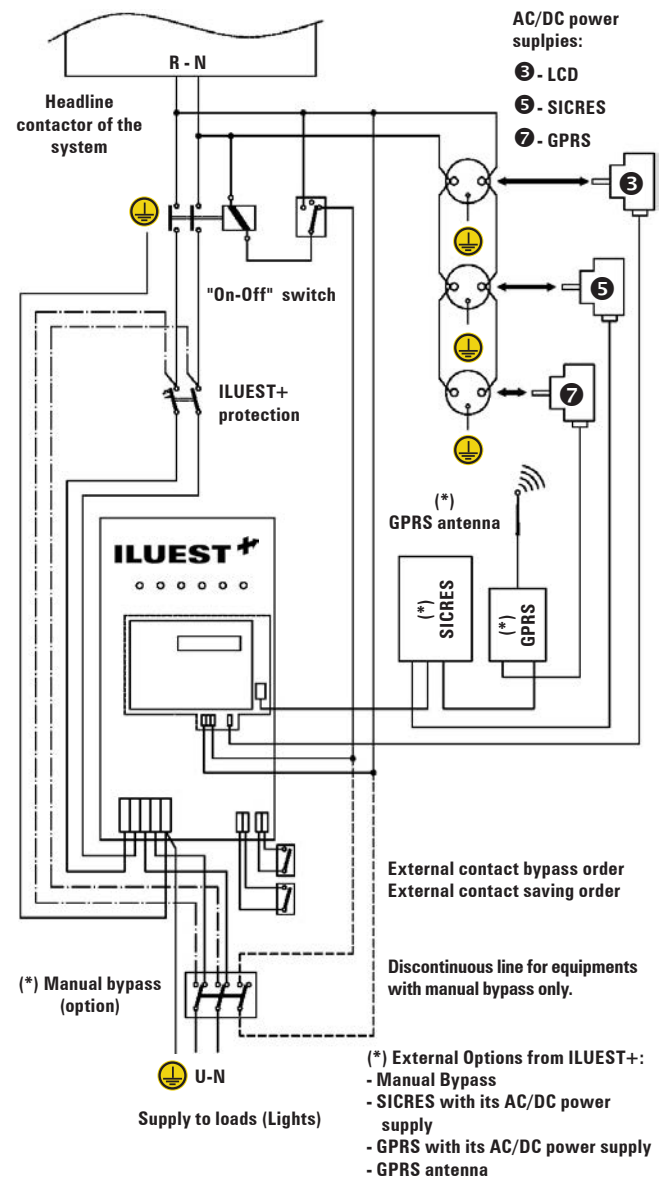

Fig. 19. Installation diagram for single phase format **(OEM)**.

(2_w), by respecting the phase and neutral rotation stated in the labelling of the equipment, and figures 4 and 5 of this manual.

- Both if lighting installation already existed when installing **ILUEST**, and if it were new, make sure about the correct balance of the loads in order to minimize this effect.

- For three phase equipments, take 4 wires (three phases and neutral) coming from mains and before of headline contactor, and connect them to their respective identified terminals over card BM491*, by respecting the phases and neutral rotation (see figure 22).

4.6.5.- Power supply of control card BM491*.

- Control card BM491* is fed through CN1 connector included in itself.
- For single phase equipments, take 2 wires (phase R and neutral) coming from mains and before of headline contactor, and connect them to the identified terminals over card BM491*, by respecting the phase and neutral rotation (see figure 21).

4.6.6.- Connection of the coil of headline contactor.

- Depending if the equipment has the Manual Bypass option, inside or outside to the equipment, the feeding of the coil of headline contactor will be done accordingly (control of headline contactor):

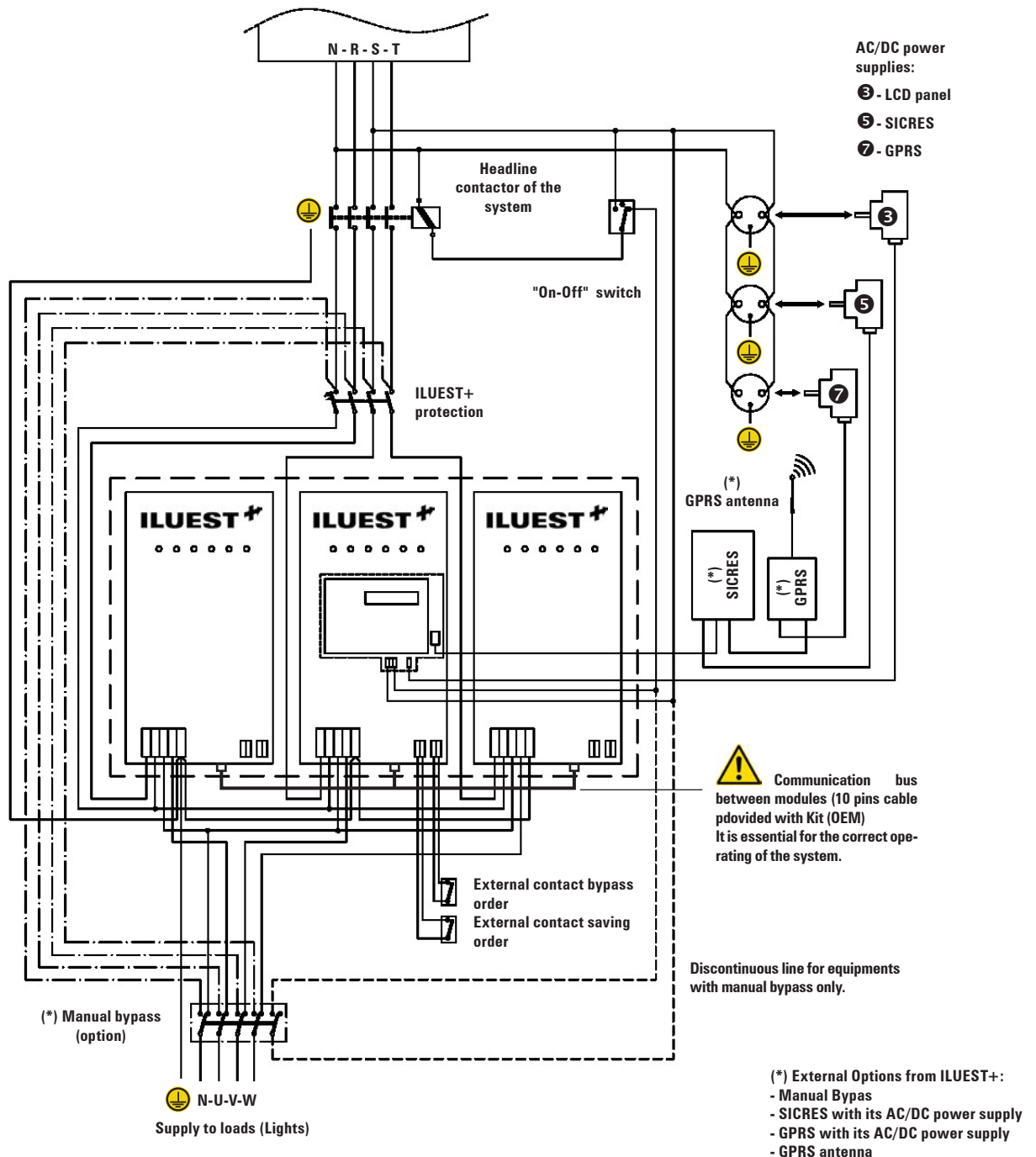

Fig. 20. Installation diagram for three phase equipment with format (OEM).

- ❑ Single or three phase equipment with format **(OEM)**, without neither control card (BM491*) nor manual Bypass (see figures 19 and 20). In these equipments the control of headline contactor, is done through the LCD panel and its power supply through an external AC/DC power supply with transformer provided with the **kit (OEM)**.

Manual Bypass, SICRES card, GPRS with its antenna and their AC/DC power supplies, are optional although they are represented in figures 19 and 20.

When an installation with equipment **(OEM)** has manual Bypass, it is compulsory to make all the connections drawn in discontinuous line in figures 19 and 20.

- ❑ Equipment with format **(T)** or **(I)** with the basic control card BM491*01., or the optional one BM491*00. In these equipments the control of headline contactor, is done through the LCD panel and its power supply it through either of the two controls card BM491* (see figures 21 and 22).

In these equipments manual Bypass is an option that it is provided already built in and it doesn't require any connection as regards of power cables than the ones without this optional. The only difference is that the control of headline contactor is done in a specific terminal strip **(14)** for that purpose, replacing the connections in the control card BM491*.

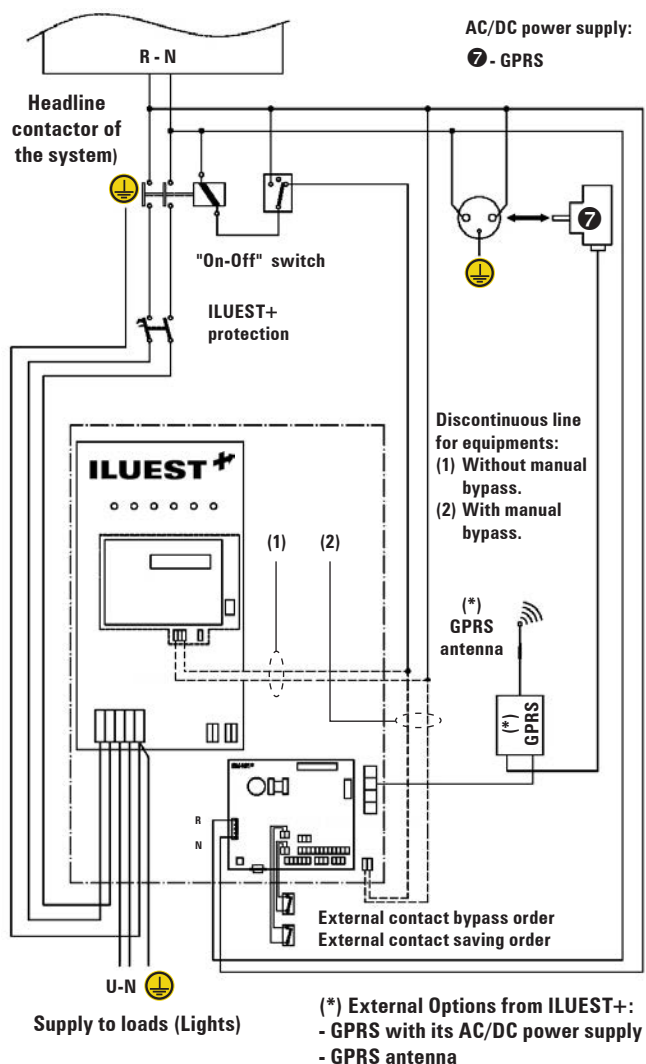

Fig. 21. Installation diagram for single phase unit with format **(T)** or **(I)**.

4.6.7.- Manual Bypass.

- Manual bypass function, both if it is already built in and external to the enclosure is the same. It allows continuing supplying the loads from mains directly during the preventive maintenance tasks or when **ILUEST+** is faulty. It is very useful in indoor and/or tunnel lighting, because it can't be turned off, even during the intervention for testing, checking or replacing. The type of Bypass is make before break, so there is not any break during **ILUEST+** the transference to Bypass and viceversa.
- When manual bypass switch is turned to **position «2» (Bypass mode)**, lamps will always light whatever the position of the input switch of **ILUEST+** is. If you don't want that the lamps light, turn «Off» the protections of switchgear panel previously.
- Attend all the stated connections in section 4.6.6, relating to manual Bypass.

4.7.- SELECTOR FOR ON-OFF AUTOMATIC / START UP (ON), MANUAL / OUTPUT VOLTAGE OFF.

- In accordance with the Low Voltage Electro-technical regulation (ITC-BT-09), if the lighting turning on/off is done with timers and photocells, there will be a manual switch that allows to turn on/off the system, irrespective of the quoted devices. A switch of three positions with more quality performances than the required by the regulations can be observed in figures 17 and 18, to activate the manual function «On», automatic function «On-Off» or output voltage Off (to be fitted in and purchased by the end-user).

4.8.- COMMUNICATION BUS OF MODULES AND PORTS.

- It is essential for the correct operating of a three phase system in format **(OEM)**, to connect the communication bus **(Fc)** (10 pins flat cable), to connectors **(Cb)** of each module. Without doing this connection the LCD panel will be isolated from the rest of modules and it will not be possible to get the measurements and communication.
- Module **(OEM)** of **ILUEST+** with LCD panel, has two different possibilities:
 - ❑ As standard with only one RS-232 communication port in control panel through RJ connector of 6 or 8 pins **(9)** (see figure 23).
 - ❑ And as an option a RS-485 communication port, additional to the first one and supplied through RJ4 connector of 4 pins **(9a)** (see figure 24).

Nevertheless, if it has the control card BM491*, there is a second RS-232 port through DB9 connector (see figure 25). It is not possible to use both RS-232 connections at the same time because it is not a multiconnection channel.

Furthermore control card has another RS-485 port, through RJ4 of 4 pins (see figure 24).

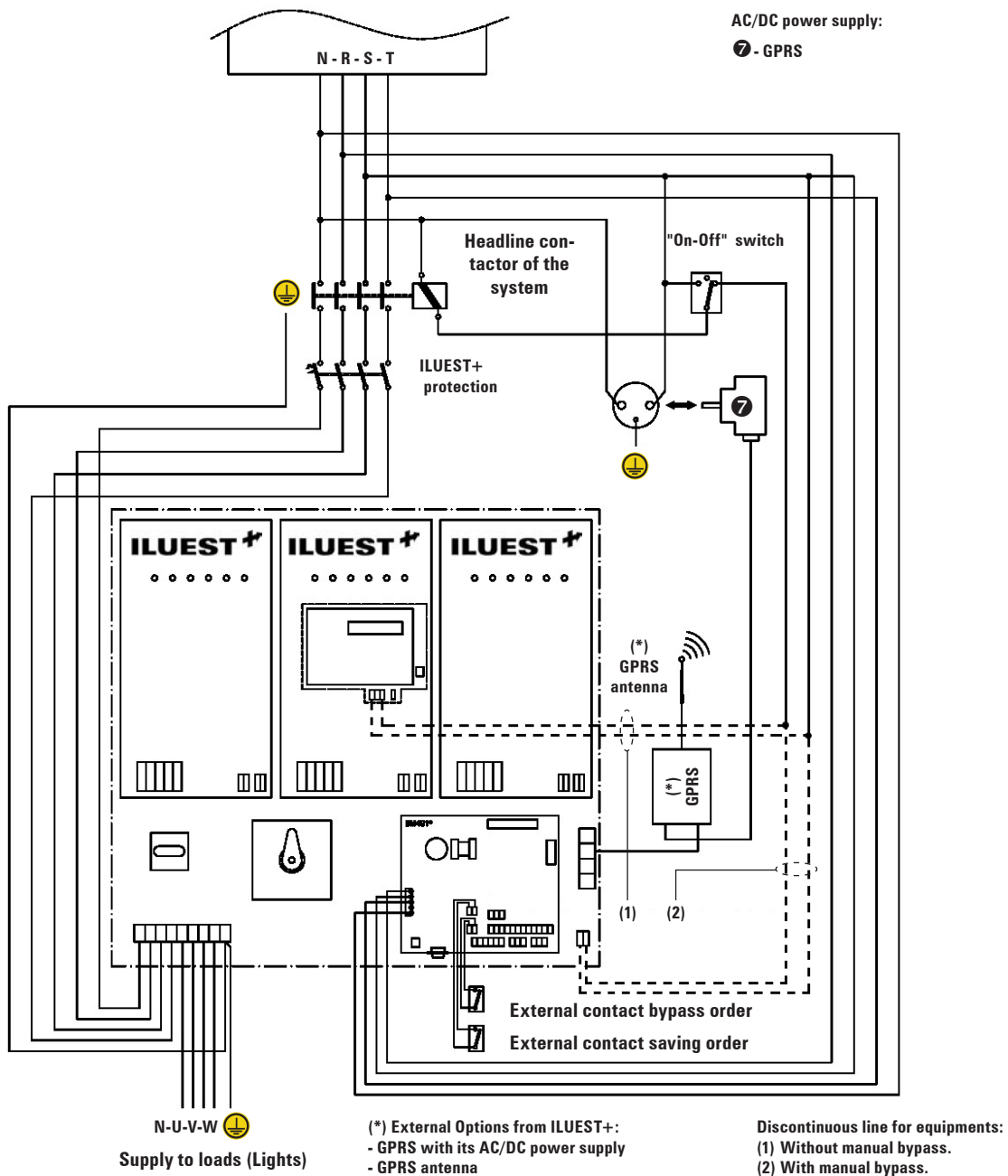
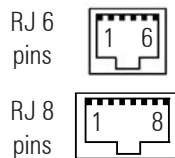

Fig. 22. Installation diagram for three phase equipment with format (T) or (I).

Reference	Nr pins RJ 6	Nr pins RJ 8
GND	1	4
TXD	5	5
RXD	6	6



Reference	Nr pins DB9
CD	1
RXD	2
TXD	3
DTR	4
GND	5
RTS	7
CTS	8
RI	9

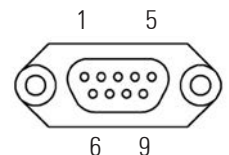

Fig. 23. RJ connector for RS-232 (9).

Reference	N° pins RJ 4
EXT-DO/RI	2
EXT-DO/RI	3
100R-GNDC	4

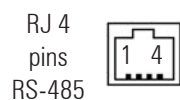
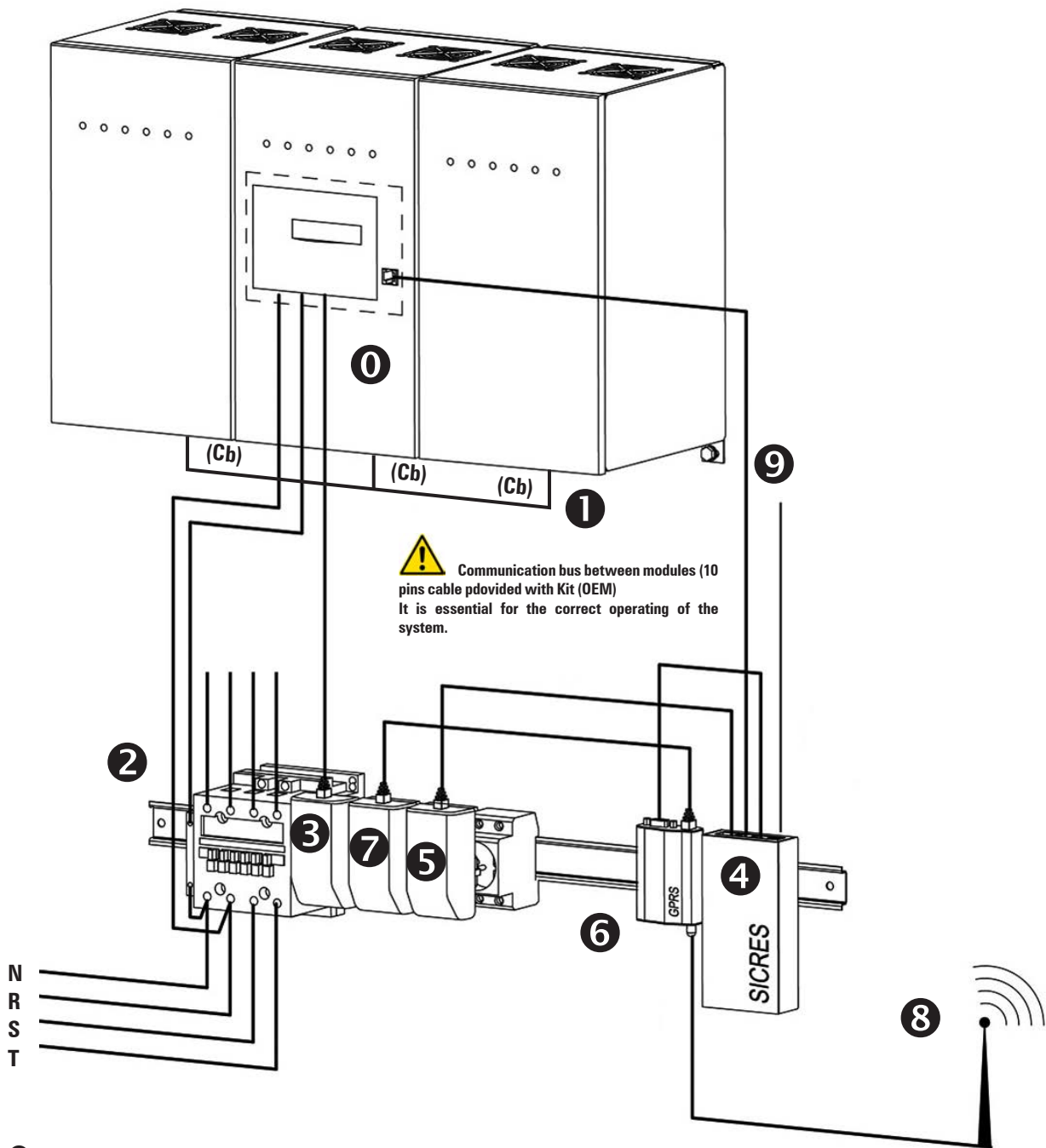



Fig. 24. RJ connector for RS-485 in card BM491*.

Fig. 25. DB9 connector for RS-232 in card BM491*.



- ① Module (OEM) with LCD panel -master module-.
- ① Communication bus between modules (10 pins cable with three connectors (Cb)).
- ② Headline contactor of the installation, located in feeder pillar panel (user's property).
- ③ AC/DC transformer power supply for control panel with LCD.
- ④ SICRES card (Optional).
- ⑤ AC/DC transformer power supply for SICRES card. Supplied with SICRES card.
- ⑥ GSM/GPRS modem (Optional).
- ⑦ AC/DC transformer power supply for GSM/GPRS. Supplied with GSM/GPRS modem.
- ⑧ Antenna for GSM/GPRS modem. Supplied with the optional.
- ⑨ Ethernet connection.

 The feeding of synoptic through the AC/DC transformer power supply in equipments (OEM), is essential for the correct operating of the LCD panel, the timer and/or the astronomical clock, whatever the equipment is, single or three phase.

 For those equipments (OEM) without the stated optionals, omit the respective connections.
 For single phase equipments (OEM), all connections have to be done relating to the optionals, as a three phase equipment were (like the above figure) and when it has them.

Fig. 26. Three phase equipment (OEM) simulating connection with SICRES and GPRS options.

5.- OPERATING.

5.1.- START UP AND SHUTDOWN.

5.1.1.- Controls before starting up.

Before starting up the system, there are some settings and checking that have to be done:

- Check the correct connection of mains and loads, according to the procedures described in previous chapter.
- In case of existing any optional already installed, check its correct connection and setting before proceeding to start up the equipment (see specific user's manuals).
- Turn on the input voltage to the equipment (input protections to «On» and manual selector to «Automatic»).

5.1.2.- Start up.





- The equipment starts up when the headline contactor is turned on and it is shutdown when the contactor is turned off. This contactor can be managed by the equipment itself, through the control of LCD panel or managed by an external part out from the equipment (photoelectric cell, timer, external astronomical clock, as well as manual control).
- Connect the power supply to equipment through the input switch **(4)** to «0» or «Off» position (it is available in formats **(T)** and **(I)** only) and loads should be disconnected. Check the correct input voltage V_{in} .
- Turn «On» or «I» the input switch **(4)** (it is available in formats **(T)** and **(I)** only). Check the correct output voltage.
- Turn off the general input switch from switchgear panel and connect the loads.
- Turn on the general input switch from switchgear panel.
- Now the loads are supplied. The start up and shutdown of the system is done when turning on/off the headline contactor of the installation, respectively, not being necessary any daily operating, because it is completely automatic: each day it will start up or shutdown when the headline contactor of lighting is turned on/off, and the saving order will be activated or cancelled according to the external setting of the astronomical clock or timer, as it is described in sections 4.6.2 and 4.6.3.



Any daily automation can be modified when needed, just changing the position of the required switch in accordance with the low voltage electro-technical regulation (ITC-BT-09) or the suggested switch.

- To start up/ shutdown the equipment, in automatic position and the equipment is provided with the headline contactor connected as it is shown in figures from 19 to 22, can be done through the LCD panel (see screen map screen of LCD Fig. 29):
 - Starting from screen 0.1, press 7 times the advance key () till reaching screen 7.1. «TIME SCHEDULER» and press once the key



() , to go to screen 7.2. «Activate Time scheduler (YES)».

- When time scheduler is active (by selecting (YES)), the equipment will start up and shutdown according to the setting automatically. If the unit is inside the operating period, the equipment will turn on the contactor and if it is out from the operating period, it will be turned off.
- In this situation (when time scheduler is active but the current time is out from the start up setting), if the contactor is activated manually, **ILUEST+** modules will be fed but they will remain on Bypass.
- If time scheduler is deactivated by selecting (NO), the headline contactor will be turned off.
- To select (YES) or (NO), starting from screen 7.1 «TIME SCHEDULER», press key () and the indicator (NO) or (YES) will blink and it will be able to set by means of key () to change from (YES) to (NO) and key () to change from (NO) to (YES) and () to validate the selection.

5.1.3.- Complete shutdown of the equipment.

- A complete and manual shutdown will only have sense for **corrective (faults) or preventive maintenances of the equipment, because in normal conditions the shutdown will be totally automatic and neglected through the headline contactor.**
- Turn «0» or «Off» the input switch **(4)** (available in formats **(T)** or **(I)** only).
- Turn off the previous circuit breaker to the equipment in case you want to break its power supply.

5.1.4.- Manual Bypass.

- Manual bypass function, both if it is already built in and external to the enclosure is the same. It allows continuing supplying the loads from mains directly during the preventive maintenance tasks or when **ILUEST+** is faulty. It is very useful in indoor and/or tunnel lighting, because it can't be turned off, even during the intervention for testing, checking or replacing. The type of Bypass is make before break, so there is not any break during **ILUEST+** the transference to Bypass and viceversa.
-  When manual bypass switch is turned to **position «2» (Bypass mode)**, lamps will always light whatever the position of the input switch of **ILUEST+** is. If you don't want that the lamps light , turn «Off» the protections of switchgear panel previously.
-  When manual bypass switch is returned back to **position «1» (ILUEST mode)**, lamps will be fed from **ILUEST+**, on condition that the input switch is in position «On».

5.2.- OPTICAL LED INDICATORS.

Figure 27 shows the layout of the optical indicators per phase, and they light when its function is activated.

- (a) Red led indicator «Bypass». It lights when Bypass is activated, due to fault, overload, manual or software activation and or shifting to Manual Bypass mode.
- (b) Red led indicator «Alarm». It lights with any alarm of table 6, although the equipment doesn't have LCD panel because the alarms do not depend on the own LCD panel, they depend on the control of the equipment.
- (c) Green led indicator «Status». Nominal to «On», Saving to «Off» and equipment on ramp it blinks.
- (d) Yellow led indicator «Communications». Blinking means it communicates.
- (e) Yellow led indicator «Local Bypass». It lights when bypass order is activated through the module **(OEM)** or through the control card (BM491*) in formats **(T)** or **(I)**.
- (f) Yellow led indicator «Local saving». It lights when saving order is activated through the module **(OEM)** or through the control card (BM491*) in formats **(T)** or **(I)**.

5.3.- SETTINGS.

- Settings for end-user are the **ILUEST+** parameters. To check or change the preset values in order to adapt the equipment to the installation, go to screen 10.1 (0000) NORMAL and enter the user password. To do it, proceed as follows:
 - Starting from screen 0.1, press 10 times advance key (➡) till reaching screen 10.1.
 - Press (ENT).
 - Characters will blink.
 - Press keys (↵) or (↶) to change the value and keys (➡) or (↶) to change the character till entering the password (0500).
 - Press (ENT) to confirm.
- Once the entered password is correct, (0500) PROGR., there will be access to change/set the **ILUEST+** parameters. To do it and starting from screen 0.1, press 5 times advance key (➡) till reaching screen 5.1 «ILUEST PARAMETERS» (see screen map of LCD Fig. 17).
- Press key (➡) to go to screen 5.2 «TYPE OF SETTING». From this screen the settings can be selected to (GLOBAL), same setting for all modules or (INDIVIDUAL), different setting for each module.

To select (GLOBAL) or (INDIVIDUAL) press key (ENT) from screen 5.2 «TYPE OF SETTING», and (GLOBAL) or (INDIVIDUAL) will blink. To change the selection, use key (➡) or (↶) to jump between them and (ENT) to confirm the selection.

In case (INDIVIDUAL) was selected, the module to set has to be selected to (1 (R), 2 (S) or 3 (T)) in each one of the parameters by pressing (ENT).
- When selecting the type of lamp in screen 5.3. **ILUEST+** will

set all the preset parameters from factory for this kind of lamp. Once the type of lamp is selected, any parameter can be set (start voltage, duration of starting status, nominal voltage, saving voltage1, saving voltage2) in order to be customized to the installation.



Fig. 27. Optical indicators (leds) on control panel with LCD.

6.- CONTROL PANEL WITH LCD.

6.1.- DEFINITION OF KEYBOARD AND ITS OPERATING.

LCD panel (see figure 27).

- (ENT) Key «ENTER».
- (ESC) Key «ESC».
- (↑) Key to move up (return).
- (↓) Key to move down (advance).
- (→) Key to move to right.
- (←) Key to move to left.

6.2.- BASIC FUNCTIONS OF KEYBOARD FROM SYNOPTIC.

- Through keys advance (↓) and return (↑), there is access to all the menus of the LCD panel, being able to move from one to another with themselves.
- Through keys right (→) or left (←), there is access to the screens of all the submenus of the LCD panel, being able to move from one to another with themselves.
- Key (ENT), has different purposes depending on the menu we are:
 - Submenu entry. Press key (ENT) to activate the function setting, the figures in the screen blink. With keys (→) - (←) the character to set is selected and with keys (↓) - (↑) the value is selected. To confirm press (ENT). Next field will blink, to continue doing settings proceed in the same way or press (ESC) to escape.
 - Validation of measurements or parameters.
- When pressing key (ESC) from any screen of any submenu, we go back to main screen (Screen 0.1), unless we are inside of any screen from «Parameters» menu and changing any of them. Then the first pulsation of key (ESC) will be to stop blinking the value and the second one to go back to main screen.
- Notes related with the screen map of figure 29:
 - Some screens has a determined quantity of «→» characters. Each one of it, means one character so the maximum length of the field will be determined by the quantity of them.
 - Each screen is labelled with a number located in its right bottom corner. It is only included as a mere reference for its next description and explanation.
 - Other note (*1), means the hidden programming screens through the password (0500) in «screen 10.1». This safety level avoids that non-authorized staff can alter or modify any setting.

6.3.- SCREEN DESCRIPTION.

6.3.1.- Main screen «Start».

Screen 0.1

Basic screen, which is displayed when the equipment is started up. It shows the time, date and equipment status. It is also the displayed screen when pressing (ESC) to escape from any menu or submenu of LCD panel.

Screen 0.2

It allows activating or deactivating the Saving and /or Manual shut-down orders, so it modifies the status of the equipment.

Screen 0.3

It displays the status of the communications for each module/phase:

- 0 = It doesn't communicate.
- 1 = It communicates.
- and the quantity of modules that it is communicating is displayed in the right bottom corner.

6.3.2.- Menu «Measurements» (Screen 1.1).

To go from main screen press once the advance key (↓). By means of key (→) there is access to all the screens of submenus, being able to move from one to another with the keys (→) or (←).

The figure on top right corner of each submenu means the address of the module that they belong to. Each module has determined number: 1 phase R, 2 phase S and 3 phase T.

To display the measurements of that module, press (ENT), select the module address with keys (↓) or (↑) and confirm with (ENT). Next press (ENT) to escape and press (↓) to go back to menu «Measurements».

Screen 1.2

Submenu for input voltage and frequency.

Screen 1.3

Submenu for output voltage and current supplied to the load.

Screen 1.4

Submenu for apparent power (kVA) and active (kW) supplied to the load, as well as its type (Resistive, L = Inductive, C = Capacitive) with its power factor.

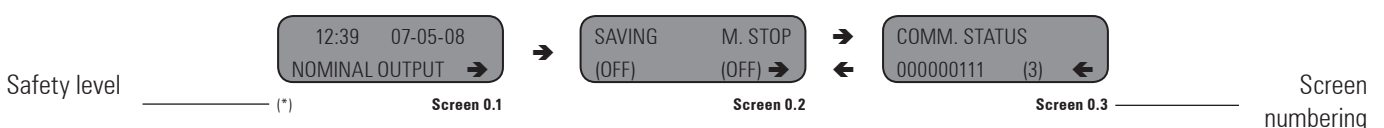

Fig. 28. Reference annotations over the screens.

Screen 1.5

Submenu for percentage of load and saving, which is done depending on the input and output voltages.

Screen 1.6

Submenu for temperatures of inductor (IND) and heatsink (D). Depending on the power of the equipment there will be one heatsink only, so one figure will be displayed in negative.

Screen 1.7

Submenu for firmware version of control module.

6.3.3.- Menu «Alarms» (screen 2.1).

To go from main screen press twice the advance key (⏩). By means of key (➡) the most recent active alarm is displayed, being able to move from one to another inside of the alarm list with the keys (➡) or (⬅).

If there is not any alarm, it will not possible to go forward with key (➡).

Figure 29 is showing just only one alarm as an example, but there could be some of them, the active ones and ordered by appearance order. In table 6, there are all the possible alarms displayed in the LCD panel.

Screen 2.2

Example: Active alarm and quantity of modules that they have it.

Representation in LCD panel	Description
OVERLOAD	Output overload alarm
BYPASS	Bypass alarm
INPUT V. LOW	Low input voltage alarm
INPUT V. HIGH	High input voltage alarm
OUTPUT V. LOW	Low output voltage alarm
OUTPUT V. HIGH	High output voltage alarm
TEMP. 1 HIGH	High temperature 1 alarm (heatsink)
TEMP. 2 HIGH	High temperature 2 alarm (choke)
P. DEVICE ERR. 1	Serial IGBT desaturation
P. DEVICE ERR. 2	Parallel IGBT desaturation
BYPASS FAIL	Bypass fault alarm
FAN FAILURE	Fan fault alarm
ILUEST BLOCKED	Equipment blocked alarm
MANUAL BYPASS	Manual bypass alarm
GENERAL ALARM	General alarm

Table 6. Alarm list displayed in the LCD panel.

6.3.4.- Menu «Data logger» (Screen 3.1).

To go from main screen press three times the advance key (⏩). By means of key (➡) there is access to all log screens starting from the most recent one (maximum 200 logs) and being able to move from one to another with the keys (➡) or (⬅).

In case of no logs, it will not be possible to move forward with key (⏩).

Screen 3.2

It allows to clear the event data logger.

Screen 3.3

Example of an event log of the equipment: day (mm/yy), if the alarm has been activated or deactivated (ACT/DES), address of the affected module (M:), time of the alarm (hh:mm).

6.3.5.- Menu «General parameters» (Screen 4.1).

To go from main screen press four times the advance key (⏩). By means of key (➡) there is access to all the screens of general parameters, being able to move from one to another with the keys (➡) or (⬅).

Screen 4.2

Regarding to the clock of the equipment. It can be set, considering its structure (hh:mm:ss), set the summer time (DST) or out from summer time (-), set the day (dd:mm:yy) and weekday.

Screen 4.3

The contrast of the LCD panel can be set for an optimal visualisation.

Screen 4.4

Language setting: Spanish, English.

Screen 4.5

Regarding to communication parameters with **ILUEST+** modules.

Screen 4.6

Regarding to external communication parameters through RS-232.

Screen 4.7

Regarding to external communication parameters through RS-485.

6.3.6.- Menu «ILUEST+ parameters» (Screen 5.1).

All the screens of this menu are hidden by default and a password has to be entered (0500) in «**screen 10.1**» to make any setting. This safety level allows that non-authorized staff makes any setting or modify any preset values.

To go from main screen press five times the advance key (⏩). By means of key (➡) there is access to all the screens of programming parameters of **ILUEST+**, being able to move from one to another with the keys (➡) or (⬅).

Screen 5.2

A GLOBAL setting can be selected for all the modules together, or INDIVIDUAL, one by one. When GLOBAL setting is selected, it operates over the LCD control panel application, when INDIVIDUAL is selected, it operates over the resident application in each control of each module of the equipment.

Screen 5.3

Preset parameters for each type of lamp (high pressure sodium HP, low pressure sodium LP, high pressure mercury HP, low pressure mercury LP (fluorescents) and metal halide). When selecting any type of lamp a preset values for nominal start voltage and saving voltage are uploaded.

Screen 5.4

Voltage and duration in start status. Any parameter can be set individually, to adapt them to the installation needs.

Screen 5.5

Nominal and saving voltages. Any parameter can be set individually, to adapt them to the installation needs.

Screen 5.6

Saving level (voltage) 2. The parameter can be set to adapt it to the installation needs.

Screen 5.10

By means of this screen, the INDIVIDUAL mode of setting can be selected, so it allows to set the parameters per each module independently (1, 2 or 3) corresponding to phases R-S-T:

- Start voltage and duration of itself (Screen 5.11).
- Nominal and saving voltages (Screen 5.12).
- Saving level (voltage) 2 (Screen 5.13).

6.3.7.- Menu «Relay setting» (Screen 6.1).

All the screens of this menu are hidden by default and a password has to be entered (0500) in «**screen 10.1**» to make any setting. This safety level allows that non-authorized staff makes any setting or modify any preset values.

To go from main screen press six times the advance key (⏩). By means of key (➡) there is access to all the screens of relay setting of control card BM491*, being able to move from one to another with the keys (➡) or (⬅).

Screen 6.2 to 6.9

A relay from card BM491* can be associated to any alarm, so when the alarm is active the associated relay is activated too.

6.3.8.- Menu «Time scheduler» (Screen 7.1).

To go from main screen press seven times the advance key (⏩). By means of key (➡) there is access to all the screens of time scheduler, being able to move from one to another with the keys (➡) or (⬅).

Time scheduler can be activated in order to make automatic the daily start up and shutdown, as well as the shifting to saving or nominal. The daily setting can be done for all the weekdays or can be customized for any particular weekday.

Also, the start up and shutdown can be selected to be activated by the astronomical clock, this way it will never be a fix time because it will depend on the season of the year (the astronomical clock calculates the sunrise and sunset for each day of the year, depending on a geographical coordinates).

Screen 7.2

Time scheduler activation can be selected, to activate (YES) or to not activate (NO). When selecting YES, the equipment starts up and shutdown and shift to saving and nominal automatically.

Screen 7.3

It is possible to select the weekdays with a determined programming: each weekday, from Monday to Friday, Saturday and Sunday, Monday to Sunday, and 10 special days. It can be selected the days and special days that are affected by the programming. Duty cycle is SIMPLE, which means On (start up to nominal) - Saving 1 - Nominal - Off (out of service).

Screen 7.4

Astronomical clock can be activated (YES/NO) in order to make variable the start up and shutdown of the equipment depending on the day duration and according to the season of the year.

Screen 7.5

Time when it will start up (in case the astronomical clock were NOT active) and time when it will shift from Nominal to Saving 1.

Screen 7.6

Time when it will shift from Saving 1 to Nominal and time when it will be shutdown (in case the astronomical clock were NOT active).

Screen 7.10

It is possible to select the weekdays that will follow a determined programming, each weekday, from Monday to Friday, Saturday and Sunday, Monday to Sunday, and 10 special days. It can be selected the days and special days that are affected by the programming. Duty cycle is DOUBLE (1), which means On (start up to nominal) - Saving 1 - Saving 2 - Saving 1 - Nominal - Off (out of service).

Screen 7.11

Astronomical clock can be activated (YES/NO) in order to make variable the start up and shutdown of the equipment depending on the day duration and according to the season of the year.

Screen 7.12

Time when it will start up (in case the astronomical clock were NOT active) and time when it will shift from Nominal to Saving 1.

Screen 7.13

Time when it will shift from Saving 1 to Saving 2 and time that it will shift from Saving 2 to Saving 1.

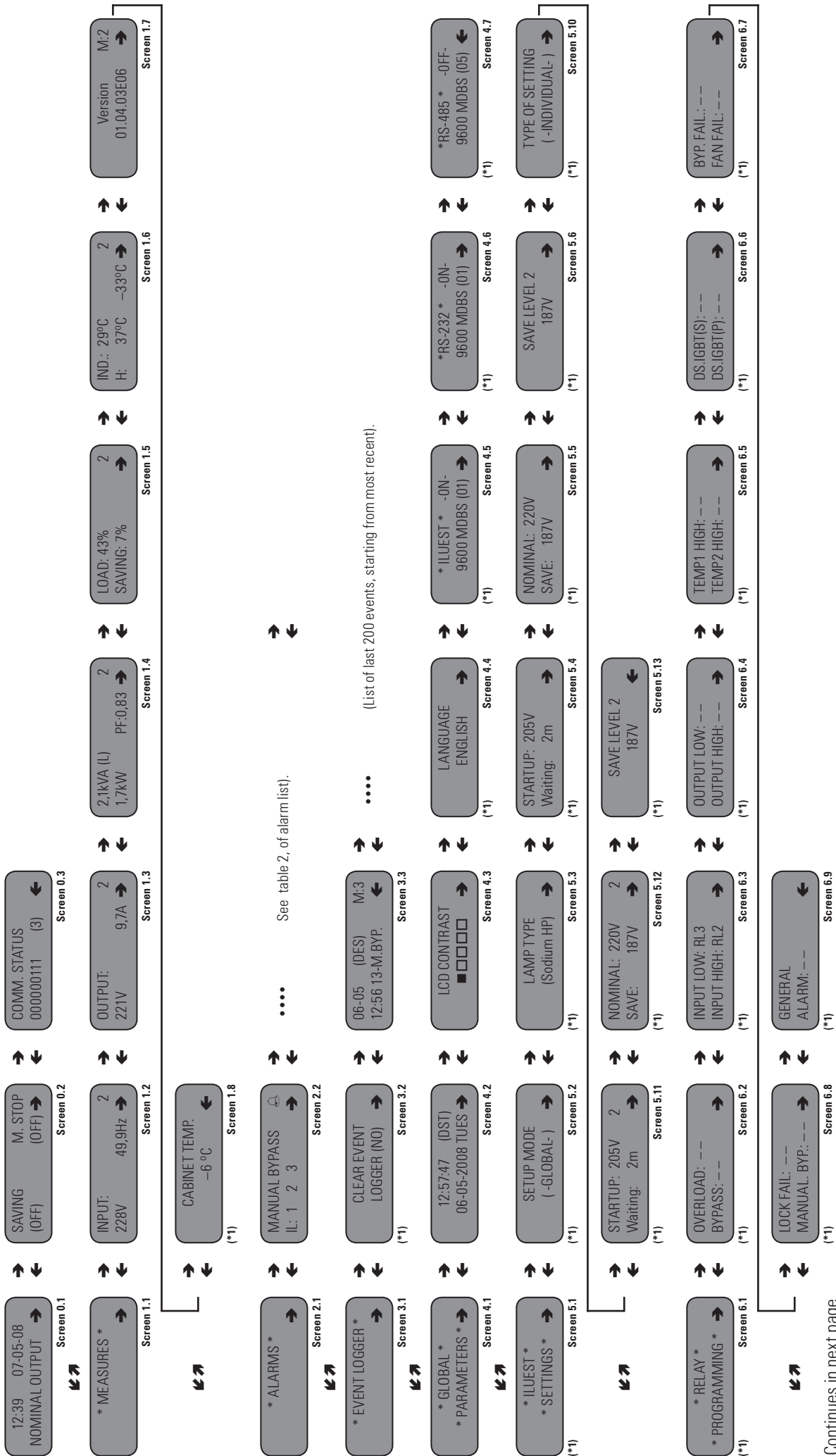

(List of last 200 events, starting from most recent).

See table 2, of alarm list.

Continues in next page (see screen 7.1).

Comes from previous page (see screen 6.1).

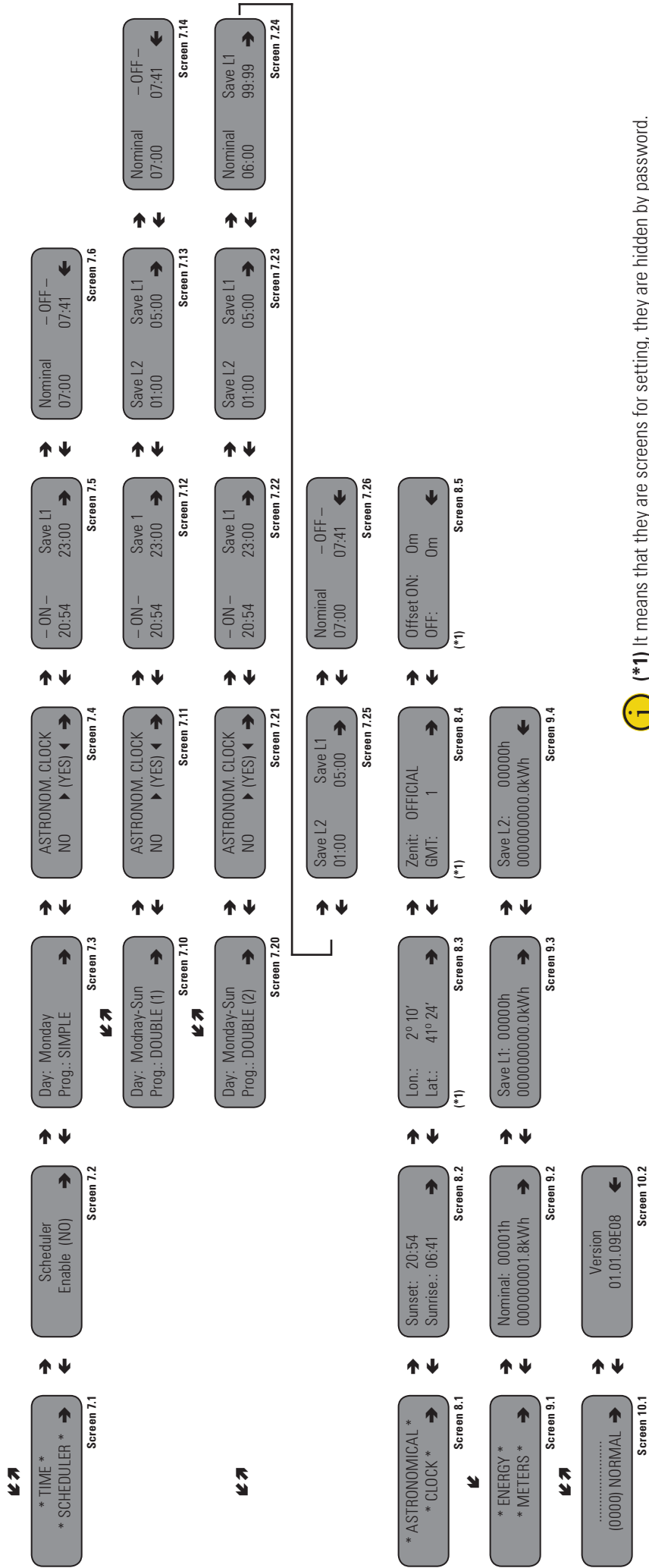

i (*1) It means that they are screens for setting, they are hidden by password.

Fig. 29. Screen map of LCD panel.

Screen 7.14

Time when it will shift from Saving 1 to Nominal and time when it will be shutdown (in case the astronomical clock were NOT active)

Screen 7.20

It is possible to select the weekdays that will follow a determined programming, each weekday, from Monday to Friday, Saturday and Sunday, Monday to Sunday, and 10 special days. It can be selected the days and special days that are affected by the programming. Duty cycle is DOUBLE (2), which means to make two consecutive time DOUBLE (1) program without going Off.

Screen 7.21

Astronomical clock can be activated (YES/NO) in order to make variable the start up and shutdown of the equipment depending on the day duration and according to the season of the year.

Screen 7.22

Time when it will start up (in case the astronomical clock were NOT active) and time when it will shift from Nominal to Saving 1.

Screen 7.23

Time when it will shift from Saving 1 to Saving 2 and time that it will shift from Saving 2 to Saving 1.

Screen 7.24

Time when it will shift from Saving 1 to Nominal and time when it will shift from Nominal to Saving 1.

Screen 7.25

Time when it will shift from Saving 1 to Saving 2 and time that it will shift from Saving 2 to Saving 1.

Screen 7.26

Time when it will shift from Saving 1 to Nominal and time when it will be shutdown (in case the astronomical clock were NOT active).

6.3.9.- Menu «Astronomical clock» (Screen 8.1).

All the screens of this menu are hidden by default and a password has to be entered (0500) in «**screen 10.1**» to make any setting. This safety level allows that non-authorized staff makes any setting or modify any preset values.

To go from main screen press eight times the advance key (⏩). By means of key (➡) there is access to all the screens of astronomical clock, being able to move from one to another with the keys (➡) or (⬅).

Screen 8.2

Sunset and sunrise. Data calculated by the astronomical clock, depending on the geographical location that the equipment is installed (entered values in screen 8.3) day of the year and GMT (value in screen 8.4).

Screen 8.3

Geographical location of the city or town where **ILUEST+** is in-

stalled. The geographical coordinates of longitude and latitude in degrees and seconds can be obtained from a GPS, map, Internet,.... and entered in this screen.

Screen 8.4

Time zone as regards Greenwich Meridian. Select zenith: OFFICIAL, CIVIL, NAUTICAL or ASTRONOMICAL.

GMT (Greenwich Meridian Time): In Spain the time referred to GMT is GMT+1.

Screen 8.5

Offset (positive or negative delay) to start up «On» and shutdown «Off» ILUEST+. A value can be entered to put forward or delay some minutes, the start up and/or shutdown of the equipment therefore the lighting too



Relating to zenith: Official, civil, nautical or astronomical.

Generally Sunrise and Sunset are referred to the moment when the solar ring is over the horizon. So, we have to consider the semi-diameter of the sun ring, which has 16 minutes of arch.

So, the sunrise and sunset happen when the sun has an altitude of $-0^{\circ}50'$ (34' for refraction, and plus 16' for semi-diameter of the ring). It is the **official twilight**.

Meanwhile the atmosphere reflects the solar light, the sky is not dark instantly during the sunsetting. During the **civil twilight**, there is enough light to make activities outside; it happens meanwhile the altitude of the sun is -6° .

During the **nautical twilight**, there is enough darkness to see the most brilliant stars, but not enough light to see the horizon, activating the browsers to measure the stellar altitudes; it happens meanwhile the altitude of the sun is -12° .

During the **astronomical twilight**, the sky still has too much light to make reliable astronomical observations; it happens meanwhile the altitude of the sun is -18° .

Once the sun is below 18° relating to horizon, we talk about **astronomical darkness**. The same twilight diagram is repeated, to the other way with the sunrise.

In summer, the astronomical twilight is prolonged all night long in those places that its latitude overcomes the 49° .

Recommendation: For a normal use of **ILUEST+** astronomical clock, it is recommended to put the option «Zen» to «Off» (**Official**).

6.3.10.- Menu «Energy counters» (Screen 9.1).

To go from main screen press nine times the advance key (⏩). By means of key (➡) there is access to all the screens of energy counters, being able to move from one to another with the keys (➡) or (⬅).

This menu allows checking the operating time in each status (Nominal, Saving 1 and Saving 2), as well as the accumulated consumptions in kWh of each one.

Screen 9.2

Number of hours and accumulated kWh with the equipment in Nominal status

Screen 9.3

Number of hours and accumulated kWh with the equipment in Saving 1 status.

7.- MAINTENANCE, WARRANTY AND SERVICE.

7.1.- BASIC MAINTENANCE GUIDE.

Main directives for a correct maintenance are alike to those ones made by our Service and Technical Support when making the **Pre-ventive** maintenance (see section 7.5).

7.2.- TROUBLESHOOTING GUIDE (F.A.Q.).

In case of wrong operating of the equipment, and before contacting with the Service and Technical Support (**S.T.S.**), the user should try to solve the problem with its own means, if the symptoms are one of the followings:

7.2.1.- If the equipment doesn't start up.

Check:

- Input voltage is correct. Otherwise:
 - Check that the protections of the installation are turned «On».
 - Check that the headline contactor is turned «On». Check:
 - Manual-automatic-off switch is not in «Off» position.
 - Setting in the LCD panel (select time scheduler NO and the equipment should start up).
 - Check that input switch is turned «On». (Available in formats **(T)** or **(I)** only).

7.2.2.- If the equipment is on Bypass.

Check:

- Forced Bypass order is not activated in the terminal strip of any module.
- Forced Bypass order is not activated in the terminal strip of the control card BM491*.
- It is not turned «On» «M. shutdown» in the LCD panel.

7.3.- REPLACING ONE MODULE FROM ILUEST+ SET.

Before describing the steps to follow for replacing a module in a three phase system, a short mention of input switch and Manual Bypass (optional that can be fitted in by default or by the user according to diagram of figure 11), which are not available in format **(OEM)**, has to be done.

In case of damaging anyone of them and if it is a single phase or three phase equipment, proceed with the following step described in the procedure. Nevertheless in the event of not having manual

Bypass, the lamps will not be fed during faults, so the equipment has to be shutdown completely and proceed to replace the module directly, by respecting the other established steps.

Next, the actions to make for a three phase **ILUEST+** with switch **(4)** and manual Bypass **(7)** built in, are described. Therefore proceed according to the description of previous paragraph:

1. To remove any module **(0_n)**.
 - In equipments with format **(I)**, open front door **(Pf)** by means of the supplied key. When tasks are ended, close the door **(Pf)**.
 - Put the equipment on maintenance Bypass. Switch **(7)** in «**By-pass**» position.
 - Turn «Off» input switch **(4)** of the equipment. In those equipments without this switch, the input circuit breaker for **ILUEST+** protection has to be turned «Off», therefore the loads will not be fed (lights).
 - Disconnect the communication flat cable and 10 pins **(Fc)**, from connector **(Cb)** of faulty module **(0_n)** and located in the bottom side of each module.
 - Remove the screws **(t₁)** that fix the cover **(Tb)** and take the cover out. (equipments with format **(T)** or **(I)**).
 - Remove screw **(t₂)** that fix the cover **(Tm)** of module and separate slightly from the equipment from its bottom part and pull towards the roof (about 2 cm) till it goes out from its border.
 - Remove the connection cables from the terminal strip of the affected module **(0_n)**.
 - Remove screw **(t₃)** that fix the module:
 - If it is the only one module **(OEM)** (single phase equipment) unscrew both fixing screws **(t₃)** from top support and loosen slightly both screws from bottom support, and take out the module.
 - For any module **(OEM)** that belongs to a three phase system, unscrew both fixing screws **(t₃)** from bottom support and take down the module from top support by lifting it up to the roof slightly (about 4 cm), and take it out.

2. To replace a module **(0_n)**.

- Check that there is no voltage in the connection cables of module **(0_n)**.
- Put back the module **(0_n)** to its position in a reverse way when it was taken out. Proceed to fix it to the base that the previous one was hanged.
- Connect the connection cables to the terminal strip of the affected module **(0_n)**.
- Remove screw **(t₂)** that fix cover **(Tm)** of new module, separate slightly from the equipment from its bottom part and pull towards the roof (about 2 cm) till it goes out from its border.
- Check the communication address of the new module to insert it in a three phase system. In a single phase equipment is not needed to do this step.

By dipswitch SW1 of card BM510* (see figure 30), select the correct address as it is described as follows:

- The address of each module in a three phase system is established, from left to right and with the equipment seen from its front, as 1-2-3 and corresponds with phases R-S-T. For example:

In case of the most right module was fault (phase T), the

new module should have the address 3 (see figure 30) in order to have the correct communication with the rest of the equipment.

- Connect the communication flat cable and 10 pins **(Fc)**, from connector **(Cb)** of new module **(0.)** and located in the bottom side of each module.
- Turn «On» input switch **(4)** of the equipment. In those equipments without this switch, the input circuit breaker for **ILUEST+** protection has to be turned «On».
- Check that **ILUEST+** starts properly.
- Check the output voltage of the new module **(0*)**.
- Check the correct operating of the complete set.
- Turn «Off» input switch **(4)** of the equipment. In those equipments without this switch, the input circuit breaker for **ILUEST+** protection has to be turned «Off», therefore the loads will not be fed (lights).
- Put back cover **(Tm)** of new module and fix it through the screw **(t₂)**.
- In equipments with manual bypass, return it back to the position where the output is supplied from **ILUEST+**. Switch **(7)** to position «Stabilizer».

If the module **(0.)** to replace is the one in the center with LCD panel **(12)** and the LCD panel works properly, the LCD panel can be removed easily **(12)** from the faulty module and put back into the new one, because its modularity allows it.

- Remove screw **(t₂)** that fix cover **(Tm)** of new module, separate slightly from the equipment from its bottom part and pull towards the roof (about 2 cm) till it goes out from its border.
- Take out the control card and LCD panel, by pulling from it to the roof slightly and take out the connectors with its respective flat cables.
- Put the control card with LCD panel into the new module, and insert the flat cables connectors.

If the LCD panel has to be replaced **(12)** or the module with LCD panel is completely replaced, then the following parameters have to be selected:

Adress	SW1-1	SW1-2
1	OFF	OFF
2	ON	OFF
3	OFF	ON

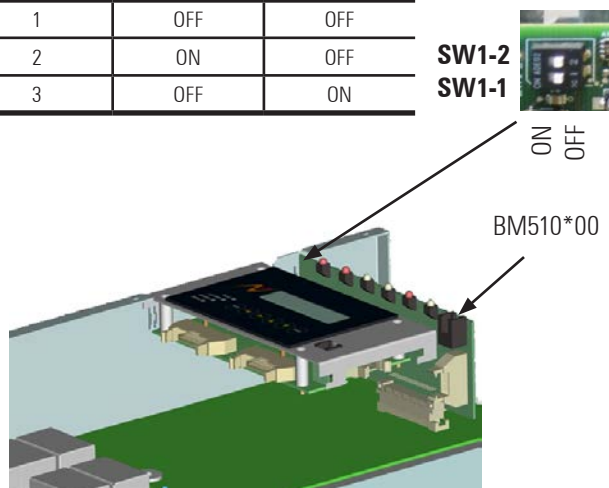

Fig. 30. Dip-switch SW1 to set address module.

- Nr of modules.
- Power of the equipment.
- Serial number.
- Clock setting.
- Type of lamps.
- Desired **ILUEST+** selections: start voltage, nominal, saving,....
- Astronomical clock setting: coordinates...
- Time scheduler.

7.4.- WARRANTY CONDITIONS.

The limited warranty by **our company** only applies to those products that you acquire for commercial or industrial use in the normal development of your business.

7.4.1.- Covered product.

Lighting Flow Dimmer-Stabilizer, **ILUEST+** model.

7.4.2.- Warranty terms.

This product is guaranteed against any parts and/or labour defect for 12 months period from its commissioning by **our company** staff or other specifically authorised, or 18 months from its factory delivery, whichever expires first. In case of failure of the product inside the warranty period, we must repair, at your facilities at no cost, the faulty part or parts. The transport expenses and packaging will be borne to the user.

We guarantees for period time higher than 10 years, the availability of parts and spare parts, as hardware as software, as well as a complete assistance regarding the reparations, components replacement and software updating.

7.4.3.- Out of scope of supply.

Our company is not forced by the warranty if it appreciates that the defect in the product doesn't exist or it was caused by a wrong use, negligence, installation and/or inadequate testing, tentative of repairing or not authorized modification, or any other cause beyond the foreseen use, or by accident, fire, lightnings or other dangers. Neither it will cover, in any case, compensations for damages or injuries.

7.5.- AVAILABLE MAINTENANCE AND SERVICE CONTRACTS.

When the warranty is expired, and adapting to the customer's needs, has several maintenance modalities:

Preventive.

It guarantees a higher safety to preserve the correct operating of the equipments with a yearly preventive visit, in which the specialised technicians of **our company** make several tests and sets in the systems:

- Check and write down the input and output voltages and currents per phase.
- Check the logged alarms (with the option telemanagement pack).
- Check the readings of the LCD panel.
- Digital LCD panel: input/output voltage and current and temperatures.
- Other measurements.
- Check the fan status.
- Check the load level.
- Check the selected language.
- Check the correct location of the equipment.
- General cleaning of the equipment.

This way, it is guaranteed the perfect operating and the possible coming faults are avoided.

These supervisions are usually done without shutdown the equipment. In those cases that a shutdown were needed, date and time would agree with the customer to do the task.

This maintenance modality covers, inside the working timetable, all the journey expenses and manpower.

Corrective.

When a fault occurs in the equipment operating, and previous notice to our Service and Technical Support (**S.T.S.**), in which a specialized technician will establish the failure scope and he will determine a first diagnostic, the corrective action starts.

The needed visits for its correct resolution are unlimited and they are included inside the maintenance modalities. It means that in case of failure, we will check the equipments as many time as it were needed.

Besides, inside these two modalities, is possible to fix the **action timetable and response times** in order to be adapted to the customer's needs:

- **LV8HLS.** Customer's attention from Monday to Friday from 9 h. to 18 h. The response time is inside the same day or, as maximum, in the next 24 hours of the fault notification.
- **LS14HLS.** Customer's attention from Monday to Saturday from 6 h. to 20 h. Response time is inside the same day or, as maximum, at first time of the next working day.
- **LD24HLS.** Customer's attention from Monday to Sunday 24 h., 365 days per year. Response time in less than two or three hours after the fault notification.

Additional arrangement: 1-m-cb.

- **Index 1.** It means the number or **Preventive** visits per year. It includes displacement and manpower expenses inside the established timetable for each maintenance modality, as well as all the needed **Corrective** visits. Excluding all the parts and batteries in case of reparation.
- **Index m.** It means to include all the **spare parts**.

7.6.- TECHNICAL SERVICE NETWORK.

The covering, as national as international, of Service and Technical Support (**S.T.S.**) points, are made up by:

At national level:

Madrid, Barcelona, Bilbao, Gijon, La Coruña, Las Palmas de G.Canaria, Malaga, Murcia, Palma de Mallorca, San Sebastian, Seville, Valencia and Zaragoza.

Subsidiaries:

Andorra, France, Portugal, Hungary, United Kingdom, China, Singapore, Uruguay and Mexico.

Rest of world:

Denmark, Sweden, Norway, Ireland, Holland, Belgium, Poland, Russia, Ukraine, Germany, Greece, Czech Republic, Switzerland, Chile, Peru, Argentina, Colombia, Brazil, Ecuador, Philippines, Indonesia, Malaysia, Thailand, Kazakhstan, Pakistan, Saudi Arabia, Jordan, Kuwait, Egypt, Algeria, Morocco and Tunisia.

8.- ANNEXES.

8.1.- GENERAL TECHNICAL SPECIFICATIONS.

TECHNOLOGY	
Type	Bi-directional converter of high frequency at IGBT's, electronic, static, transformerless and with continuous regulation of the output voltage.
INPUT	
Voltage	Single phase 230 V. Three phase 3x400 V (4 wires: 3 phases + N).
Regulation range	180 ÷ 220 V. + 25% / -7% U _{nominal} . + 25% / -17% U _{saving 1} (VSHP). + 25% / -10% U _{saving 2} (VM).
Frequency	40 ÷ 65 Hz.
Protection of module	Input and output fuses and electronic by temperature, overload, fault and input and output varistors.
Input switch (less formats OEM)	Two poles for single phase unit or four poles for three phase unit.
OUTPUT	
Power of modules / equipments	See table 8 to 12.
Voltage	Adjustable from 215 V to 230 V (220 V as standard)
Accuracy in regulation	> ±0,5%. Accuracy inside regulation range (input voltage 230 V +20% / -3%), better than ±0,5%.
Accuracy at limit of range	±2,5% ±2 V. Accuracy out from limits of regulation (input voltage 230 V ±7%) = ±2,5% ±2 V.
Soft start voltage	Preset depending on the type of lamp and adjustable.
Minimum saving level	180V (phase to neutral). Adjustable.
Ramp duration setting	From 1 V / minute to 6 V / minute.
Output voltage response / against input fluctuation	< 40 ms.
Regulation	Continuous and independent per phase.
Efficiency	> 95 %.
Phase unbalancing	100% permissible.
Saving voltage selection 1 or 2	With Telemangement Pack SICRES, with LCD panel or PC application.
Permissible overload	120 % for 1 minute.
Permissible power factor	From 0,5 lagging to 0,5 leading.
Total harmonic distortion	Relating to the fundamental reinjected by the equipment < 3 %.  Minimum load in the equipment to comply the harmonics limits of section 6.3 of norm EA 0033:2007 = 20% of nominal power.

BYPASS	
Type	No break.
Features	Automatic, static and contactor and independent per phase.
Activation criteria	Overtemperature, overload, fault, output fault, manual activation.
Rearmament	Automatic by alarm condition disappearing. Quantity of retries: 10; Time between retries: 8 sec..
MANUAL BYPASS (Optional)	
Type	Rotatory switch, two or four poles with 2 positions (1-2), make before break and auxiliary contact.
COMMUNICATIONS	
Equipment	RS-232 communication port
Equipment with control card BM491* 00, version digital I/O (optional)	RS-232 and RS-485 (optional) communication ports.
OTHER COMMUNICATIONS WITH CONTROL CARD BM491*00, VERSION DIGITAL I/O (OPTIONAL)	
Inputs	1 for Saving order. 1 for Bypass order. 5 digitals.
Outputs	5 dry contacts (they are provided with NO and NC contacts per each relay)
Communication port	RS-485 with connector SUB-D9. RS-232 with connector RJ of 4 pins.
Telemangement unit SICRES (optional)	Communication interface for Ethernet networks and TCP-IP protocol and SNMP, GSM / GRPS modem, RTC modem.  SICRES unit needs the external communication device as interconnection with the equipment.
ENVIRONMENTALS	
Cooling	Forced (see volume in table 4).
Operating temperature	20°C a +40°C (for higher temperatures derate the equipment 4 % per each °C over).
Storage temperature	-40°C to +55°C.
Relative humidity	Up to 95%, non-condensing.
Operating altitude	< 1.000 m.a.s.l.
Mean Time Between Failures (MTBF)	60.000 hours.
Mean Time To Repair (MTTR)	30 minutes.
Acoustical noise at 1 metre	< 48dBA (with typical load).
INDICATORS	
Optical (per phase)	Bypass Alarm Status Communications Local Bypass Local Saving

FORMATS AND PROTECTION	
(OEM) -original equipment manufactured- Degree IP20	Equipment to be fitted indoor both as a replacement of one module for a three phase equipment and to be integrated in particular installations. Pay attention to indoor format description (T) .
Indoor (T) with protection degree IP20	Equipment to be fitted indoor. Assembled inside a chassis of galvanised sheeted steel with painted covers with epoxy coat colour RAL-7032 and silk-screened, with base of four holes to fix it to the floor of the cabinet where it will built in.
Outdoors (I) with protection degree IP54	Independent equipment for outdoors. Assembled in a reinforced and insulated cabinet of polyester with grey colour RAL-7032.
Protection against electrical shocks	Class I.
STANDARDIZED OPTIONAL	
To be built in equipments with format (T) or (I)	Manual Bypass. Control card BM491*00. Interface for Ethernet networks SICRES (When control card BM491*00 is previously installed).
To be installed external to the equipment with format (T) or (I)	Manual Bypass (optional). GSM/GPRS modem and its communication antenna.
To be installed external to the equipment with format (OEM)	Manual Bypass. Control card BM491*00. Interface for Ethernet networks SICRES (When control card BM491*00 is previously installed).
STANDARDS	
Safety	UNE AENOR EA 0032-2007.
Electromagnetic compatibility (EMC)	IEC 62041.
Operating	UNE AENOR EA 0033-2007.
Marking	CE.
Environmental quality management	ISO 9001 and ISO 14001 TÜV.

Table 7. General technical specifications.

8.2. PARTICULAR TECHNICAL SPECIFICATIONS.

MODEL	POWER (kVA)	Version single phase Kit OEM	
		DIMENSIONS (mm) (Depth x Width x Height)	WEIGHT (kg)
Kit NE+ 3,5-2-LCD	3,5	200 x 172 x 345,4	6
Kit NE+ 6,5-2-LCD	5		6
Kit NE+ 10-2-LCD	10	200 x 172 x 505	14
Kit NE+ 15-2-LCD	15		14

Table 8. Dimensions and weights for single phase format **(OEM)**.

 Dimensions for single or three phase Kit (OEM) do not included the dimensions of support to hung up the modules.

MODEL	POWER (kVA)	Version three phase Kit OEM	
		DIMENSIONS (mm) (Depth x Width x Height)	WEIGHT (kg)
Kit NET+ 7,5-4-LCD	7,5	200 x 516 x 345,4	19
Kit NET+ 10-4-LCD	10		19
Kit NET+ 15-4-LCD	15		19
Kit NET+ 20-4-LCD	20		19
Kit NET+ 25-4-LCD	25	200 x 516 x 505	53
Kit NET+ 30-4-LCD	30		53
Kit NET+ 45-4-LCD	45		53

Table 9. Dimensions and weights for three phase format **(OEM)**.

MODEL	POWER (kVA)	INDOOR Version (T)	
		DIMENSIONS (mm) (Depth x Width x Height)	WEIGHT (kg)
NET+ 7,5-4 T	7,5	240 x 520 x 610	29
NET+ 10-4 T	10		30
NET+ 15-4 T	15		31
NET+ 20-4 T	20		33
NET+ 25-4 T	25	240 x 520 x 770	54
NET+ 30-4 T	30		55
NET+ 45-4 T	45		56

Table 10. Dimensions and weights for formats **(T)**.

MODEL	POWER (kVA)	INDOOR VERTICAL Version (TW)	
		DIMENSIONS (mm) (Depth x Width x Height)	WEIGHT (kg)
NET+ 7,5-4 TW	7,5	245 x 350 x 823	29
NET+ 10-4 TW	10		30
NET+ 15-4 TW	15		31
NET+ 20-4 TW	20		33
NET+ 25-4 TW	25	245 x 3500 x 1142	54
NET+ 30-4 TW	30		55
NET+ 45-4 TW	45		56

Table 11. Dimensions and weights for formats **(TW)**.

MODEL	POWER (kVA)	OUTDOOR Version (I)	
		DIMENSIONS (mm) (Depth x Width x Height)	WEIGHT (kg)
NET+ 7,5-4 I	7,5	320 x 750 x 1105	64
NET+ 10-4 I	10		65
NET+ 15-4 I	15		66
NET+ 20-4 I	20		68
NET+ 25-4 I	25		89
NET+ 30-4 I	30		90
NET+ 45-4 I	45		91

Table 12. Dimensions and weights for formats **(I)**.

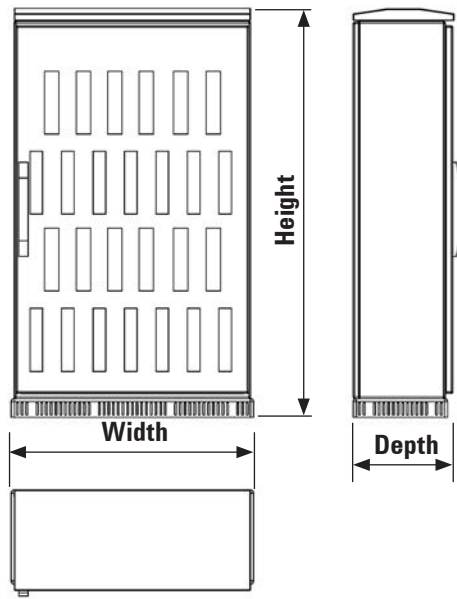
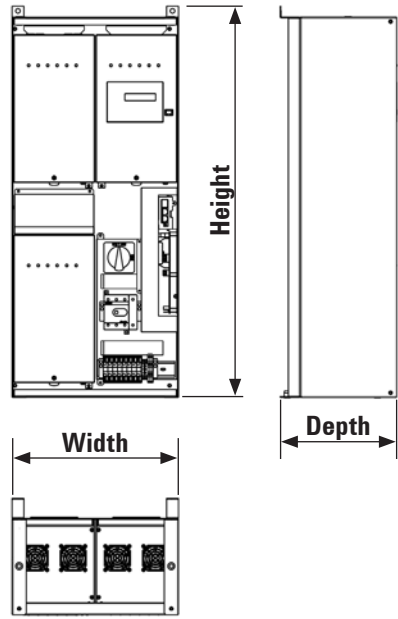
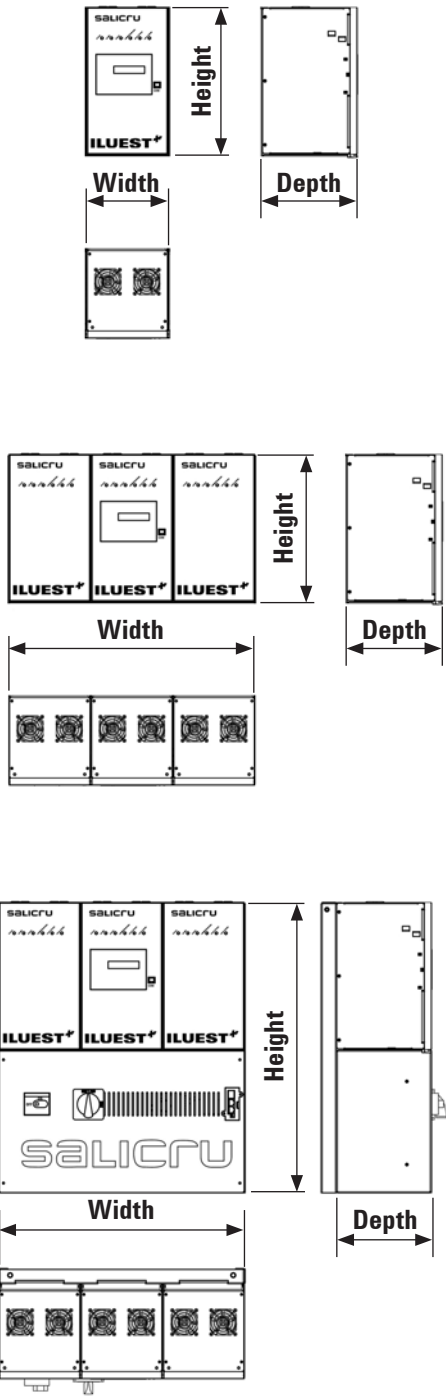

Fig. 31. Profile of the different formats.

Arranque suave.

Type of start up or turning on the lights. It is done in order to avoid the mechanical stress that the lamps suffer and the overload that it means when they are started at nominal.

Bypass.

System that connects the output with the input directly when there is a failure in the loads or equipment. It avoids to shutdown the lighting.

Control center.

Electrical panel destined to feed, distribute, protect, etc., the lighting installations.

Electromagnetic compatibility.

Its target is to establish evaluation procedures of conformity and electromagnetic protection requirements relating to electromagnetic compatibility of the equipments, systems and installations for its following marketing and commissioning.

Dry contacts.

Electrical contacts are parts of management that connect or disconnect our receivers (coils, lights, motors, etc.). Those contacts are housed inside the contact chamber and they work by different systems, i.e. buttons, switches, relays, etc.

Harmonic currents.

Added currents to the fundamental frequency with a determined sinewave shape. They are called like this because when this harmonics currents appear, they distort the original wave shape.

Equipment to incorporate.

Equipment based on a chassis that has all the parts in, being not able to have any specific protection against electrical shocks.



In this case the electrical shock protection has to be provided by an additional enclosure that it will be fitted in the final installation.

Equipment of continuous variation.

Equipment where the output voltage varies in a continuous way or steps lower than 0,3 % of the nominal voltage.



They are habitually characterized, because the power stage is based on a variable and motorized autotransformer. The voltage provided to the loads is given by the autotransformer directly through the carbon brushes system, or in combination with a transformer, called «booster» that adds or subtracts; or the voltage variation is given by pure power static parts.

Equipments with step variation.

Equipment where the output voltage varies in steps higher or equal to 0,3 % of the nominal voltage.



They are habitually characterized, because the power stage is based on a tap autotransformer. The voltage provided to the loads is given by the autotransformer directly, or in combination

with a transformer, called «booster» that adds or subtracts; The switching between the different taps can be done with static, electromechanical or dynamic parts.

Dynamic equipments.

Equipment to make functions of voltage stabilizing and light flow dimming, where its main circuit uses parts with motorized movement (motorized variable autotransformers, carbon brushes, etc.).

Static equipments.

Equipment to make functions of voltage stabilizing and light flow dimming, where its main circuit uses static parts (thyristors, triacs, etc.).

Independent equipment.

Equipment housed in an enclosure completely closed, less the bottom surface, in order to assure the protection degree according to its marking.

Outdoor.

Denomination used to designate the capacity of the enclosure, due to its protection degree to be placed outdoor.

Relay interface.

Communication port of the equipment with the external world, made up by some dry contacts.

Static solid switch.

Electrically speaking, it is an electronic switch without physical movement based on a silicon square with a particular mix.

IP20 / IP54.

Suitable protection degree to withstand the inclemency of the weather.

Marcado CE.

Certification that has to meet all the electrical equipments in Europe. Any manufacturer has its own capacity for its autocertification.

Telemanagement pack.

Optional pack to establish local and/or remote communication with **ILUEST**. It contents a card, built in the equipment, and application software.

Time scheduler.

Clock with capacity to temporize the activation of one or several relays.

Astronomical clock.

Clock with mathematical algorithm, which is able, by programming the latitude and longitude of a determined geographical point previously, to keep the sunset and sunrise tables of all the days of the year. Usually it is used to turn on/off the lighting in an accurate way.

Indoor.

Denomination used to designate the location of the equipment inside of an existent feeder pillar or control centre.

SALICRU

Avda. de la Serra, 100
08460 Palautordera
BARCELONA
Tel. +34 93 848 24 00
902 48 24 00
Fax. +34 94 848 11 51
comercial@salicru.com
Tel. (S.T.S.) 902 48 24 01
Fax. (S.T.S.) +34 848 22 05
sst@salicru.com
SALICRU.COM

BRANCHES AND SERVICES and TECHNICAL SUPPORT (S.T.S.....)

MADRID	PALMA DE MALLORCA
BARCELONA	PAMPLONA
BADAJOS	SAN SEBASTIAN
BILBAO	SANTA CRUZ DE TENERIFE
GIJÓN	SEVILLA
LA CORUÑA	VALENCIA
LAS PALMAS DE G. CANARIA	VALLADOLID
MÁLAGA	ZARAGOZA
MURCIA	

SUBSIDIARIES

FRANCIA	RUSIA
PORTUGAL	CHINA
HUNGRIA	SINGAPUR
REINO UNIDO	MÉXICO
POLONIA	URUGUAY

REST of WORLD

ALEMANIA	ECUADOR
BÉLGICA	PERÚ
DINAMARCA	ARABIA SAUDÍ
GRECIA	ARGELIA
HOLANDA	EGIPTO
IRLANDA	JORDANIA
NORUEGA	KUWAIT
REPÚBLICA CHECA	MARRUECOS
SUECIA	TÚNEZ
SUIZA	KAZAJSTÁN
UCRANIA	PAKISTÁN
ARGENTINA	FILIPINAS
BRASIL	INDONESIA
CHILE	MALASIA
COLOMBIA	TAILANDIA

Product Range

Uninterruptible Power Supply UPS
 Voltage Stabilizers and Power Line Conditioners
 Switch Mode Power Supplies
 Industrial Power Supplies
 Lighting Flow Dimmer-Stabilizers
 Static Inverters
 Continuous Regulation Autotransformers

