

USER MANUAL



UNINTERRUPTIBLE POWER SUPPLIES (UPS)

SLC TWIN RT2 A

1, 2 and 3 kVA

SALICRU

Table of contents.

1. INTRODUCTION.

1.1. THANK YOU LETTER.

2. SAFETY INFORMATION.

2.1. USING THIS MANUAL.

2.1.1. Conventions and symbols used.

2.2. WIRING CONSIDERATIONS.

3. QUALITY ASSURANCE AND STANDARDS.

3.1. STATEMENT BY THE MANAGEMENT.

3.2. STANDARDS.

3.3. ENVIRONMENT.

4. PRESENTATION.

4.1. VIEWS.

4.1.1. Views of the device.

4.2. DEFINITION OF THE PRODUCT.

4.2.1. Nomenclature.

4.3. OPERATING PRINCIPLE.

4.4. UPS OPERATING MODES.

4.4.1. Notable features.

4.5. OPTIONAL EXTRAS.

4.5.1. Isolation transformer.

4.5.2. Exterior manual maintenance bypass.

4.5.3. Communications card.

4.5.3.1. Integration into computer networks using an SNMP adapter.

4.5.3.2. RS-485 modbus.

4.5.3.3. Relay interface.

4.5.4. Extendable guide kits for mounting in a rack cabinet.

5. INSTALLATION.

5.1. RECEPTION OF THE DEVICE.

5.1.1. Reception, unpacking and contents.

5.1.2. Storage.

5.1.3. Unpacking.

5.1.4. Transportation to the site.

5.1.5. Siting, immobilising and considerations.

5.1.5.1. Rotation of the control panel with LCD.

5.1.5.2. Vertical tower-type mounting.

5.1.5.3. Vertical tower-type mounting with backup extension (battery module).

5.1.5.4. Mounting as a rack in a 19" cabinet.

5.1.5.5. Rack mounting in a 19" cabinet with backup extension (battery module).

5.1.5.6. Preliminary considerations before connection.

5.1.5.7. Preliminary considerations before connection, regarding the batteries and their protections.

5.1.5.8. Connection elements.

5.2. CONNECTIONS.

5.2.1. Connection of the input.

5.2.2. Connection of the NEMA output sockets.

5.2.2.1. Connection of loads in models up to 3 kVA.

5.2.3. Connection to external batteries (backup extension).

5.2.4. Terminals for EPO (emergency power off).

5.2.5. Communications port.

5.2.5.1. RS-232 and USB port.

5.2.6. Smart slot for the integration of an electronic communication unit.

5.2.7. Protection against voltage spikes for the modem / ADSL / fax, etc., line.

5.2.8. Software.

5.2.9. Considerations before startup with connected loads.

6. OPERATION.

6.1. STARTUP.

6.1.1. Checks before startup.

6.2. UPS STARTUP AND SHUTDOWN.

6.2.1. UPS startup with mains voltage.

6.2.2. UPS startup without mains voltage.

6.2.3. UPS shutdown with mains voltage.

6.2.4. UPS shutdown without mains voltage.

7. CONTROL PANEL WITH LCD.

7.1. GENERAL INFORMATION FOR THE SERIES.

7.1.1. Information represented by the display.

7.1.2. Common messages shown on the LCD display.

7.1.3. Common abbreviations shown on the display.

7.2. CONTROL PANEL.

7.2.1. Composition of the control panel with LCD display.

7.2.2. Audible alarms.

7.2.3. Location of the setting parameters on the display.

7.2.4. Settings.

7.2.4.1. Ah configuration of parameter '12.'

7.2.4.2. Operating mode / Description of state.

7.2.4.3. Warning or alert codes.

7.2.4.4. Error or fault codes.

7.2.4.5. Warning or alert indicators.

8. MAINTENANCE, WARRANTY AND SERVICE.

8.1. BATTERY MAINTENANCE.

8.1.1. Notes for the installation and replacement of the battery.

8.2. UPS TROUBLESHOOTING GUIDE.

8.2.1. Troubleshooting guide.

8.3. WARRANTY CONDITIONS.

8.3.1. Terms of the warranty.

8.3.2. Exclusions.

8.4. TECHNICAL SERVICES NETWORK.

9. ANNEXES.

9.1. GENERAL TECHNICAL SPECIFICATIONS.

9.2. GLOSSARY.

1. INTRODUCTION.

1.1. THANK YOU LETTER.

We thank you in advance for the trust placed in us in the purchasing of this product. Read this instruction manual carefully in order to familiarise yourself with its content, since the more you know and understand the device the greater your satisfaction, level of safety and optimisation of its functionalities will be.

We remain at your disposal for any additional information or queries that you may wish to make.

Yours sincerely.

SALICRU

- The device described here **is capable of causing significant physical injury if improperly handled**. For this reason, its installation, maintenance and/or repair must be carried out exclusively by our staff or **qualified personnel**.
- Although no effort has been spared to ensure that the information in this user manual is complete and accurate, we accept no liability for any errors or omissions that may exist. The images included in this document are for illustrative purposes and may not exactly represent the parts of the device shown; therefore they are not contractual. However, any divergence that may arise will be remedied or solved with the correct labelling on the unit.
- Following our policy of constant evolution, **we reserve the right to modify the characteristics, operations or actions described in this document without prior notice**.
- **Any reproduction, copying, assignment to third parties, amendment or total or partial translation** of this manual or document, in any form or by any means, **without the prior written permission of Salicru is prohibited**, with the company fully and exclusively reserving its property rights over it.

2. SAFETY INFORMATION.

2.1. USING THIS MANUAL.

The documentation of any standard equipment is available to the customer on our website for download (www.salicru.com).

- For devices 'powered by socket,' this is the website for obtaining the user manual and '**Safety Instructions**' EK266*08.
- For devices with 'permanent connection' via terminals, a CD-ROM or pen drive containing all necessary information for connection and startup, including '**Safety Instructions**' EK266*08, may be supplied with it.

Before carrying out any action on the device relating to its installation or startup, change of location, configuration or handling of any kind, carefully read the safety instructions.

The purpose of the user manual is to provide information regarding safety and explanations of the procedures for installation and operation of the equipment. Read it carefully and follow the steps indicated in the order established.



Compliance with the 'Safety Instructions' is obligatory, with the user being legally responsible for observing and applying them.

The device is delivered properly labelled for correct identification of each of its parts, which, together with the instructions described in this user manual, allows installation and startup operations to be performed in a simple and organised manner without any doubts whatsoever.

Finally, once the equipment is installed and operating, it is recommended to save the documentation downloaded from the website, CD-ROM or pen drive in a safe and easy-to-access place, for any future queries or doubts that may arise.

The following terms are used interchangeably in the document to refer to:

- '**SLC TWIN RT2 A,' 'TWIN RT2,' 'TWIN,' 'RT2,' 'device,' 'unit' and 'UPS'** - Uninterruptible power supply. Depending on the context of the phrase, it can refer either to the actual UPS itself or to the UPS and the batteries, regardless of whether it is all assembled in the same metal enclosure or not.
- '**Batteries' or 'accumulators'** - Bank or set of elements that stores the flow of electrons by electrochemical means.
- '**T.S.S.**' - Technical Service and Support.
- '**Customer,' 'installer,' 'operator' or 'user'** - These are used interchangeably and by extension to refer to the installer and/or operator who will carry out the corresponding actions, and the same person may be responsible for carrying out the respective actions when acting on behalf, or in representation, of the above.

2.1.1. Conventions and symbols used.

Some symbols may be used and appear on the device, batteries and/or in the context of the user manual.

For more information, see Section 1.1.1 of the '**Safety Instructions**' document EK266*08.

2.2. WIRING CONSIDERATIONS.

Only use harmonised VDE or UL cables for powering the loads connected to the UPS.

3. QUALITY ASSURANCE AND STANDARDS.

3.1. STATEMENT BY THE MANAGEMENT.

Our goal is customer satisfaction, therefore this Management has decided to establish a Quality and Environment Policy, through the implementation of a Quality and Environmental Management System that will enable us to comply with the requirements demanded in the **ISO 9001** and **ISO 14001** and also by our Customers and Stakeholders.

Likewise, the management of the company is committed to the development and improvement of the Quality and Environmental Management System, through:

- Communication to the entire company of the importance of satisfying both the customer's requirements as well as legal and regulatory requirements.
- The dissemination of the Quality and Environment Policy and the setting of the Quality and Environment objectives.
- Conducting reviews by the Management.
- Providing the necessary resources.

3.2. STANDARDS.

The SLC TWIN RT2 A is designed, manufactured and sold in accordance with Quality Management Standard **EN ISO 9001**.

The **EC** marking indicates conformity with EC Directives:

- **2014/35/EU** - Low voltage safety.
- **2014/30/EU** - Electromagnetic compatibility **[EMC]**
- **2011/65/EU** - Restriction of the use of hazardous substances in electrical and electronic equipment **[RoHS]**

In accordance with the specifications of harmonised standards:

- **EN-IEC 62040-1**. Uninterruptible power supplies **[UPS]**. Part 1.1: Safety requirements.
- **EN-IEC 62040-2**. Uninterruptible power supplies **[UPS]**. Part 2: Electromagnetic compatibility **[EMC]** requirements.



WARNING!

SLC TWIN RT2 A 1, 2 and 3 kVA. This is a category C2 UPS. In a residential environment, this product may cause radio interference, in which case the user must take additional measures.

It is not appropriate to use this device with basic life support applications, where a failure of the former can render vital equipment out of service or significantly affect its safety or effectiveness. It is also not recommended in medical applications, commercial transport, nuclear installations, or other applications or loads, where a failure of the product can lead to personal or material damage.



The EC declaration of conformity of the product is available to the customer upon express request to our offices.

And **UL, CSA and FCC** markings in accordance with the specifications of standards:

- **UL 1778**
- **CSA C22.2 NO.107.3.-14**
- **FCC part 15 Subpart B**



ELECTROMAGNETIC COMPATIBILITY WARNING (FCC):

- **SLC-1000-TWIN RT2 A**. This UPS has been tested and meets the limits for a Class B digital device, pursuant to the FCC Part 15 standard. These limits are defined to provide reasonable protection against harmful interference when the device operates in a residential environment.

This device generates, uses and can radiate radio frequency energy and, if not installed and used in accordance with the instruction manual, may cause harmful interference to radio communications. There is, however, no guarantee that interference will not occur in a particular installation. If this device causes harmful interference to radio or television reception, which can be determined by simply turning the device off and on, the user is encouraged to try to correct the interference by one or more of the following measures:

- Reorientate or relocate the receiving antenna.
- Increase the distance between the device and receiver.
- Connect the device to a power socket on a different circuit to which the receiver is connected.
- Request help from the distributor of an experienced radio/TV technician.

- **SLC-2000-TWIN RT2 A** and **SLC-3000 TWIN RT2 A**. This UPS has been tested and meets the limits for a Class A digital device, pursuant to the FCC Part 15 standard. These limits are defined to provide reasonable protection against harmful interference when the device operates in a commercial environment.



This device generates, uses and can radiate radio frequency energy and, if not installed and used in accordance with the instruction manual, may cause harmful interference to radio communications. Operation of this UPS in a residential environment may cause harmful interference, in which case the user must correct the interference at their own expense.



The manufacturer is not liable in the event of modification or intervention on the device by the user.



WARNING CONCERNING BATTERIES (UL):

- Maintenance of the batteries must be carried out or supervised by personnel who have knowledge of the batteries and the necessary precautions.
- Batteries should not be replaced by the operator or user.
- When changing batteries, replace them with the same type and number.
-  **Caution:** Do not dispose of batteries in fire, as they may explode.
-  **Caution:** Do not open or break apart batteries. The electrolyte discharged can be harmful to the skin and eyes. It can be toxic.
-  **Caution:** Batteries can pose a risk of electrocution and cause a high short-circuit current. The following precautions should be observed when working with them:
 - a. Remove any watches, rings or other metal objects.
 - b. Use tools with insulated handles.
 - c. Wear gloves and rubber boots.
 - d. Do not leave tools or metal objects on top of the batteries.
 - e. Disconnect the power source before connecting or disconnecting the battery terminals.
 - f. Determine whether the battery is accidentally earthed. If so, disconnect the power source. Contact with any part of a battery that is earthed can cause electrocution. The likelihood of electrocution can be reduced if such connections are eliminated during installation and maintenance (applicable to devices and battery cabinets that do not have a power circuit connected to earth).

3.3. ENVIRONMENT.

This product has been designed to respect the environment and manufactured in accordance with **ISO 14001**.

Recycling of the device at the end of its useful life:

Our company undertakes to use the services of authorised and regulatory companies to treat the set of products recovered at the end of their useful life (contact your distributor).

Packaging:

For the recycling of the packaging there must be compliance with the legal requirements in force, in accordance with the specific regulations of the country where the device is installed.

Batteries:

Batteries pose a serious danger to health and the environment. The disposal of them shall be carried out in accordance with the laws in force.

4. PRESENTATION.

4.1. VIEWS.

4.1.1. Views of the device.

In to , illustrations of the device are shown according to enclosure size in relation to the power rating of the model. However, because the product is constantly evolving, discrepancies or slight contradictions may arise. If in any doubt, the labelling on the device itself will always prevail.

i The nameplate of the device shows all of the values relating to its main properties and characteristics. Act accordingly for its installation.

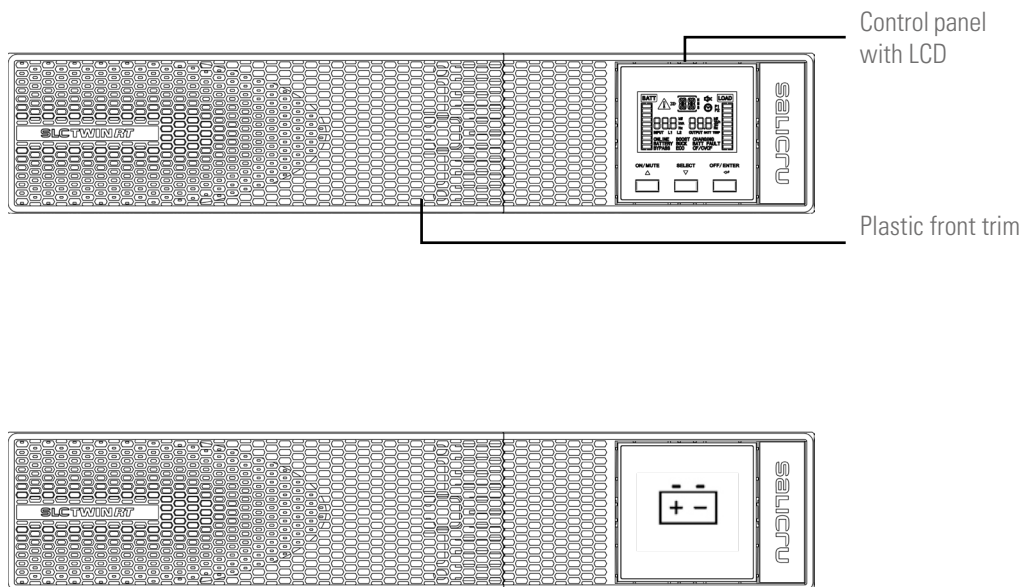

Fig. 1. Front view of the devices and battery modules for extended backups.

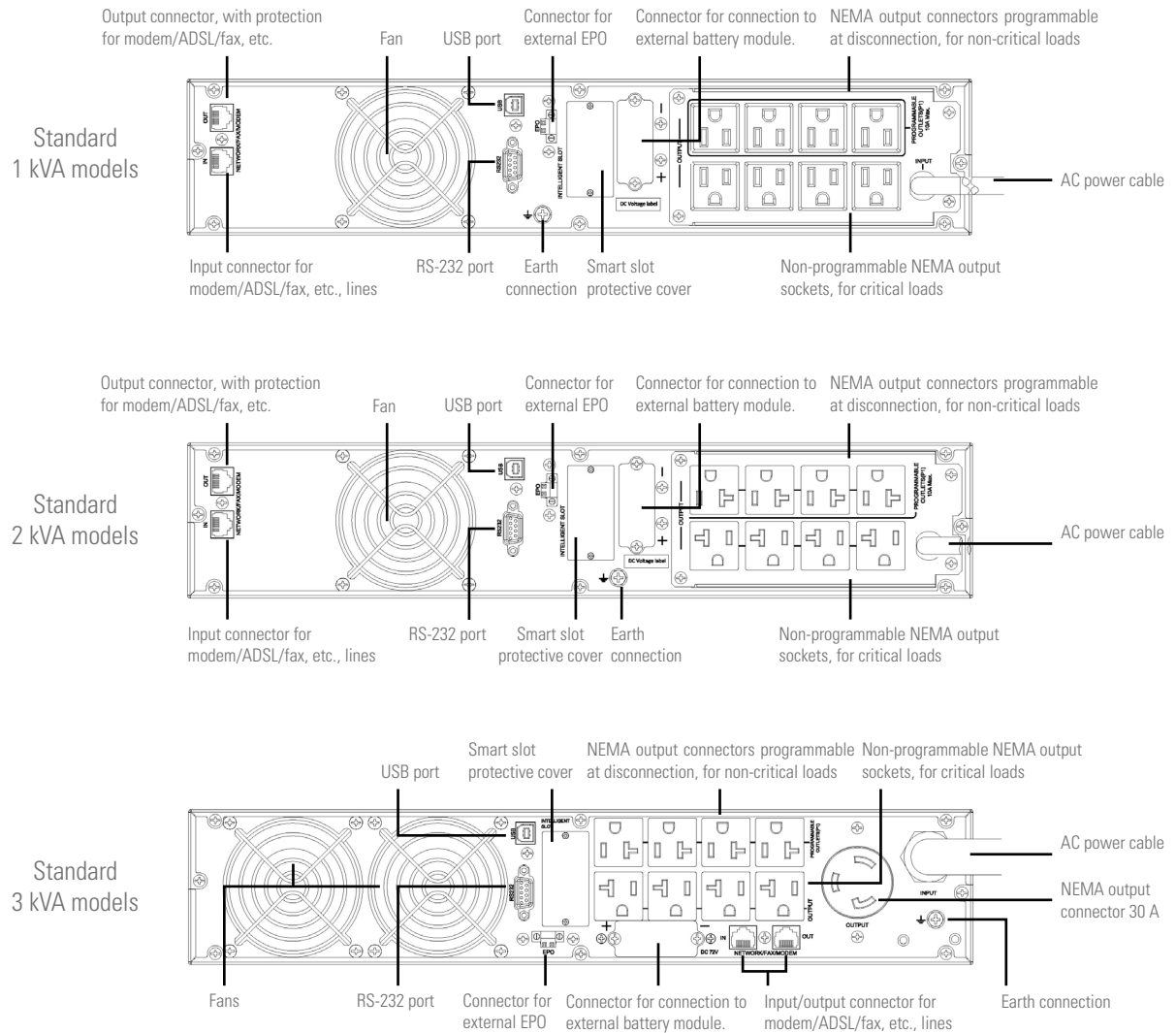

Fig. 2. Rear view of 1 to 3 kVA models.

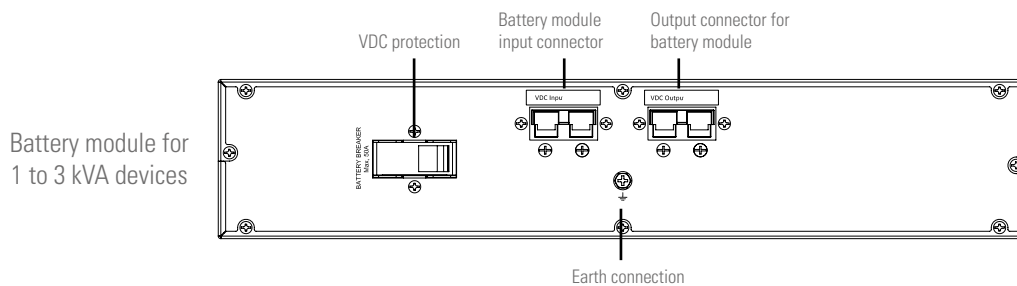
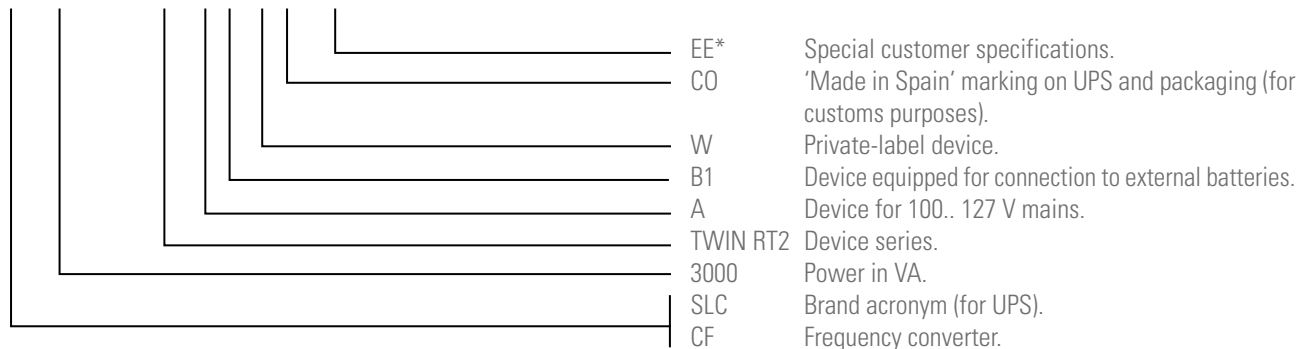

Fig. 3. Rear view of battery modules for extended backups.

4.2. DEFINITION OF THE PRODUCT.

4.2.1. Nomenclature.

SLC-3000-TWIN RT2 A B1 WCO EE29503



MOD BAT TWIN RT2 2x6AB003 40A WCO EE29503

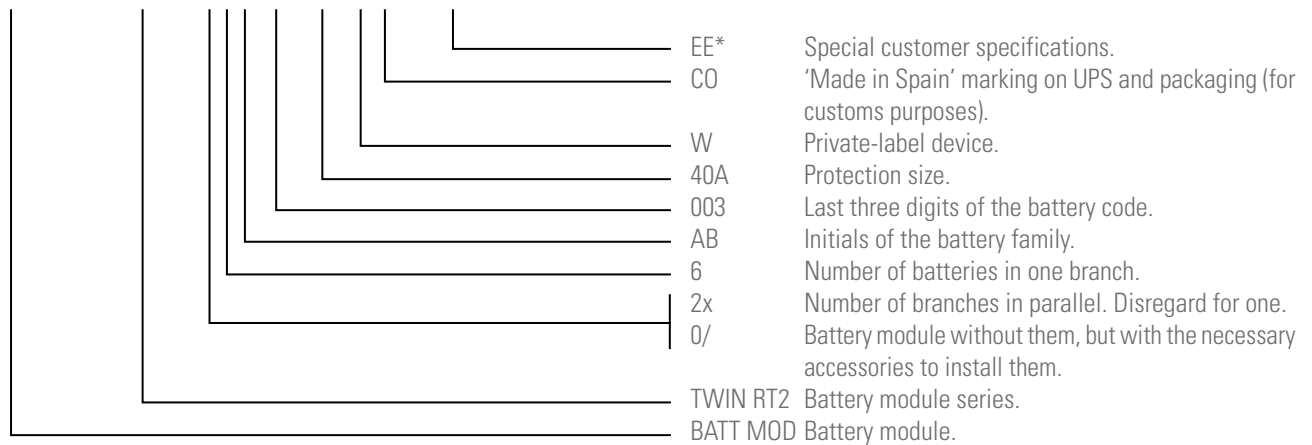

4.3. OPERATING PRINCIPLE.

This manual describes the installation and operation of SLC TWIN RT2 A series UPSs. SLC TWIN RT2 A series UPSs ensure optimum protection of any critical load, maintaining the supply voltage of the loads between the specified parameters without interruption during failure, deterioration or fluctuation of mains power, and come in a wide range of models (from 1 kVA to 3 kVA), enabling the end user to select the model that best suits his needs.

Thanks to their PWM (pulse width modulation) and double-conversion technology, SLC TWIN RT2 A series UPSs are compact, cool, silent and high performance.

The double converter principle eliminates all mains power disturbances. A rectifier converts the AC current of the mains into DC current, thereby maintaining optimum battery charge level and powering the inverter, which, in turn, generates a suitable AC sine-wave voltage for continuously powering the loads. In the event of failure of the UPS's mains power, the batteries supply clean power to the inverter.

The design and construction of the SLC TWIN RT2 A series UPS has been carried out in accordance with international standards. Thus, this series has been designed to maximise the availability of critical loads and to ensure that your business is protected

from variations in power distribution line voltage, frequency, electrical noise, cuts and micro-cuts. This is the primary goal of SLC TWIN RT2 A series UPSs.

This manual applies to the standardised models shown in .

4.4. UPS OPERATING MODES.

- Normal mode.
Device running supplying output voltage from the inverter. Mains power present with correct input voltage and frequency.
- Battery mode.
Device running with mains voltage or frequency out of range or without AC input power, either due to mains failure or absence of cable connection, supplying output voltage from the batteries.
- Bypass mode.
Device running or not, supplying output voltage directly from the AC mains.
 - ❑ With the inverter running, this operating mode may be due to an overload, blockage or inverter fault.

The actions for each incident will be as follows: Reduce the load connected to the output, unblock the device by resetting it - stop it and start it up again - and, if the blockage or fault remains, contact our **T.S.S.**

- ❑ With the inverter shut down, the output supplies mains power directly through the static bypass of the device provided that it has AC input power.
- Frequency converter (CF) mode.
Operating mode of the UPS as a frequency converter. In this mode, the static bypass is disabled by the condition of disparate input and output frequencies.



Even if the LCD on the backlit control panel shows messages, it does not mean that the inverter is operational. It is switched on by pressing the 'ON' button on the control panel, see Chapter .

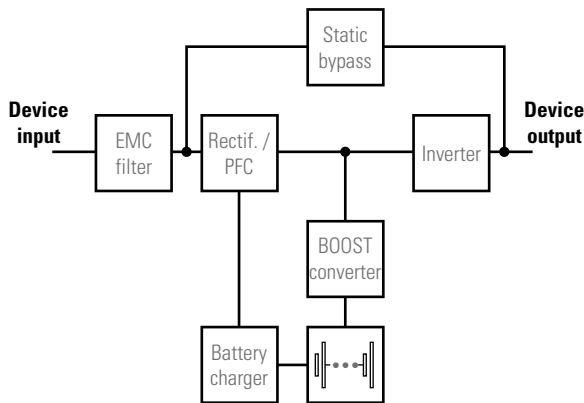

Fig. 4. Block diagram.

4.4.1. Notable features.

- True on-line with double-conversion technology and output frequency separate from the mains.
- Output power factor 0,9. Pure sine-wave waveform, suitable for all types of load.
- Input power factor > 0,99 and high overall efficiency between 0,89 and 0,91 depending on model. Greater energy savings and lower user installation costs (wiring), as well as low distortion of the input current, which reduces pollution in the power supply network.
- Great adaptability to the worst conditions of the mains. Wide input voltage, frequency and waveform ranges, thus avoiding excessive dependence on limited battery power.
- Possibility of fast and easy backup extension by adding modules in rack format. Each battery module has two connectors for easy connection to the device and other identical modules.
- Availability of battery chargers of up to 6 A to reduce battery recharge times.
- Selectable high-efficiency mode (ECO MODE) $\geq 0,96$ with battery charged. Energy savings, economically beneficial to the user.
- Possibility of starting the device without mains power supply or discharged battery. Pay attention to this last aspect because the more the batteries are discharged, the more the backup will be reduced.
- Intelligent battery management technology is very useful for extending the life of accumulators and optimising recharge times.

- Standard communication options via the RS-232 serial port or USB port.
- Remote emergency power off control (EPO).
- Control panel with LCD available on all models.
- Availability of optional connectability cards to improve communication capabilities.
- Device that can be installed as a tower or rack using the accessories supplied. The control panel can be rotated to adapt to either format.

Model	Type	Input/output type
SLC-1000-TWIN RT2 A	Standard	Single-phase / Single-phase
SLC-2000-TWIN RT2 A		
SLC-3000-TWIN RT2 A		
SLC-1000-TWIN RT2 B1 A	Extended backup	
SLC-2000-TWIN RT2 B1 A		
SLC-3000-TWIN RT2 B1 A		

Tab. 1. Standardised models.

4.5. OPTIONAL EXTRAS.

Depending on the configuration chosen, the device can include any of the following options:

4.5.1. Isolation transformer.

The isolation transformer provides galvanic isolation in order to completely isolate the output from the input and/or change neutral mode.

The placement of an electrostatic screen between the primary and secondary windings of the transformer provides a high level of electrical noise attenuation.

The isolation transformer can be physically placed at the input or output of the UPS depending on the technical conditions of the whole system (device supply voltage and/or load voltage, characteristics or their type, etc.).

In any event, it will always be supplied as a peripheral component external to the device itself in a separate enclosure.

4.5.2. Exterior manual maintenance bypass.

The purpose of this option is to electrically isolate the device from the mains and the critical loads without cutting the power to the latter. In this way, maintenance or repair operations on the device can be carried out without interruptions to the power supply of the protected system, while preventing unnecessary hazards for technical personnel.

4.5.3. Communications card.

The UPS features a smart slot at the rear for inserting one of the following communications cards.

4.5.3.1. Integration into computer networks using an SNMP adapter.

Large computer systems based on LANs and WANs that integrate servers in different operating systems must provide the system manager with ease of control and administration. This facility is obtained through an SNMP adapter, which is universally supported by the main software and hardware manufacturers.

Connection of the UPS to the SNMP is internal while that of the SNMP to the computer network is made through an RJ45 10 base connector.

4.5.3.2. RS-485 modbus.

Large computer systems based on LANs and WANs often require that communication with any element that is integrated into the computer network be made through a standard industrial protocol.

One of the most used standard industrial protocols on the market is the MODBUS protocol.

4.5.3.3. Relay interface.



- The UPS has, as an option, a relay interface card that provides digital signals in the form of potential-free contacts, with a maximum applicable voltage and current of 240 V AC or 30 V DC and 1A.
- This communications port enables dialogue between the device and other machines or devices through the relays supplied in the terminal block arranged on the same card, with a single common terminal for all of them.
From the factory, all contacts are normally open and can be changed one by one, as indicated in the information supplied with the optional extra.
- The most common use of these types of ports is to provide the necessary information to the file-closing software.
- For more information, contact our **T.S.S.** or our nearest distributor.

4.5.4. Extendable guide kits for mounting in a rack cabinet.

An extendable and unique guide kit is available for all device models, valid for any kind of rack-type cabinet.

These guides allow the installation of any TWIN RT2 A device unit and possible battery modules in the case of extended backups, as if it were a rack in its respective cabinet.

5. INSTALLATION.

-  Read and respect the Safety Information, described in Chapter 2 of this document. Failure to obey some of the instructions described in this manual can result in a serious or very serious accident to persons in direct contact or in the vicinity, as well as faults in the device and/or loads connected to it.
- Unless otherwise indicated, all actions, instructions, guidelines and notes are applicable to all of the models.
-  During discharge, the equipment operates in IT (isolated earth) neutral mode. This means that the neutral is not directly connected to earth, providing an additional layer of safety and stability in critical situations. To ensure optimal and safe operation, follow the guidelines in the user manual and contact your distributor if you have any questions.

5.1. RECEPTION OF THE DEVICE.

- Pay attention to section 1.2.1. of the safety instructions -EK266*08- in all matters relating to the handling, movement and siting of the unit.
- Use the most suitable means to move the UPS while it is packed, either with a pallet jack or forklift.
- Any handling of the device must be carried out in accordance with the weights shown in the technical specifications according to the model, indicated in Chapter '9. Annexes'.

5.1.1. Reception, unpacking and contents.

- Reception. Check that:
 - The data on the label affixed to the packaging corresponds to that specified on the order. Once the UPS is unpacked, check the previous data with those of the device nameplate.
If there are discrepancies, report the issue as soon as possible, citing the device's manufacturing number and delivery note references.
 - It has not suffered any mishaps during transportation (packaging and impact indicator in perfect condition). Otherwise, follow the protocol indicated on the label attached to the impact indicator, located on the packaging.
- Unpacking.
 - To check the contents, it will be necessary to remove the packaging.
 -  Complete the unpacking according to the procedure of section 5.1.3.
- Contents.
 - 1 to 3 kVA device:
 - 1 UPS.
 - Information for warranty registration.
 - 1 USB cable.
 - 2 metal pieces for use as handles and screws for installing the unit in a rack cabinet.
 - 4 plastic pieces for use as a base to facilitate the arrangement of the UPS as a tower (vertical position).
 - Optional battery module for 1 to 3 kVA battery module:
 - 1 battery module.
 - Information for warranty registration.
 - 2 metal pieces for use as handles and screws for

installing the unit in a rack cabinet.

- 2 plastic pieces to extend the base of the UPS and enable the arrangement of the attached battery module in its mounting as a tower.
- 1 cable for interconnecting the battery module and UPS or other module.
- Once the reception is completed, it is advisable to re-pack the UPS until it is put into service in order to protect it against mechanical shock, dust, dirt, etc.
- The packaging of the device consists of a wooden pallet, cardboard or wooden box, depending on the item, expanded polystyrene corners, polyethylene cover and strapping, all of which are recyclable materials. When the packaging requires disposal, it must be carried out in accordance with current laws.
We recommend keeping the packaging for at least 1 year.

5.1.2. Storage.

- The device storage shall be done in a dry, ventilated place and protected from rain, dust, water splashes or chemical agents. It is advisable to keep each device and battery unit in its original packaging, which is specifically designed to ensure maximum protection during transportation and storage.
-  For devices that contain Pb-Ca batteries, the charging times indicated in Tab. 2 of document EK266*08 regarding the temperature to which they are exposed, must be respected, otherwise the warranty may be invalidated.
- After this period, connect the device to the mains together with the battery unit if applicable, start it according to the instructions described in this manual and charge for 12 hours.
- Then shut down the device, disconnect it and store the UPS and batteries in their original packaging, noting the new date for recharging the batteries on a document as a record or even on the packaging itself.
- Do not store the devices where the ambient temperature exceeds 50°C or drops below -15°C, as this may cause degradation of the electrical characteristics of the batteries.

5.1.3. Unpacking.

- The packaging of the device consists of a cardboard box, expanded polystyrene (EPS) or polyethylene foam (EPE) corners, polyethylene cover and strapping, all of which are recyclable materials; consequently, if it requires disposal, it must be carried out in accordance with current laws. We recommend keeping the packaging in case it needs to be used in the future.
- Proceed as follows:
 - Cut the straps around the cardboard box.
 - Remove the accessories (cables, brackets, etc.)
 - Remove the device or battery module from the box with the help, if necessary, of a second person depending on the weight of the model or using appropriate mechanical means.
 - Remove the protective corners from the device and the plastic bag.
 -  Do not leave the plastic bag within the reach of children to avoid danger of suffocation.

- Inspect the device before proceeding and, in the event of finding damage, contact the supplier or, failing that, our firm.

5.1.4. Transportation to the site.

It is recommended to transport the UPS by means of a pallet jack or the most appropriate method considering the distance between the two points. If the distance is considerable, it is recommended to transport the device in its packaging to the installation site and then unpack it.

5.1.5. Siting, immobilising and considerations.

- All TWIN RT2 A series UPSs are designed to be mounted as a tower model - vertical arrangement of the device - or rack - horizontal arrangement - for installation in 19" cabinets, regardless of whether or not they have a battery module or whether the available backup is standard or extended (greater number of battery modules). Follow the instructions indicated in the sections relating to either of the two possibilities, according to the particular configuration of your device.
- Fig. 5 to 10 show, by way of example, illustrations of a device with or without battery module. These illustrations provide help and guidance on the steps to follow, but the instructions are not intended to refer to a single model, although, in practice, the actions to be carried out are always the same for all of them.
- For all instructions regarding connections, refer to section .

5.1.5.1. Rotation of the control panel with LCD.

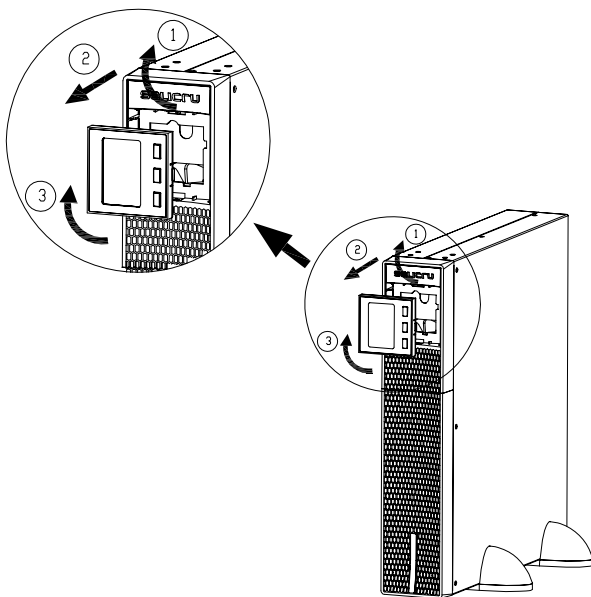

Fig. 5. Rotation of the control panel with LCD on the plastic front trim.

- To facilitate the reading of messages on the display when the device is installed vertically, it is possible to rotate the control panel clockwise by 90° (see).
- Likewise, reverse the rotation of the control panel if a device arranged as a tower needs to be installed as a rack. In this case, the rotation of the control panel will be anti-clockwise.
- Proceed as follows:
 - Insert fingertips into the recesses of the plastic trim around the display and pull outwards.
 - Rotate the control panel with LCD 90° to the right with respect to its initial position and insert it back into the front.

5.1.5.2. Vertical tower-type mounting.

- Rotate the control panel according to section .
- Take the 4 pieces of plastic supplied with the device and join them together in twos to obtain two bases.
- Place the UPS upright between the two bases at a distance of 70 mm from each end (see).



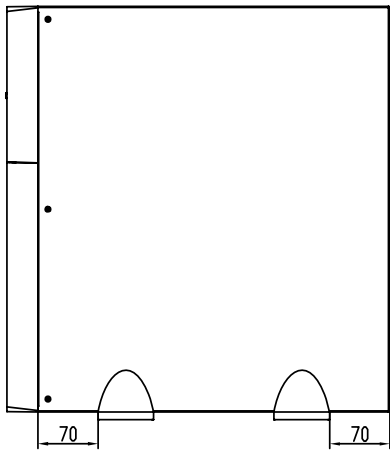

Fig. 6. Vertical tower-type mounting.

5.1.5.3. Vertical tower-type mounting with backup extension (battery module).

- The description in this section refers to a device with a single battery module. For a greater number, proceed in a similar way.
- Rotate the control panel according to section .
- Take the 4 plastic pieces in the form of an angle supplied with the UPS and the two supplied with the battery module, and install them to obtain two bases to hold the device and the battery module.
- Place the UPS and battery module upright between the two bases (see) and at a distance of 70 mm from each end, similar to as shown in .

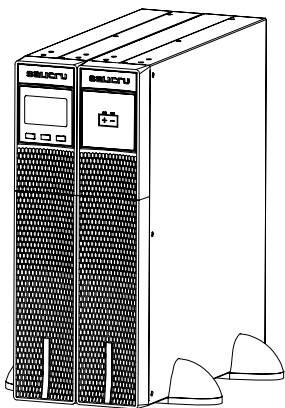

Fig. 7. Vertically mounted tower-type model with backup extension (battery module).

5.1.5.4. Mounting as a rack in a 19" cabinet.

- To mount a device in a 19" rack cabinet, proceed as follows (see):
 - Using the supplied screws, fix the two adapter angles for use as handles on each side of the UPS, respecting your hand.

- To install the device in a rack cabinet, it is necessary to have internal lateral guides for use as supports. Alternatively, and upon request, we can supply universal slides for use as guides, for installation by the user. Mount the guides at the required height, ensuring correct tightening of the fixing screws and appropriate fitting in the machining, according to each case.
- Place the device onto the guides and insert it all the way to the back. Depending on the device model and weight, and/or whether it is installed in the upper or lower part of the cabinet, it is recommended that two people carry out the installation operations.
- Fix the UPS to the cabinet frame using the screws supplied with the handles.

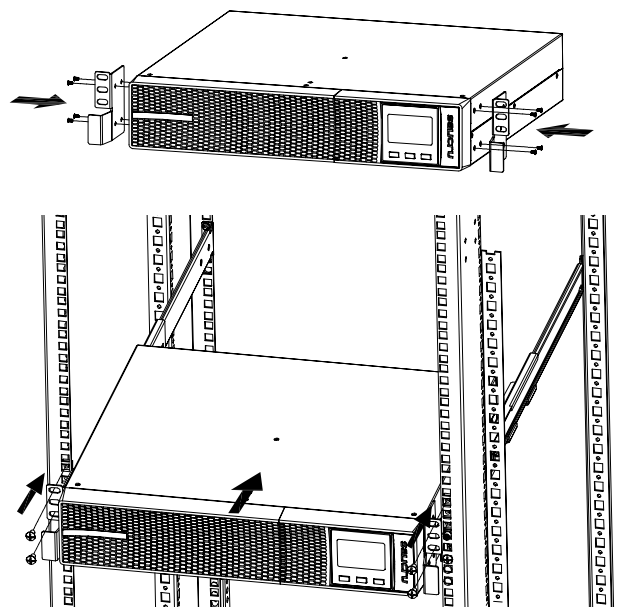

Fig. 8. Rack-type mounting in a 19" cabinet.

5.1.5.5. Rack mounting in a 19" cabinet with backup extension (battery module).

- This section describes a device with one battery module. For more battery modules, repeat the same procedure for each of them.
- To install a device and its battery module in a 19" rack cabinet, proceed as follows (see):
 - Using the supplied screws, fix the two adapter angles for use as handles on each side of the UPS, respecting your hand. Repeat the same procedure for the battery module.
 - To install each unit, UPS and battery module in a rack cabinet, it is necessary to have internal lateral guides for use as supports. Alternatively, and upon request, we can supply universal slides for use as guides, for installation by the user. Mount the guides at the required height, ensuring correct tightening of the fixing screws and appropriate fitting in the machining, according to each case.

- ❑ Place the device onto the guides and insert it all the way to the back. Proceed in the same way for the battery module.
Depending on the weight of each unit according to the type of device and battery module, and/or whether it is installed in the upper or lower part of the cabinet, it is recommended that two people carry out the installation operations.
- ❑ Fix the UPS and the battery module to the cabinet frame by means of the screws supplied with the respective handles.

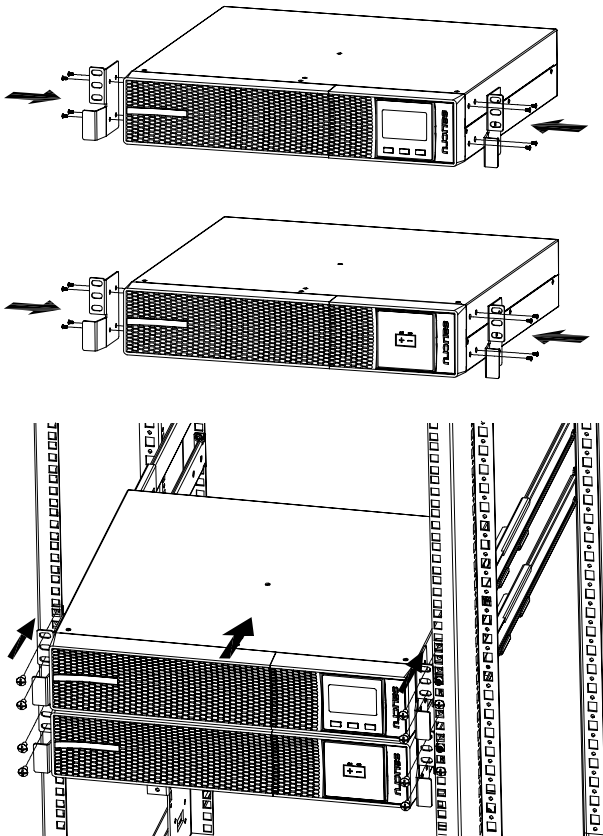



Fig. 9. Rack-mounted model in a 19" cabinet with backup extension (battery module).





5.1.5.6. Preliminary considerations before connection.

- In the description of this manual, reference is made to the connection of terminals and switch operations that are only available in some versions or devices with extended backup. Ignore the related operations if your unit does not feature them.
- Thermal control of these devices is carried out with the passage of forced air from the front to the rear.
The front surface and about 15 cm on the rear side should be left free of obstructions to facilitate the free circulation of air for ventilation.
- Follow and respect the instructions described in this section referring to installation.
- Protection or external manual bypass board:
 - ❑ The installation must have at least one short-circuit protection on the UPS's power supply line.
 - ❑ It is advisable to have an external manual bypass board fitted with input, output and manual bypass protections.

- Upon request, we can supply an external manual bypass board.
- The cross section of the cables must always be considered in relation to the size of the terminals of the switches, so that they are correctly fastened across their entire cross section for optimum contact between the two elements.
- Only rated currents are printed on the nameplate of the device. For calculation of the input current, the power factor and the device's own efficiency have been considered. Overload conditions are considered a non-permanent and exceptional working mode, and will not be taken into account in the application of the protections. Do not connect appliances or devices which may overload the UPS to the terminals and/or outlets, such as motors.
- It is recommended to install a two-pole D-curve circuit breaker at the input with the following currents depending on model:
 - ❑ 15 A for 1 kVA models.
 - ❑ 20 A for 2 kVA models.
 - ❑ 30 A for 3 kVA models.
- If peripheral input or output elements, such as transformers or autotransformers, are added to the UPS, the currents indicated on the nameplates of these elements must be taken into consideration when determining appropriate cross sections, in compliance with local and/or national low voltage electrotechnical regulations.
- When a galvanic isolation transformer is added to a UPS as standard, as an optional extra or independently, either on the input line, at the output or both, it must be fitted with protection against indirect contact (differential circuit breaker) at the output of each transformer, since, due to its own insulation properties, it will prevent the tripping of the protections placed on the primary of the isolation transformer in case of electric shock on the secondary (output of the isolation transformer).
- We remind you that all the isolation transformers installed or factory supplied, have the output neutral earthed through a jumper between the neutral terminal and earth. If the isolated output neutral is required, this jumper must be removed, taking the precautions indicated in the respective local and/or national low voltage regulations.
-  This device is suitable for installation in networks with TT, TN-S, TN-C or IT power distribution systems, taking into account at the time of installation the particularities of the system used and the national electrical regulations of the destination country.
- The SLC TWIN RT2 A features terminals for the installation of an external emergency power off button (EPO) or, failing that, a single device must be installed to cut the power supply to the loads in any operating mode.

5.1.5.7. Preliminary considerations before connection, regarding the batteries and their protections.

- SLC TWIN RT2 A devices from 1 to 3 kVA incorporate batteries both in the same enclosure as the device (standard backup) and in the external modules (extended backup).
- The battery protection of the device and of any accumulator module is always by means of internal fuses that are not accessible to the user.

-  **IMPORTANT FOR SAFETY:** If batteries are installed independently, the accumulator group must be fitted with a bipolar circuit breaker or disconnect fuse of the size indicated in .
- Inside the battery module, there are **HAZARDOUS VOLTAGES** with risk of electric shock, so it is classified as a **RESTRICTED ACCESS AREA**.
-  Do not handle the fuse holder or battery circuit breaker when the device is running.
-  If the mains power of the device is cut for longer than a simple intervention and it is expected that it will be out of service for a prolonged period time, the system must be shut down completely.
-  The battery circuit is not isolated from the input voltage. Dangerous voltages can occur between the terminals of the battery bank and the earth. Check that there is no input voltage before intervening on the terminals.

5.1.5.8. Connection elements.

- All of the device's electrical connections are made from the back of each unit:
 - Input and output connection.
 - Cable entry with integrated NEMA plug depending on model:
 - For 1 kVA devices, NEMA 5-15P plug.
 - For 2 kVA devices, NEMA 5-20P plug.
 - For 3 kVA devices, NEMA L5-30P plug.
 - Outputs through NEMA sockets, depending on model:
 - For devices up to 2 kVA, eight sockets.
 - For devices up to 3 kVA, nine sockets.
 - Connection to batteries.
 - The device and battery module have a polarised connector. Remove the screws and protective cover of the connector before interconnecting it.
 - All battery modules have two connectors that enable backup extension.
 - Communication connectors available:
 - DB9 for RS-232.
 - USB to operate the UPS as a PC peripheral.
 - For connection to external EPO button.
 - Slot for the integration of one of the optional electronic communication units. Remove the fixing screws and plastic cover to enable insertion.

5.2. CONNECTIONS.

5.2.1. Connection of the input.

- Plug the power cable into an AC power socket.

5.2.2. Connection of the NEMA output sockets.

- SLC TWIN RT2 A devices have female NEMA output sockets, distributed as follows depending on power:
 - Models up to 2 kVA. 2 groups of 4 NEMA 10 A sockets identified as 'OUTPUT' and 'OUTPUT PROGRAMMABLE (P1),' configurable through the control panel and/or ViewPower.



- 3 kVA models. Same number of sockets as the model up to 2 kVA and an additional 30 A NEMA socket.

-  Do not connect loads that in their entirety exceed the specifications of the device, as this would cause inconvenient cuts in the power supply of the loads connected to the output.
- If, in addition to the more sensitive 'critical loads,' it is necessary to connect high-consumption inductive loads, such as for laser printers or CRT monitors, the starting up of these peripherals will need to be taken into account to prevent the device from crashing. We do not recommend connecting loads of this type due to the amount of power they absorb from the UPS.

5.2.2.1. Connection of loads in models up to 3 kVA.



- Connect the loads to the 10 A NEMA sockets.
 -  It is important to consider the two groups of sockets available as those for 'critical loads' and those for 'non-critical loads'. By definition, 'critical loads' are considered to be those that can cause economic damage if they stop functioning or function incorrectly. The NEMA sockets indicated in as 'non-critical loads' can be programmed as such through the control panel. In this case, the backup of the batteries for the loads connected to the NEMA sockets indicated in as 'critical loads' will be reserved. Take into account that they are set by default as 'critical loads'.
- The 3 kVA models also have a 30 A NEMA socket that enables the connection of a load of the total power of the device.

5.2.3. Connection to external batteries (backup extension).

-  **Failure to comply with the instructions in this section and Safety Instructions EK266*08 carries a high risk of electric shock and even death.**
- All models incorporate batteries both in the same enclosure as the device (standard backup) and in the external modules (extended backup).
- The battery protection of the device and of any accumulator module is always by means of internal fuses that are not accessible to the user.
-  **IMPORTANT FOR SAFETY:** If batteries are installed independently, the accumulator group must be fitted with a bipolar circuit breaker or disconnect fuse of the size indicated in .

Model	Rated voltage of batteries	Minimum values, fast type fuses	
		DC voltage (V)	Current (A)
SLC-1000-TWIN RT2 B1 A	(12 V x 3) = 36 V	125	32
SLC-2000-TWIN RT2 B1 A	(12 V x 4) = 48 V		50
SLC-3000-TWIN RT2 B1 A	(12 V x 6) = 72 V		

Tab. 2. Protection features between device and battery module.

-  Before starting the connection process between battery module or modules and device, check that the device and loads are 'Off'. Also, when the batteries are installed by the user independently, the protection fuse or isolator must be deactivated.
- Connection of the battery module to the device is made by means of a cable featuring polarised connectors at both ends, which is supplied with the first one. Two connectors are available for this purpose on the device and battery module. Similarly, the battery modules feature two connectors that allow the linking of modules in parallel.
-  Each battery module is independent for each device. **Do not connect two devices to the same battery module.**
- shows the connection of a 3 kVA device in a rack arrangement with two battery modules. For a larger number, proceed in a manner similar to the illustration.

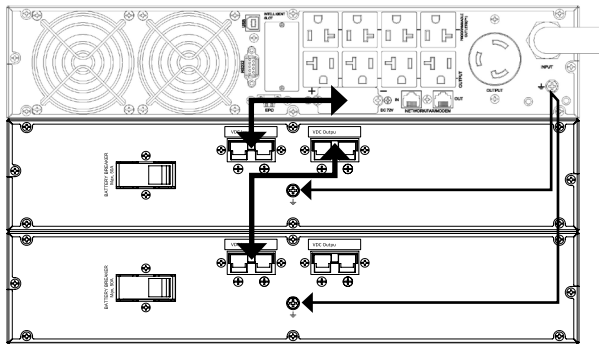



Fig. 10. Connection to battery modules.

-  As the device has class I protection against electric shock, it is essential for the AC input power socket to have the corresponding earth cable. Similarly, the device's earth terminal screw must be connected to that of the battery module or modules by cable.

5.2.4. Terminals for EPO (emergency power off).

- The UPSs have two terminals for the installation of an external emergency power off (EPO) output button.
- The device is dispatched from the factory with its EPO circuit set to closed (NC) by default. In other words, the UPS will cut the output power supply, emergency power off, when the circuit is opened:
 - Either by removing the female connector from the socket where it is inserted. This connector has a cable connected as a jumper that closes the circuit (see -A).
 - Or by pressing the button external to the device belonging to the user installed between the terminals of the connector (see -B). The connection on the button must be in the normally closed contact (NC), so it will open the circuit when activated.

The reverse functionality can be selected through the communications software and control panel.

Except for specific cases, we advise against this type of connection in view of the purpose of the EPO button, since it will not act upon an emergency request if either of the two cables that run from the button to the UPS is accidentally cut.

By contrast, this anomaly would immediately be detected in a closed EPO circuit, with the inconvenience of an unexpected cut in the powering of the loads, but a guarantee of effective emergency functionality.

- To recover the normal operating state of the UPS, it is necessary to insert the connector with the jumper in its receptacle or deactivate the EPO button. The device will be operational.

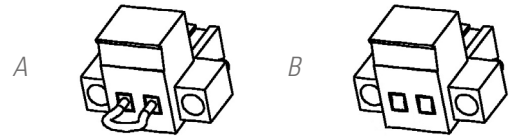



Fig. 11. Connector for external EPO.

5.2.5. Communications port.

5.2.5.1. RS-232 and USB port.

-  The communications line -COM- constitutes a very low voltage safety circuit. To preserve the quality, it must be installed separately from other lines carrying dangerous voltages (power distribution line).
- The RS-232 and USB interfaces are useful for the monitoring software and updating the firmware.
- It is not possible to use both the RS-232 and USB ports at the same time.
- The RS-232 port consists of the transmission of serial data in such a way that a large amount of information can be sent through a communication cable with only 3 wires.
- The USB port is compatible with the USB 1.1 protocol for communication software.

Pin #	Description	Input / Output
2	TXD for RS-232	Output
3	RXD for RS-232	Input
5	GND for RS-232	Earth

Tab. 3. Pinout of DB9 connector, RS-232.

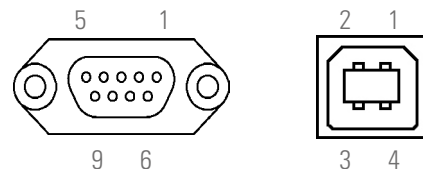

Fig. 12. DB9 connectors for RS-232 and USB.

5.2.6. Smart slot for the integration of an electronic communication unit.

- Optional electronic communication units include:
 - Relay interface to terminals, not programmable.
 - SNMP adapter.
 - RS-485 modbus adapter.
- The corresponding documentation is supplied with each option. Read it before starting installation.

Installation.

- Remove the protective cover from the device's slot.
- Take the corresponding electronic unit and insert it into the reserved slot. Make sure that it is properly connected, for which it is necessary to overcome the resistance caused in the connector located in the slot.
- Make the necessary connections in the terminal block or connectors available according to each case.
- Fit the new protective cover supplied with the relay interface card and secure it with the screws from the old cover.
- For more information, contact our **T.S.S.** or our nearest distributor.

5.2.7. Protection against voltage spikes for the modem / ADSL / fax, etc., line.

-  The communications line -COM- constitutes a very low voltage safety circuit. To preserve the quality, it must be installed separately from other lines carrying dangerous voltages (power distribution line).
- Connect the main line for the modem / ADSL / fax, etc., to the RJ45 connector of the device, identified as 'Input.'
- Connect the modem / ADSL / fax, etc., to the RJ45 connector of the device, identified as 'Output.'

5.2.8. Software.

• **Download of free ViewPower software.**

ViewPower is a UPS monitoring software which provides a user-friendly interface for monitoring and control. It features an auto shutdown function for systems consisting of several PCs in case of power failure. The software enables users to monitor and control any UPS in the same LAN through an RS-232 or USB communications port, regardless of how far away they are from each other.

• **Installation procedure:**

- Go to the web page:
<http://support.salicru.com>
- Select the required operating system and follow the instructions described on the web page to download the software.

5.2.9. Considerations before startup with connected loads.

-  It is recommended to charge the batteries for at least 12 hours before using the UPS for the first time.
 - For this, it will be necessary to supply voltage to the device and turn the circuit breaker at the back to 'On.' The battery charger will work automatically.
 - For the battery modules.
For the models with backup extension modules, it will also be necessary to set the fuse or circuit breaker of the batteries arranged between each one to 'On.'
- Although the device can operate correctly without charging the batteries for the specified 12 hours, the risk of a prolonged power cut during the first hours of operation and the UPS's available backup time should be assessed.
- Do not start up the device and loads completely until indicated in Chapter .
When it is done, however, it should be carried out gradually to avoid possible difficulties, at the very least, during the first startup.
- If, in addition to the more sensitive loads, it is necessary to connect high-consumption inductive loads, such as for laser printers or CRT monitors, the starting up of these peripherals will need to be taken into account to prevent the device from crashing.
For this type of load considered NON-PRIORITY, a group of programmable terminals is available depending on the model. Depending on the programming of these, the power supply may or may not be affected in the event of mains failure.

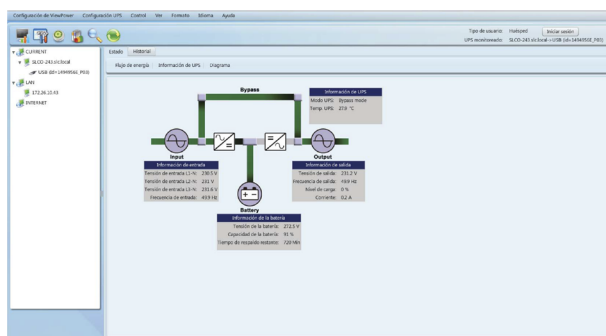



Fig. 13. View of ViewPower's main screen.

6. OPERATION.

6.1. STARTUP.

6.1.1. Checks before startup.

- Make sure that all of the connections have been made correctly and with sufficient tightening torque, following the instructions on the labelling of the device and in Chapter .
- Make sure that all loads are 'Off.'
 Shut down the connected loads before starting the UPS and start the loads, one by one, only when the UPS is running. Before shutting down the UPS, check that all of the loads are 'Off'.
- It is very important to proceed in the established order.
- For views of the UPS, see to .

6.2. UPS STARTUP AND SHUTDOWN.

6.2.1. UPS startup with mains voltage.

- Check that the power connection is correct.
- Supply voltage to the device (set the input protection of the distribution board or manual bypass to 'On').
- Set the battery switch to 'On' (extended backup models).
- Then the main start screen will be displayed after a test of the device.
- Press the 'ON' button for more than 2 seconds, the audible alarm will sound for 1 second and the UPS will start up.
- The UPS is set to 'Normal mode' after a few seconds. If the mains voltage is incorrect, the UPS will switch to 'Battery mode', without interrupting the power supply at the output terminals.
- Start the load or loads, making sure that the rated power of the device is not exceeded.

6.2.2. UPS startup without mains voltage.

- If it has a distribution board, set the input protection to 'On.'
- Set the battery switch to 'On' (extended backup models).
- Press the 'ON' button for more than 2 seconds, the audible alarm will sound for 1 second and the UPS will start up.
The fan or fans, depending on the model, will start to function.
Then the main start screen will be displayed after a test of the device.
- The UPS is set to 'Battery mode' after a few seconds.
Depending on the level of charge of the batteries, the residual backup available may be very limited. Consider the risk involved in operating without mains and discharged batteries.
If the mains voltage returns, the UPS will transfer to 'Normal mode' without interrupting the power supply at the output terminals.
- Start the load or loads, making sure that the rated power of the device is not exceeded.

6.2.3. UPS shutdown with mains voltage.

- Shut down the load or loads.
- Press the 'OFF' button for more than 2 seconds to shut down the inverter. The audible alarm will sound for 1 second. The device will be set to 'Bypass mode'.
 The output sockets will have voltage through the device's internal static bypass block.
- To cut the UPS's output voltage:
 - Remove the input plug from the power socket.
 - Or simply switch the input protection of the UPS's distribution board to 'Off.'A few seconds later, the LCD screen turns off and the entire device will be out of service.
- Set the battery switch to 'On' (extended backup models).

6.2.4. UPS shutdown without mains voltage.

- Shut down the load or loads.
- Press the 'OFF' button for more than 2 seconds to shut down the inverter. The audible alarm will sound for 1 second. The device will leave the output terminals without voltage.
A few seconds later, the LCD screen turns off and the entire device will be out of service.
- Set the battery switch to 'On' (extended backup models).
- To leave the assembly completely isolated, set the input switch on the board to 'Off.'

7. CONTROL PANEL WITH LCD.

7.1. GENERAL INFORMATION FOR THE SERIES.

7.1.1. Information represented by the display.

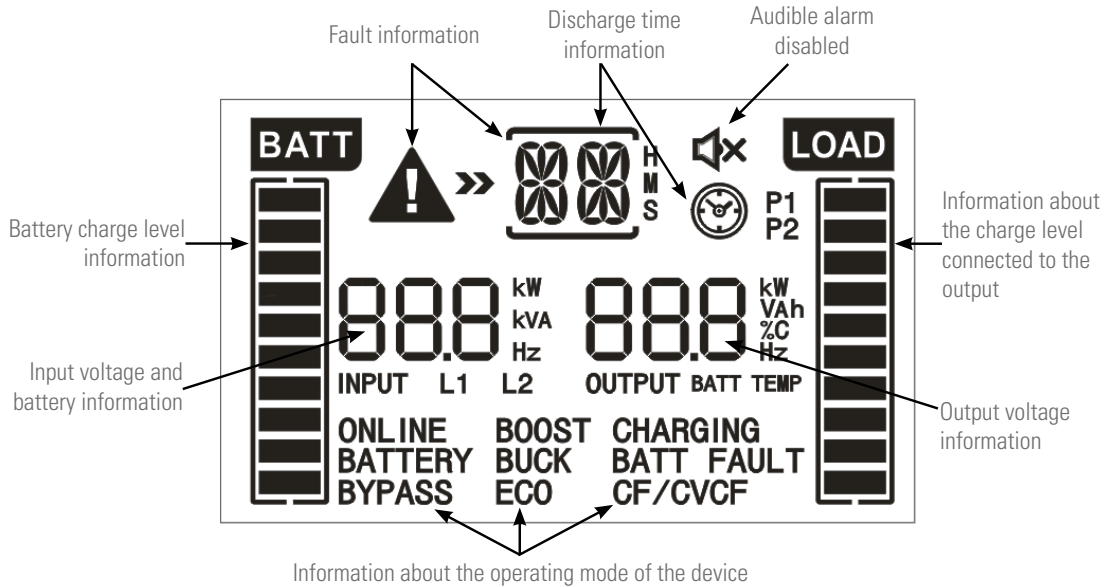

Fig. 14. Graphic and textual information shown on the display.

7.1.2. Common messages shown on the LCD display.

Display	Meaning
Backup time information.	
	Indicates the backup time in analogue clock mode.
	Indicates the backup time in digital clock mode. H - Hours, M - Minutes, S - Seconds.
Fault information.	
	Indicates as a warning that a fault has occurred.
	Indicates a numerical code from the settings menu shown in Table 13 of Section 7.2.4.4.
Audible alarm information.	
	Indicates that the audible alarm is disabled.
Information on output voltage.	
	Indicates the output voltage or frequency. V AC - Output voltage, Hz - Output frequency.
Information about the charge level connected to the output.	
	Indicates the charge level connected to the output as a %, by displaying four equivalent segments respectively in the following proportion: 0-25 %, 26-50 %, 51-75 % and 76-100 %.
Information about programmable outputs	
P1	Indicates that the programmable outputs are activated.

Information about the operating mode of the device.	
BATTERY	Indicates that the device is supplying output voltage from the battery (battery mode).
BYPASS	Indicates that the device is activated in BYPASS mode.
ECO	Indicates that the device is supplying output voltage from the bypass (ECO mode).
CHARGING	Indicates that the device is in charging mode.
CF/CVCF	Indicates that the device is in converter mode.
ONLINE	Indicates that the inverter is working.
P1	Indicates that the output is activated.
Information about battery charge level.	
	Indicates the battery charge level as a %, by displaying four equivalent segments respectively in the following proportion: 0-25 %, 26-50 %, 51-75 % and 76-100 %.
	Indicates that the battery is not connected.
	Indicates low battery voltage level.
Information about input and battery voltage.	
	Indicates the input voltage, frequency or battery voltage. V AC - Input voltage, V DC - Battery voltage, Hz - Input frequency.

Tab. 4. Information shown on the LCD panel of the control panel and its meaning.

7.1.3. Common abbreviations shown on the display.

Code	On display	Meaning
ENA	ENa	Enabled.
DIS	dIS	Disabled.
ATO	ATo	Automatic.
BAT	bAt	Battery.
NCF	nCF	Normal mode, working mode as UPS.
CF	CF	Working mode as frequency converter.
SUB	SuB	Subtract.
ADD	AdD	Add.
ON	ON	Startup.
OFF	OFF	Shutdown.
FBD	FbD	Not permitted.
OPN	OPN	Permitted.
RES	RES	Reserved.
N.L	n.L	Loss of neutral.
CHE	CHE	Check.
OP.V	OP.V	Output voltage.
PAR	PAR	Parallel, 001 refers to the first.
EPO	EP	Emergency power off.
FR	FR	Frequency.
OPL	OPL	Load percentage.
ESC	ESC	Escape.
HLS	HLS	Upper voltage limit for transfer to battery mode.
LLS	LLS	Lower voltage limit for transfer to battery mode.
AO	AO	EPO normally open.
AC	AC	EPO normally closed.
EAT	EAT	Estimated backup time.

Code	On display	Meaning
RAT	tAt	Current time in backup mode.
Ok	OK	Ok.
SD	Sd	Shutdown.
BL	bL	Battery low.
OL	OL	Overload.
OI	OI	Input overcurrent.
NC	NC	Battery not connected.
OC	OC	Battery overcharge.
SF	SF	Connection error. Rotate the connection of the input, phase and neutral cables.
TP	TP	Overtemperature.
CH	CH	Charger.
BF	bF	Battery failure, low voltage.
BV	bV	Bypass voltage out of range.
FU	FU	Bypass frequency out of range.
BR	bR	Replace batteries.
EE	EE	Internal EEPROM error.

Tab. 5. Abbreviations shown on the LCD.

7.2. CONTROL PANEL.

7.2.1. Composition of the control panel with LCD display.

- The control panel consists of:
 - Three buttons with the functions described in .
 - An LCD with backlighting.

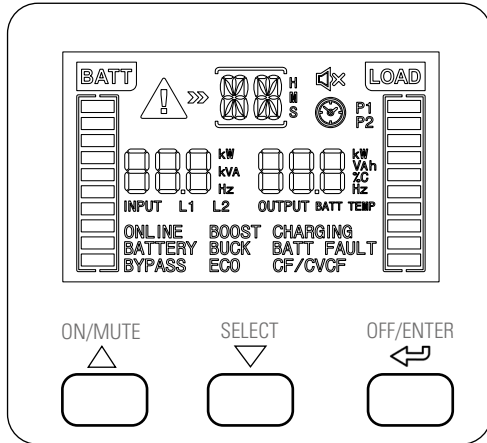

Fig. 15. View of the control panel.

Button	Description
ON/MUTE △	<ul style="list-style-type: none"> - Starting up the UPS. Press the button for at least 2 seconds. - Muting the alarm. Press the button for at least 3 seconds to mute or unmute the audible alarm. - Button to navigate upwards. When this button is pressed in UPS settings mode, it will move upwards through the menu structure in relation to the point where it is located, accessing the previous variable with each press. - Activating the battery test. Press this button for 3 seconds while in normal or frequency converter (CF) mode. At the end of the test, it returns to the respective mode.
SELECT ▽	<ul style="list-style-type: none"> - Settings or configuration mode. Press this button for at least 3 seconds to access this mode when the inverter of the UPS is shut down (bypass mode). - Button to navigate downwards. When this button is pressed in UPS settings mode, it will move downwards through the menu structure in relation to the point where it is located, accessing the following variable with each press.
OFF/ENTER ↩	<ul style="list-style-type: none"> - UPS shutdown. Press this button for at least 2 seconds. - Confirmation of selection. Press this button to confirm selection in the device's settings mode.

Tab. 6. Functionality of the control panel buttons.

7.2.2. Audible alarms.

Description	Alarm modulation or tone	Possibility of muting
State of the UPS		
Bypass mode	Beep every 10 second.	Yes
Battery mode	Beep every 5 second.	
Fault	Continuous.	No
Warning		
Overload	Beep every second.	Yes
End of backup	Beep every 1 second.	No
Faults		
All	Continuous.	No

Tab. 7. Audible alarms.

7.2.3. Location of the setting parameters on the display.

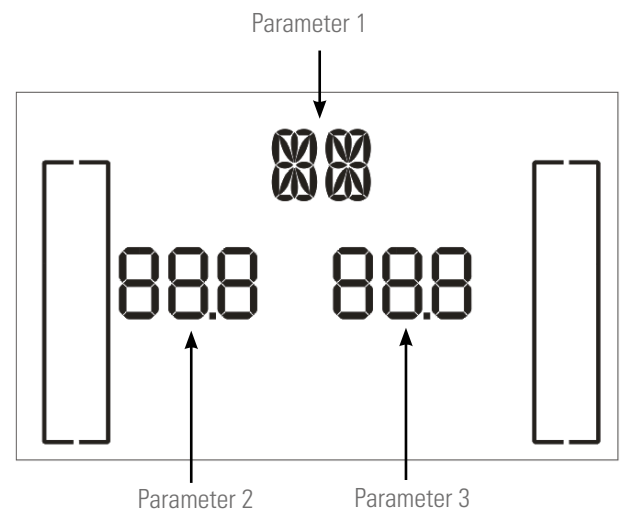

Fig. 16. Arrangement of the parameters on the LCD.

- Parameter 1: Code of the settings menu. For more information consult .
- Parameters 2 and 3 are the configuration or value options for each settings menu.
 - Select with buttons '▽' or '△' to modify the menus or parameters.
 - All of the parameter settings are saved when the UPS is completely shut down and provided that it has connected batteries, whether internal or external. If a complete shutdown is not carried out, the setting will not be saved to the memory.

7.2.4. Settings.

shows a summary of parameter 1's adjustable codes for each operating mode and shows the structure of the menu tree with the operating mode for the settings.

Code	Description	Bypass mode / No output mode	AC mode	ECO mode	CF mode	Battery mode	Battery test
01	Output voltage.	YES	-	-	-	-	-
02	Frequency converter state.	YES	-	-	-	-	-
03	Output frequency.	YES	-	-	-	-	-
04	ECO enable/disable mode.	YES	-	-	-	-	-
06	Bypass state (UPS 'Off').	YES	YES	-	-	-	-
09	Programmable output state.	YES	YES	YES	YES	YES	YES
10	Programmable output configuration.	YES	YES	YES	YES	YES	YES
11	Backup limitation configuration.	YES	YES	YES	YES	YES	YES
12	Total battery pack Ah configuration.	YES	YES	YES	YES	YES	YES
15	EPO logical configuration.	YES	YES	-	YES	YES	-
17	Viewable backup time configuration.	YES					

Tab. 8. Parameter 1 codes list. Description and settings

7.2.4.1. Ah configuration of parameter '12.'

- Standard models are configured with factory default settings, so it is not necessary to perform any actions to adjust this parameter.

For extended backup models, however, it is necessary to adjust the value to the total capacity of the battery pack. Any alteration of the battery pack will entail a readjustment, so it will be necessary to adapt the value in the event of future expansions.

- There are basically two reasons to perform the adjustment without it affecting the correct functioning of the device if it is not done, although it is more than recommended:

g. The charging current of the batteries is directly related to the capacity of the battery pack.

The charger will adapt the charging factor automatically according to the value of the total capacity entered, up to the maximum of the current that is possible.

This results in faster charging and therefore greater availability and more immediate backup in the event of frequent mains failures.

h. Entering the value in Ah is vital for the control to be able to calculate and show the backup available on the LCD, without further alterations.

The settings values are determined as follows:

- Devices with backup extension.

They are configured by a standard model plus the battery module or modules. The capacity of the batteries of both are indicated in the following and .

Example for an SLC 2000 TWIN RT2 A and backup extension module 698BU000003:

$$9 \text{ Ah} + 18 \text{ Ah} = 27 \text{ Ah (value for parameter 12).}$$

UPS model	Internal batteries	
	Voltage (V)	Capacity (Ah)
SLC 1000 TWIN RT2 A	36	7
SLC 2000 TWIN RT2 A	48	9
SLC 3000 TWIN RT2 A	72	

Tab. 9. Characteristics of batteries in standard devices.

Battery module		
Code	Voltage (V)	Capacity (Ah)
698BU000001	36	14 (2 x 7)
698BU000002	36	18 (2 x 9)
698BU000003	48	
698BU000004	72	

Tab. 10. Characteristics of batteries in modules.

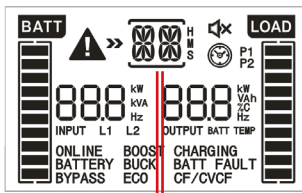

- The values indicated with(*) are factory default settings.
- The settings can only be made in 'byPA' or 'STby' mode.
- To carry out any modification of the configuration, follow the indicated sequence with the inverter necessarily Off.
- To exit the main menu from any position, press buttons ▽ + △ together.

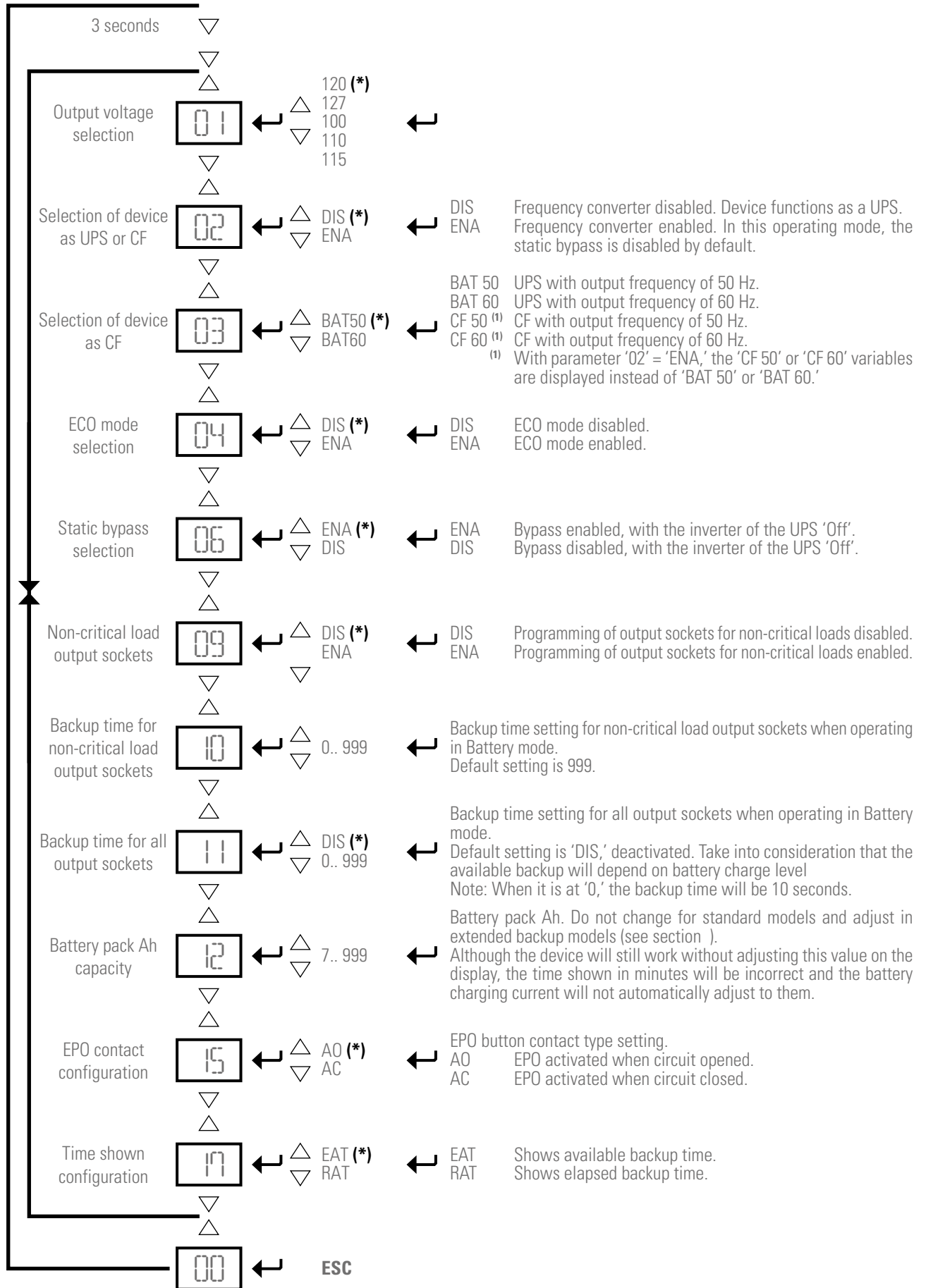
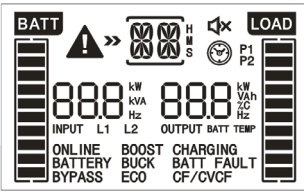
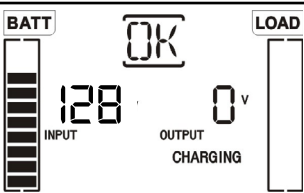
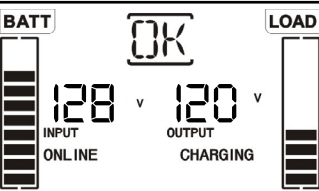
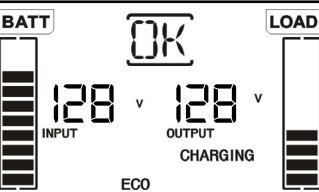
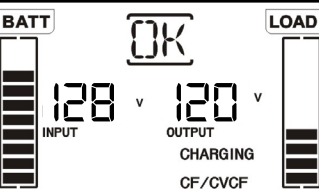
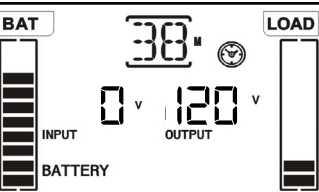
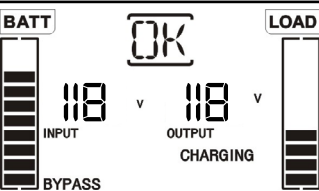

Fig. 17. Settings menu.

7.2.4.2. Operating mode / Description of state.

Operating mode / state		
UPS startup	Description. LCD.	When the UPS is started, the display screen of this mode is displayed for a few seconds to initialise the CPU and system. 
No output mode	Description. LCD.	The UPS is off and no output voltage is available, but it is charging the batteries. 
AC mode	Description. LCD.	If the input voltage is within the range of the device, the UPS will supply stable AC sine-wave voltage to the load or loads, and charge the batteries. 
ECO mode	Description. LCD.	If the input voltage is within the regulation ranges and ECO mode is activated, the UPS supplies the output voltage from the bypass in ECO mode (energy saving). 
CF mode	Description. LCD.	When the input frequency is between 46 and 64 Hz, the UPS can be set to a constant output frequency of 50 or 60 Hz. The device will still charge the batteries in this mode. 
Battery mode	Description. LCD.	Description: When the input / frequency voltage is not within the predefined range of the device or there is an AC mains failure, the UPS powers the loads from the batteries for a limited time due to their own capacity and activates the audible alarm modulated every 5 seconds. 
Bypass mode	Description. LCD.	When the input voltage is within the range but the UPS is overloaded, the system will automatically transfer to bypass mode or the transfer to this mode can be forced through the front panel. The audible alarm beeps every 10 seconds. 

Operating mode / state		
	Description.	When an error occurs, the ERROR icon and the fault code are displayed.
Error or fault state	LCD.	

Tab. 11. Operating modes.

7.2.4.3. Warning or alert codes.

Code	Warning or alert description
bL	Battery low
OL	Overload
OI	Input overcurrent
NC	Battery not connected
OC	Battery overcharge
SF	Input socket connection fault
EP	EPO enabled
TP	Overtemperature
CH	Charger fault
bF	Battery fault
bV	Static bypass voltage out of range
FU	Unstable static bypass frequency
bR	Replace batteries
EE	EEPROM error

Tab. 12. Warning or alert code.

7.2.4.4. Error or fault codes.

Code	Error or failure description
01	DC bus startup fault.
02	DC bus overvoltage.
03	DC bus undervoltage.
11	Inverter soft start fault
12	High voltage in the inverter
13	Low voltage in the inverter
14	Inverter output short-circuited
27	Battery voltage too high
28	Battery voltage too low
2A	Battery charger short-circuited at its output
41	Overtemperature
43	Output overloaded
45	Charger fault
49	Input overcurrent

Tab. 13. Error or fault code.

7.2.4.5. Warning or alert indicators.

Code	Icon (flashing)	Audible alarm
Low battery voltage.		Modulated every 2 seconds
Overload.		Modulated every second
Input overcurrent		Modulated twice every 10 seconds
Battery disconnected		Modulated every 2 seconds
Battery overcharge		Modulated every 2 seconds
Input socket connection fault		Modulated every 2 seconds
EPO enabled		Modulated every 2 seconds
Overtemperature		Modulated every 2 seconds
Charger fault		Modulated every 2 seconds
Battery fault	BATT FAULT	Modulated every 2 seconds (The UPS disconnects to warn the user that the batteries are incorrect).
Static bypass voltage out of range	BYPASS	Modulated every 2 seconds
Unstable static bypass frequency	BYPASS	Modulated every 2 seconds
Replace batteries		Modulated every 2 seconds
EEPROM error		Modulated every 2 seconds

Tab. 14. Warning or alert indicators.

8. MAINTENANCE, WARRANTY AND SERVICE.







8.1. BATTERY MAINTENANCE.

- Pay attention to all of the safety instructions concerning batteries indicated in section 1.2.3 of manual EK266*08.
- The service life of the batteries greatly depends on the ambient temperature and other factors such as the number of charges and discharges, as well as their depth. Their service life is designed to be between 3 and 5 years if the ambient temperature to which they are exposed is between 10 and 20°C. Different types of battery with different service lives are available upon request.
- SLC TWIN RT2 A series UPSs require minimum upkeep. The batteries used in the standard models are lead acid, sealed, valve regulated and maintenance free. The only requirement is to charge the batteries regularly to extend their life expectancy.
While the UPS is connected to the mains supply, whether or not it is running, it will keep the batteries charged and also offer protection from overcharging and deep discharge.

8.1.1. Notes for the installation and replacement of the battery.

- If it is necessary to replace any connection cables, original materials can be purchased through our **T.S.S.** or authorised distributors. Using inappropriate cables can lead to overheating in connections and fire hazards.
-  The inside of the device continues to have dangerous voltages even when there is no mains supply present due to the UPS's connection to batteries, especially if it has internal batteries, meaning that it is irrelevant if the input circuit breaker of the distribution board is 'Off.'
Also take into consideration that the battery circuit is not isolated from the input voltage, so there is a risk of discharge with dangerous voltages between the battery terminals and the earth terminal, which is in turn connected to earth (any metal part of the device).
- Repair and/or maintenance work must be carried out by our **T.S.S.**, except for the replacement of batteries, which can be performed by qualified personnel familiar with them. No other person should handle them.

8.2.1. Troubleshooting guide.

Symptom	Possible cause	Solution
No alarms or indications on the LCD and mains voltage normal.	The power cable is not connected correctly.	Check that the power cables are firmly connected to the mains.
Icon  and warning code  flash on the LCD and the audible alarm modulated every second is active.	The EPO function is activated.	Close the EPO signal circuit to deactivate it.
Icon  and warning code  flash on the LCD and the audible alarm modulated every two seconds is active.	Neutral to earth fault detection. Inverted phase and neutral input cables.	Disconnect input plug from AC power socket and invert connection of phase and supply neutral (rotate plug 180°).
Icon  and warning code  flash on the LCD and the audible alarm modulated every two seconds is active.	The internal or external batteries are badly connected	Check that all batteries are properly connected.

Depending on the configuration of the UPS, certain actions need to be carried out before handling the batteries:



- Shut down the loads and device completely.
- Disconnect the SLC TWIN RT2 A from the mains.
- In UPS models with integrated batteries:
 - Open the device to access the interior.
 - Remove the fuse or internal battery fuses.
- In devices with electronics and batteries in separate enclosures:
 - Disconnect the battery module from the UPS.
 - Open the battery module to access the interior.
 - Remove the fuse or internal battery fuses.
- Release the battery holders and replace the batteries.
- Perform the above steps in reverse to return the device to how it was at the start, including startup.

8.2. UPS TROUBLESHOOTING GUIDE.

If the UPS does not work properly, check the information shown on the LCD screen of the control panel and act accordingly depending on the device model.

Using the troubleshooting guide, try to resolve the issue and, if it persists, consult our Technical Service and Support **T.S.S.**, providing the following information:

- UPS model and serial number.
- Date on which the issue occurred.
- Full description of the issue, including information provided by the LCD or LEDs and state of the alarm.
- Power supply conditions, type of load and level of load applied to the UPS, ambient temperature, ventilation conditions.
- Battery information (capacity and number of batteries) if the device is standard or extended backup.
- Any other information considered relevant.

Symptom	Possible cause	Solution
Fault code 27 and the BATT FAULT message are shown on the LCD. The alarm sounds continuously.	Voltage of batteries too high or charger faulty.	Contact distributor or seller or, failing that, our T.S.S.
Fault code 28 and the BATT FAULT message are shown on the LCD. The audible alarm sounds continuously.	Voltage of batteries too low or charger faulty.	Contact distributor or seller or, failing that, our T.S.S.
Icon  , LOAD and warning code  flash on the LCD and the audible alarm modulated every second is active.	UPS overloaded.	Disconnect excess loads from output sockets.
	UPS overloaded. The connected loads are powered directly from the mains through the Bypass.	Disconnect excess loads from output sockets.
	After repeated overloads, the UPS is locked in Bypass mode. The connected loads are powered directly from the mains.	Disconnect the excess loads from the output sockets, shut down the device and restart it.
Fault code 49 is shown on the LCD. The audible alarm sounds continuously.	UPS input overcurrent.	Disconnect excess loads from output sockets.
Fault code 43 is shown on the LCD. The audible alarm sounds continuously.	The UPS shuts down automatically as a result of an overload in the output of the device.	Disconnect the excess loads from the output sockets and restart it.
Fault code 14 is shown on the LCD. The audible alarm sounds continuously.	The UPS shuts down automatically as a result of a short circuit in the output.	Check the output wiring and that the connected loads are not short-circuited
Fault codes 01, 02, 03, 11, 12, 13 and 41 are shown on the LCD. The audible alarm sounds continuously.	An internal fault has occurred in the UPS. This is due to one of two possibilities: 1. The load is still powered, but directly from the mains through the bypass. 2. The load is no longer powered.	Contact distributor or seller or, failing that, our T.S.S.
The backup time is shorter than expected.	The batteries do not charge completely.	Charge the batteries for at least 5 h and then check their charge state. If problem persists, contact distributor or seller or, failing that, our T.S.S.
	Faulty batteries.	Contact the distributor or seller or, failing that, our T.S.S. for battery replacement.
Fault code 2A is shown on the LCD. The audible alarm sounds continuously.	Charger short-circuited at its output.	Check whether the connection of the external battery pack connected to the UPS is short-circuited.
Fault code 45 is shown on the LCD. At the same time, the audible alarm sounds continuously.	The charger does not provide output and the battery voltage is less than 10 V per element.	Contact distributor or seller or, failing that, our T.S.S.

Tab. 15. Troubleshooting guide.

8.3. WARRANTY CONDITIONS.

8.3.1. Terms of the warranty.

On our website you will find the warranty conditions for the product you have purchased where you can also register it. It is recommended to do so as soon as possible to include it in the database of our Technical Service and Support (**T.S.S.**). Among other advantages, it will streamline any regulatory procedures for the intervention of **T.S.S.** in the event of a fault.

8.3.2. Exclusions.

Our company will not be bound by the warranty if it notices that the defect in the product does not exist or was caused by improper use, negligence, improper installation and/or verification, attempts at unauthorised repair or modification, or any other cause beyond the intended use, or by accident, fire, lightning or other hazards. Nor shall it cover any compensation for damages.

8.4. TECHNICAL SERVICES NETWORK.

Information about our national and international Technical Service and Support (**T.S.S.**) centres can be found on our website.

9. ANNEXES.

9.1. GENERAL TECHNICAL SPECIFICATIONS.

Models.	TWIN RT2 A		
Available power ratings (kVA / kW) ⁽¹⁾⁽²⁾	1 / 0,9	2 / 1,8	3 / 2,7
Technology.	On-line double-conversion, PFC, double DC bus.		
Rectifier.			
Input type.	Single-phase.		
Number of cables.	3 cables - Phase R (L) + Neutral (N) and earth.		
Rated voltage.	100 ⁽²⁾ / 110 / 115 / 120 / 127 V AC		
Input voltage range.	80.. 150 V AC with 100 % load.		
	55.. 150 V AC up to 60 % load.		
Frequency.	50 / 60 Hz (auto-detectable)		
Input frequency range.	± 10 Hz (40.. 60 / 50.. 70 Hz)		
Total harmonic distortion (THDi), at full load.	≤ 5 % (100.. 130 V AC)		
Power factor.	≥ 0.99 (at full load).		
Inverter.			
Technology.	PWM		
Waveform.	Pure sine wave.		
Power factor.	0,9		
Rated voltage.	100 ⁽²⁾ / 110 / 115 / 120 / 127 V AC ⁽¹⁾		
Output voltage accuracy (battery mode).	± 1 %		
Total harmonic distortion (THDv), with linear load.	< 2 %		
Frequency.	With mains present, synchronised to rated input (47.. 53 Hz).		
	With mains absent -backup mode- 50 / 60 ±0.1 Hz.		
Frequency synchronous speed.	< 1 Hz/sec.		
Transfer time, inverter to battery.	0 ms.		
Efficiency at full load, in line mode with battery 100% charged.	90 %	91 %	
Efficiency at full load, in ECO mode.	96% with charged batteries		
Overload in line mode.	110.. 130 %, 5 min.		
	> 130.. 140 %, 30 sec.		
	> 140.. 150 %, 1.5 sec.		
Overload in battery mode.	110.. 130 %, 2 min.		
	> 130.. 140 %, 10 sec.		
	> 140.. 150 %, 1.5 sec.		
Crest factor.	3:1		
Static bypass.			
Type.	Common line with mains. Mixed (thyristors in antiparallel + relay).		
Rated voltage.	That of the mains.		
Rated frequency.	That of the mains.		
Batteries.			
Type.	AGM or VRLA (sealed lead acid and maintenance-free)		
Element voltage.	12 V DC		
Capacity.	7 Ah	9 Ah	
Number of batteries in series / group voltage.	3 / 36 V DC	4 / 48 V DC	6 / 72 V DC
Blocking voltage for group end of backup.	31.5 V DC	42 V DC	63 V DC
Internal battery charger.			
Group fast charge voltage.	42.5 V DC	56.6 V DC	85 V DC
Group floating voltage.	41.0 V DC	54.7 V DC	82.1 V DC
Maximum charge current.	1, 2, 4, 6, 8 A adjustable		
Recharge time.	4 hours to 90 %		
Voltage / temperature compensation.	5 mV per battery / °C for temperature > 30 °C.		
Other functions.			
Cold start.	Yes		
Emergency power off.	Yes		
Frequency converter.	Yes ⁽²⁾		
General.			
Rated current input size	15 A.	20 A.	30 A.
NEMA output sockets.	8 x 10A sockets (4 not programmable for critical loads + 4 programmable) + 1 x 16A socket (only in 3 kVA UPS)		
Communications ports.	2 (DB9 RS-232 and USB, mutually exclusive).		
ADSL/fax/modem transient protector.	Yes (RJ45 connectors)		

Models.	TWIN RT2 A		
Available power ratings (kVA / kW) ⁽¹⁾⁽³⁾	1 / 0,9	2 / 1,8	3 / 2,7
Monitoring software.	ViewPower (free download).		
Optional cards (to insert in slot).	Relay interface, SNMP, remote Internet or intranet management.		
Noise level at 1 m.	< 50 dB		
Operating temperature.	0.. +40°C		
Storage temperature.	-20.. +50°C		
Working altitude.	2,400 masl (power degradation up to 5,000 m)		
Relative humidity of operation.	20.. 95% non-condensing.		
Protection rating.	IP20		
Dimensions (mm) -Depth x Width x Height- Standard UPS module Optional battery module.	410 x 438 x 88	510 x 438 x 88	630 x 438 x 88
Module height in number of U.	2		
Weight (kg). Standard UPS module. Optional battery module.	14.1 19.1	19.5 29	27.5 41.2
Safety.	UL1778		
Electromagnetic compatibility (EMC).	FCC Part 15, Subpart B, Class A		
Operation.	EN-IEC 62040-3		
Marking.	TÜV		
Quality system.	ISO 9001 and ISO 140001		

(1) The output power is limited depending on the maximum input current of the equipment according to the following table:

Power (VA)	Input I _{MAX} (A)
1000	12
2000	16
3000	24

In case of exceeding these current limits, the device reports this situation through the LCD display with the warning code "OI" (Over current input).

(2) 20% power derating when the output voltage is set to 100Vac.

(3) As a frequency converter, the power supplied will be 80% of the nominal.

Tab. 16. General technical specifications.

9.2. GLOSSARY.

- **AC.-** Alternating current is electric current in which the magnitude and direction vary cyclically. The waveform of the most commonly used alternating current is that of a sine wave, since this achieves a more efficient transmission of energy. In certain applications, however, other periodic waveforms are used, such as triangular or square.
- **Bypass.-** Manual or automatic, this is the physical connection between the input of an electrical device and its output.
- **DC.-** Direct current is the continuous flow of electrons through a conductor between two points with different potential. Unlike AC, in DC, electrical loads always circulate in the same direction from the point of greatest potential to the lowest. Although DC is commonly identified as a continuous current (for example, that supplied by a battery), any current that always maintains the same polarity is continuous.
- **DSP.-** Digital signal processor. A DSP is a processor or microprocessor-based system that has a set of instructions, hardware and optimised software for applications that require numerical operations at very high speed. Because of this, it is especially useful for the processing and represen-

tation of analogue signals in real time: in a system that works in this way (real time) samples are usually received from an analogue/digital converter (ADC).

- **Power factor.-** The power factor, PF, of an AC circuit is defined as the ratio between active power, P, and apparent power, S, or as the cosine of the angle formed by the current and voltage factors, designated in this case as cos ϕ , where ϕ is the value of the angle.
- **GND.-** This stands for GROUND or EARTH and, as the name indicates, refers to the potential of the surface of the Earth.
- **EMI filter.-** Filter capable of significantly reducing electromagnetic interference (EMI), which is the disturbance that occurs in a radio receiver or in any other electrical circuit caused by electromagnetic radiation coming from an external source. Electromagnetic interference is also known as radio frequency interference (RFI). This disturbance can interrupt, degrade or limit the performance of the circuit
- **IGBT.-** An insulated gate bipolar transistor is a semiconductor device that is generally used as a controlled switch in power electronics circuits. This device possesses the

characteristics of the gate signals of field effect transistors with the capacity for high current and low saturation voltage of the bipolar transistor, combining an isolated FET gate for input and control and a bipolar transistor as a single switch in a single device. The IGBT's excitation circuit is similar to that of the MOSFET, while the conducting characteristics are similar to those of the BJT.

- **Interface.-** In electronics, telecommunications and hardware, an interface (electronics) is the port (physical circuit) through which signals are sent or received from one system or subsystem to another
- **kVA.-** A volt-ampere is the unit used for apparent power in electrical current. In DC, it is practically equal to real power but, in AC, it can differ from this depending on the power factor.
- **LCD.-** Liquid crystal display, a device invented by Jack Janning, who was an employee of NCR. It is an electrical system for data presentation formed by 2 transparent conductive layers and a special crystalline material in the middle (liquid crystal) which have the ability to orientate light as it passes through.
- **LED.-** Light-emitting diode, a semiconductor device (diode) that emits light that is almost monochromatic, that is to say, it has a very narrow spectrum when it is polarised directly and is penetrated by an electric current. The colour (wavelength) depends on the semiconductor material used in the construction of the diode, and can vary from ultraviolet, passing through the visible light spectrum, to infrared, the latter called IRED (infra-red emitting diode).
- **Circuit breaker.-** A circuit breaker is a device capable of interrupting the electrical current of a circuit when it exceeds certain maximum values.
- **On-line mode.-** A device is said to be on-line when it is connected to a system, is operative, and normally has its power supply connected.
- **Inverter.-** An inverter is a circuit used to convert DC into AC. The function of an inverter is to change a DC input voltage to a symmetrical AC output voltage, with the magnitude and frequency desired by the user or designer.
- **Rectifier.-** In electronics, a rectifier is the element or circuit that converts AC into DC. This is done by using rectifier diodes, whether solid state semiconductors, vacuum valves or gaseous valves, such as those containing mercury vapour. Depending on the characteristics of the AC power that they use, they are classified as single-phase when they are powered by a mains phase or three-phase when they are powered by three phases. Depending on the type of rectification, they can be half wave when only one of the half cycles of the current is used or full wave when both half cycles are used.
- **Relay.-** A relay is an electromechanical device that functions as a switch controlled by an electrical circuit in which, by means of an electromagnet, a set of one or several contacts is activated to enable other independent electrical circuits to be opened or closed.
- **SCR.-** Silicon controlled rectifier, commonly known as a thyristor, a 4-layer semiconductor device that works as an almost ideal switch.
- **THD.-** Total harmonic distortion. Harmonic distortion occurs when the output signal of a system does not equal the signal that entered it. This lack of linearity affects the waveform

because the device has introduced harmonics that were not in the input signal. Since they are harmonic, that is to say, multiples of the input signal, this distortion is not so dissonant and is less easy to detect.

 .

A series of horizontal dotted lines for writing, starting from the first line below the scribble and extending to the bottom of the page.

SALICRU

Avda. de la Serra 100

08460 Palautordera

BARCELONA

Tel. +34 93 848 24 00

sst@salicru.com

SALICRU.COM



Information about the technical support and service network (TSS), the sales network and the warranty is available on our website:

www.salicru.com

Product range

Uninterruptible Power Supplies (UPS)

Power supplies

Variable frequency drives

Static inverters

Photovoltaic inverters

Voltage stabilisers



@salicru_SA



www.linkedin.com/company/salicru

SALICRU

