

IT M

Single-phase command and control transformers



IT M: Quality and versatility in low-power transformation

Salicru has been designing and manufacturing low-voltage electrical transformers for more than 50 years, both for use as an independent solution and as part of its wide range of power electronics solutions. The single-phase control transformers from its **IT M** series have been calculated and designed following the most stringent technical criteria, and tested using the most modern technologies. They are mainly used to adjust mains voltage levels and adapt them to that required by different applications in the industrial, tertiary and residential sectors.

They are also used as electrical insulation to power devices that need circuit separation, as well as to provide a safety voltage in locations that require it. The transformers from the **IT M** series are highly versatile thanks to their double or triple primary voltage and double secondary voltage, which is obtained by choosing between serial or parallel connection using the metal jumpers included.

Applications: Control, command, insulation and safety

The transformers from the **IT M** series fulfil four purposes required by a large variety of facilities: control, command, insulation and safety. Because of this, they can be used in many different applications in industrial, tertiary and residential sectors. They are widely used in the construction of electrical panels due to their compact size, ease of mounting and the flexibility offered by having several voltage sockets.

They supply a large amount of instantaneous power which enables the coils of contactors, relays, protections and other devices usually present on panels to be correctly magnetised.

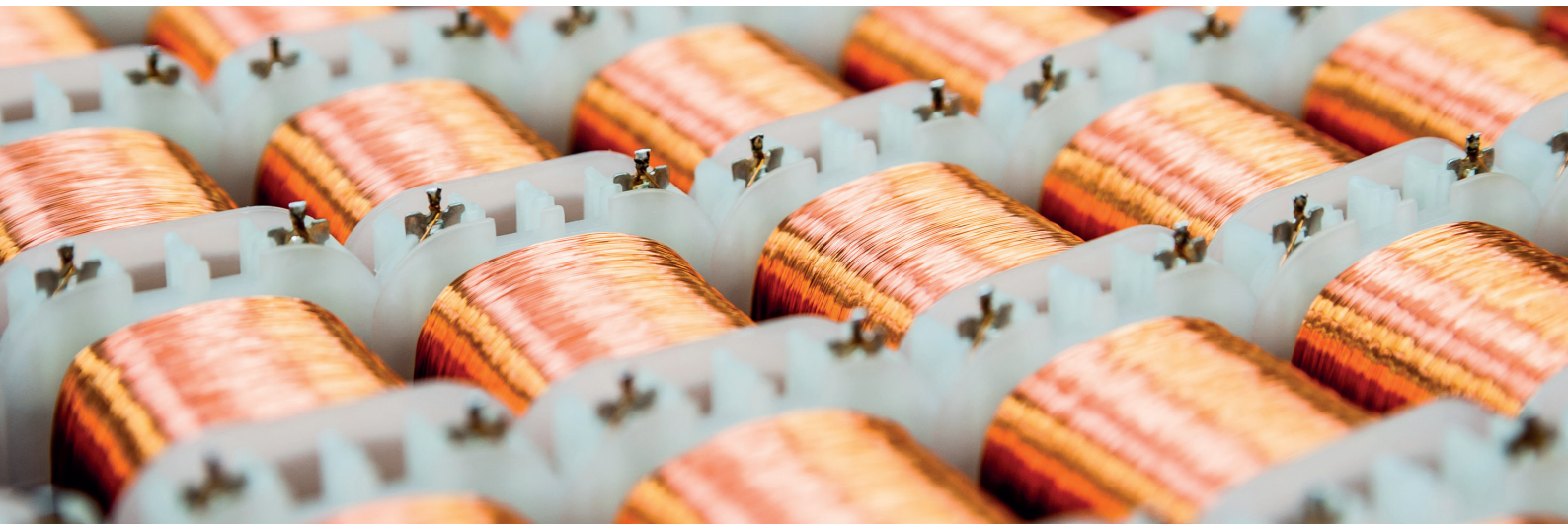

SALICRU

Performances

- Power range: 25 VA to 2000 VA.
- Typical input voltages up to 460 V.
- Voltage selection using jumpers included.
- Insulation class F (H for IP00 models).
- Insulation class HC windings.
- Connection group II0.
- Protection against electric shock Class I.
- Resin-impregnated copper windings.
- High-protection and anti-corrosive black resin finish.
- Windings protected by self-extinguishing housing with adapter for DIN rail up to 250 VA (IP20 models).
- Tropicalised.
- Low heat loss.
- Low weight and compact dimensions.

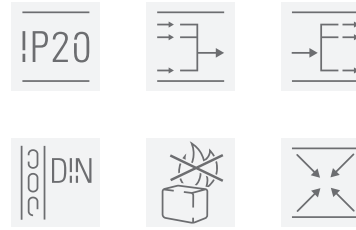

Connection diagram 1

- Input iA: 230 V – 400 V
- Output oR: 12 V (V1) – 24 V (V2)
- Output oS: 24 V (V1) – 48 V (V2)
- Output oT: 115 V (V1) – 230 V (V2)

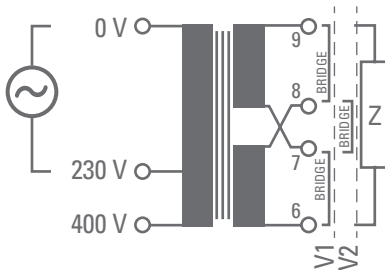

Connection diagram 2

- Input iB: 230 V – 400 V - 460 V
- Output oR: 12 V (V1) – 24 V (V2)
- Output oS: 24 V (V1) – 48 V (V2)
- Output oT: 115 V (V1) – 230 V (V2)

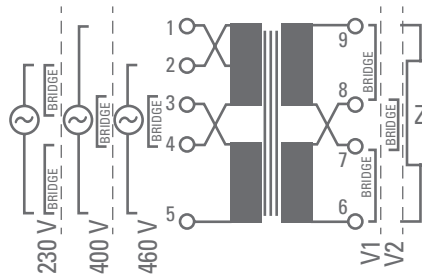

Connection diagram 3

- Input iB: 230 V – 400 V - 460 V
- Output oR: 12 V (V1) – 24 V (V2)
- Output oS: 24 V (V1) – 48 V (V2)
- Output oT: 115 V (V1) – 230 V (V2)

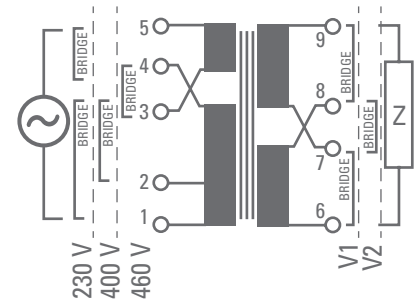

Range

MODEL	POWER (VA)	INPUT VOLTAGE	OUTPUT VOLTAGE	PRESENTATION
IT M-# E iAoR	25 ÷ 100	230 - 400 V	12 -24 V	Encapsulated IP20 / Diagram 1
IT M-# E iBoR	160 ÷ 800	230 - 400 - 460 V	12 -24 V	Encapsulated IP20 / Diagram 2
IT M-# E iAoS	25 ÷ 100	230 - 400 V	24 - 48 V	Encapsulated IP20 / Diagram 1
IT M-# E iBoS	160 ÷ 1300	230 - 400 - 460 V	24 - 48 V	Encapsulated IP20 / Diagram 2
IT M-# TC iBoS	1600 ÷ 2000	230 - 400 - 460 V	24 - 48 V	IP00 / Diagram 3
IT M-# E iAoT	25 ÷ 100	230 - 400 V	115 - 230 V	Encapsulated IP20 / Diagram 1
IT M-# E iBoT	160 ÷ 1300	230 - 400 - 460 V	115 - 230 V	Encapsulated IP20 / Diagram 2
IT M-# TC iBoT	1600 ÷ 2000	230 - 400 - 460 V	115 - 230 V	IP00 / Diagram 3

For other powers, voltages and/or presentations, please enquire.

Dimensions



IT M-25÷100 E iAoR
IT M-25÷100 E iAoS
IT M-25÷100 E iAoT



IT M-160/200 E iBoR
IT M-160/200 E iBoS
IT M-160/200 E iBoT



IT M-250÷400 E iBoR
IT M-250÷400 E iBoS
IT M-250÷400 E iBoT



IT M-500/630 E iBoR
IT M-500/630 E iBoS
IT M-500/630 E iBoT



IT M-800÷1300 E iBoR
IT M-800÷1300 E iBoS
IT M-800÷1300 E iBoT

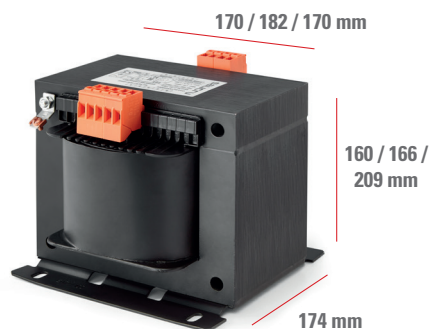

IT M-1600/2000 TC iBoS
IT M-1600/2000 TC iBoT

Technical specifications

MODEL		IT M
ELECTRICAL	Input/Output	Single-phase
	Power range	25 VA a 2000 VA
	Power factor	1
	Connection group	li0 (with jumpers)
INPUT	Single phase voltage	Pow ≤ 100 VA: 230-400 V / Pow > 100 VA: 230-400-460 V
	Rated frequency	50 / 60 Hz
OUTPUT	Single phase rated voltage	12-24 V (separation of circuits and safety) / 24-48 V (separation of circuits and safety) / 115-230 V (separation of circuits)
	Frequency	50 / 60 Hz
	Single phase short-circuit voltage	25 VA: 6,7%; 100 VA: 5,9%; 250 VA: 4,9% 500 VA: 3,3%; 1000 VA: 2,7%; 2000VA: 2%
MANUFACTURE	Insulators	Insulation class F (140°C) Temp=40°C for models with protection rating IP20 Insulation class B (120°C) Temp=45°C for models with protection rating IP00
	Windings	Insulation class H (200°C)
	Windings material	Copper
	Impregnation	Synthetic and polymerised resin
	Ventilation	ANAN
GENERAL	Version	Pow ≤ 1300 VA (≤ 800 VA for 12-24 V output): Windings protected by self-extinguishing housing with adapter for DIN rail up to 250 VA. Pow > 1300 VA (> 800 VA for 12-24 V output): Base plate according to DIN 41308. High-protection, anti-corrosive and tropicalised black resin finish.
	Colour (box version)	Black with orange terminals
	Electrical protection	Against electric shock Class I
	Degree of protection	IP20 for Pow ≤ 1300 VA (≤ 800 VA for 12-24 V output) / IP00 for Pow > 1300 VA (> 800 VA for 12-24 V output)
	Test voltage	4.5 kV pri-sec - 2.5 kV sec-earth
	Terminal type	Screw terminals
STANDARDS	Safety	EN-61558- Directive 2006/95CEE UNE20324-EN60529
	Quality and environmental management	ISO 9001 & ISO 14001

Information subject to change without notice.