

**DC POWER SUPPLY DEVICE.
THYRISTOR-CONTROLLED CHARGER RECTIFIER 25.. 800 A.**



DC POWER-L Series



General index

1. Introduction.

1.1. Thank you letter.

2. Safety information.

2.1. Using this manual.

2.1.1. Conventions and symbols used.

3. Quality assurance and standards.

3.1. Statement by the management.

3.2. Standards.

3.3. UKCA Product mark and UK Authorized representative.

3.4. Environment.

4. Presentation.

4.1. Views of the devices.

4.1.1. Dimensional drawings.

4.1.2.

Device views key.

4.1.3.

Nomenclature.

5. Rectifier block diagram and description.

5.1. Block diagram.

5.2. Description.

5.2.1. General.

5.2.2. AC input.

5.2.3. Input filter.

5.2.4. Transformer.

5.2.5. Bridge rectifier.

5.2.6. Battery.

5.2.7. Output filter.

5.2.8. DC output.

5.2.9. Control/Display.

5.2.9.1. Control.

5.2.9.10. Relay Interface.

5.2.10.1.

Electronic unit for NIMBUS remote maintenance (optional).

5.2.11. Protection.

5.3. Management of batteries and charging levels.

5.3.1. Charging levels.

5.3.1.1. Floating

5.3.1.2. Quick charge.

5.3.1.3. Exceptional charging.

5.3.2. Charging type priorities.

5.3.2.1. Activation and deactivation of charging types.

6. Device reception.

6.1. Reception and unpacking.

6.2. Packing list and contents.

6.3. Storage.

7. Installation.

7.1. Look after your safety.

7.2. Considerations to take into account.

7.3. Earth connection, terminal or strip (X5) and/or (X5A).

7.4. Connection of the system to the cabinet or battery bank. Terminals (X11) - (X12) and (X47) - (X48).

7.5. Connection to the main AC power supply network. Terminals (X1) and (X4) or (X1), (X2) and (X3) for single or three-phase.

7.6. Connection to the auxiliary AC power supply network. Terminals (X1A) and (X4A).

7.7. Connection of the loads to DC output terminals (X6) and (X9).

7.7.1. Floating output.

7.7.2. Output with positive connected to earth.

7.7.3. Output with negative connected to earth.

7.8. Useful for the TSS maintenance services (X37) (optional).

7.9. Connection of auxiliary terminals (X43) and (X43A). Optional auxiliary contacts block (F/Q8).

7.10. Optional electrolyte level sensor, terminal (X25A).

7.11. COM communications module (optional).

8. Rectifier startup and shutdown.

8.1. Startup procedure

8.2. Shutdown procedure.

9. Control panel.

9.1. Optical indications and alarm.

9.2. Basic functions of the keys and notes of interest.

9.3. Description of the screens.

9.3.1. 'Home' screen menu.

9.3.2. 'Measurements' menu.

9.3.3. 'Manoeuvres' menu.

9.3.4. 'User Parameters' menu.

9.3.5. 'Alarms' menu.

9.3.6. 'Battery Settings' menu.

9.3.7. 'Rectifier Settings' menu.

9.3.8. 'Password' menu.

10. Maintenance.

10.1. Basic maintenance guide.

10.1.1. Batteries.

10.1.2. Capacitors.

10.2. Warranty conditions.

10.2.1. Terms of the warranty.

10.2.2. Exclusions.

10.3. Technical services network.

11. Annexes.

11.1. General technical specifications.

11.2. Glossary.

1. Introduction.

1.1. Thank you letter.

We thank you in advance for the trust placed in us in the purchasing of this product. Read this instruction manual carefully in order to familiarise yourself with its content, since the more you know and understand the device the greater your satisfaction, level of safety and optimisation of its functionalities will be.

We remain at your disposal for any additional information or queries that you may wish to make.

Yours sincerely,

SALICRU

- The device described here **is capable of causing significant physical injury if improperly handled**. For this reason, its installation, maintenance and/or repair must be carried out exclusively by our staff or by **qualified personnel**.
- Although no effort has been spared to ensure that the information in this user manual is complete and accurate, we accept no liability for any errors or omissions that may exist.

The images included in this document are for illustrative purposes and may not exactly represent the parts of the device shown. However, any divergence that may arise will be remedied or solved with the correct labelling on the unit.
- Following our policy of constant evolution, **we reserve the right to modify the characteristics, operations or actions described in this document without prior notice**.
- Any **reproduction, copying, assignment to third parties, amendment or total or partial translation** of this manual or document, in any form or by any means, **without the prior written permission of Salicru is prohibited**, with the company fully and exclusively reserving its ownership rights over it.

2. Safety information.

2.1. Using this manual.

- The purpose of the DC Power-L documentation is to provide information regarding safety and explanations of the procedures for installation and operation of the device.

The device's generic documentation is supplied in digital format on a Pendrive and it includes, among other documents, the system's user manual and that of other constituent parts, such as the communications module.

- Supplied with this user manual and included in the same documentation Pendrive is the EK266*08 '**Safety instructions**' document.

Before carrying out any action on the device relating to its installation or startup, change of location, configuration or handling of any kind, carefully read the safety instructions.



Compliance with the 'Safety Instructions' is obligatory, with the user being legally responsible for observing and applying them. Read it carefully and follow the steps indicated in the order established.

- The device is delivered properly labelled for correct identification of each of its parts, which, together with the instructions described in this user manual, allows installation and startup operations to be performed in a simple and organised manner without any doubts whatsoever.

Finally, once the device is installed and operating, it is recommended to keep the documentation Pendrive in a safe and easy-to-access location for future reference.

- If a system differs from that shown in the figures in Chapter 4 due to implementing or excluding elements or parts and/or amending the technical specifications, additional explanatory annexes will be published if considered appropriate or necessary. These will usually be printed on paper.
- The following terms are used interchangeably in the document to refer to:

- '**DC Power-L,** '**device,** '**charger rectifier,** '**system,** '**DC power system** or '**unit**' - DC power supply device.

Depending on the context of the term, it can interchangeably refer to the charger rectifier assembly itself or to the device with batteries, regardless of whether they are all contained in the same cabinet.

- '**Batteries** or '**accumulators**' - Bank or set of elements that stores the flow of electrons by electrochemical means.
- '**TSS**' - Technical Service and Support.
- '**User** or '**customer**' - These are used interchangeably and by extension to refer to the installer and/or operator who carries out the corresponding actions, with the same person possibly being responsible for carrying out the respective actions when acting on behalf, or in representation, of the above.

2.1.1. Conventions and symbols used.

Some symbols may be used and appear on the device, batteries and/or in the context of the user manual.

For more information, see Section 1.1.1 of the '**Safety Instructions**' document EK266*08.

3. Quality assurance and standards.

3.1. Statement by the management.

Our goal is customer satisfaction, therefore this Management has decided to establish a Quality and Environment Policy, through the implementation of a Quality and Environmental Management System that will enable us to comply with the requirements demanded in the **ISO 9001** and **ISO 14001** and also by our Customers and Stakeholders.

Likewise, the management of the company is committed to the development and improvement of the Quality and Environmental Management System, through:

- Communication to the entire company of the importance of satisfying both the customer's requirements as well as legal and regulatory requirements.
- The dissemination of the Quality and Environment Policy and the setting of the Quality and Environment objectives.
- Conducting reviews by the Management.
- Providing the necessary resources.

3.2. Standards.

The **DC Power-L** is designed, manufactured and sold in accordance with Quality Management Systems standard **EN ISO 9001** and is certified by the company SGS. The **CE** marking indicates conformity with EC Directives through the application of the following standards:

- **IEC/EN 61204-7**. - Low-voltage power supplies, d.c. output. Part 7: Safety requirements.
- **IEC 60146-1-1**. - Semiconductor converters - General requirements and line commutated converters - Part 1-1: Specification of basic requirements.
- **IEC/EN 61204-3**. - Low-voltage power supply devices, d.c. output. Part 3: Electromagnetic compatibility.



The manufacturer is not liable in the event of modification or intervention on the device by the user.



This is a Class A device. In residential, commercial or light industry environments, it may cause radio interference. This device is not intended to be installed in a residential, commercial or light industry environment. In the event of connection to the public electricity supply, the user may be required to take all appropriate measures to reduce interference.



The product's CE declaration of conformity is available to the customer upon express request to our head office.

3.3. UKCA Product mark and UK Authorized representative.

UK CA product marking indicates that this UPS has been evaluated by Salicru and is deemed to comply with safety, health and environmental protection requirements.

The UK CA Declaration of Conformity is available upon request. For copies of the UKCA Declaration of Conformity, please contact Salicru or check our website: www.salicru.com.

UK Authorised Representative
Indele Limited
7 Bell Yard,
WC2A 2JR,
London

3.4. Environment.

This product has been designed to respect the environment and manufactured in accordance with **ISO 14001**.

Recycling of the device at the end of its useful life:

Our company undertakes to use the services of authorised and regulatory companies to treat the set of products recovered at the end of their useful life (contact your distributor).

Packaging:

To recycle the packaging, please comply with any legal requirements in force.

Batteries:

Batteries pose a serious danger to health and the environment. The disposal of them shall be carried out in accordance with the laws in force.

4. Presentation.

4.1. Views of the devices.

Table 1 shows the standardised models of the DC Power-L series.

The illustrations in Fig. 2, 4, 5 and 6 are representative of the range of standard models in the DC Power-L series. They reflect the external and internal physical arrangement of each of the two standardised cabinets and only the elements of use to the user, such as the connection terminals and the operating switches. With the same criteria, Figures 3 and 7 represent the views of the battery cabinet.

The size or format of the protections and terminals shown in the figures will vary depending on the power and/or output voltage of the device, but its physical arrangement in relation to the whole cabinet will remain the same. The same goes for the views of the battery cabinet, which are generic and do not contain the accumulators, since these will be installed once the cabinet or cabinets are placed in their final location.

By default, the device is of the type that has floating output and its protections are two-pole. For requested outputs referenced with positive or negative to earth, the protection will always be single-pole so as not to disconnect the pole from earth.

The entry of connection cables is through the base of the cabinet. Optionally and on request, cable entry can be through the top cover, with a conduit for the cables down to the area of the terminals. In both cases, the connection elements will always be arranged in the lower part of the cabinet.

If any of the referenced components is not included on your unit, disregard any description or action on it, and if the device features parts not described in this manual, additional explanatory annexes will be published if necessary. The device will however be delivered with proper labelling, to which full attention will need to be paid.

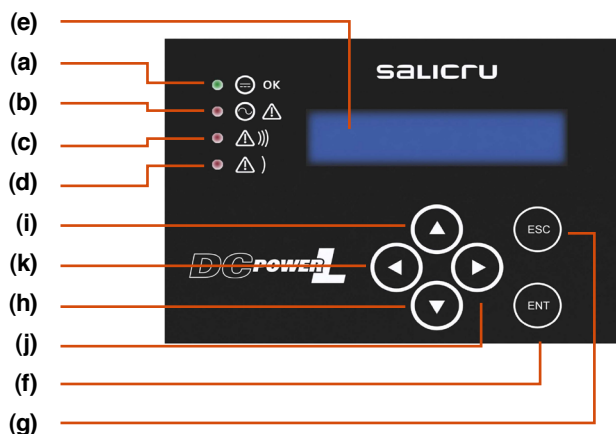

Fig. 1. View of the control panel.

Model	Voltage		Charger Current (A)	Cabinet		Total No.		
	Input (Vac)	output (Vdc)		Dimensions ⁽¹⁾ Depth x Width x Height (mm)				
				Rectifier	Batteries			
DC-25-L 24	3 x 230 / 3 x 400 (3F + N)	24	25	640 x 630 x 1200	-	1		
DC-50-L 24			50	640 x 630 x 2000				
DC-75-L 24			75	640 x 830 x 2000				
DC-100-L 24			100					
DC-150-L 24			150					
DC-200-L 24			200	640 x 830 x 2000			1 + 1	
DC-250-L 24			250	840 x 830 x 2000			840 x 830 x 2000	1 + 1
DC-300-L 24			300					
DC-350-L 24			350					
DC-400-L 24			400					
DC-450-L 24			450					
DC-500-L 24			500					
DC-600-L 24			600					
DC-700-L 24			700					
DC-800-L 24			800					
DC-25-L 48			3 x 230 / 3 x 400 (3F + N)	48	25	640 x 630 x 1200	-	1
DC-50-L 48	50	640 x 630 x 2000						
DC-75-L 48	75	640 x 830 x 2000						
DC-100-L 48	100							
DC-150-L 48	150							
DC-200-L 48	200	640 x 830 x 2000			1 + 1			
DC-250-L 48	250	840 x 830 x 2000			840 x 830 x 2000	1 + 1		
DC-300-L 48	300							
DC-350-L 48	350							
DC-400-L 48	400							
DC-450-L 48	450							
DC-500-L 48	500							
DC-600-L 48	600							
DC-700-L 48	700							
DC-800-L 48	800							
DC-25-L 110	3 x 230 / 3 x 400 (3F + N)	110			25	640 x 630 x 1200	-	1
DC-50-L 110			50	640 x 630 x 2000				
DC-75-L 110			75	640 x 830 x 2000				
DC-100-L 110			100					
DC-150-L 110			150					
DC-200-L 110			200	640 x 830 x 2000	1 + 1			
DC-250-L 110			250	840 x 830 x 2000	840 x 830 x 2000	1 + 1		
DC-300-L 110			300					
DC-350-L 110			350					
DC-400-L 110			400					
DC-450-L 110			450					
DC-500-L 110			500					
DC-600-L 110			600					
DC-700-L 110			700					
DC-800-L 110			800					

DC-25-L 125	3 x 230 / 3 x 400 (3F + N)	125	25	640 x 630 x 1200	-	1		
DC-50-L 125			50	640 x 630 x 2000				
DC-75-L 125			75	640 x 830 x 2000				
DC-100-L 125			100					
DC-150-L 125			150	640 x 830 x 2000	640 x 830 x 2000	1 + 1		
DC-200-L 125			200					
DC-250-L 125			250	840 x 830 x 2000	840 x 830 x 2000	1 + 1		
DC-300-L 125			300					
DC-350-L 125			350					
DC-400-L 125			400					
DC-450-L 125			450	840 x 1230 x 2000	840 x 830 x 2000	1 + 1		
DC-500-L 125			500					
DC-600-L 125			600					
DC-700-L 125			700					
DC-800-L 125			800					
DC-25-L 220			3 x 230 / 3 x 400 (3F + N)	220	25	640 x 630 x 2000	-	1
DC-50-L 220					50	640 x 830 x 2000		
DC-75-L 220	75	840 x 830 x 2000						
DC-100-L 220	100	640 x 830 x 2000			640 x 830 x 2000	1 + 1		
DC-150-L 220	150							
DC-200-L 220	200							
DC-250-L 220	250	840 x 830 x 2000			840 x 830 x 2000	1 + 1		
DC-300-L 220	300							
DC-350-L 220	350							
DC-400-L 220	400							
DC-450-L 220	450	840 x 1230 x 2000			840 x 830 x 2000	1 + 1		
DC-500-L 220	500							
DC-600-L 220	600							
DC-700-L 220	700							
DC-800-L 220	800							

⁽¹⁾ Dimensions without optional feet

Table 1. *Standardised models.*

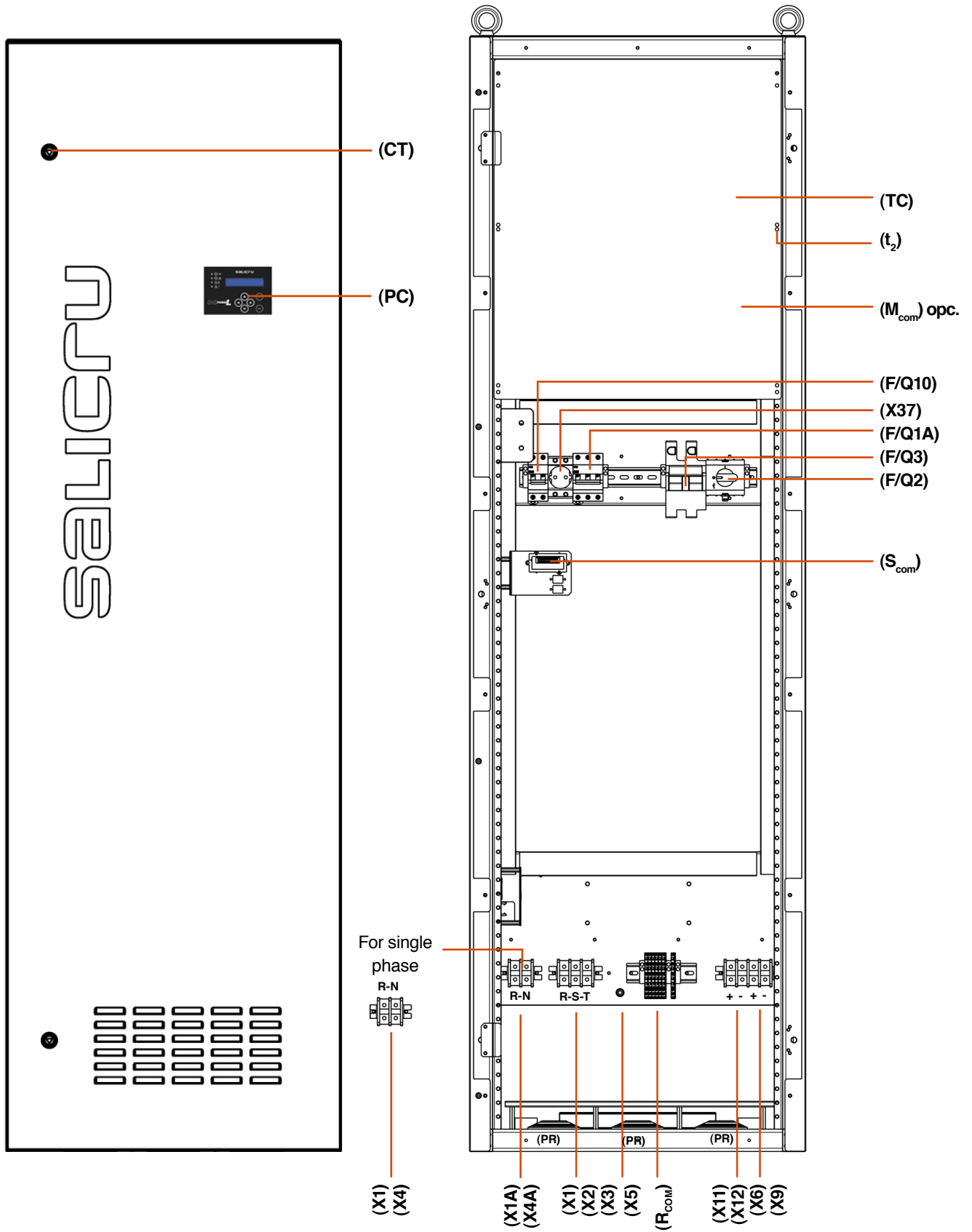

Fig. 2. Front view of rectifier cabinet with closed and opened front door (PF) measuring 650 x 615 x 2120 mm.

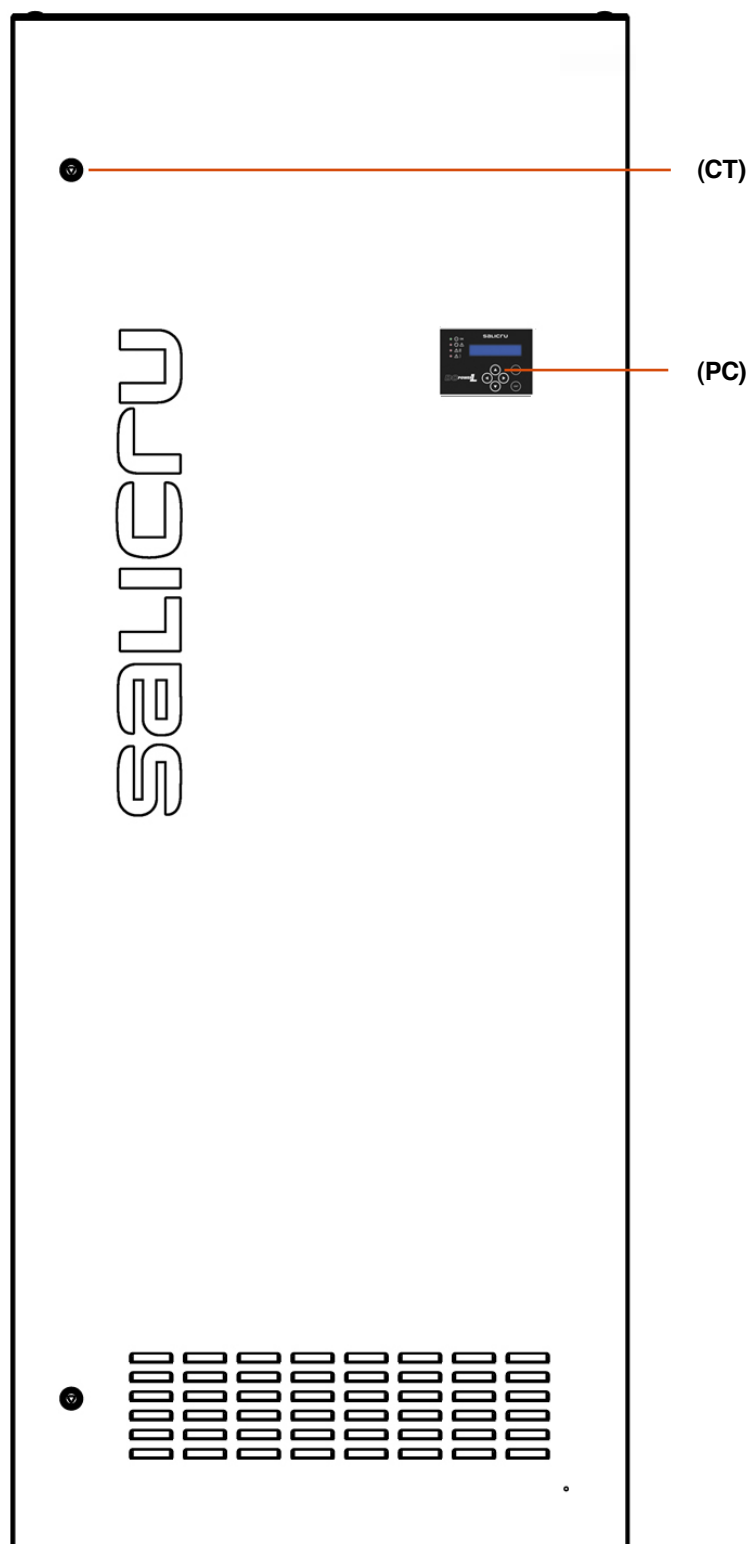

Fig. 3. Front view of rectifier cabinet with closed front door (PF) measuring (650 & 850) x 815 x 2120 mm.

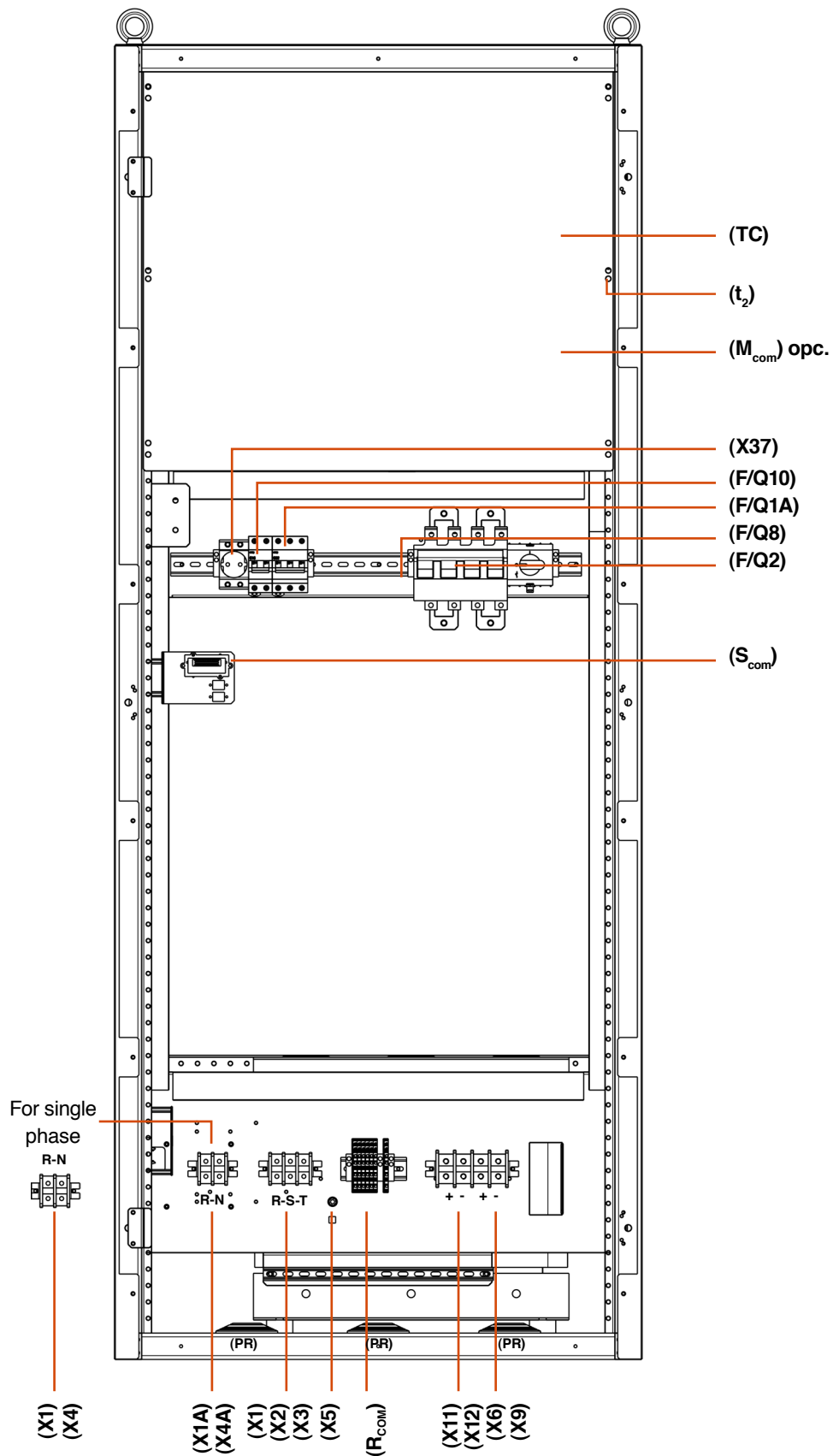

Fig. 4. Front view of rectifier with open front door (PF) measuring (650 & 850) x 815 x 2120 mm.

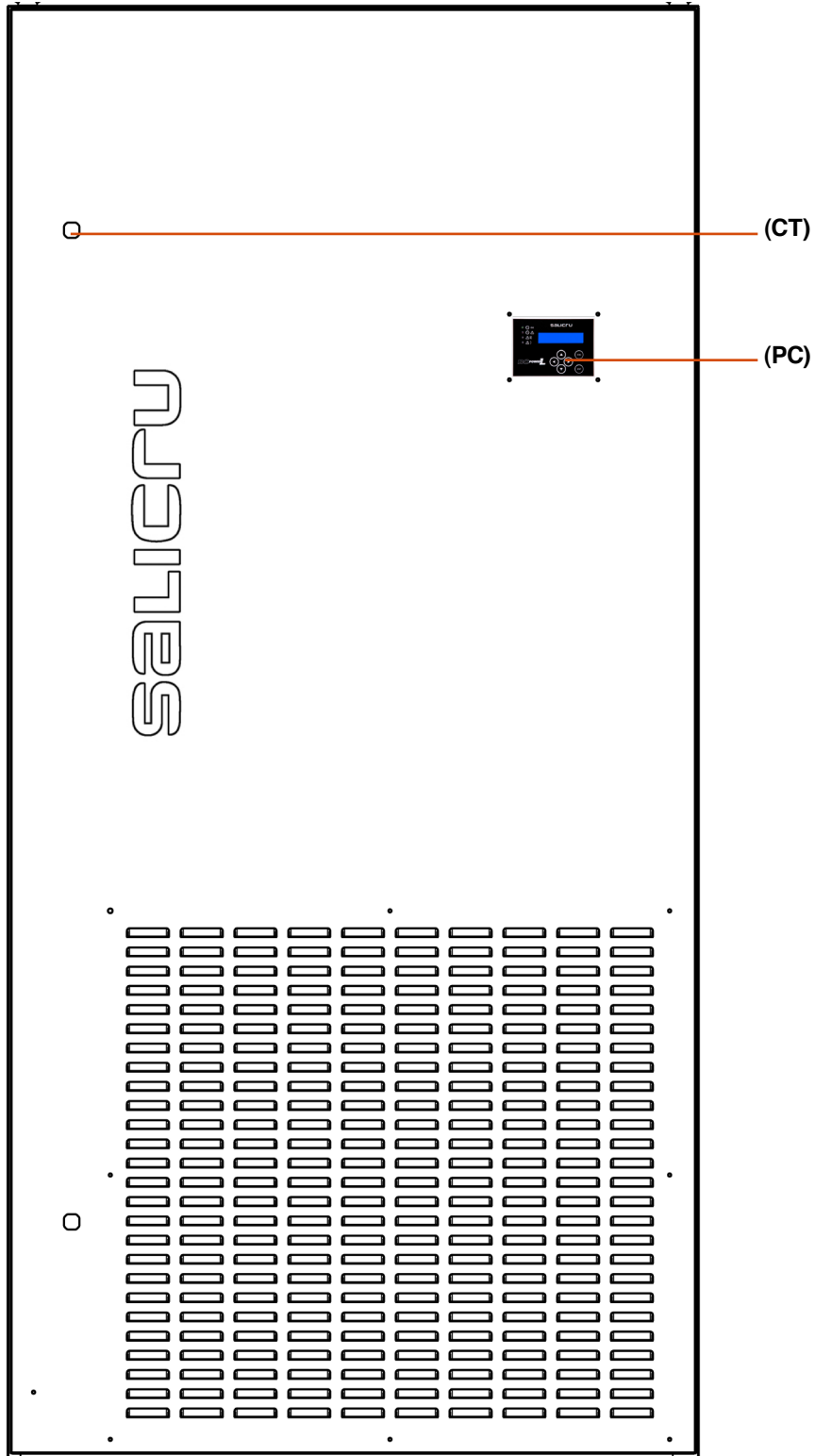

Fig. 5. Front view of rectifier cabinet with closed front door (PF) measuring 650 x 915 x 2120 mm.

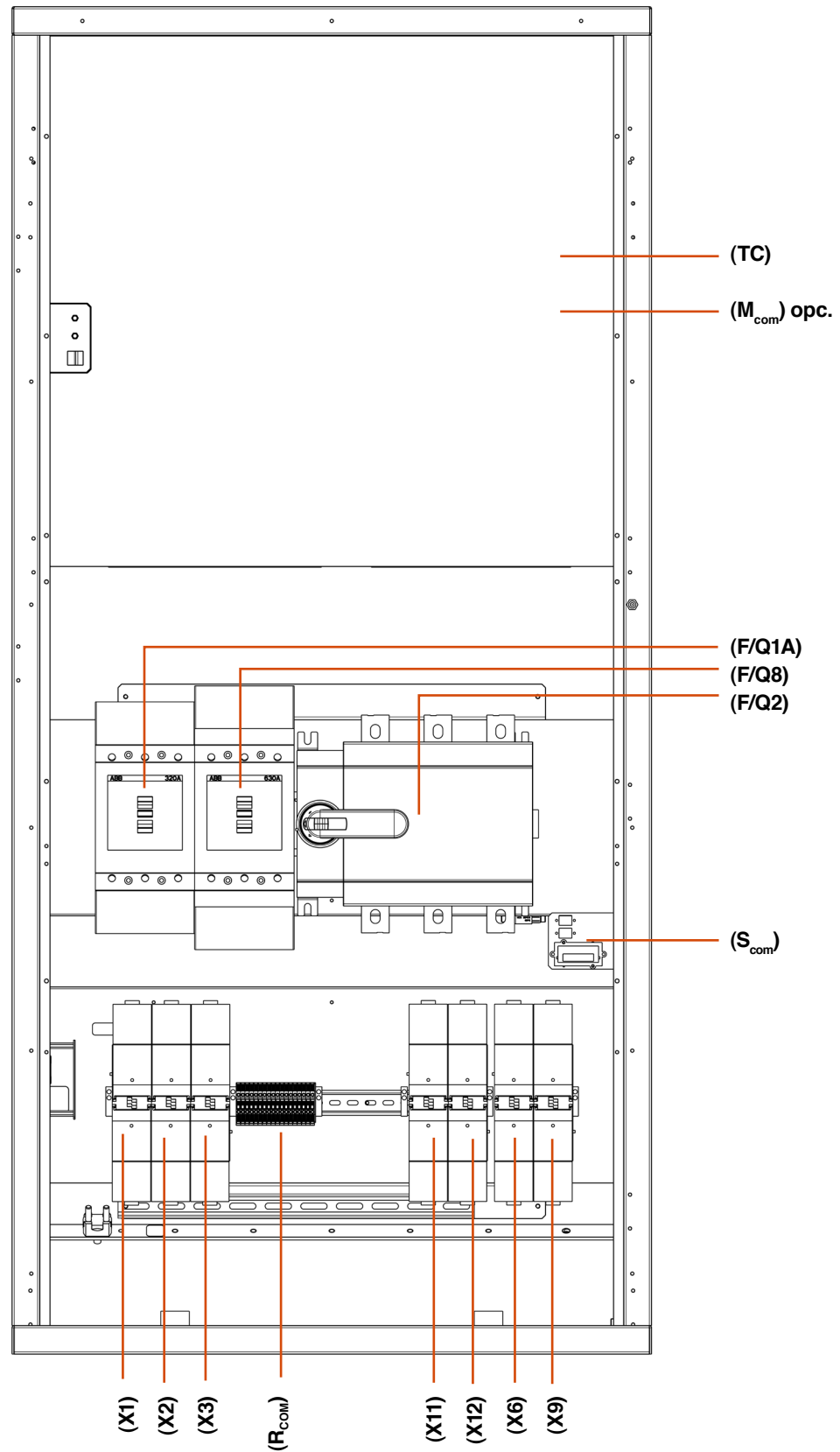

Fig. 6. Front view of rectifier cabinet with opened front door (PF) measuring 850 x 915 x 2120 mm.

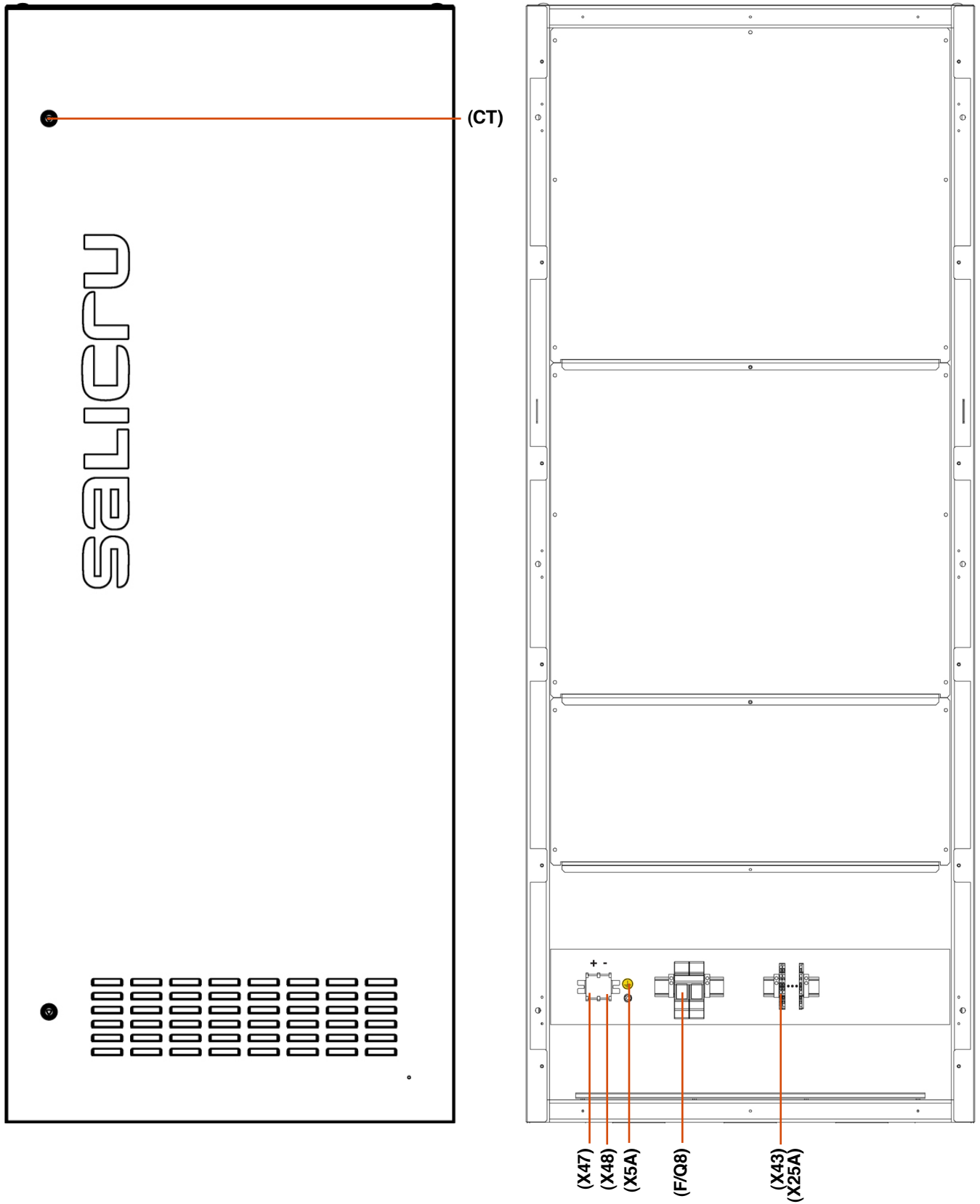

Fig. 7. Front view of battery cabinet with closed and opened front door (PF) measuring (650 & 850) x 815 x 2120 mm.

4.1.1. Dimensional drawings.

- Considerations to take into account:
 - ❑ The standard cabinet supplied is rack type with a base measuring 600x600 mm (see Fig. 8) or 600x800 mm, (see Fig. 9).
 - ❑ The dimensions of the rectifier and battery cabinets are the same and the only external difference is the control panel on the device.
 - ❑ The device can operate with PbCa or NiCd batteries, either sealed or with maintenance. Unless indicated otherwise, they should be PbCa sealed.

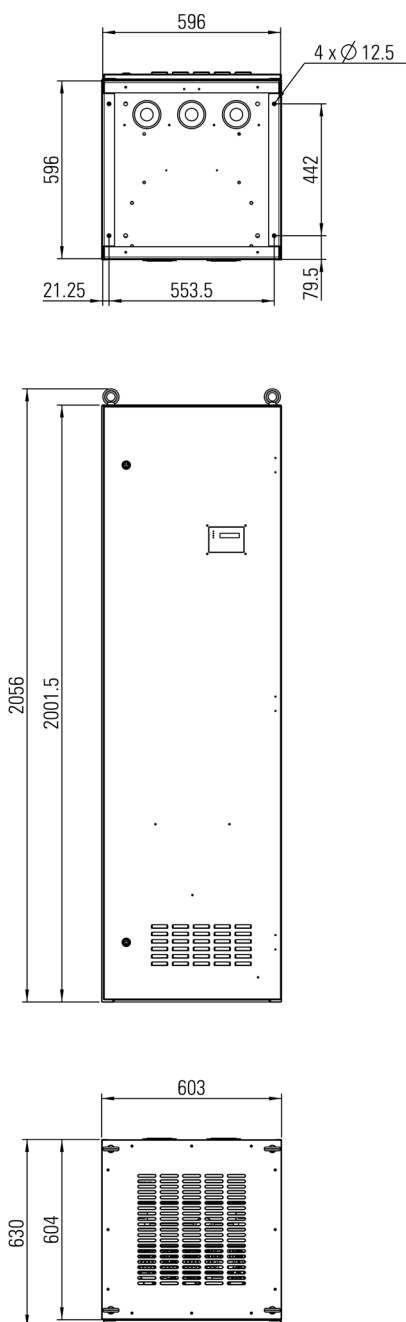

Fig. 8. Cabinet dimensions 650 x 615 x 2120 mm

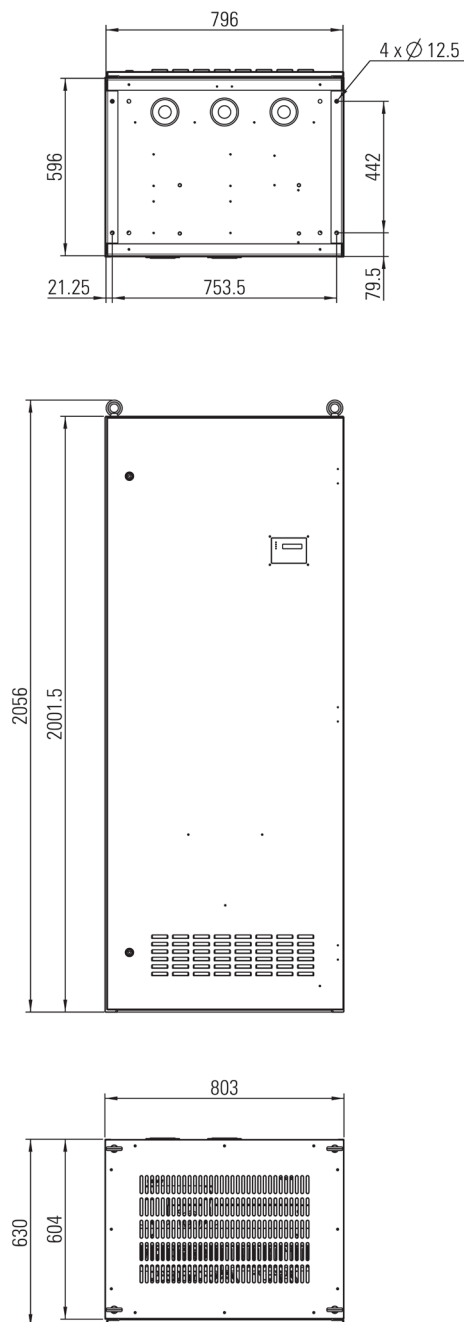

Fig. 9. Cabinet dimensions 650 x 815 x 2120 mm.

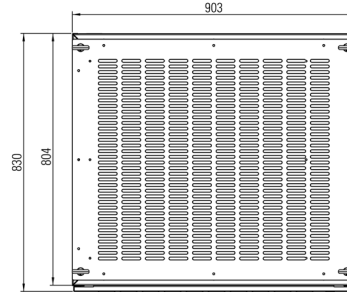
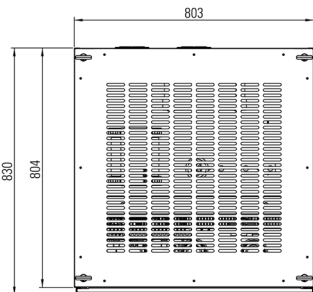
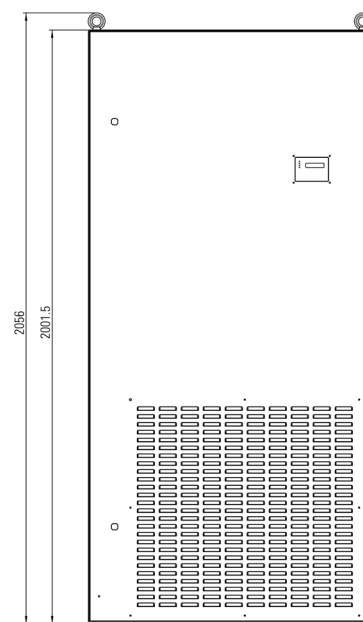
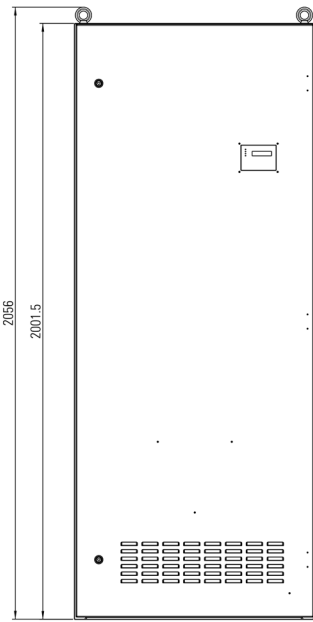
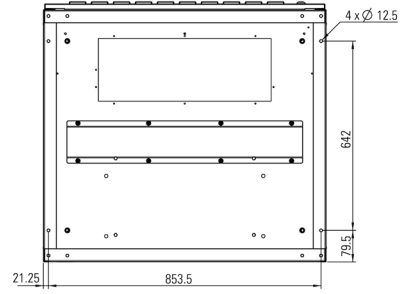
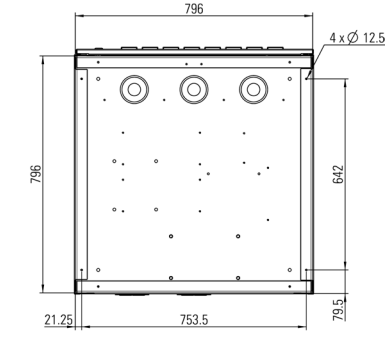



Fig. 10. Cabinet dimensions 850 x 815 x 2120 mm.

Fig. 11. Cabinet dimensions 850 x 915 x 2120 mm.

4.1.2. Device views key.

Connection elements.

- (X1) AC input terminal, R phase.
- (X2) AC input terminal, S phase. ⁽⁰⁾
- (X3) AC input terminal, T phase. ⁽⁰⁾
- (X4) AC input terminal, N neutral. ⁽¹⁾
- (X1A) AC input terminal, R phase. Auxiliary network for maintenance and supply service for (X37) (optional, only for Premium LP devices).
- (X4A) AC input terminal, N neutral. Auxiliary network for maintenance and supply service for (X37) (optional, only for Premium LP devices).
- (X5) Terminal or strip for earth connection (⊕) and earth bonding terminal (⊖) of the DC Power-L.
- (X5A) Terminal or strip for earth bonding terminal (⊖) of the battery cabinet. ⁽²⁾
- (X6) Positive (+) output terminal.
- (X9) Negative (-) output terminal.
- (X11) Positive (+) battery terminal in system cabinet. Only on devices where the batteries or part of them are installed outside the DC Power-L cabinet.
- (X12) Negative (-) battery terminal in system cabinet. Only on devices where the batteries or part of them are installed outside the DC Power-L cabinet.
- (X25A) Terminals for electrolyte level sensor in cabinet or battery rack (only on devices with optional sensor).
- (X37) Schuko socket for TSS maintenance work (optional).
 Only usable for maintenance work with open door and with an ambient temperature < 40 °C.
- (X43) Auxiliary terminals for connection to (X43A) of battery cabinet. ⁽²⁾
- (X43A) Auxiliary contact terminals, protection of batteries in accumulator cabinet (F/Q8), for connection to (X43) of rectifier cabinet. ^{(2) (4)}
- (X47) Positive (+) battery terminal in accumulator cabinet. ⁽²⁾
- (X48) Negative (-) battery terminal in accumulator cabinet. ⁽²⁾

Connection elements and instructions for communications module (M_{com}).

See user manual EN030*00.

Protection and operation elements.

- (F/Q1A) General two-pole or three-pole input circuit breaker according to type of mains. ⁽⁴⁾
- (F/Q2) General two-pole output switch. ^{(3) (4)}
- (F/Q3) Disconnecter fuse for battery protection of the two poles (+) and (-), located in the rectifier cabinet. ^{(3) (4)}
- (F/Q8) Disconnecter fuse for battery protection of the two poles (+) and (-), located in the accumulator cabinet. ^{(2) (3) (4)}

- (F/Q10) Two-pole circuit breaker for auxiliary input. Useful for the maintenance service (optional, only for Premium LP devices).

Optical indications on control panel and others.

- (a) Correct output indication. Colour green.
- (b) Input fault indication. Colour red.
- (c) Urgent alarm indication. Colour red.
- (d) Non-urgent alarm indication. Colour red.
- (e) LCD display.
- (f) 'ENT' key.
- (g) 'ESC' key.
- (h) Forward key '▶'.
- (i) Backward key '◀'.
- (j) Right key '▶'.
- (k) Left key '◀'.

Other elements, abbreviations and auxiliary parts.

- (A_{batt}) Battery cabinet.
- (A_{rect}) Rectifier system cabinet, generically to refer to the complete device, with or without batteries.
- (AB) Clip for fastening cables to bar (BF).
- (BB) Battery trays. Removable for refillable PbCa or NiCd accumulators.
- (BF) Bar for fixing the connection cables using clips.
- (BL) Mechanical locking using screws for removable battery tray.
- (BZ) Base to secure to solid surface. Only for cabinets with removable battery trays.
- (CM) Eyebolts to lift the cabinet (optional).
 The structure is not intended to lift the cabinet with the batteries installed.
- (CT) Lock with ratchet or cams with handle, for front door of cabinet. It can incorporate a locking system with key (LL).
- (LL) Key for locking/unlocking lock (CT).
- (M_{com}) Communications module.
- (MB) Hose for connecting the battery cabinet to the rectifier (only when the batteries are installed in a separate cabinet).
- (MD) Hose for connection between cabinets with the electrolyte detector, when the batteries are supplied in a separate cabinet (only when the optional one is included).

If the batteries are located in the same cabinet as the rectifier, the electrical connection hose comes pre-connected with the detector from the factory.
- (MS) Hose with temperature sensor (R103).
- (P_A) Anchor points for securing the base to a solid surface. Only in cabinets with removable battery trays.
- (PC) Control panel with LCD display.

(PF)	Front door of rectifier and/or battery cabinet.
(PI)	Lifting elements -feet- (optional).
(PR)	Wall bushings for cable routing.
(R103)	Temperature/battery float voltage sensor.
(RN)	Slot for connection cable routing.
(RV)	Ventilation grilles.
(t₁)	Screws for fixing the terminal cover (TB) .
(t₂)	Screw for fixing the protective cover (TC) .
(TB)	Terminal cover.
(TC)	Blind cover.
(R_{COM})	Terminal for relays
(M_{COM})	Communications slot.



The instructions in this document indicate the work to be carried out in relation to fixing the cabinet to a solid base (floor). These recommended actions become **obligatory** when the cabinet has removable battery trays.

The removable trays are intended for systems with open PbCa or NiCd batteries with the purpose of simplifying implicit maintenance tasks and more specifically for monitoring and checking the electrolyte level.

- ⁽⁰⁾ Terminals available only in three-phase devices.
- ⁽¹⁾ Terminal available only in single-phase devices.
- ⁽²⁾ **Connection or operation elements in the battery cabinet.** Only in systems with accumulators or part of them, in a cabinet or rack separate from the rectifier.
- ⁽³⁾ The output and battery protection or disconnecter will always be two-pole for floating output voltage. For outputs referenced with positive or negative earth, the protection or disconnecter will always be single-pole so as not to disconnect the pole connected to earth through the earth.
- ⁽⁴⁾ The protections or switches can optionally incorporate an auxiliary contact chamber as an alarm of type NC, NO or a switched contact.



With reference to the protections, this manual uses the abbreviations **(F/Q*)** to interchangeably refer to fuses **(F)** or circuit breaker switches **(Q)**, which, according to the regulations, are identified respectively with these abbreviations. The letter **(Q)** is also used to identify a simple disconnecter switch.

4.1.3. Nomenclature.

Rectifier.

2/DC-100-L 110-1/2x9AB147/213-3x220E COM EE553000

EE*	Rectifier with particular specifications.
COM	Potential-free contacts extended version.
E	Optional electrolyte level detection.
3x220	Rated input voltage. Disregard for 3x400V.
/213	Last three digits of the code of the type 2 battery.
147	Last three digits of the code of the type 1 battery.
AB	Letters of the battery family.
9	Number of batteries in a single branch.
2x	Number of branches in parallel of the type 2 battery. Disregard when there is only one battery branch of each type.
1/	Number of branches in parallel of the type 1 battery. Disregard for one branch and only one type of battery.
110	Rated floating output voltage.
-110	Rated output voltage with positive to earth.
+110	Rated output voltage with negative to earth.
L	Device series standard version (only single-phase devices with <5% ripple and no Schuko socket).
LP	Device series Premium version (with <1% ripple and Schuko socket).
100	Total output current to float voltage.
DC	Rectifier.
2	Number of rectifiers in parallel.

Battery cabinet

MOD BAT DC L 1/4x18AB147/073 25A EE553000

EE*	Battery module with particular specifications.
25A	Protection size.
/073	Last three digits of the code of the type 2 battery.
147	Last three digits of the code of the type 1 battery.
AB	Letters of the battery family.
18	Number of batteries in a single branch.
4x	Number of branches in parallel of the type 2 battery. Disregard when there is only one battery branch of each type.
1/	Number of branches in parallel of the type 1 battery. Disregard for 1 and only one type of battery.
L	Device series.
DC	Rectifier

5. Rectifier block diagram and description.

5.1. Block diagram.

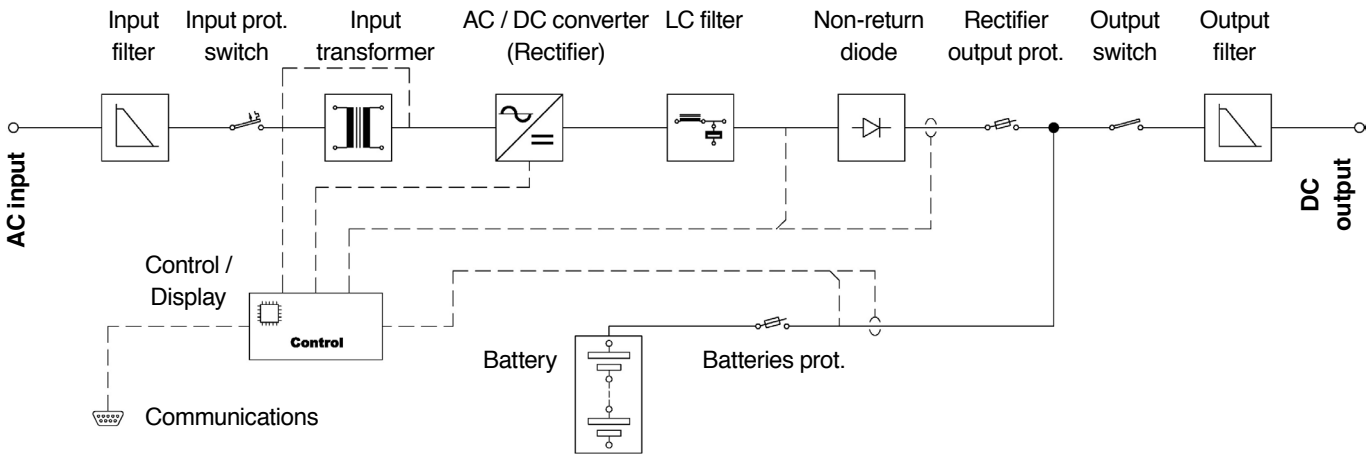

Fig. 12. Block diagram.

5.2. Description.

The DC Power-L family of rectifiers has been designed to offer a variety of fully configurable output voltages ranging from 24 Vdc to 220 Vdc and currents up to 800 A.

The DC Power-L is a low-frequency full-wave thyristor-controlled rectifier that converts AC input voltage into stabilised DC voltage. The DC Power-L rectifier cabinet is built with all of the necessary elements around the central core of the system.

5.2.1. General.

As thyristor-controlled rectification is a technology of great robustness and reliability, we have opted for a system with natural cooling, thus reducing the need to replace components prone to ageing such as fans and creating a system with superior reliability.

The main function of the system is to supply the output load and, at the same time, keep the system's backup battery charged and in optimum condition so that it can supply power to the load in the event of input mains failure or output overloads.

5.2.2. AC input.

For greater versatility, the system can be either single-phase or three-phase.

Regardless of the topology of the mains, protection elements are installed against voltage peaks that could come from the mains.

5.2.3. Input filter.

The system includes all necessary filters to ensure compliance with the electromagnetic compatibility standards required for CE marking. Being a thyristor-controlled rectification system that generates high input mains distortion, it is possible to have a device-integrated harmonic filter at the input to reduce reinjection to levels below 10%.

5.2.4. Transformer.

The system is equipped with a low-frequency input transformer through which an isolated voltage is obtained. This voltage is chosen according to the desired output voltage and is the one that is rectified by the thyristors to obtain the stabilised direct voltage.

5.2.5. Bridge rectifier.

Formed by six thyristors in full-wave three-phase bridge structure in six-pulse devices.

In single-phase devices the bridge consists of four elements. It is a highly robust low-frequency rectification structure and the part responsible for rectifying the output voltage to the desired value. It is equipped with RC networks for protection against transients and a temperature monitoring system for alarm and shutdown of the system as self-protection for the device.

5.2.6. Battery.

The device will function as a stand-alone power source even when the AC input mains fail, supplying voltage to the load connected to the output of the device by means of its backup battery.

To keep the battery in an optimum state and ensure a maximum life, the system monitors the current and voltage of the battery at all times, as well as the temperature of the battery room in order to enable the appropriate compensations to be made.

The system can charge all kinds of PbCa or NiCd batteries, either sealed or with maintenance. Batteries with maintenance can optionally include in their cells an electrolyte level detector to provide low level alarms.

The rectifier cabinet has battery fuses at both poles, which, in addition to providing the respective protection, facilitate connection in systems with battery banks external to the device.

5.2.7. Output filter.

For output ripple reduction, an LC filter is incorporated to keep the ripple voltage and current levels within the established limits and ensure correct operation of the output loads and the expected life of the battery.

The system also includes all necessary filters to ensure compliance with the electromagnetic compatibility standards required for CE marking.

5.2.8. DC output.

The isolation offered by the transformer allows a floating output with respect to the input, which enables earthing of either of the two output terminals (poles).

5.2.9. Control/Display.

The vital constants of the source are controlled digitally through a microprocessor which is also responsible for managing the settings and measurements shown on the LCD display.

All rectifiers are identical in operation regardless of the format, power and input/output voltage.

5.2.9.1. Control.

In normal operating mode, a PID is responsible for regulating the desired output voltage.

By means of an automatic priority change system (override control), the control is transferred to another current PID when one of the current limits is exceeded: batteries or rectifier.

A selective control enables automatic switching between the two currents to ensure that neither of the two limits is ever exceeded.

5.2.10. Relay Interface.

All systems incorporate as standard a relay interface with three relays, a battery temperature sensor for measuring and compensating the float voltage in relation to it and an Ethernet/SNMP adapter slot, plus three additional relays, an electrolyte level detection input for NiCd batteries and ports RS-232 and RS-485 in their extended COM version.

Relay n°.	Description of relay programming
1	Reserved
2	Groups the following alarms: - Input failure - RS and/or ST and/or TR input undervoltage
3	Groups the following alarms: - Rectifier overload - Battery overtemperature - Battery current high - Heat sink overtemperature - Battery voltage low - Battery overvoltage - RS and/or ST and/or TR input overvoltage - Output voltage low - Output voltage high - Electrolyte level low
4	Groups the following alarms: - Isolation failure + ⁽²⁾ - Isolation failure – ⁽²⁾
5	Reserved

Table 2. Description of standard relay programming

Other configurations are available on request, but always in the factory or later by TSS, and associating any of the system alarms with one of the relays interchangeably and even associating more than one alarm with the same relay.

5.2.10.1. Electronic unit for NIMBUS remote maintenance (optional).

The NIMBUS electronic remote management unit enables real time monitoring, analysis and technical support 24 hours a day, 7 days a week, by members of our staff, thus reducing the mean time to repair (MTTR) in the event of any unexpected situation.

During monitoring, an events and alarms history is created to enable a thorough analysis of the device, providing valuable information on operating tendencies and thus identifying potential future problems. In addition, a detailed device status report is sent to the customer every month.

5.2.11. Protection.

The device's own control includes a current limitation system that ensures that all components work in the correct mode, thus guaranteeing the expected life of the system.

With the input circuit breaker protection, protection against transformer overload is guaranteed, preventing overheating and premature ageing leading to system failures. In addition, the use of an input circuit breaker enables the user to reset the system, avoiding technical service interventions for fuse changes that would involve an unacceptable shutdown period for the application.

The semiconductor temperature control and overtemperature shutdown system provides added protection by reducing the need for device interventions in the event of abnormal operation, since it protects the most important part of the system, preventing

failure and saving on possible expensive repairs.

For the protection of personnel, it also has isolation failure detection, which provides an alarm if a potentially dangerous situation arises.

In addition to the protection of batteries by means of fuses indicated above, there is an output fuse in the rectifier assembly where it joins the accumulator bank and load output.

5.3. Management of batteries and charging levels.

The charger is fully automatic, capable of operating autonomously.

It is designed in such a way that the different output voltage levels according to the current/voltage characteristic are stabilised at 1% of their rated value for an operating range of 0% to 100% of the rated load in the event of input wave voltage and frequency variations.

The charger's output voltage ripple factor does not exceed 1% defined as the ratio between the peak-to-peak value and the RMS value of the wave, with the battery connected to its output or 3% without it for an operating range of 0 to 100% of the rated load in the event of input wave voltage and frequency variations.

The output current of each charger is equal to the current demanded by 100% of the loads plus the maximum charging current of the battery according to the current/voltage characteristic corresponding to quick charging, so that the battery can recover 100% of the capacity transferred during the specified discharge cycle in a maximum period of 12 hours, with the charger simultaneously powering 100% of the loads.

5.3.1. Charging levels.

The device is designed to work at three charging levels and therefore at three voltage levels:

5.3.1.1. Floating

The charger maintains its corresponding stabilised voltage by means of which it powers the assigned loads and supplies the current for preserving the battery charge according to the current/voltage characteristic.

Under normal conditions, the charger will be in float mode, supplying the battery with a maintenance current, the small current that is provided to the battery to keep it charged and prevent self-discharge.

When a mains failure occurs, the battery will discharge according to the requested consumption.

5.3.1.2. Quick charge.

In this position, the charger provides the permanent load and battery charging according to the current/voltage characteristic, keeping its voltage stabilised. When mains power returns, the rectifier will automatically switch to quick charging mode, supplying the current requested plus a limited and constant current (equal to the capacity, in Ah/5) for restoring the charge of the battery. Once the maximum operating voltage level has been reached, the battery will gradually absorb less current.

Once the battery recharges, the device will automatically go to float mode.

The duration of the quick charge will be proportional to the discharged Ah.

This kind of charging can be started automatically or manually via the control panel.

5.3.1.3. Exceptional charging.

In this position, the charger will switch to exceptional manual charging of the battery, which has the purpose of homogenising and regenerating the active substances in the battery electrolyte.

Exceptional charging will only be carried out by manual forcing via the control panel and with the device out of service if it is considered harmful for the loads connected to the rectifier output.

The timing of the charging process (24 h) must be set at the start, so that it will end automatically. Once exceptional charging is finished, the charger will switch automatically to float mode.

In the event of manual interruption of exceptional charging, the charger will automatically switch to quick charging mode until the batteries are fully charged and then float charging.

5.3.2. Charging type priorities.

Table 3 below shows the established charging type priorities:

Type	Priority	Comment
Floating	Low	Less priority than quick and exceptional charging
Quick charging	Medium	Less priority than exceptional charging
Exceptional charging	High	Maximum priority

Tabla 3. *Charging type priorities*

5.3.2.1. Activation and deactivation of charging types.

Quick charge.

	Automatic	Manual	Periodic
Activation	AC failure and battery charge lower than 100%	Via control panel	Yes*
Deactivation	AC OK and battery charge at 100% or AC OK and charging time greater than the time determined as maximum quick charging	Via control panel	AC OK and battery charge at 100% and charging time greater than the minimum quick charging time or AC OK and charging time greater than the time determined as maximum quick charging
Considerations	*Each automatic deactivation automatically recalculates the next periodic trip		

Table 4. *Activation and deactivation of quick charging.*

Exceptional charging.

	Automatic	Manual	Periodic
Activation	No	Via control panel and open output switch ⁽⁵⁾	No
Deactivation	Charging time exceeds maximum set	Via control panel	No

⁽⁵⁾ The output switch must have an auxiliary contact block (optional), so that it can inform the control panel of the switch's opening operation (Off).

Table 5. *Activation and deactivation of exceptional charging.*

Considerations

The battery is considered to be charged when there is a lack of mains voltage and it is capable of giving a complete cycle and, at the end of it, the operating voltage is not lower than the minimum admissible voltage.

To avoid premature ageing of the battery due to long periods of float charging without discharging, quick charging can be activated manually via the control panel (with timed stopping) and periodically (with timed activation) to restore the full charge of the battery.

6. Device reception.

6.1. Reception and unpacking.

- On reception of the device, check that it has not been damaged during transportation. If it has been damaged, notify your supplier or, in their absence, our company. Also check that the information on the label affixed to the packaging matches that specified on the order. If it does not, report the issue as soon as possible, quoting the device's manufacturing number and any delivery note references.
- After reception, if it is not put into service immediately, it is advisable to keep the device in its original packaging to protect it from impacts, dust, dirt, etc.
- The packaging of the device consists of a wooden pallet (if requested in the order), cardboard box, expanded polystyrene (EPS) corners, polyethylene cover and polyester strapping. All of these materials are recyclable, so any disposal must be carried out in accordance with current laws. We recommend keeping the packaging for possible future use.

- To unpack the device, follow the steps in Figure 11.
 - ❑ Cut all of the polyester straps '1' and remove the corners '2'.
 - ❑ Remove the lid '3'.
 - ❑ Remove the four corners '4'.
 - ❑ Remove the cardboard box '5'. To do so, lift it upwards and remove it completely.
 - ❑ The device will be standing on the pallet wrapped in its plastic cover '6'. Remove it by pulling it from above.

In general, cabinet systems are supplied without a pallet, unless expressly requested in the order, since the base is designed, among other functions, to enable the entry of a pallet jack or forklift and facilitate transportation to the site.

For devices ordered with a pallet and/or eyebolts, both only on request, proceed as follows:

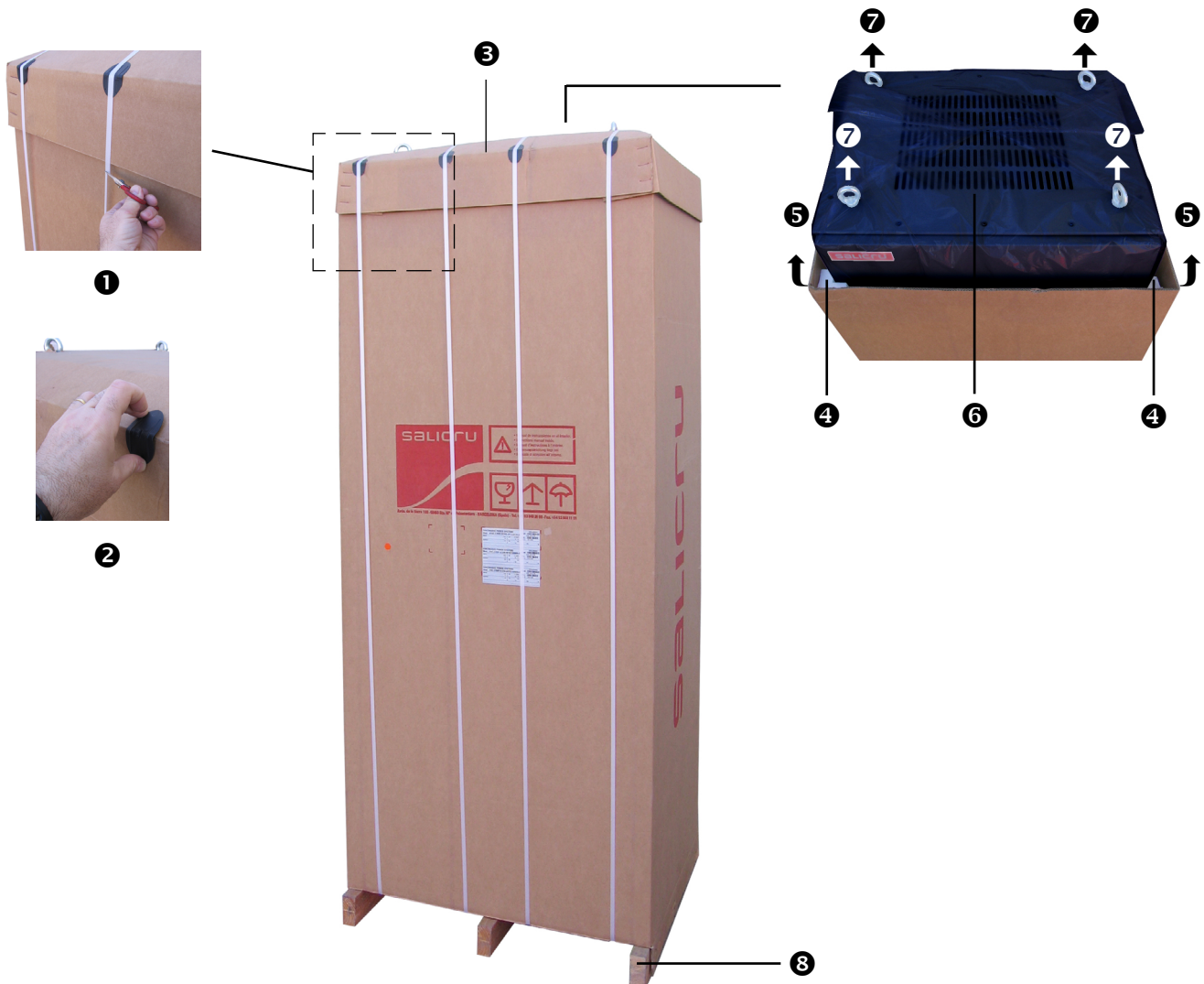

Fig. 13. Unpacking process.

❑ Lift the device using the eyebolts 'Ø' (CM) with the mechanical means available, taking into account the weight of the model indicated in the table below and without the batteries, since these are not supplied pre-installed inside the system.

❑ Remove the wooden pallet (Ⓢ).

❑ Before device and/or cabinet or battery cabinet installation in the final location, check that the floor is adequate to support the weight.

If as a result of special backups or other specifications, the weight of the battery cabinet is not shown in the table, use as a reference the weight indicated on the packaging's **packing list**.

For batteries supplied on more than one pallet, add up all of their weights.

❑ For systems with rechargeable PbCa or NiCd accumulators in which the battery trays are removable, fix it to the floor using the holes located in the base (BZ) before installing the batteries.

⁽⁶⁾ The dimensions and weights indicated in this table are for standard backups. Consider as additional information that the weight of the battery bank is indicated on the packing list, regardless of whether they correspond to a model with standard or special backup.

• Together with the rectifier documentation, 4 trim screws are supplied to replace the eyebolts (CM) in the cabinet systems (only if optional eyebolts were ordered). Once the device is installed or secured to the base or floor, they can be replaced.

6.2. Packing list and contents.

• The number of cabinets varies depending on the device model, with each one of them having an individual package.

In addition, it is necessary to consider that the batteries are supplied packed on one or more pallets, depending on their weights.

Check that the number of packages matches those indicated in the packing list documentation.

6.3. Storage.

• The device should be stored in a dry, ventilated room and protected from rain, dust, and water or chemical splashes. It is advisable to keep devices and batteries in their original packaging, as it has been specifically designed to ensure maximum protection during transportation and storage.

•  The batteries are supplied packed on one or more pallets depending on the model, separated from the DC Power-L cabinet and/or battery cabinet itself.

Always take note of the diagram provided regarding everything related to the polarity, position, orientation and connection of each battery and between batteries, as well as between the accumulator bank and the system itself when they share a cabinet.

• Regardless of the type of accumulators used in a device, the **design life** of the batteries is regulated by the official European body EUROBAT, taking into account, among other characteristics or conditions, temperature, float voltage, number of charging and discharging cycles, depth of discharge, etc.

Because temperature is a very influential factor in the life expectancy of batteries, this body recommends that a storage and operation temperature of 20°C should not be exceeded as far as possible, since the degradation will be significantly higher.

• Before using a device with batteries in which the backup is determined by accumulators, for the first time or after a long period of time without use (maximum 6 months), it is necessary to connect it to the power supply and leave the batteries charging for at least 12 hours.

Although the unit can operate without charging them, consider the risk of a prolonged power cut during the first hours of operation and the backup time or backup available for the device's batteries, which can be reduced.

7. Installation.

- Supplied with this user manual and included in the same documentation Pendrive is the EK266*08 'Safety instructions' document.

Before carrying out any action on the device relating to its installation or startup, change of location, configuration or handling of any kind, carefully read the safety instructions.

⚠ Compliance with the 'Safety Instructions' is obligatory, with the user being legally responsible for observing and applying them. Read it carefully and follow the steps indicated in the order established.

- Before installing or commissioning the system, check that all of the information related to the device is available and close at hand, otherwise request it.

The user manual and all related information is a guide that should be kept for reference in case of future queries.

- ⚠** If you do not **fully understand the instructions, especially those concerning safety, you should not continue** with installation or startup tasks, as this would represent **a risk to your safety and that of others, resulting in possible serious injury or even death**, in addition to **damage to the device and/or loads and installation**.

- ⚠** Local electrical regulations and different restrictions in the customer's location may invalidate some recommendations contained in the manuals. Where discrepancies exist, the relevant local regulations must be complied with.

- Check that the information on the nameplate affixed to the inside of the device's front door is that required for installation.

- The system is supplied in a completely closed cabinet, with a front door (PF) equipped with two locks with ratchet (CT) of the type with 8 mm triangular key (LL). Other lock models can also be supplied, such as key lock (LL) with doorknob for quick opening, slot for flat screwdriver or retractable handle with a ratchet lock or cams with or without key lock (LL).

Fixed to the front door (PF) is the control panel (PC), visible and accessible from outside as an interface with the user. To perform any installation, startup or maintenance operation, open it by unlocking the two locks (CT).

- ⚡** Finally, it is obligatory to leave the cover or covers of the cabinet(s) in position and the front door closed after any connection and/or startup operations.

- ⚠** The surface on which the system is to be installed must be properly prepared to support its weight and level to prevent the metal structure from having to withstand unnecessary and harmful mechanical torsion.

Any warping or buckling can represent a serious problem and hazard depending on the degree, especially for rectifier cabinets with batteries installed inside or accumulator cabinets themselves, since the greater the weight that the structure has to withstand, the more it will suffer.

Any inclination of the cabinet with respect to the floor and/or between the covers and ceiling can be seen optically, this being the lesser evil in comparison to damage caused to the structure.

- It is necessary to fix the cabinet or cabinets to a solid and secure surface (floor), when the battery trays are removable:

⚠ It has been found that there is a risk of overturning the cabinet when removing drawers containing batteries, with potential serious injury to the operator. **Consequently, it is imperative to affix clearly visible signs to warn of the need to firmly secure the cabinet to the floor with elements that ensure total and permanent sturdiness, and to do so before starting the process of installing the batteries.**

Proceed as follows:

- Carry out the necessary work to ensure a solid and level surface, with fixing points consisting of M12 threaded studs with a thread length of approx. 3 cm.

Fig. 12 shows the machining of the base of the cabinets of 600x800 and 800x800 mm, seen from below.

- Place the device and/or battery cabinet on the floor or machined surface.

- Fix base (BZ) of the cabinet to the floor, through the anchor points (P_A) provided of \varnothing 12.5 mm, using M12 nuts and washers.

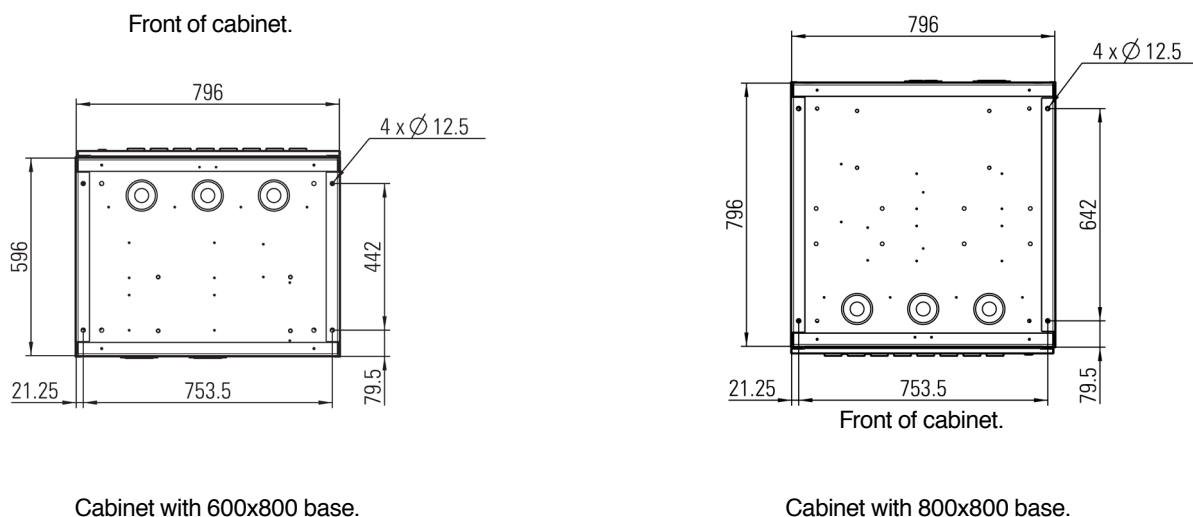



Fig. 14. Machined base of the cabinets.

- Repeat the task for each cabinet if there are more than one unit.

-  Even if the actions indicated in the previous point have been carried out correctly, **never remove more than one tray with batteries, as there is a high risk of mechanical torsion of the frame itself.**



7.1. Look after your safety.

- All electrical connections and disconnections of device cables, including control cables, must be carried out without the presence of mains power and with the switches and protections always in standby, position 'O' or 'Off'.
- Before physically installing the accumulators, check that the protections or disconnectors of the system are in the 'Off' position, especially that of the batteries of the device (**F/Q3**) and its counterpart (**F/Q8**) in the battery cabinet, when there is an external accumulator bank.

When the protection consists of fuses, these are supplied already inserted into the fuse holder base, as the batteries themselves are not delivered already installed in the cabinet. This way, any loss or mislaying is avoided.

- The batteries are always supplied in packaging separate to the device cabinet or accumulator cabinet or cabinets. Consequently, it will be necessary to install and connect them according to the connection diagram supplied with the documentation, using the accessories provided, such as strips, cables and screws.

Start the process by placing the batteries in the lower tray to secure the cabinet, ensuring that the centre of gravity is as low as possible, and work your way up as the trays are filled.

- In systems with removable trays, it is advisable to insert them as they fill up, thus avoiding unnecessary mechanical stresses on the frame itself, which can lead to structural torsion.
 - To remove each battery tray (**BB**), it is necessary to remove the two screws (**BL**) that fix it like a mechanical lock located on either side of the front.
 -  Wait until the end to connect the end cables between levels, otherwise there is a risk of electric shock.
 - Fill up the trays with the accumulators one by one, interconnect the batteries between them and insert each tray as individual tasks are completed on each of them. Fit the two screws (**BL**) which act as a lock and tighten them.
 - Then connect the batteries between levels, observing the safety instructions indicated in this document and in EK266*08.
-  Precautions must be taken with the batteries once interconnected, as there may be dangerous voltage between the terminals of different batteries or between one of them and the earth, depending on the total voltage of the bank.
- In systems with 0/ or 0A backup, the acquisition, installation and connection of batteries will always be carried out **under the responsibility** of the customer. Information concerning the batteries in terms of number, capacity and voltage is indicated on the battery label affixed next to the device's nameplate. **Strictly observe** this information, the connection polarity of the batteries and the connection diagram supplied with the documentation and the DC Power-L.
-  Any handling and connection of the batteries should only be carried out or supervised by **suitably quali-**

fied personnel.

Before carrying out any action, disconnect the batteries. Check that no current is present and that there is no dangerous voltage at the ends of the terminals of the battery bank.

The battery circuit is isolated from the input voltage of devices with floating output voltage, but not from devices with output voltage referenced to earth. Dangerous voltages can occur between the terminals of the battery bank and the earth.



Check that the system does not have input voltage before working on the batteries, otherwise the rectifier will supply DC voltage to the cables connected to the accumulator bank, with the resultant risk.

-  It should never be forgotten that the DC Power-L with batteries is a generator of electrical power, regardless of whether the batteries are installed in the same cabinet or in the device itself, so the user must take all necessary precautions against direct or indirect contact.

If the batteries are connected to the device and its protections are set to 'On,' it is irrelevant whether or not the DC Power-L is connected to the power supply, as is the state or position (On or Off) of its protection.

The output terminals will supply voltage while the battery bank has power, unless the output disconnector switch (**F/Q2**) is 'Off' or, if there is output distribution, the general protection of the output distribution or each of the individual output distribution protections is set to 'Off.'

7.2. Considerations to take into account.

- The location should be spacious, airy and easily accessible. The slots of the ventilation should never be obstructed, nor should the device be installed outdoors.
-  To allow personnel to operate comfortably, it is recommended to leave a free space of 1 m in the front part that allows the rack cabinet door to be opened freely and facilitates the operation of the different parts and elements of the equipment.
-  It is also necessary to leave a minimum of 30 cm. at the back of the cabinet to allow free circulation of ventilation air pushed by the fans.
- The cross sections of the input, output and earth cables must be in accordance with the rated current indicated on the nameplate, and compliance with the country's regulations and legislation is an essential requirement.
- A bad connection or operation can cause faults in the device and/or the loads connected to it. Read the instructions in this manual carefully and follow the steps indicated in the order established.
- The base of the cabinet features a number of wall bushings (**PR**), to isolate the routing of the connection cables through the metal sheet of the cabinet. Cut them to the appropriate section to enable the respective input, output and battery cables to pass through them in models with the accumulators in a separate cabinet. Upon request, some cabinets can have a slot (**RN**) to serve as a conduit for cable entry, instead of the wall bushings (**PR**).
- All of the cables will be fixed by clips (**AB**) to the bar (**BF**), in order to immobilise them and prevent possible pulling that could lead to false contacts, cable disconnection, etc., and consequently, to failures of the device and/or possible accidents due to electric shock.

7.3. Earth connection, terminal or strip (X5) and/or (X5A).

- It is advisable, **and so required by** the regulations or legislation of the country, to **connect the device to earth**.

Make sure that all of the device's loads are only connected to earth in the form of a terminal or strip (**X5**). Failure to limit the earthing of the loads to this **single point** would create earth return loops and degrade the quality of the power supplied.

All terminals identified as an earth connection (⊕) are linked together and to the earth of the cabinet.

- For models with batteries in a separate cabinet, connect the terminal or strip (**X5**) of the earth of the rectifier to terminal (**X5A**) of the earth connection (⊕) of the accumulator cabinet, using the cable provided in the battery connections hose.
- The DC Power-L can be supplied from the factory with connection of positive to earth, negative to earth or float. On the nameplate and terminal labelling, the type of connection is identified by means of symbols '+' or '-' placed before the value of the output voltage and the symbol for live pole is indicated.

It is **very important** to ensure that the loads to be connected to the device have the same type of connection as this one, otherwise it would pose a risk to personnel and destroy the system and associated devices.

By default and if not indicated otherwise, all devices have floating output voltage.

-  It is recommended to use shielded cables for communications, as well as the earth connection of the screen through the terminal or strip (**X5**).

7.4. Connection of the system to the cabinet or battery bank. Terminals (X11) - (X12) and (X47) - (X48).

- This operation is only intended for the connection between the battery terminals of a system and the respective ones of the cabinet or cabinets, or battery bank, regardless of whether the batteries are owned by the customer or supplied with the device.

All of the instructions concerning the physical installation of each of the elements inside the system or battery cabinet are described in Section 7.1.

- All of the protections or disconnectors of the system must be in the 'Off' position and, in particular, that of the batteries of the device (**F/Q3**) and its counterpart (**F/Q8**) in the accumulator cabinet, when it has an external battery bank.

 Since the fuses of the disconnectors are supplied already installed to prevent them from being lost or mislaid, it is important to check that the disconnectors are open (Off).

- Connect the cable hose, usually supplied, between terminals (**X11**) - (**X12**) of the system and (**X47**) - (**X48**) of the battery cabinet or bank, respecting the colour of the cables (red for (+), black for (-) and green-yellow for the earth connection (⊕)) as well as the polarity indicated on the label of the device (see Fig. 13).

-  In systems with more than one battery cabinet/bank, the connection in parallel between them and the system will be taken into account according to each particular case. The battery connection diagram supplied with the documentation will always take precedence.

Battery terminals in rectifier cabinet.

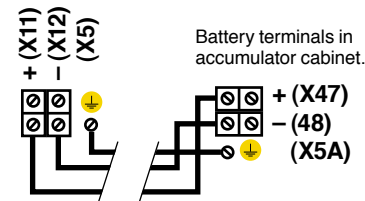





Fig. 15. Connection of the system to a battery cabinet.

-  Do not start the system without having previously connected the batteries to the device.

7.5. Connection to the main AC power supply network. Terminals (X1) and (X4) or (X1), (X2) and (X3) for single or three-phase.

- All of the protections or disconnectors of the system must be in the 'Off' position and, in particular, that of the batteries of the device (**F/Q3**) and its counterpart (**F/Q8**) in the accumulator cabinet, when it has an external battery bank.

 Since the fuses of the disconnectors are supplied already installed to prevent them from being lost or mislaid, it is important to check that the disconnectors are open (Off).

-  The earth connection (⊕) of the device must be connected to the terminal or strip (**X5**), making sure that this is done before connecting the voltage to the input of the device.
- Connect the power supply cables to terminals (**X1**) and (**X4**) for single-phase devices or (**X1**), (**X2**) and (**X3**) for three-phase systems, respecting the order of the phase or phases and the neutral indicated on the labelling of the DC Power-L.
-  If the phase order is not respected, the three-phase device will not work.

7.6. Connection to the auxiliary AC power supply network. Terminals (X1A) and (X4A).

- All of the protections or disconnectors of the system must be in the 'Off' position and, in particular, that of the batteries of the device (**F/Q3**) and its counterpart (**F/Q8**) in the accumulator cabinet, when it has an external battery bank.

 Since the fuses of the disconnectors are supplied already installed to prevent them from being lost or mislaid, it is important to check that the disconnectors are open (Off).

-  The earth connection (⊕) of the device must be connected to the terminal or strip (**X5**), making sure that this is done before connecting the voltage to the input of the device.
- There are two terminals (**X1A**) and (**X4A**) exclusively for supplying power to the Schuko socket (**X37**), whose use is re-

served for the maintenance and/or repair services of our **TSS** and which is protected by the circuit breaker switch (**Q10**).

Connect the auxiliary AC power cables to terminals (**X1A**) and (**X4A**) respecting the order of the phase and the neutral indicated on the labelling.

7.7. Connection of the loads to DC output terminals (**X6**) and (**X9**).

-  The earth connection (⚡) of the device must be connected to the terminal or strip (**X5**), making sure that this is done before connecting the voltage to the input of the device.
- The DC Power-L can be supplied from the factory with positive or negative connection referenced to earth, or float. On the nameplate and terminal labelling, the type of connection is identified by means of symbols '+' or '-' placed before the value of the output voltage and the symbol for live pole is indicated.

 **By default and if not indicated otherwise, all devices are dispatched from the factory with floating output voltage.**

-  It is **very important** to ensure that the loads to be connected to the device have the same type of connection as this one, otherwise it would pose a risk to personnel and destroy the system and associated devices.
- The type of output protection is predetermined and established as follows:
 - For floating output, two-pole protection.
 - For output with positive referenced to earth, single-pole protection in negative pole.
 - For output with negative referenced to earth, single-pole protection in positive pole.

The type of output protection is also applicable to the battery switch or protection and to any DC distribution protection.

- All of the protections or disconnectors of the system must be in the 'Off' position and, in particular, that of the batteries of the device (**F/Q3**) and its counterpart (**F/Q8**) in the battery cabinet, when it has an external battery bank.

 Since the fuses of the disconnectors are supplied already installed to prevent them from being lost or mislaid, it is important to check that the disconnectors are open (Off).

7.7.1. Floating output.

- Connect the loads or busbar to the output terminals (**X6**) and (**X9**), respecting the colour of the cables (red for positive and black for negative) and the polarity indicated on the labelling of the device.
- Connect the load or loads to the earth terminal or strip (**X5**).
- It is recommended to distribute the output on different lines and each with protection elements (disconnectors with fuses or circuit breakers), to be installed by the customer and of **two-pole** type.

7.7.2. Output with positive connected to earth.

- Connect the loads or busbar to the output terminals (**X6**) and (**X9**), respecting the colour of the cables (red for positive and black for negative) and the polarity indicated on the labelling

of the device.

- Connect the load or loads to the earth terminal or strip (**X5**).
- It is recommended to distribute the output on different lines and each with protection elements (disconnectors with fuses or circuit breakers), to be installed by the customer and of **single pole in the negative pole** type.

7.7.3. Output with negative connected to earth.

- Connect the loads or busbar to the output terminals (**X6**) and (**X9**), respecting the colour of the cables (red for positive and black for negative) and the polarity indicated on the labelling of the device.
- Connect the load or loads to the earth terminal or strip (**X5**).
- It is recommended to distribute the output on different lines and each with protection elements (disconnectors with fuses or circuit breakers), to be installed by the customer and of **single pole in the positive pole** type.

7.8. Useful for the TSS maintenance services (**X37**) (optional).

- The rectifier has a Schuko power socket (**X37**), powered directly from the AC mains through auxiliary terminals (**X1A**) and (**X4A**) and protected by circuit breaker switch (**Q10**).
The use of this power socket is reserved for the maintenance services of our **TSS**.

7.9. Connection of auxiliary terminals (**X43**) and (**X43A**). Optional auxiliary contacts block (**F/Q8**).

- When the 'Battery fuse trip or opening' alarm is required, it will be necessary to incorporate an auxiliary contacts block into the corresponding protection to report the alarm to the communications module and this in turn to the control panel with LCD display.

This alarm can be grouped with others already available or associated with a specific relay.

- In cabinets shared by rectifier and batteries, it will not be necessary to make any implicit connection, since it is internally connected at the factory.

However, in external battery cabinets where the 'Battery fuse trip or opening' alarm (**F/Q8**), is required, it will be necessary to take the normally closed (NC) contact of this protection to the rectifier cabinet so that the control panel can inform promptly and/or send the alarm through the relay interface.

Make the following connection:

- Using two cables of at least 1 mm², connect pins **1** and **3** of terminal (**X43**) of the rectifier cabinet with pins **1** and **3** of terminal (**X43A**) of the battery cabinet. The connection order does not matter.

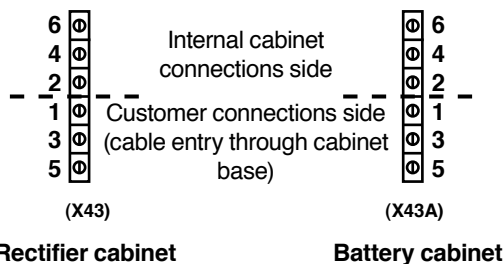



Fig. 16. Battery cabinet protection auxiliary contact terminal block pin arrangement.

7.10. Optional electrolyte level sensor, terminal (X25A).

-  The communications line (interface) constitutes a very low voltage safety circuit. To preserve its quality, it must be installed separately from other lines carrying dangerous voltages (power distribution lines).
- The open batteries, PbCa, NiCd, etc., are supplied from the factory with the appropriate level of electrolyte. It is however possible for the level to drop over time due to excess charging and discharging, high outside temperatures or other factors. Although the electrolyte level of all elements is always checked during periodic preventative maintenance, a drop in liquid in the same device can be considered similar, if not identical, for all of the accumulators. In order to ensure greater and permanent control over this parameter, an electrolyte level sensor can be installed in one of the batteries as an option. This sensor is supplied mounted on a cell stopper for one of the batteries.

Conceptually, when the sensor enters into contact with the electrolyte, which acts as a conductor, a circuit is closed. In the event of a drop in liquid, the sensor will stop conducting when the circuit is opened and consequently the alarm will be activated on the control panel display.

- Proceed as follows.
 - In shared cabinet for DC Power-L and batteries:
 - The sensor is pre-connected at the factory to the communications module and is left clamped to the frame of the cabinet at the height of one of the battery trays and with the necessary cable clearance to allow the extraction of the corresponding tray. Cut the clamp to release it.
 - Remove screws (**BL**) in mechanical locking mode, to release the corresponding battery tray and remove it.
 - Remove the stopper from one of the accumulators, preferably one from the middle of the battery pack, and replace it with the one that incorporates the sensor.
 -  Check that the stopper with the sensor has been inserted completely and is correctly in contact with the electrolyte.
 - Reinsert the battery tray and replace screws (**BL**) in mechanical locking mode.
 - In battery cabinet separate from the DC Power-L:
 - In the case of systems with more than one cabinet, the electrolyte level sensor is located in the cabinet with terminal (**X25A**).
 - The sensor is pre-connected at the factory to terminal

(**X25A**) and is left clamped to the frame of the cabinet at the height of one of the battery trays and with the necessary cable clearance to allow the extraction of the corresponding tray. Cut the clamp to release it.

- Remove screws (**BL**) in mechanical locking mode, to release the corresponding battery tray and remove it.
- Remove the stopper from one of the accumulators, preferably one from the middle of the battery pack, and replace it with the one that incorporates the sensor.
 -  Check that the stopper with the sensor has been inserted completely and is correctly in contact with the electrolyte.
- Remove the two-wire hose (**MD**) from inside the rectifier cabinet and connected at its opposite end (**X25A**) through wall bushings (**PR**) located on its base and insert it into the battery cabinet through the respective wall bushings (**PR**) located on its base. Connect the two hose cables (**MD**) interchangeably to terminals 1 and 3 of terminal (**X25A**).
- Reinsert the battery tray and replace screws (**BL**) in mechanical locking mode.

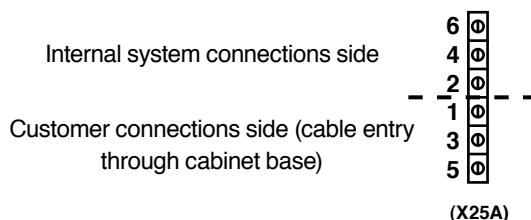

Fig. 17. Triple-deck terminal block pin arrangement, electrolyte level sensor auxiliary contact in battery cabinet.

7.11. COM communications module (optional).

- The system incorporates a communications module described in user manual EN030*.

8. Rectifier startup and shutdown.

- All of the protections or disconnectors of the system must be in the 'Off' position and, in particular, that of the the batteries of the device (**F/Q3**) and its counterpart (**F/Q8**) in the accumulator cabinet, when it has an external battery bank.



Since the fuses of the disconnectors are supplied already installed to prevent them from being lost or mislaid, it is important to check that the disconnectors are open (Off).

- Check that the instructions in Chapter 7 of Installation have been followed.
- With the loads in standby, apply mains voltage to the input terminals:

- Single-phase devices.
 - Main power supply network terminals (**X1**) and (**X4**).
 - Auxiliary power supply network terminals (for **TSS**) (**X1A**) and (**X4A**).
- Three-phase devices.
 - Main power supply network terminals (**X1**), (**X2**) and (**X3**).
 - Auxiliary power supply network terminals (for **TSS**) (**X1A**) and (**X4A**).

- **Notes regarding types of battery charging.**

- Quick charging is carried out automatically when the rectifier is started. Under normal working conditions and if the batteries are not at 100%, quick charging is activated until the level is reached.

When a mains failure occurs, the batteries discharge to a greater or lesser extent. When the mains return, quick charging is activated automatically.

Quick charging can also be started manually via the control panel with LCD display (see Screen 2.2 of Fig. 17).

Cyclically, every 6 months, counted from the last activation, quick charging is activated either automatically or manually.

- Exceptional charging.



Exceptional charging is forced manually at the will of the operator via the control panel (see Screen 2.3 of Fig. 17).

- If this occurs, set general input switch (**F/Q1A**) of the device and its switch on the protections panel to 'Off.'

Swap two of the phases on the input terminals and repeat the startup process described so far.

- Set general two-pole output switch (**F/Q2**) to 'On.'
The system is operational.
- Start the loads.

8.2. Shutdown procedure.

- Stop the loads.
- Set general two-pole output switch (**F/Q2**) to 'Off.'
-  The system output disconnector **IS NOT LOAD-SECTIONABLE TYPE**.
- Set general three-pole input switch (**F/Q1A**) to 'Off.'
- In systems with accumulators in a separate cabinet, set two-pole battery disconnector with fuses (**F/Q8**) to 'Off.'
- Set two-pole battery disconnector with fuses (**F/Q3**) to 'Off.'
-  The protection of the batteries of the system and/or of the accumulator cabinet **IS NOT LOAD-SECTIONABLE TYPE**. Do not maneuver over it when the system is supplying output voltage from the batteries.
The system is completely out of service.

8.1. Startup procedure

- Set two-pole battery disconnector with fuses (**F/Q3**) to 'On.'
- In systems with accumulators in a separate cabinet, set two-pole battery disconnector with fuses (**F/Q8**) to 'On.'
- Set general input switch (**F/Q1A**) to 'On.'
- In three-phase rectifiers:

If the following alarm message appears on the control panel display...

PHASE ROTATION ERROR

.. an audible alarm will also sound and the device will not be able to start, as the input phase sequence will be incorrect.

9. Control panel.

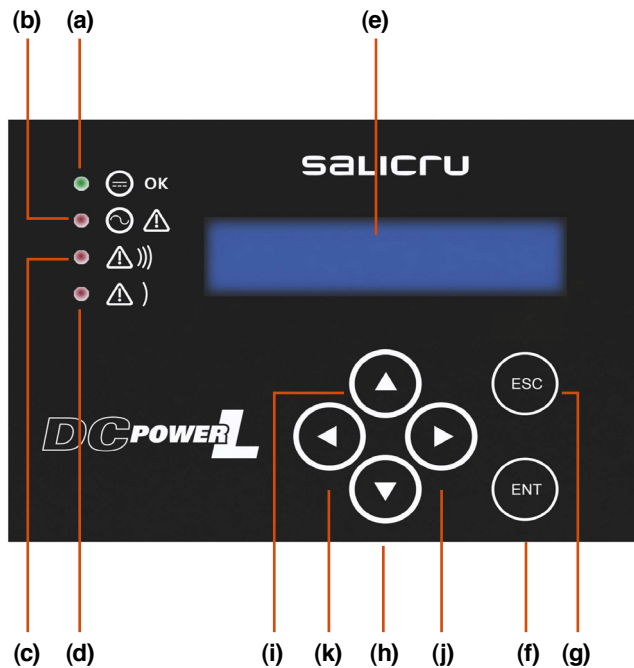

Fig. 18. Control panel with LCD display.

- The control panel basically consists of the following parts:
 - LED optical indications.
 - LCD display of 2x16 characters.
 - Keypad consisting of 6 keys.

9.1. Optical indications and alarm.

The optical indications (LEDs) of the synoptic illuminate when the alarm or state in question is activated.

- (a) Correct output indication: Device output within correct working range. In the event of incorrect output voltage, this indication will turn off.
- (b) Input fault indication: Input fault indication (both in single- and three-phase devices). This includes the trip alarm of the circuit breaker of the alternating supply or its absence.
- (c) Urgent alarm indication: This groups the blown fuse, charger fault and output fault alarms.
- (d) Non-urgent alarm indication: This groups the low electrolyte level and earth in battery alarms.

Optical indications (b), (c) and (d) are also supplied as alarms, through the interface relays (see user manual EN030* of the communications module).

The device also features an audible alarm that is activated with any of the alarms that can be seen on the LCD screen. The alarm is inhibited when it is acknowledged, that is, by pressing key 'ENT' for each alarm activated.

It is not possible to generally and permanently mute the audible alarm.

9.2. Basic functions of the keys and notes of interest.

- (e) LCD display.
 - (f) 'ENT' key.
 - (g) 'ESC' key.
 - (h) Forward key '▶'.
 - (i) Backward key '◀'.
 - (j) Right key '▶'.
 - (k) Left key '◀'.
- Use the forward '▶' and backward '◀' keys to access the screens of the root menu and be able to freely move from one to another with them.
 - Use the right '▶' and left '◀' keys to move inside each sub-menu.
 - The 'ENT' key has two functionalities:
 - Entry to sub-menus.
 - Recognition of an alarm.
 - The 'ESC' key enables you to return directly to the home screen just by pressing it, regardless of where you are.
 - On the screen map of Fig. 17, all of the sub-menus are exploded, including those that are 'Password' protected. Take into account the following annotations:
 - All of the screens include numbering located bottom right, as a reference for later description or clarification.
 - The Password hidden screens have a second annotation, located bottom left. This level of security prevents unauthorised personnel from tampering with any setting or programming.
 - On some screens, the maximum number of characters that the numerical or alphanumeric values shown on it can acquire are represented by an 'x', each of which corresponds to a digit.
 - It is not anticipated that the user can modify the factory settings, so the 'Password' is not supplied to enter on Screen 6.1 by specific requirements of the customer. Even so, on the screen map of Fig. 17, the whole map is shown exploded. If you require a modification or adjustment, contact our Technical Service and Support (TSS).

9.3. Description of the screens.

9.3.1. 'Home' screen menu.

Screen 0.1

This is the main screen of the system which appears when the device starts up. It is also the screen that appears when (ESC) is pressed to exit any of the other menus or sub-menus of the control panel with LCD display.

The first line shows the voltage and output current of the device and the second line shows the current battery charging mode, which can be any of the following:

- BATT. DISCHARGE: The batteries are discharging.
- BATT. FLOAT: The batteries are in float mode.

- BATT. QUICK CHARGING: The batteries are in quick charging mode.
- EXCEPTIONAL CHARGING: The batteries are in exceptional charging mode.

Screen 0.2

This screen shows the device's serial number.

Screen 0.3

This screen shows the device's software version.

9.3.2. 'Measurements' menu.

To access this menu from the home screen, press the forward key (↵) once. Use key (→) to access the screens of the different sub-menus and move freely from one to the other by means of keys (→) and (←).

Screen 1.1

Main screen of the measurements menu.

Screen 1.2

This shows the device's output voltage and current.

Screen 1.3

This shows the voltage and current of the batteries.

Screen 1.4

This screen shows the charge level of the batteries in Ah.

Screen 1.5, 1.6 and 1.7

These screens show the RMS values of the input voltage between the R-S, S-T and T-R phases respectively. For single-phase devices, only screen 1.8, which shows the voltage between phase and R-N neutral, is available.

Screen 1.8

This screen indicates the input voltage for single-phase devices.

Screen 1.9, 1.10 and 1.11

These screens indicate the input currents of the three phases.

Screen 1.12

This screen indicates the input current for single-phase devices.

Screen 1.13

This indicates the frequency value of the device's input voltage.

Screen 1.14

This displays the heat sink (HS) and battery (BATT) temperatures in °C.

9.3.3. 'Manoeuvres' menu.

To access this menu from the home screen, press the forward key (↵) twice. Use key (→) to access the screens of the different sub-menus and move freely from one to the other by means of keys (→) and (←).

Screen 2.1

This is the gateway to the device's operations menu.

Screen 2.2

Manual and forced activation of quick charging.

Screen 2.3

Manual and forced activation of exceptional charging.

9.3.4. 'User Parameters' menu.

To access this menu from the home screen, press the forward key (↵) three times. Use key (→) to access the screens of the different sub-menus and move freely from one to the other by means of keys (→) and (←).

Screen 3.1

This is the gateway to the User Parameters menu.

Screen 3.2

Selection of the language of the display messages from among: Spanish, Catalan and English.

Screen 3.3

This shows the address and speed of the MODBUS protocol.

9.3.5. 'Alarms' menu.

To access this menu from the home screen, press the forward key (↵) four times. Use key (→) to access the screens of the different sub-menus and move freely from one to the other by means of keys (→) and (←).

All of the alarm activation and deactivation conditions are established in Table 7. Consult it to view the thresholds, limits or conditions for each of them.

Screen 4.1

This is the gateway to the device's Alarms menu.

Screen 4.2

This alarm is displayed when the leakage current of the batteries of the positive pole exceeds a certain value.

Screen 4.3

The alarm is activated when the electrolyte level of the battery in which the sensor is installed is below the pre-defined ideal.

It is necessary to consider that the level test is performed on a single battery and the result is accepted as generic for the others. Although unlikely but not impossible, the exceptional case may occur that the level is low in one or more batteries and is correct in the one where the sensor is installed.

Screen 4.4

The alarm warning appears when the device's output voltage exceeds a certain value.

Screen 4.5

This alarm appears when the device's output voltage is below a certain value.

Screen 4.6

This alarm appears when the device's battery voltage is above a certain value.

Screen 4.7

This alarm is displayed when the device's battery voltage is below a certain value.

Screen 4.8

This alarm is displayed when the device's battery is discharged.

Screen 4.9

This alarm is displayed when the output current exceeds the maximum allowed.

Screen 4.10

This alarm is displayed when the battery's charging current is too high.

Screen 4.11

This alarm is displayed when the battery's maximum discharging current is exceeded.

Screen 4.12, 4.13 and 4.14

For single-phase devices, the alarm appears on Screen 4.12 when the input voltage between the phase and neutral (R-N) is above the maximum value. Screens 4.13 and 4.14 are not available for this type of power supply network.

For three-phase devices, the alarm or alarms appear on Screens 4.12, 4.13 and 4.14, respectively, when the input voltage between phases R-S, S-T and T-R is above the maximum value.

Screen 4.15, 4.16 and 4.17

For single-phase devices, the alarm appears on Screen 4.15 when the input voltage between the phase and RN neutral is below the minimum value. Screens 4.16 and 4.17 are not available for this type of power supply network.

For three-phase devices, the alarm or alarms appear on Screens 4.15, 4.16 and 4.17, respectively, when the input voltage between phases R-S, S-T and T-R is below the minimum value.

Screen 4.18, 4.19 and 4.20

This alarm appears when an input overcurrent is detected in phases R, S and T, respectively.

Screen 4.21

This alarm appears when a fault occurs in the battery charger.

Screen 4.22

This alarm appears when a battery protection trip is detected.

Screen 4.23

This alarm is displayed when a rectifier protection trip is detected.

Screen 4.24

This alarm appears when the device's input switch is open.

Screen 4.25

This alarm appears when the voltage of the input line is below its minimum value.

Screen 4.26

This alarm indicates that the device's output switch is open.

Screen 4.27

This alarm is displayed when the device's heat sink temperature exceeds the maximum value.

Screen 4.28

This alarm appears when the temperature of the device's batteries exceeds the maximum value.

Screen 4.29

This alarm appears when there is a loading error in the device's configuration parameters.

Screen 4.30

This alarm appears when the connection order of the device's input power lines is incorrect.

Screen 4.31

This alarm appears when the output current of the rectifier exceeds a certain percentage with respect to the rated current of the device.

Screen 4.32

This alarm appears when the input voltage exceeds its maximum value. Only for single-phase devices.

Screen 4.33

This alarm appears when the input voltage is below its minimum value. Only for single-phase devices.

Screen 4.34

This alarm appears when the output current exceeds its maximum value (overload situation).

Screen 4.35

This alarm appears when an overtemperature is detected due to the failure of a fan.

Screen 4.36

This alarm appears when the leakage current of the batteries of the negative pole exceeds a certain value.

Screen 4.37 *

This alarm appears when a power cut is detected during the battery charging process.

Screen 4.38 *

This alarm appears when the battery charging process ends successfully.

Screen 4.39 *

This alarm appears when a battery charging process is started manually.

Screen 4.40 *

This alarm appears when the utilisation charge is lower than the minimum programmed.

* Screens accessible in certain versions of device.

9.3.6. 'Battery Settings' menu.

To access this menu from the home screen, press the forward key (↓) five times. Use key (→) to access the screens of the different sub-menus and move freely from one to the other by means of keys (→) and (←).

Screen 5.1

This is the gateway to the Battery Settings menu. If you enter the correct 'Password' on Screen 7.1, you can see and modify the parameters of the batteries in the adjacent screens. Otherwise, none of the screens in this menu will be displayed.

Screen 5.2 **

On this screen, you can consult and modify the number of batteries or elements that make up the block of accumulators connected in series, as well as their capacity and the charging current with respect to the capacity of the battery.

Consider that for banks of batteries in parallel, the total capacity of all, not individual elements, will be indicated.

Screen 5.3 **

Use to consult and modify each battery unit's float voltage.

Screen 5.4 **

Use to consult and modify each battery unit's cut-off voltage.

Screen 5.5 **

Use to consult and modify the batteries' float voltage compensation, according to the temperature in your location.

Screen 5.6 **

Use this screen to check and modify each battery unit's quick charging and periodic charging voltages.

Screen 5.7 **

Use this screen to check and modify the batteries' exceptional charging voltage.

Screen 5.8 **

Use this screen to check and modify the batteries' quick charging voltage.

Screen 5.9 **

Use to consult and modify the batteries' maximum quick charging time.

Screen 5.10

Use to consult and modify the batteries' manual charging time.

Screen 5.11 **

Use to consult and modify the batteries' periodic charging time.

Screen 5.12 **

Use this screen to check and modify the batteries' periodic charging interval.

Screen 5.13 **

Use this screen to consult and modify the batteries' exceptional charging voltage.

Screen 5.14

Use to consult and modify the batteries' exceptional charging time.

Screen 5.15 **

Use to consult and modify the batteries' exceptional charging interval.

Screen 5.16 **

Use this screen to consult and modify high battery voltage.

Screen 5.17 **

Use this screen to consult and modify low battery voltage.

Screen 5.18 **

Use this screen to consult and modify high output voltage.

Screen 5.19 **

Use this screen to consult and modify low output voltage.

Screen 5.20

Use this screen to consult and modify the rectifier overload alarm threshold.

Screen 5.21

Use this screen to check and modify the high battery charging current alarm threshold.

** Password-protected screens.

9.3.7. 'Rectifier Settings' menu.

To access this menu from the home screen, press the forward key (↓) six times.

Screen 6.1

This is the gateway to the Rectifier Settings menu.

Screen 6.2

Use to set the rectifier current limit.

Screen 6.3

Use to set the isolation failure alarm threshold.

** Password-protected screens.

9.3.8. 'Password' menu.

To access this menu from the home screen, press the forward key (↓) seven times.

** Password-protected screens

Screen 7.1

By entering the password on this screen, you can access the parameter settings of the batteries and rectifier of the previous sections.

Enter the password in the space between the brackets. In the adjacent 4-character field, the type or correlated user name will be displayed.

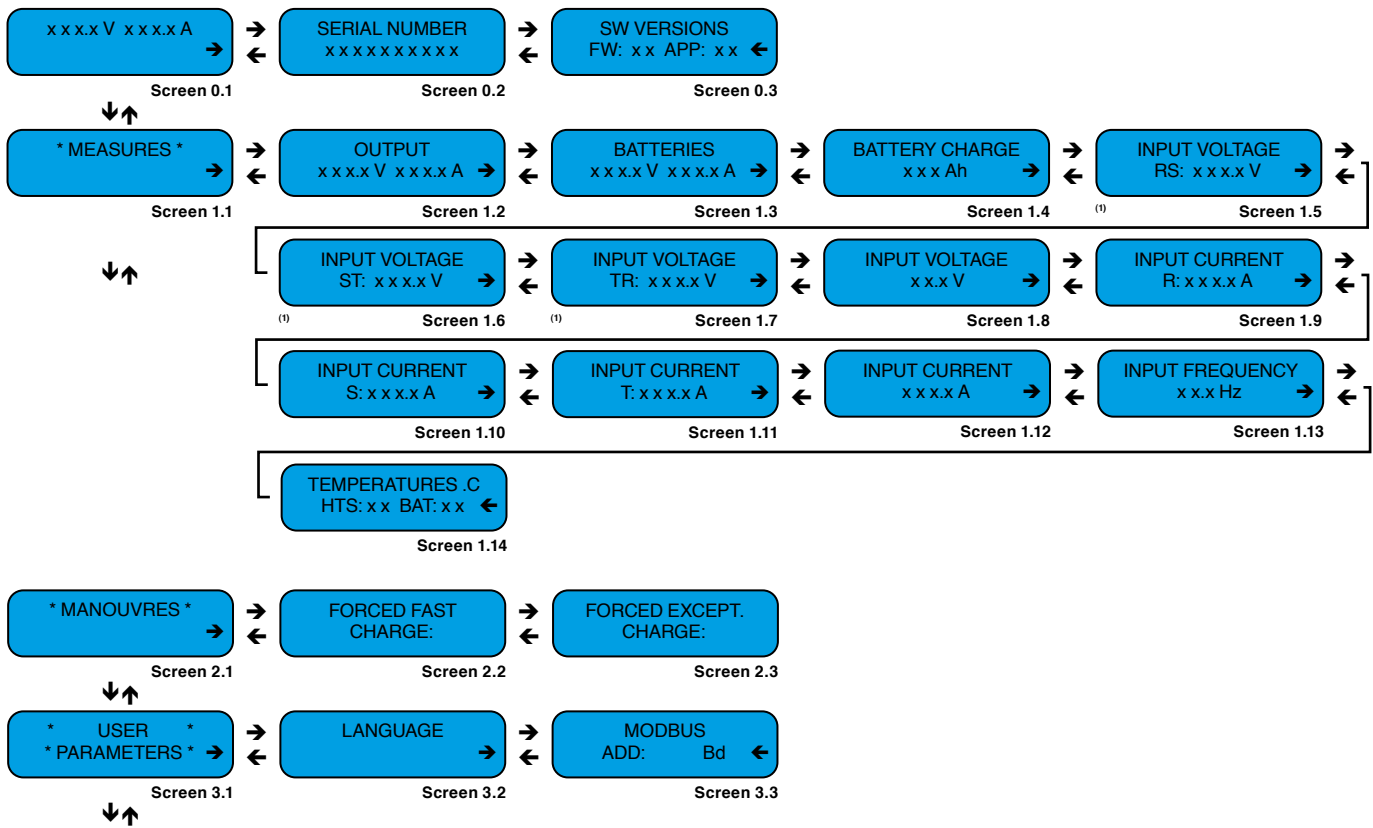

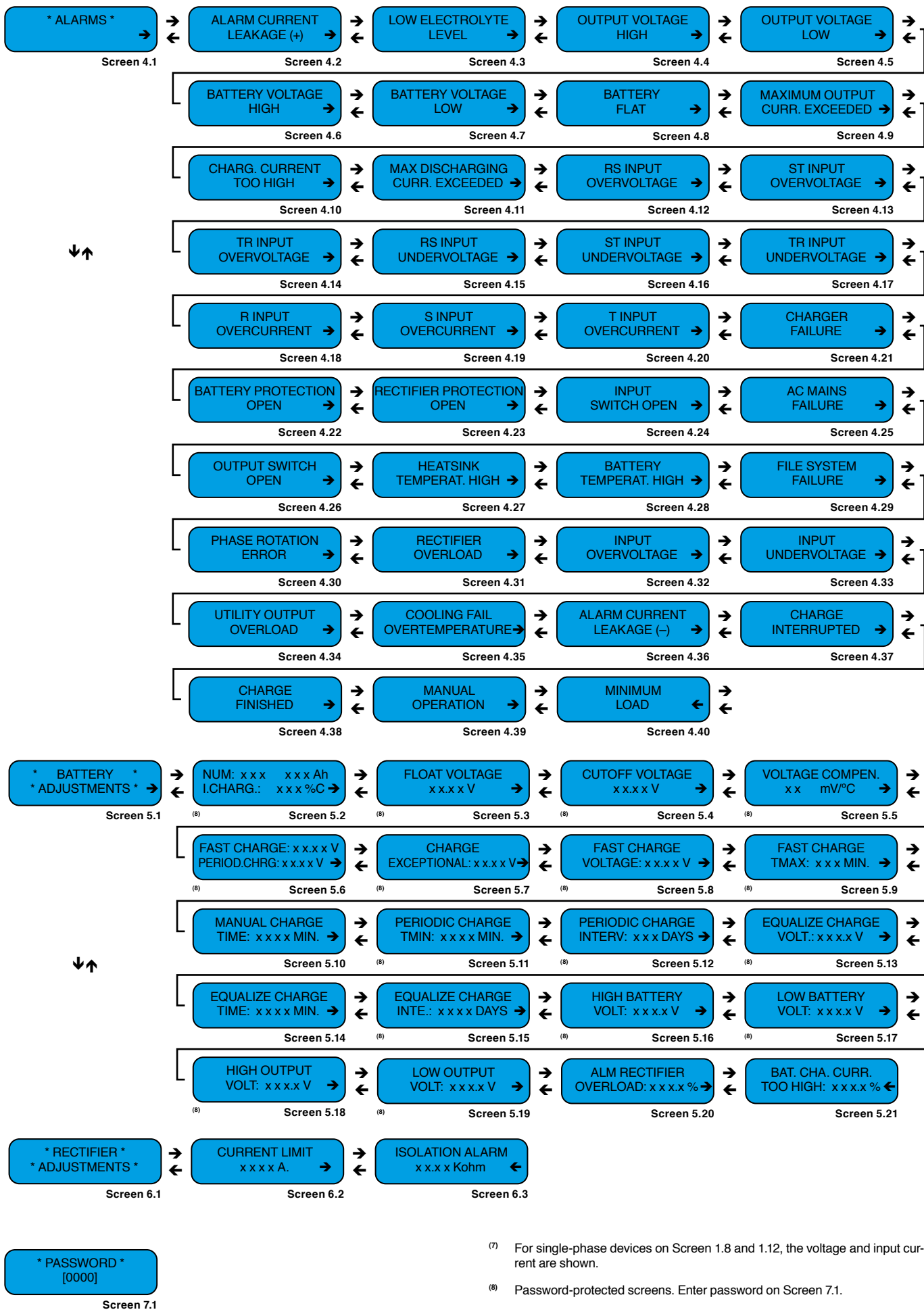

(7) For single-phase devices on Screen 1.8 and 1.12, the voltage and input current are shown.
 (8) Password-protected screens. Enter password on Screen 7.1.

Fig. 19. Control panel screens map.

Alarm	Activation condition	Deactivation condition	Category	Delay (s)
High output voltage alarm	Lead acid batteries: - Floating voltage x 1,05 NiCd batteries: - Boost charging voltage x 1,05	Manual reset using the boost / equalising buttons.	Urgent, Vout Not OK	40
Low output voltage alarm	10,2 x N x 1,03; where N is: - 2 for 24 Vdc - 4 for 48 Vdc - 9 for 110 Vdc - 10 for 125 Vdc - 18 for 220 Vdc	10,2 x N x 1,075; where N is: - 2 for 24 Vdc - 4 for 48 Vdc - 9 for 110 Vdc - 10 for 125 Vdc - 18 for 220 Vdc	Urgent, Vout Not OK	10
High battery voltage alarm	Lead acid batteries: - Floating voltage x 1,05 NiCd batteries: - Boost charging voltage x 1,05	Lead acid batteries: - Floating voltage x 0,97 NiCd batteries: - Boost charging voltage x 1,05	Urgent	10
Low battery voltage alarm	10,2 x N x 1,03; where N is: - 2 for 24 Vdc - 4 for 48 Vdc - 9 for 110 Vdc - 10 for 125 Vdc - 18 for 220 Vdc	10,2 x N x 1,075; where N is: - 2 for 24 Vdc - 4 for 48 Vdc - 9 for 110 Vdc - 10 for 125 Vdc - 18 for 220 Vdc	Urgent	180
AC input failure alarm	Vin < 0.80 x rated input voltage	Vin ≥ 0.84 x rated input voltage	AC failure	300
Input switch open alarm	Input switch open	Input switch closed	AC failure	10
RN or RS input undervoltage alarm ⁽⁹⁾	Vin RS < 0.90 x rated input voltage	Vin RS ≥ 0.94 x rated input voltage	AC failure	300
ST input undervoltage alarm ⁽⁹⁾	Vin ST < 0.90 x rated input voltage	Vin ST ≥ 0.94 x rated input voltage	AC failure	300
TR input undervoltage alarm ⁽⁹⁾	Vin TR < 0.90 x rated input voltage	Vin TR ≥ 0.94 x rated input voltage	AC failure	300
RN or RS input overvoltage alarm ⁽⁹⁾	Vin RS > 1.10 x rated input voltage	Vin RS ≤ 1.06 x rated input voltage	AC failure	30
ST input overvoltage alarm ⁽¹⁰⁾	Vin ST > 1.10 x rated input voltage	Vin ST ≤ 1.06 x rated input voltage	AC failure	30
TR input overvoltage alarm ⁽¹⁰⁾	Vin TR > 1.10 x rated input voltage	Vin TR ≤ 1.06 x rated input voltage	AC failure	30
Rectifier protection trip alarm	Protection open (auxiliary contact open)	Protection not open (auxiliary contact closed)	Urgent	10
Battery protection trip alarm	Protection open (auxiliary contact open)	Protection not open (auxiliary contact closed)	Urgent	5
Current leakage alarm.	Risol, approx. < 20KΩ	Risol, approx. > 30 KΩ	Not urgent	5
Electrolyte low level alarm	Electrolyte low level	Electrolyte normal level	Not urgent	1
Charger failure alarm	Abnormal rectifier operation due to internal problem, input voltage high ⁽¹¹⁾ , output voltage high, heat sink temperature high alarm for more than 10 min.	Manual reset using the quick/exceptional charging buttons.	Urgent	30
Output switch open alarm	Output switch open	Output switch closed	----	5
Heat sink temperature high alarm	T _{hs} > 85°C	T _{hs} ≤ 80°C	----	1
Battery temperature high alarm	T _{batt} > 45°C	T _{batt} ≤ 40°C	----	5
Phase rotation alarm	Connection of input phases incorrect.	Connection of input phases correct.	----	5
Battery high charging current alarm	Battery charging current at % with respect to the rated is over: I = HIGH BATTERY CHARGING CURRENT	Battery charging current at % with respect to the rated is below: I = 0.9 x HIGH BATTERY CHARGING CURRENT	----	5
Rectifier overload alarm	The output current of the rectifier has exceeded the percentage expressed in the 'RECT. OVERLOAD' parameter with respect to the rated.	The output current of the rectifier is below the percentage expressed in the parameter ('RECT. OVERLOAD' – 10%) with respect to the maximum.	----	5

⁽⁹⁾ For single-phase devices, the alarm corresponds to the voltage between the phase and the neutral (RN) and, for three-phase devices, between the RS phases.

⁽¹⁰⁾ Alarms only available for three-phase devices (ST and TR phases).

⁽¹¹⁾ Option.

Table 6. Alarm activation/deactivation conditions.

10. Maintenance.

10.1. Basic maintenance guide.

Batteries and capacitors must be replaced at the end of their service life.

 Dangerous voltages, even with respect to elements disconnected from the mains, as well as hot or very hot metal parts (heat sinks) can be found inside rectifier cabinets.

Direct contact can cause electrocution and burns. All operations, except the replacement of fuses located in the external disconnectors, must only be carried out by authorised technical personnel.

 When changing a fuse, always replace it with another of the same type, format and size.

10.1.1. Batteries.

The service life of the batteries greatly depends on the ambient temperature and other factors such as the number of charges and discharges, as well as their depth.

The estimated average life is 20 years, provided that the ambient temperature is controlled between 10 and 20°C.

 There is a risk of fire and/or explosion if the wrong type or number of batteries is used. Do not dispose of batteries in fire: they may explode. Do not open or break apart batteries: any electrolyte discharged can be harmful to the skin and eyes, and highly polluting to the environment. It can be toxic.

10.1.2. Capacitors.

The service life of the capacitors in the DC bus and those used for input and output filtering depends on use and environmental conditions. Preventative replacement by authorised technical personnel is recommended.

10.2. Warranty conditions.

The limited warranty provided by **our company** only applies to products that you acquire for commercial or industrial use in the normal course of your business.

10.2.1. Terms of the warranty.

On our website you will find the warranty conditions for the product you have purchased where you can also register it. You are recommended to do so as soon as possible so that it can be included in the database of our Technical Service and Support (**TSS**). Among other advantages, it will streamline any regulatory procedures for the intervention of **TSS** in the event of a fault.

10.2.2. Exclusions.

Our company will not be bound by the warranty if it notices that the defect in the product does not exist or was caused by improper use, negligence, improper installation and/or verification, attempts at unauthorised repair or modification, or any other cause beyond the intended use, or by accident, fire, lightning or other hazards. Nor shall it cover any compensation for damages.

10.3. Technical services network.

Information about our national and international Technical Service and Support (**TSS**) centres can be found on our website.

11. Annexes.

11.1. General technical specifications.

INPUT						
AC voltage (V)	Single-phase 230 V AC (3 wire: 1 phase + N + TT)					
	Three-phase 3x230 or 3x400 depending on model (4 wire: 3 phases + TT)					
Regulation range	± 15%. Outside this range, the corresponding alarm is activated. With input voltage of -20%, the rectifier is blocked and the loads continue to be powered from the batteries while backup is available					
Frequency (Hz)	50 / 60 ± 5% (47.5.. 57.. 63)					
Power factor	0.85 (with rated input, 100% load and floating output voltage)					
Performance 100% of load (%)	> 85					
OUTPUT						
Rated DC voltage (V)	24	48	110	120	125	220
Accuracy with batteries (%)	± 1					
Float voltage	2.28 V/cell (PbCa) / 1.4.. 1.45 V/el. (NiCd)					
Quick charging voltage	2.5 V/cell (PbCa) / 1.5 V/el. (NiCd)					
Exceptional charging voltage	2.7 V/cell (PbCa) / 1.65 V/el. (NiCd)					
Ripple voltage without batteries (%)	< 3					
Ripple voltage with batteries (%)	< 1					
Rectifier output current (A)	25 / 50 / 75 / 100 / 150 / 200					
BATTERIES						
Type	PbCa (sealed or open) or NiCd					
Rated DC voltage (V)	24	48	110	120	125	220
No. PbCa cells	10-12	22-24	50-56	55-60	55-62	100-110
Number of elements (NiCd)	19	38..39	81..86	88..94	92..96	161.. 173
Charge type	Constant I/U in accordance with DIN 41773					
Battery charging current	0.1.. 0.3 C adjustable					
Recharge time	Up to 80% in 4 hours (0.2 C)					
Protection	Against overvoltage and undervoltage					
Quick charging	Automatic according to established conditions or forced manually via the control panel					
Exceptional charging	Forced manually via the control panel and limited by conditions established for 365 days					
Float voltage/ambient temperature compensation	Yes, customisable according to battery specifications (mV / °C)					
PROTECTION AND OPERATION ELEMENTS						
Rectifier input	Circuit breaker					
Auxiliary input for TSS	Circuit breaker					
Batteries (in system cabinet)	Fuses					
Batteries (in external cabinet)	Fuses					
General output	Disconnecter					
Soft start	Yes					
COMMUNICATION AND ALARMS						
Slot	Yes, one pre-connected as standard					
SNMP / Remote maintenance	NIMBUS, optional					

DB9 connector (COM1)	Optional
DB9 connector (COM3)	Optional
Relay interface (RELAYS), potential-free contacts	3 relays, expandable to 6. Optional.
Compensation of battery voltage according to temperature	By means of a sensor installed in the battery set
Low electrolyte level (for open type batteries)	Optional. By means of a sensor installed in one of the batteries
GENERAL	
Dielectric strength	2500 V AC for 1 minute
Protection rating	IP20
Ventilation	Natural convection
Rectifier operating temperature	-10 °C to +55 °C ⁽¹¹⁾
Rectifier storage temperature	-20 °C to +70 °C ⁽¹²⁾
Relative humidity	Up to 95% non-condensing
Maximum operating altitude	Up to 3,000 masl ⁽¹³⁾
Acoustic noise at 1 metre	< 49 dBA (average) < 57 dBA (max. value)
Colour	Cabinet structure and covers painted in RAL-7035
Structure, supports and accessories	Pre-formed and galvanised sheet steel
Battery trays	Galvanised sheet steel
Weights (kg)	Depending on configuration
Dimensions (mm)	Depending on configuration, see Table 1
LCD DISPLAY	
Screen map menus (Fig. 15)	<ul style="list-style-type: none"> - Main - Measurements - Operations - User Parameters - Alarms - Battery Settings - Password (necessary to display 'Battery Settings' menu)
LUMINESCENT INDICATIONS	
LED optical on the control panel with LCD display	<ul style="list-style-type: none"> a) Correct output indication b) Input fault indication c) Urgent alarm indication d) Non-urgent alarm indication
STANDARDS	
Safety	IEC/EN 61204-7, IEC 60146-1-1
Electromagnetic compatibility (EMC)	IEC/EN 61204-3
Marking	CE
Quality and environmental management	ISO 9001 and ISO 14001
Certification company	SGS

⁽¹¹⁾ Power degradation from +40°C.

⁽¹²⁾ No batteries.

⁽¹³⁾ Power degradation from 1000 masl.

Table 7. General specifications.

11.2. Glossary.

- **AC.-** Alternating current is electric current in which the magnitude and direction vary cyclically. The waveform of the most commonly used alternating current is that of a sine wave, since this achieves a more efficient transmission of energy. In certain applications, however, other periodic waveforms are used, such as triangular or square.
- **DC.-** Direct current is the continuous flow of electrons through a conductor between two points with different potential. Unlike AC, in DC, electrical loads always circulate in the same direction from the point of greatest potential to the lowest. Although DC is commonly identified as a continuous current (for example, that supplied by a battery), any current that always maintains the same polarity is continuous.
- **GND.-** This stands for GROUND or EARTH and, as the name indicates, refers to the potential of the surface of the Earth.
- **Rectifier.-** In electronics, a rectifier is the element or circuit that converts AC into DC. This is done by using rectifier diodes, whether solid state semiconductors, vacuum valves or gaseous valves, such as those containing mercury vapour. Depending on the characteristics of the AC power that they use, they are classified as single-phase when they are powered by a mains phase or three-phase when they are powered by three phases. Depending on the type of rectification, they can be half wave when only one of the half cycles of the current is used or full wave when both half cycles are used.
- **Thyristor (gr.: gate).-** An electronic component consisting of semiconductor elements that uses internal feedback to produce switching. Its materials are of semiconductor type, that is to say, depending on their temperature, they can function as insulators or conductors. It is a one-way device because it only transmits the current in a single direction. It is generally used to control electrical power.

Some sources define the thyristor and silicon controlled rectifier (SCR) as synonyms; others define the SCR as a type of thyristor, along with DIAC and TRIAC devices.
- **Battery.-** A device capable of storing electricity in the form of chemical energy and, later, using electrochemical procedures, producing electrical energy. This cycle can be repeated for a certain number of times. It is a secondary electrical generator; that is, a generator that cannot operate without electricity being previously supplied through a charging process.
- **Interface.-** In electronics, telecommunications and hardware, an interface (electronics) is the port (physical circuit) through which signals are sent or received from one system or subsystem to another
- **LCD.-** Liquid crystal display, a device invented by Jack Janing, who was an employee of NCR. It is an electrical system for data presentation formed by 2 transparent conductive layers and a special crystalline material in the middle (liquid crystal) which have the ability to orientate light as it passes through.
- **LED.-** Light-emitting diode, a semiconductor device (diode) that emits light that is almost monochromatic, that is to say, it has a very narrow spectrum when it is polarised directly and is penetrated by an electric current. The colour (wavelength) depends on the semiconductor material used in the construction of the diode, and can vary from ultraviolet, passing through the visible light spectrum, to infrared, the latter called IRED (infra-red emitting diode).
- **Circuit breaker.-** A circuit breaker is a device capable of interrupting the electrical current of a circuit when it exceeds certain maximum values.



A series of horizontal dotted lines for writing, starting from the first line below the icon and extending to the bottom of the page.



A series of horizontal dotted lines for writing, starting from the top and extending to the bottom of the page.

SALICRU

Avda. de la Serra 100
08460 Palautordera
BARCELONA
Tel. +34 93 848 24 00
sst@salicru.com
SALICRU.COM



Information about the technical support and service network (TSS), the sales network and the warranty is available on our website:

www.salicru.com

Product range
Uninterruptible Power Supplies (UPS)
Stabilisers - Lighting flow dimmers
Power supplies
Variable frequency drives
Static inverters
Photovoltaic inverters
Voltage stabilisers



@salicru_SA



www.linkedin.com/company/salicru

SALICRU

