

USER MANUAL



UNINTERRUPTIBLE POWER SUPPLIES (UPS)

SLC TWIN RT2 LION

1.. 3 kVA

salicru

General index.

1. INTRODUCTION.

- 1.1. THANK YOU LETTER.

2. SAFETY INFORMATION.

- 2.1. USING THIS MANUAL.
 - 2.1.1. Conventions and symbols used.

3. QUALITY ASSURANCE AND STANDARDS.

- 3.1. STATEMENT BY THE MANAGEMENT.
- 3.2. STANDARDS.
 - 3.2.1. First and second environment.
 - 3.2.1.1. First environment.
 - 3.2.1.2. Second environment.
- 3.3. UKCA PRODUCT MARK AND UK AUTHORIZED REPRESENTATIVE.
- 3.4. ENVIRONMENT.

4. PRESENTATION.

- 4.1. VIEWS.
 - 4.1.1. Views of the device.
- 4.2. DEFINITION OF THE PRODUCT.
 - 4.2.1. Nomenclature.
- 4.3. OPERATING PRINCIPLE.
- 4.4. UPS OPERATING MODES.
 - 4.4.1. Notable features.
- 4.5. OPTIONAL EXTRAS.
 - 4.5.1. Isolation transformer.
 - 4.5.2. Exterior manual maintenance bypass.
 - 4.5.3. Communication card.
 - 4.5.3.1. Integration into computer networks using an SNMP adapter.
 - 4.5.3.2. RS-485 modbus.
 - 4.5.3.3. Relay interface.
 - 4.5.4. Extendable guide kits for mounting in a rack cabinet.

5. INSTALLATION.

- 5.1. RECEPTION OF THE DEVICE.
 - 5.1.1. Reception, unpacking and contents.
 - 5.1.2. Storage.
 - 5.1.3. Unpacking.
 - 5.1.4. Transport to the site.
 - 5.1.5. Siting, immobilising and considerations.
 - 5.1.5.1. Rotation of the control panel with LCD.

- 5.1.5.2. Vertical tower-type mounting.
- 5.1.5.3. Mounting as a rack in a 19" cabinet.
- 5.1.5.4. Preliminary considerations before connection.
- 5.1.5.5. Preliminary considerations before connection, regarding the batteries and their protections.
- 5.1.5.6. Connection elements.
- 5.2. CONNECTIONS.
 - 5.2.1. Connection of the input.
 - 5.2.2. Connection to the IEC output connectors.
 - 5.2.2.1. Connecting the loads.
 - 5.2.3. Terminals for EPO (emergency power off).
 - 5.2.4. Communication port.
 - 5.2.4.1. RS-232 and USB port.
 - 5.2.5. Smart slot for the integration of an electronic communication unit.
 - 5.2.6. Protection against voltage spikes for the modem / ADSL / fax, etc., line. .
 - 5.2.7. Software.
 - 5.2.8. Considerations before startup with connected loads.

6. OPERATION.

- 6.1. START-UP.
 - 6.1.1. Checks before start-up.
- 6.2. UPS STARTUP AND SHUTDOWN.
 - 6.2.1. UPS startup with mains voltage.
 - 6.2.2. UPS startup without mains voltage.
 - 6.2.3. UPS shutdown with mains voltage.
 - 6.2.4. UPS shutdown without mains voltage.

7. CONTROL PANEL WITH LCD.

- 7.1. GENERAL INFORMATION FOR THE SERIES.
 - 7.1.1. Information represented by the display.
 - 7.1.2. Common messages shown on the LCD display.
 - 7.1.3. Common abbreviations shown on the display.
- 7.2. CONTROL PANEL
 - 7.2.1. Composition of the control panel with LCD display.
 - 7.2.2. Audible alarms.
 - 7.2.3. Location of the setting parameters on the display.
 - 7.2.4. Settings.
 - 7.2.4.1. Operating mode / Description of state.
 - 7.2.4.2. Warning or alert indicators.
 - 7.2.4.3. Error or fault codes.

8. MAINTENANCE, WARRANTY AND SERVICE.

- 8.1. BATTERY MAINTENANCE.
- 8.2. UPS TROUBLESHOOTING GUIDE.
 - 8.2.1. Troubleshooting guide.
- 8.3. WARRANTY CONDITIONS.
 - 8.3.1. Terms of the warranty.
 - 8.3.2. Exclusions.
- 8.4. TECHNICAL SERVICES NETWORK.

9. ANNEXES.

- 9.1. GENERAL TECHNICAL SPECIFICATIONS.
- 9.2. GLOSSARY.

1. INTRODUCTION.

1.1. THANK YOU LETTER.

We thank you in advance for the trust placed in us in the purchasing of this product. Read this instruction manual carefully in order to familiarise yourself with its content, since the more you know and understand the device the greater your satisfaction, level of safety and optimisation of its functionalities will be.

We remain at your disposal for any additional information or queries that you may wish to make.

Yours sincerely.

SALICRU

- The device described here **is capable of causing significant physical injury if improperly handled**. For this reason, its installation, maintenance and/or repair must be carried out exclusively by our staff or **qualified personnel**.
- Although no effort has been spared to ensure that the information in this user manual is complete and accurate, we accept no liability for any errors or omissions that may exist.

The images included in this document are for illustrative purposes and may not exactly represent the parts of the device shown; therefore they are not contractual. However, any divergence that may arise will be remedied or solved with the correct labelling on the unit.

- Following our policy of constant evolution, **we reserve the right to modify the characteristics, operations or actions described in this document without prior notice**.
- **Reproduction, copying, assignment to third parties, modification or total or partial translation** of this manual or document, in any form or by any means, **without previous written permission by us is prohibited**, with the company reserving full and exclusive property rights over it.

2. SAFETY INFORMATION.

2.1. USING THIS MANUAL.

The documentation of any standard equipment is available to the customer on our website for download (www.salicru.com).

- For devices 'powered by socket,' this is the website for obtaining the user manual and '**Safety Instructions**' EK266*08.
- For devices with 'permanent connection' via terminals, a CD-ROM or pen drive containing all necessary information for connection and startup, including '**Safety Instructions**' EK266*08, may be supplied with it.

Before carrying out any action on the device relating to its installation or startup, change of location, configuration or handling of any kind, carefully read the safety instructions.

The purpose of the user manual is to provide information regarding safety and explanations of the procedures for installation and operation of the equipment. Read them carefully and follow the steps indicated in the order established.



Compliance with the 'Safety Instructions' is mandatory and the user is legally responsible for compliance and enforcement.

The device is delivered properly labelled for correct identification of each of its parts, which, together with the instructions described in this user manual, allows installation and start-up operations to be performed in a simple and organised manner without any doubts whatsoever.

Finally, once the equipment is installed and operating, it is recommended to save the documentation downloaded from the website, CD-ROM or pen drive in a safe and easy-to-access place, for any future queries or doubts that may arise.

The following terms are used interchangeably in the document to refer to:

- '**SLC TWIN RT2 LION, TWIN RT2, TWIN, RT2, device, unit or UPS**' - Uninterruptible power supply.
Depending on the context of the phrase, it can refer either to the actual UPS itself or to the UPS and the batteries, regardless of whether or not it is all assembled in the same metal enclosure.
- '**Batteries**' or '**accumulators**' - Bank or set of elements that stores the flow of electrons by electrochemical means.
- '**T.S.S.**' - Technical Service and Support.
- '**Customer, installer, operator or user**' - These are used interchangeably and by extension to refer to the installer and/or operator who will carry out the corresponding actions, and the same person may be responsible for carrying out the respective actions when acting on behalf, or in representation, of the above.

2.1.1. Conventions and symbols used.

Some symbols may be used and appear on the device, batteries and/or in the context of the user manual.

For more information, see Section 1.1.1 of the '**Safety Instructions**' document EK266*08.

3. QUALITY ASSURANCE AND STANDARDS.

3.1. STATEMENT BY THE MANAGEMENT.

Our goal is customer satisfaction, therefore this Management has decided to establish a Quality and Environment Policy, through the implementation of a Quality and Environmental Management System that will enable us to comply with the requirements demanded in the **ISO 9001** and **ISO 14001** and also by our Customers and Stakeholders.

Likewise, the management of the company is committed to the development and improvement of the Quality and Environmental Management System, through:

- Communication to the entire company of the importance of satisfying both the customer's requirements as well as legal and regulatory requirements.
- The dissemination of the Quality and Environment Policy and the setting of the Quality and Environment objectives.
- Conducting reviews by the Management.
- Providing the necessary resources.

3.2. STANDARDS.

The **SLC TWIN RT2 LION** product is designed, manufactured and marketed from our **EN ISO 9001** Quality Assurance certified facilities. The **CE** marking indicates conformity with EC Directives through the application of the following standards:

- **2014/35/EU** - Low-voltage safety.
- **2014/30/EU** - Electromagnetic Compatibility (EMC).
- **2011/65/EU** - Restriction of the use of hazardous substances in electrical and electronic equipment (RoHS).

In accordance with the specifications of the harmonised standards. Reference standards:

- **EN-IEC 62040-1**. Uninterruptible power supplies (UPS). Part 1-1: General and safety requirements for UPS used in user access areas.
- **EN-IEC 62040-2**. Uninterruptible power supplies (UPS). Part 2: EMC requirements.



The manufacturer is not liable in the event of modification or intervention on the device by the user.



WARNING:

SLC TWIN RT2 LION from 1 to 3 kVA. This is a category C2 UPS. In a residential environment, this product may cause radio interference, in which case the user must take additional measures.

It is not appropriate to use this device in basic life support applications (BLS), where a failure of the former can render vital equipment out of service or significantly affect its safety or effectiveness. It is also not recommended in medical applications, commercial transport, nuclear installations, or other applications or loads, where a failure of the product can lead to personal or material damages.



The EC declaration of conformity of the product is available to the customer upon express request to our offices.

3.2.1. First and second environment.

The environment examples that follow cover most UPS installations.

3.2.1.1. First environment.

Environment including residential, commercial and light industry installations, directly connected, without intermediate transformers, to a low voltage public power grid.

3.2.1.2. Second environment.

An environment that includes all commercial, light industrial and industrial establishments that are not directly connected to a low voltage power grid supplying buildings used for residential purposes.

3.3. UKCA PRODUCT MARK AND UK AUTHORIZED REPRESENTATIVE.

UK CA product marking indicates that this UPS has been evaluated by Salicru and is deemed to comply with safety, health and environmental protection requirements.

The UK CA Declaration of Conformity is available upon request. For copies of the UKCA Declaration of Conformity, please contact Salicru or check our website: www.salicru.com

UK Authorised Representative

Indele Limited

7 Bell Yard,

WC2A 2JR,

London

3.4. ENVIRONMENT.

This product has been designed respecting the Environment and manufactured in our certified facilities according to the **ISO 14001 standard**.

Recycling of the device at the end of its useful life:

We undertake to use the services of authorised and regulatory-compliant companies to process all of the products when they are recovered at the end of their useful life (contact your distributor).

Packaging:

For the recycling of the packaging there must be compliance with the legal requirements in force, in accordance with the specific regulations of the country where the device is installed.

Batteries:

Batteries pose a serious hazard to health and the environment. They must be disposed of in accordance with the laws in force.

4. PRESENTATION.

4.1. VIEWS.

4.1.1. Views of the device.

Fig. 1 and Fig. 2 show illustrations of the devices according to box format and in relation to the model's power rating. However, because the product is constantly evolving, discrepancies or slight contradictions may arise. If in any doubt, the labelling on the device itself will always prevail.



The nameplate of the device shows all of the values relating to its main properties and characteristics. Act accordingly for its installation.

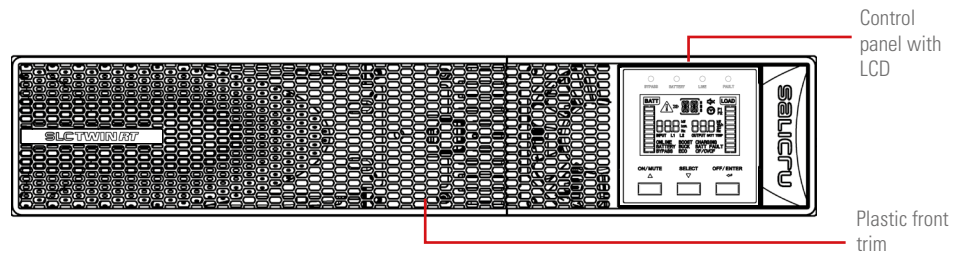

Fig. 1. Front view.

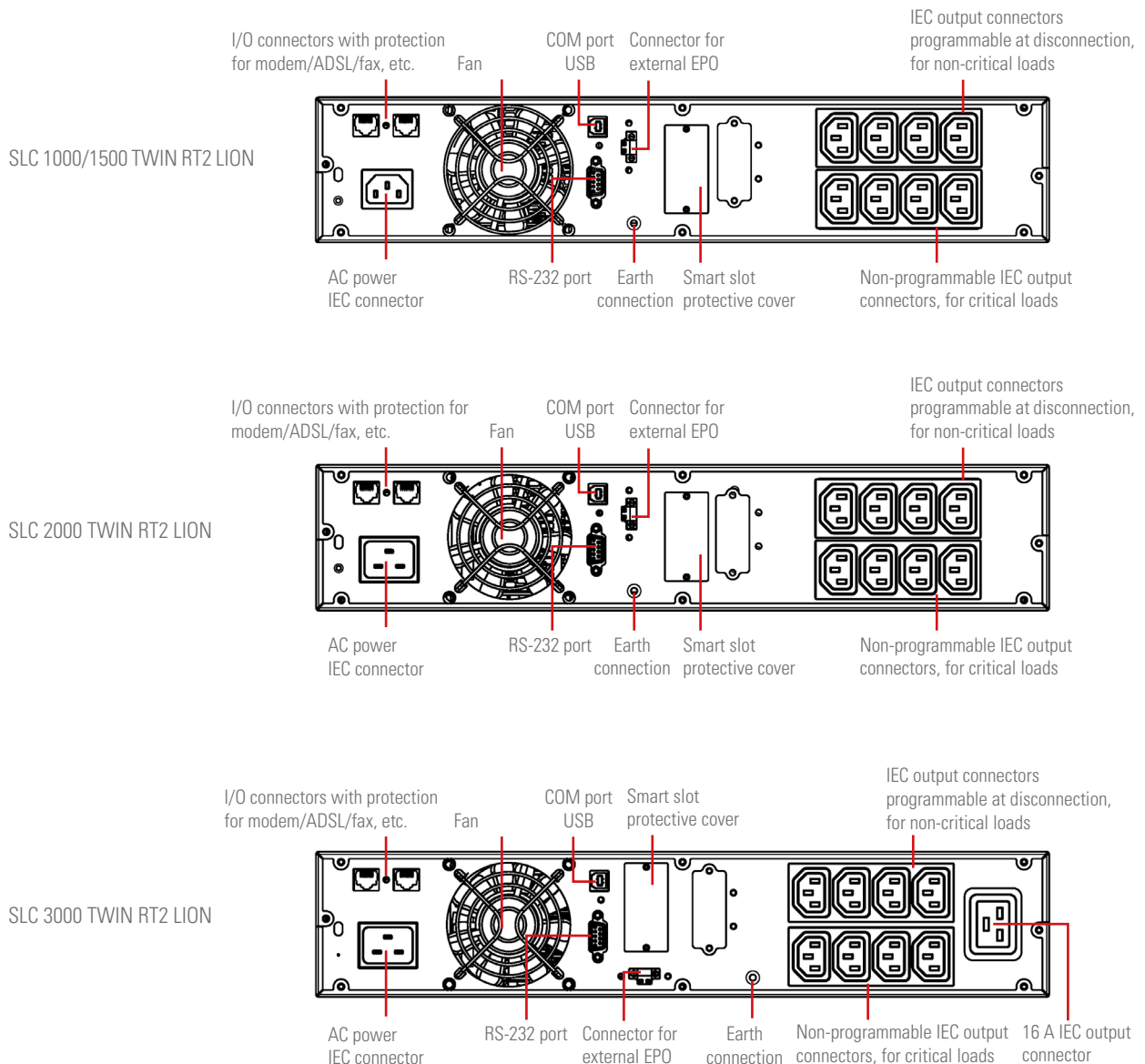
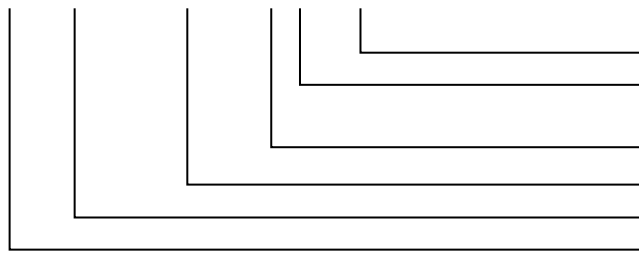

Fig. 2. Rear view of the the SLC TWIN RT2 LION models.

4.2. DEFINITION OF THE PRODUCT.

4.2.1. Nomenclature.

SLC-3000-TWIN RT2 LION WCO EE29503



EE*	Special customer specifications.
CO	'Made in Spain' marking on UPS and packaging (for customs purposes).
W	Private-label device.
TWIN RT2 LION	Device series.
3000	Power in VA.
SLC	Brand acronym (for UPS).

4.3. OPERATING PRINCIPLE.

This manual describes the installation and operation of the SLC TWIN RT2 LION series of Uninterruptible Power Supplies (UPS). SLC TWIN RT2 LION series UPSs ensure optimum protection of any critical load, maintaining the supply voltage of the loads between the specified parameters without interruption during failure, deterioration or fluctuation of mains power.

Thanks to their PWM (pulse width modulation) and double-conversion technology, SLC TWIN RT2 LION series UPSs are compact, cool, silent and high performance.

The double converter principle eliminates all mains power disturbances. A rectifier converts the AC current of the mains into DC current, thereby maintaining optimum battery charge level and powering the inverter, which, in turn, generates a suitable AC sine-wave voltage for continuously powering the loads. In the event that the UPS's input power supply fails, the Li-ion batteries will supply clean power to the inverter.

The design and construction of the SLC TWIN RT2 LION series UPS has been carried out in accordance with international standards.

Consequently, this series has been designed to maximise the availability of critical loads and to ensure that your business is protected against any variations in voltage, frequency, electrical noise, cuts or dropouts that may occur in the power supply. This is the primary goal of SLC TWIN RT2 LION series UPSs.

This manual applies to the standardised models shown in Tab. 1.



Characteristics and main advantages of Li-ion batteries.

Like lead-acid batteries, lithium-ion (Li-ion) batteries consist of four components: anode, cathode, electrolyte and separator.

Two compounds act as electrodes and are immersed in the electrolyte. The same material, lithium carbonate, is used for the anode in all Li-ion batteries. The material used for the cathode can vary. Li-ion batteries use lithium oxide (Li₂O).

Main advantages:

- **Increased energy density:** The accumulator's energy density determines the battery's capacity. The energy density of Li-ion batteries is approximately three times higher than that of lead-acid; thus, when comparing Li-ion and lead-acid batteries of similar size, the capacity of the former would be three times higher.

- **Increased energy efficiency and higher voltage:** Lithium is a highly electronegative chemical element. Its increased oxidation capacity means the voltage of Li-ion batteries is higher. While a lead-acid battery cell produces 2 V, a Li-ion cell produces in excess of 3.6 V. Overall performance levels, meanwhile, reach 98%.
- **Improved energy profile:** The energy profile measures the charge status in relation to charge time and battery use. Li-ion batteries boast a superior energy profile. Because they operate at a higher voltage, a less intense current is needed to produce the same amount of energy, meaning the battery needs less time to charge.
- **Depth of discharge:** While the useful life of lead-acid accumulators can be maximised if they are kept at just 20% discharge, and it is not recommended to let them discharge by more than 50%, Li-ion batteries do not suffer from this problem and can be discharged up to 100%.
- **Longer useful life:** Following on from the previous point, it should be noted that the useful life of a deep-cycle lead-acid monoblock is 600-700 charge-discharge cycles. In contrast, the useful life of a Li-ion battery is around 10 times longer, i.e. 6,000+ cycles.
- **Maintenance-free:** Li-ion batteries are sealed and do not require any form of maintenance.

4.4. UPS OPERATING MODES.

- Normal mode.

Device running supplying output voltage from the inverter. Mains power present with correct input voltage and frequency.

- Battery mode.

Device running with mains voltage or frequency out of range or without AC input power, either due to mains failure or absence of cable connection, supplying output voltage from the batteries.

- Bypass mode.

Device running or not, supplying output voltage directly from the AC mains.

With the inverter running, this operating mode may be due to an overload, blockage or inverter fault.

The actions for each incident will be as follows: Reduce the load connected to the output, unblock the device by resetting it - stop it and start it up again - and, if the blockage or fault remains, contact our **T.S.S.**

With the inverter shut down, the output supplies mains power directly through the static bypass of the device provided that it has AC input power.

- Frequency converter (CF) mode.

Operating mode of the UPS as a frequency converter. In this mode, the static bypass is disabled by the condition of disparate input and output frequencies.



Even if the LCD on the backlit control panel shows messages, it does not mean that the inverter is operational. It is switched on by pressing the 'ON' button on the control panel, see Chapter 6.

4.4.1. Notable features.

- True on-line with double-conversion technology and output frequency separate from the mains.
- Output power factor 0.9. Pure sine-wave waveform, suitable for all types of load.
- Input power factor > 0.99 and high overall performance (between 89% and 91%). Greater energy savings and lower user installation costs (wiring), as well as low distortion of the input current, which reduces pollution in the power supply network.
- Great adaptability to the worst conditions of the mains. Wide input voltage, frequency and waveform ranges, thus avoiding excessive dependence on limited battery power.
- Battery recharge time < 3h.
- Selectable high-efficiency mode (ECO MODE) > 95%. Energy savings, economically beneficial to the user.
- Possibility of starting the device without mains power supply or discharged battery. Pay attention to this last aspect because the more the batteries are discharged, the more the backup will be reduced.

- Intelligent battery management technology is very useful for extending the life of accumulators and optimising re-charge times.
- Standard communication options via the RS-232 serial port or USB port.
- Remote emergency power off control (EPO).
- Control panel with LCD display.
- Availability of optional connectability cards to improve communication capabilities.
- The device can be configured as a tower or rack using the accessories supplied. The control panel can be rotated to adapt to either format.

Model	Type	Input/output type
SLC-1000-TWIN RT2 LION	Standard	Single-phase / Single-phase
SLC-1500-TWIN RT2 LION		
SLC-2000-TWIN RT2 LION		
SLC-3000-TWIN RT2 LION		

Tab. 1. Standardised models.

4.5. OPTIONAL EXTRAS.

Depending on the configuration chosen, the device can include any of the following options:

4.5.1. Isolation transformer.

The isolation transformer provides galvanic isolation in order to completely isolate the output from the input and/or change neutral point treatment.

The placement of an electrostatic screen between the primary and secondary windings of the transformer provides a high level of electrical noise attenuation.

The isolation transformer can be physically placed at the input or output of the UPS depending on the technical conditions of the whole system (device supply voltage and/or load voltage, characteristics or their type, etc.).

It will always be supplied as a peripheral component external to the device itself in a separate enclosure.

4.5.2. Exterior manual maintenance bypass.

The purpose of this option is to electrically isolate the device from the mains and the critical loads without cutting the power to the latter. In this way, maintenance or repair operations on the device can be carried out without interruptions to the power supply of the protected system, while preventing unnecessary hazards for technical personnel.

4.5.3. Communication card.

The UPS features a slot at the rear for inserting one of the following communication cards.

4.5.3.1. Integration into computer networks using an SNMP adapter.

Large computer systems based on LANs and WANs that integrate servers in different operating systems must provide the system manager with ease of control and administration. This facility is obtained through an SNMP adapter, which is universally supported by the main software and hardware manufacturers.

Connection of the UPS to the SNMP is internal while that of the SNMP to the computer network is made through an RJ-45 10 base connector.

4.5.3.2. RS-485 modbus.

Large computer systems based on LANs and WANs often require that communication with any element that is integrated into the computer network be made through a standard industrial protocol.

One of the most used standard industrial protocols on the market is the MODBUS protocol.

4.5.3.3. Relay interface.

The UPS has, as an option, a relay interface card that provides digital signals in the form of potential-free contacts, with a maximum applicable voltage and current of 240 V AC or 30 V DC and 1 A.

This communication port enables dialogue between the device and other machines or devices through the relays supplied in the terminal block arranged on the same card, with a single common terminal for all of them.

From the factory, all contacts are normally open and can be changed one by one, as indicated in the information supplied with the optional extra.

The most common use of these types of ports is to provide the necessary information to the file-closing software.

For more information, contact our **T.S.S.** or our nearest distributor.

4.5.4. Extendable guide kits for mounting in a rack cabinet.

An extendable and unique guide kit is available for all device models, valid for any kind of rack-type cabinet.

These guides enable any TWIN RT2 LION unit to be installed like a rack in its respective cabinet.

5. INSTALLATION.



Read and respect the Safety Information, described in Chapter 2 of this document. Failure to obey some of the instructions described in this manual can result in a serious or very serious accident to persons in direct contact or in the vicinity, as well as failures in the device and/or loads connected to it.

In addition to the device's own user manual, a number of other documents are supplied along with the Quick Start guide. Consult them and strictly follow the indicated procedure.



During discharge, the equipment operates in IT (isolated earth) neutral mode. This means that the neutral is not directly connected to earth, providing an additional layer of safety and stability in critical situations. To ensure optimal and safe operation, follow the guidelines in the user manual and contact your distributor if you have any questions.

5.1. RECEPTION OF THE DEVICE.

Pay attention to section 1.2.1. of the safety instructions -EK266*08- in all matters relating to the handling, movement and siting of the unit.

Use the most suitable means to move the UPS while it is packed, with a pallet jack or forklift.

Any handling of the device must be carried out in accordance with the weights shown in the technical specifications according to the model, indicated in Chapter 9. Annexes.

5.1.1. Reception, unpacking and contents.

- Reception. Check that:
 - The data on the label affixed to the packaging corresponds to that specified on the order. Once the UPS is unpacked, check the previous data with those of the device nameplate.

If there are discrepancies, report the issue as soon as possible, citing the device's manufacturing number and delivery note references.
 - It has not suffered any mishaps during transportation (packaging in perfect condition).

If this is not the case, contact your distributor.
- Unpacking.
 - To check the contents, it will be necessary to remove the packaging.
 - Complete the unpacking according to the procedure of section 5.1.3.
- Contents.
 - 1 UPS.
 - Quick guide on paper.
 - Information for warranty registration.
 - 1 USB cable.
 - 3 cables with IEC connectors for loads.
 - 1 AC power cable - IEC 16A (2), (Schuko type in its standard version and BS type for the 2 kVA UK versions).
 - 1 AC power cable - IEC 60309 13A (BS type for 3 kVA

UK versions).

- 2 metal pieces for use as handles and screws for installing the unit in a rack cabinet.
- 4 plastic pieces for use as a base and screws to facilitate the arrangement of the UPS as a tower (vertical position).

Once the reception is completed, it is advisable to re-pack the UPS until it is put into service in order to protect it against mechanical shock, dust, dirt, etc.

The device's packaging consists of a cardboard box, expanded polystyrene corners and polyethylene cover and strapping, all of which can be recycled. When the packaging requires disposal, it must be carried out in accordance with current laws.

We recommend keeping the packaging for at least 1 year.

5.1.2. Storage.

The device should be stored in a dry, ventilated location protected from rain, dust, water splashes and chemical agents. It is advisable to keep each device and battery unit in its original packaging, as it has been specifically designed to ensure maximum protection during transportation and storage.



For devices that contain Li-ion batteries, the charging frequency and charge duration indicated in the table below (which are based on the device's storage temperature) must be observed, otherwise the warranty may be invalidated.

Storage temperature	Charging frequency	Charge duration
35°C ~ 45°C	Every month	1 h @ 5°C ~ 35°C
25°C ~ 35°C	Every 1-3 months	1 h @ 5°C ~ 25°C
-10°C ~ 25°C	Every 3-12 months	1 h @ 5°C ~ 25°C

Tab. 2. Frequency and duration of Li-ion battery charging based on storage temperature.

Then shut down the device, disconnect it and store the UPS and batteries in their original packaging, noting the new date for recharging the batteries on a document as a record or even on the packaging itself.

Do not store the devices where the ambient temperature exceeds 50°C or drops below -15°C, as this may cause degradation of the electrical characteristics of the batteries.

5.1.3. Unpacking.

The packaging of the device consists of a cardboard box, expanded polystyrene (EPS) or polyethylene foam (EPE) corners, polyethylene cover and strapping, all of which are recyclable materials; consequently, if it requires disposal, it must be carried out in accordance with current laws. We recommend keeping the packaging in case it needs to be used in the future.

Proceed as follows:

- Cut the straps around the cardboard box.
- Remove the accessories (cables, brackets, etc.)
- Remove the device from the packaging, using another person to help or suitable mechanical means where necessary, depending on the weight of the model.

- Remove the protective corners from the device and the plastic bag.
-  Do not leave the plastic bag within the reach of children to avoid danger of suffocation.
- Inspect the device before proceeding and, in the event of finding damage, contact the supplier or, failing that, our firm.

5.1.4. Transport to the site.

It is recommended to transport the UPS by means of a pallet jack or the most appropriate method considering the distance between the two points.

If the distance is considerable, it is recommended to transport the device in its packaging to the installation site and then unpack it.

5.1.5. Siting, immobilising and considerations.

All TWIN RT2 LION UPSs are designed to be mounted as a tower model (i.e. placed vertically) or rack model (i.e. placed horizontally) for installation in 19" cabinets.

Follow the instructions indicated in the sections relating to either of the two possibilities, according to the particular configuration of your device.

Fig. 3 to Fig. 5 provide illustrations of the device's design.

These illustrations provide help and guidance on the steps to follow, but the instructions are not intended to refer to a single model, although, in practice, the actions to be carried out are always the same for all of them.

For all instructions regarding connections, refer to section 5.2.

5.1.5.1. Rotation of the control panel with LCD.

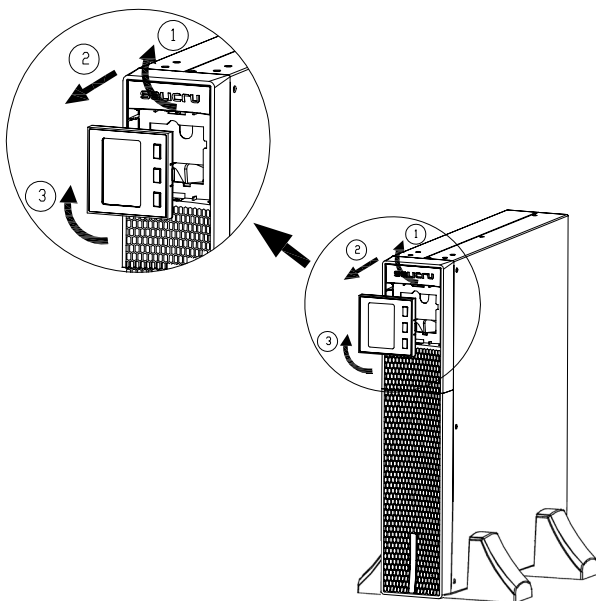

Fig. 3. Rotation of the control panel with LCD on the plastic front trim.

To facilitate the reading of messages on the display when the device is installed vertically, it is possible to rotate the control panel clockwise by 90° (see Fig. 3).

Likewise, reverse the rotation of the control panel if a device arranged as a tower needs to be installed as a rack.

In this case, the rotation of the control panel will be anti-clockwise.

Proceed as follows:

- Insert fingertips into the recesses of the plastic trim around the display and pull outwards.
- Rotate the control panel with LCD 90° to the right with respect to its initial position and insert it back into the front.

5.1.5.2. Vertical tower-type mounting.

- Rotate the control panel according to section 5.1.5.1.
- Take the 4 plastic pieces supplied with the equipment, two by two, fit them together and secure them with the supplied screws to obtain two pedestals or bases.
- Place the UPS upright between the two bases at a distance of 70 mm from each end (see Fig. 4).

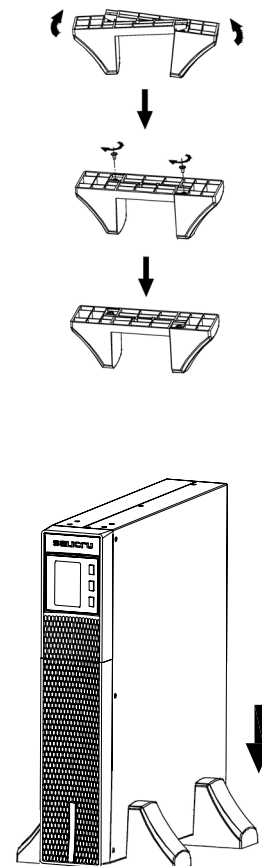

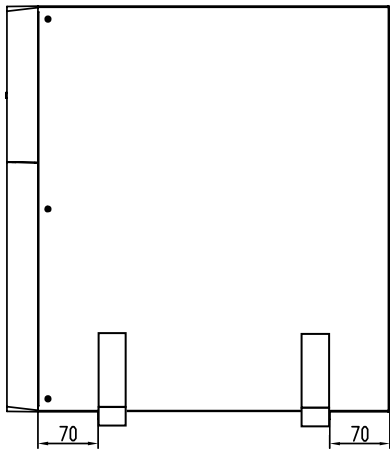

Fig. 4. Vertical tower-type mounting.

5.1.5.3. Mounting as a rack in a 19" cabinet.

To mount a device in a 19" rack cabinet, proceed as follows (see Fig. 5):

- Using the supplied screws, fix the two adapter angles for use as handles on each side of the UPS, respecting your hand.
- To install the device in a rack cabinet, it is necessary to have internal lateral guides for use as supports. Alternatively, and upon request, we can supply universal slides for use as guides, for installation by the user.
- Mount the guides at the required height, ensuring correct tightening of the fixing screws and appropriate fitting in the machining, according to each case.
- Place the device onto the guides and insert it all the way to the back.
- Depending on the device model and weight, and/or whether it is installed in the upper or lower part of the cabinet, it is recommended that two people carry out the installation operations.
- Fix the UPS to the cabinet frame using the screws supplied with the handles.

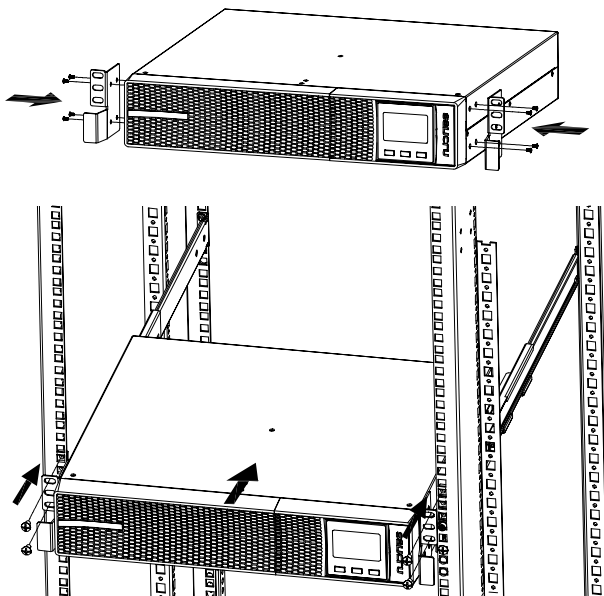

Fig. 5. Rack-type mounting in a 19" cabinet.

5.1.5.4. Preliminary considerations before connection.

Thermal control of these devices is carried out with the passage of forced air from the front to the rear.

The front surface and about 15 cm on the rear side should be left free of obstructions to facilitate the free circulation of air for ventilation.

Follow and observe the instructions provided in this section.

Protection or external manual bypass board:

- The system will have at least one short-circuit protection on the UPS's power supply line.
- It is advisable to have an external manual bypass board fitted with input, output and manual bypass protections.

Upon request, we can supply an external manual bypass board.

You can also choose to manufacture one, taking into account the version and configuration of the available device or system and the attached documentation regarding 'Recommended installation'.

Only rated currents are printed on the nameplate of the device as indicated by the EN-IEC 62040-1 safety standard. For the calculation of the input current, the power factor and the device's own performance have been considered.

Overload conditions are considered a non-permanent and exceptional working mode, and will not be taken into account in the application of the protections. Do not connect appliances or devices which may overload the UPS to the terminals and/or outlets, such as motors.

If peripheral input or output elements, such as transformers or autotransformers, are added to the UPS, the currents indicated on the nameplates of these elements must be taken into consideration when determining appropriate cross sections, in compliance with local and/or national low voltage electrotechnical regulations.

When a galvanic isolation transformer is added to a UPS as standard, as an optional extra or independently, either on the input line, at the output or both, it must be fitted with protection against indirect contact (differential circuit breaker) at the output of each transformer, since, due to its own insulation properties, it will prevent the tripping of the protections placed on the primary of the isolation transformer in case of electric shock on the secondary (output of the isolation transformer).

We remind you that all the isolation transformers installed or factory supplied, have the output neutral earthed through a jumper between the neutral terminal and earth. If the isolated output neutral is required, this jumper must be removed, taking the precautions indicated in the respective local and/or national low voltage regulations.



This device is suitable for installation in networks with TT, TN-S, TN-C or IT power distribution systems, taking into account at the time of installation the particularities of the system used and the national electrical regulations of the destination country.

The SLC TWIN RT2 LION features terminals for the installation of an external emergency power off button (EPO) or, failing that, a single device must be installed to cut the power supply to the loads in any operating mode.

5.1.5.5. Preliminary considerations before connection, regarding the batteries and their protections.

The batteries for the SLC TWIN RT2 LION models are in the same box as the devices.

⚠ VERY IMPORTANT: For safety reasons, the batteries are disconnected. Before installing the UPS, follow the steps below to reconnect them:

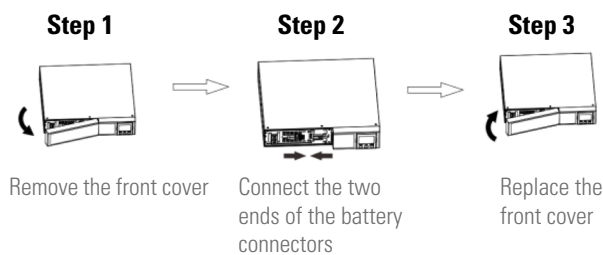

The batteries are always protected by internal fuses that are not accessible to the user.

⚠ If the mains power of the device or parallel system is cut for longer than a simple intervention and it is expected that it will be out of service for a prolonged period time, the system must be shut down completely.

5.1.5.6. Connection elements.

All of the device's electrical connections are made from the back of each unit:

- Input and output connection.
 - Input by means of a cable with plug, connectable to the UPS through an IEC connector.
 - Outputs through IEC connectors.
- Communication connectors available:
 - DB9 for RS-232.
 - USB to operate the UPS as a PC peripheral.
 - For connection to external EPO button.
 - Slot for the integration of one of the optional electronic communication units. Remove the fixing screws and plastic cover to enable it to be inserted.

5.2. CONNECTIONS.

5.2.1. Connection of the input.

- Take the power cable with plug and IEC connector on the end and insert the latter into the input connector of the UPS.
- Plug the power cable into an earthed AC power socket.

5.2.2. Connection to the IEC output connectors.

The SLC TWIN RT2 LION models have a different number of female IEC output connectors, depending on the power of the model:

- Models up to 2 kVA: Two groups of four IEC 10A connectors identified as 'OUTPUT' and 'OUTPUT PROGRAMMABLE (P1)', which can be configured via the control panel and/or ViewPower.
- 3 kVA models: same connectors as models up to 2 kVA and an additional 16A IEC connector.

⚠ Do not connect loads that in their entirety exceed the specifications of the device, as this would cause inconvenient cuts in the power supply of the loads connected to the output.

If, in addition to the more sensitive 'critical loads,' it is necessary to connect high-consumption inductive loads, such as for laser printers or CRT monitors, the starting up of these peripherals will need to be taken into account to prevent the device from crashing.

We do not recommend connecting loads of this type due to the amount of power they absorb from the UPS.

5.2.2.1. Connecting the loads.

Connect the loads to the 10 A IEC connectors.

⚠ It is important to consider the two groups of IEC connectors available, those for 'critical loads' and those for 'non-critical loads'.

By definition, 'critical loads' are considered to be those that can cause economic damage if they stop functioning or function incorrectly.

The IEC connectors indicated in Fig. 2 as 'non-critical loads' can be programmed as such through the control panel. In this case, the backup of the batteries for the loads connected to the IEC connectors indicated in Fig. 2 as 'critical loads' will be reserved. Take into account that they are set by default as 'critical loads'.

⚠ The 3 kVA models also have a 16A IEC connector that enables the connection of a load of the total power of the device.

5.2.3. Terminals for EPO (emergency power off).

The UPSs have two terminals for the installation of an external emergency power off (EPO) output button.

The device is dispatched from the factory with its EPO circuit set to closed (NC) by default. In other words, the UPS will cut the output power supply, emergency power off, when the circuit is opened:

- Either by removing the female connector from the socket where it is inserted. This connector has a cable connected as a jumper that closes the circuit (see Fig. 6- A),
- or by pressing the button external to the device belonging to the user installed between the terminals of the connector (see Fig. 6- B). The connection on the button must be in the normally closed contact (NC), so it will open the circuit when activated.

The reverse functionality can be selected via the communications software and control panel (settings menu 15).

Except for specific cases, we advise against this type of connection in view of the purpose of the EPO button, since it will not act upon an emergency request if either of the two cables that run from the button to the UPS is accidentally cut.

By contrast, this anomaly would immediately be detected in a closed EPO circuit, with the inconvenience of an unexpected cut in the powering of the loads, but a guarantee of effective emergency functionality.

To recover the normal operating state of the UPS, it is necessary to insert the connector with the jumper in its receptacle or deactivate the EPO button. The device will be operational.

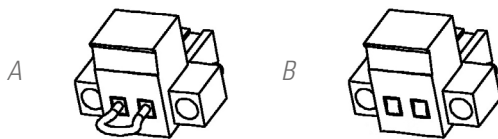

Fig. 6. Connector for external EPO.

5.2.4. Communication port.

5.2.4.1. RS-232 and USB port.



The COM communications line is a very low voltage safety circuit. To preserve the quality, it must be installed separately from other lines carrying dangerous voltages (power distribution line).

The RS-232 and USB interfaces are useful for the monitoring software and updating the firmware.

It is not possible to use both the RS-232 and USB ports at the same time.

In connector DB9, the signals of the RS-232 are supplied.

The RS-232 port consists of the transmission of serial data in such a way that a large amount of information can be sent through a communication cable with only 3 wires.

The USB port is compatible with the USB 1.1 protocol for communication software.

Pin #	Description	Input / Output
2	TXD for RS-232	Output
3	RXD for RS-232	Input
5	GND for RS-232	Earth

Tab. 3. Pinout of DB9 connector, RS-232.

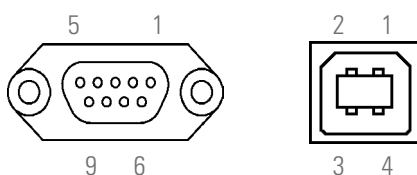

Fig. 7. DB9 connectors for RS-232 and USB.

5.2.5. Smart slot for the integration of an electronic communication unit.

Optional electronic communication units include:

- Relay interface to terminals, not programmable.
- SNMP adapter.
- RS-485 modbus adapter.

The corresponding documentation is supplied with each option. Read it before starting installation.

Installation.

- Remove the protective cover from the device's slot.
- Take the corresponding electronic unit and insert it into the reserved slot. Make sure that it is properly connected, for which it is necessary to overcome the resistance caused in the connector located in the slot.
- Make the necessary connections in the terminal block or connectors available according to each case.
- Fit the new protective cover supplied with the relay interface card and secure it with the screws from the old cover.
- For more information, contact our **T.S.S.** or our nearest distributor.

5.2.6. Protection against voltage spikes for the modem / ADSL / fax, etc., line.



The COM communications line is a very low voltage safety circuit. To preserve the quality, it must be installed separately from other lines carrying dangerous voltages (power distribution line).

- Connect the main line for the modem / ADSL / fax, etc., to the RJ45 connector of the device, identified as 'Input.'
- Connect the modem / ADSL / fax, etc., to the RJ45 connector of the device, identified as 'Output.'

5.2.7. Software.

Download of free ViewPower software.

ViewPower is a UPS monitoring software which provides a user-friendly interface for monitoring and control. It features an auto shutdown function for systems consisting of several PCs in case of power failure. The software enables users to monitor and control any UPS in the same LAN through an RS-232 or USB communications port, regardless of how far away they are from each other.

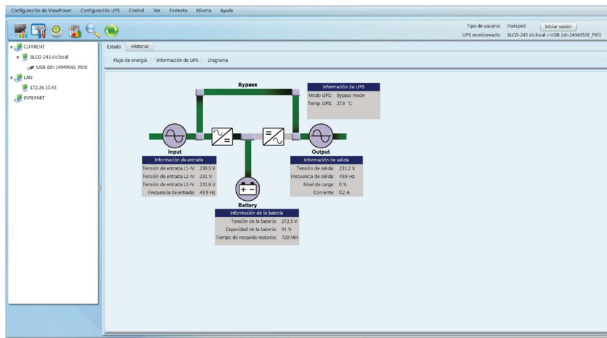

Fig. 8. View of ViewPower's main screen.

Installation procedure:

- Go to the web page:
<http://support.salicru.com>
- Select the required operating system and follow the instructions described on the web page to download the software.

5.2.8. Considerations before startup with connected loads.



We recommend charging Li-ion batteries for at least five hours before using the UPS for the first time.

For this, it will be necessary to supply voltage to the device. The battery charger will work automatically.

Although the device can operate correctly without charging the batteries for the specified 5 hours, the risk of a prolonged power cut during the first hours of operation and the UPS's available backup time should be assessed.

Do not start up the device and loads completely until indicated in Chapter 6.

When it is done, however, it should be carried out gradually to avoid possible difficulties, if not at the first startup.

If, in addition to the more sensitive loads, it is necessary to connect high-consumption inductive loads, such as for laser printers or CRT monitors, the starting up of these peripherals will need to be taken into account to prevent the device from crashing.

For this type of load considered NON-PRIORITY, a group of programmable terminals is available depending on the model. Depending on the programming of these, the power supply may or may not be affected in the event of mains failure.

6. OPERATION.

6.1. START-UP.

6.1.1. Checks before start-up.

- Make sure that all of the connections have been made correctly, following the instructions on the labelling of the device and in Chapter 5.
- Check to make sure the UPS switch is in the 'Off' position.
- Make sure that all loads are 'Off'.



Shut down the connected loads before starting the UPS and start the loads, one by one, only when the UPS is running. Before shutting down the UPS, check that all of the loads are 'Off'.

- It is very important to proceed in the established order.
- For views of the UPS, see Fig. 1 and Fig. 2.

6.2. UPS STARTUP AND SHUTDOWN.

6.2.1. UPS startup with mains voltage.

- Check that the power connection is correct.
- Supply voltage to the device (set the input protection of the distribution board or manual bypass to 'On'). If the board has an output switch, set it to 'On'.



The IEC output connectors will have voltage through the device's internal static bypass block.

The fan or fans, depending on the model, will start to function.

Then the main start screen will be displayed after a test of the device.

- Press the "ON" button for more than 2 seconds, the audible alarm will sound for 1 second and the UPS will start up.
- The UPS is set to 'Normal mode' after a few seconds. If the mains voltage is incorrect, the UPS will switch to 'Battery mode', without interrupting the power supply at the output terminals.
- Start the load or loads, making sure that the rated power of the device is not exceeded.

6.2.2. UPS startup without mains voltage.

- If it has a distribution board, set the input and output protections to 'On'.
- Press the "ON" button for more than 2 seconds, the audible alarm will sound for 1 second and the UPS will start up. The fan or fans, depending on the model, will start to function. Then the main start screen will be displayed after a test of the device.
- The UPS is set to 'Battery mode' after a few seconds. Depending on the level of charge of the batteries, the residual backup available may be very limited. Consider the risk involved in operating without mains and discharged batteries. If the mains voltage returns, the UPS will transfer to 'Normal mode' without interrupting the power supply at the output terminals.

- Start the load or loads, making sure that the rated power of the device is not exceeded.

6.2.3. UPS shutdown with mains voltage.

- Shut down the load or loads.
- Press the "OFF" button for more than 2 seconds to shut down the inverter. The audible alarm will sound for 1 second. The device will be set to 'Bypass mode'.



The output terminals will have voltage through the device's internal static bypass block.

- To cut the UPS's output voltage:
 - Remove the input plug from the power socket,
 - or simply turn the input and output protectors on the UPS's distribution board to the 'Off' position (this applies to any model).

A few seconds later, the LCD screen turns off and the entire device will be out of service.

6.2.4. UPS shutdown without mains voltage.

- Shut down the load or loads.
- Press the "OFF" button for more than 2 seconds to shut down the inverter. The audible alarm will sound for 1 second. The device will leave the output terminals without voltage. A few seconds later, the LCD screen turns off and the entire device will be out of service.
- To leave the assembly completely isolated, set the input and output switches of the board to 'Off'.

7. CONTROL PANEL WITH LCD.

7.1. GENERAL INFORMATION FOR THE SERIES.

7.1.1. Information represented by the display.

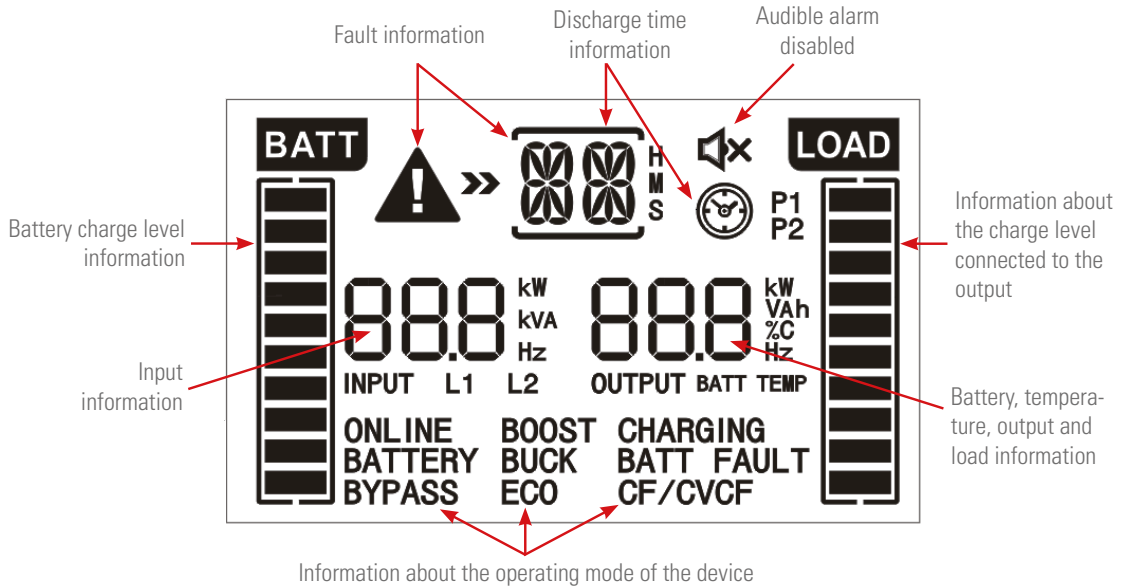

Fig. 9. Graphic and textual information shown on the display.

7.1.2. Common messages shown on the LCD display.

Display	Meaning
Backup time information.	
	Indicates the estimated backup time. H - Hours, M - Minutes, S - Seconds.
Configuration of settings and fault information.	
	Indicates a numerical code from the settings menu in relation to Tab. 9 in Section 7.5.
	Indicates a warning or fault code in accordance with Tab. 12 and Tab. 13.
Audible alarm information.	
	Indicates that the audible alarm is disabled.
Battery, temperature, output and load information.	
	Indicates the batteries' voltage, current and capacity. Ambient temperature, voltage, frequency, intensity and % of output load. V: voltage; A: current; %: percentage; °C: degrees centigrade; Hz: frequency.
Information about the charge level connected to the output.	
	Indicates the charge level connected to the output as a %, by displaying four equivalent segments respectively in the following proportion: 0-25%, 26-50%, 51-75% and 76-100%.
Information about programmable outputs	
P1	Indicates that the programmable outputs are supplying voltage.

Information about the operating mode of the device.	
BATTERY	Indicates that the device is supplying output voltage from the battery (battery mode).
BYPASS	Indicates that the device is activated in BYPASS mode.
ECO	Indicates that the device is supplying output voltage from the bypass (ECO mode).
CHARGING	Indicates that the device is in charging mode.
CF/CVCF	Indicates that the device is in converter mode.
ONLINE	Indicates that the inverter is working.
Information about battery charge level.	
	Indicates the battery charge level as a %, by displaying four equivalent segments respectively in the following proportion: 0-25%, 26-50%, 51-75% and 76-100%.
	Indicates that the battery is not connected.
	Indicates low battery voltage level.
Voltage, frequency and input intensity information.	
	Indicates the input voltage and its frequency and current. V: voltage; Hz: frequency; A: current.

Tab. 4. Information shown on the LCD panel of the control panel and its meaning.

7.1.3. Common abbreviations shown on the display.

Code	On display	Meaning
ENA	E A	Enabled.
DIS	d1S	Disabled.
ON	ON	Start-up.
OFF	OFF	Shutdown.
EPO	EP	Emergency power off.
ESC	ESC	Escape.
AO	AO	EPO normally open.
AC	AC	EPO normally closed.
EAT	EAt	Estimated backup time.
RAT	tAt	Current time in backup mode.
Ok	OK	Ok.
SD	Sd	Shutdown.
BL	bL	Battery low.
OL	OL	Overload.
OI	OI	Input overcurrent
NC	NC	Battery not connected
OC	OC	Battery overcharge
SF	SF	Connection error. Rotate the connection of the input, phase and neutral cables.
TP	TP	Overtemperature.
CH	CH	Charger
BF	bF	Battery failure, low voltage.
BV	bV	Bypass voltage out of range.
FU	FU	Bypass frequency out of range.
BR	bR	Replace batteries.
EE	EE	Internal EEPROM error.

Tab. 5. Abbreviations shown on the LCD.

7.2. CONTROL PANEL

7.2.1. Composition of the control panel with LCD display.

- The control panel consists of:
 - Three buttons with the functions described in Tab. 6.
 - An LCD with backlighting.

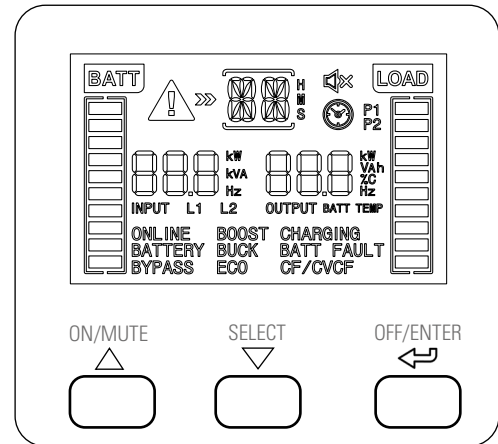

Fig. 10. View of the control panel.

Button	Description
ON/MUTE △	<p>- Starting up the UPS. Press the button for at least 2 seconds.</p> <p>- Muting the alarm. Press the button for at least 3 seconds to mute or unmute the audible alarm.</p> <p>- Button to navigate upwards. When this button is pressed in UPS settings mode, it will move upwards through the menu structure in relation to the point where it is located, accessing the previous variable with each press.</p> <p>- Activating the battery test. Press this button for 3 seconds while in normal or frequency converter (CF) mode. At the end of the test, it returns to the respective mode.</p>
SELECT ▽	<p>- LCD readings and measurements. Press this key to view readings for: input voltage, input frequency, input current, battery voltage, battery current, battery capacity, ambient temperature, output voltage, output frequency, output current and % of output load.</p> <p>- Settings or configuration mode. With the UPS's inverter stopped (Bypass mode), press this key for at least 3 seconds to access this mode.</p> <p>- Button to navigate downwards. When this button is pressed in UPS settings mode, it will move downwards through the menu structure in relation to the point where it is located, accessing the following variable with each press.</p>
OFF/ENTER ↵	<p>- UPS shutdown. Press this button for at least 2 seconds. The UPS will transfer to Standby or Bypass mode, depending on whether bypass is enabled or disabled.</p> <p>- Confirmation of selection. Press this button to confirm selection in the device's settings mode.</p>
ON/MUTE △ + SELECT ▽	<p>- Transfer to Bypass mode Pressing both keys for 3 seconds will transfer the UPS to Bypass mode, provided the input voltage is within the acceptable margins. To return to Inverter mode from this forced Bypass mode, press both keys again.</p> <p>- Exiting Settings mode From the Settings menu, press both keys in order to exit Settings mode and return to the main screen.</p>

Tab. 6. Functionality of the control panel buttons.

7.2.2. Audible alarms.

Description	Alarm modulation or tone	Possibility of muting
State of the UPS		
Bypass mode	Beep every 10 seconds.	Yes
Battery mode	Beep every 5 seconds.	
Fault	Continuous.	No
Warning		
Overload	Beep every second.	Yes
End of backup	Beep every 1 seconds.	No
Faults		
All	Continuous.	No

Tab. 7. Audible alarms.

7.2.3. Location of the setting parameters on the display.

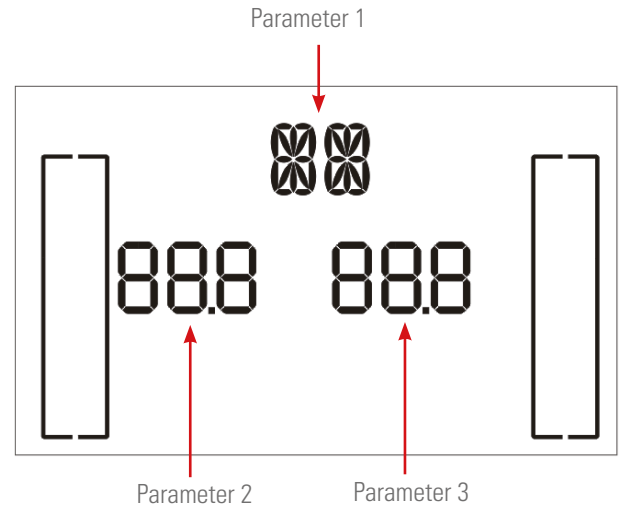

Fig. 11. Arrangement of the parameters on the LCD.

- Parameter 1:
Code of the settings menu. For more information consult Tab. 8.
- Parameters 2 and 3 are the configuration or value options for each settings menu.
 - Select with buttons '▽' or '△' to modify the menus or parameters.
 - All of the parameter settings are saved when the UPS is completely shut down and provided that it has connected batteries, whether internal or external. If a complete shutdown is not carried out, the setting will not be saved to the memory.

7.2.4. Settings.

Tab. 8 shows a summary of the adjustable codes for parameter 1, while Fig. 12 shows the structure of the menu tree with the operating mode for the settings.

Code	Description
01	Output voltage setting.
02	Activation/deactivation of frequency converter mode.
03	Output frequency setting.
04	Enable/disable ECO mode.
06	Enable/disable bypass (UPS 'Off').
09	Enable/disable programmable outputs.
10	Backup limitation configuration for programmable outputs.
11	Backup limitation configuration.
15	EPO logical configuration.
17	Viewable backup time configuration.

Tab. 8. Parameter 1 codes list.

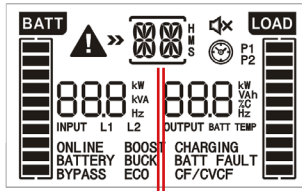

- The values indicated with(*) are factory default settings.
- The settings can only be made in 'byPA' or 'STby' mode.
- To carry out any modification of the configuration, follow the indicated sequence with the inverter necessarily Off.
- To exit the main menu from any position, press buttons ▽ + △ together.

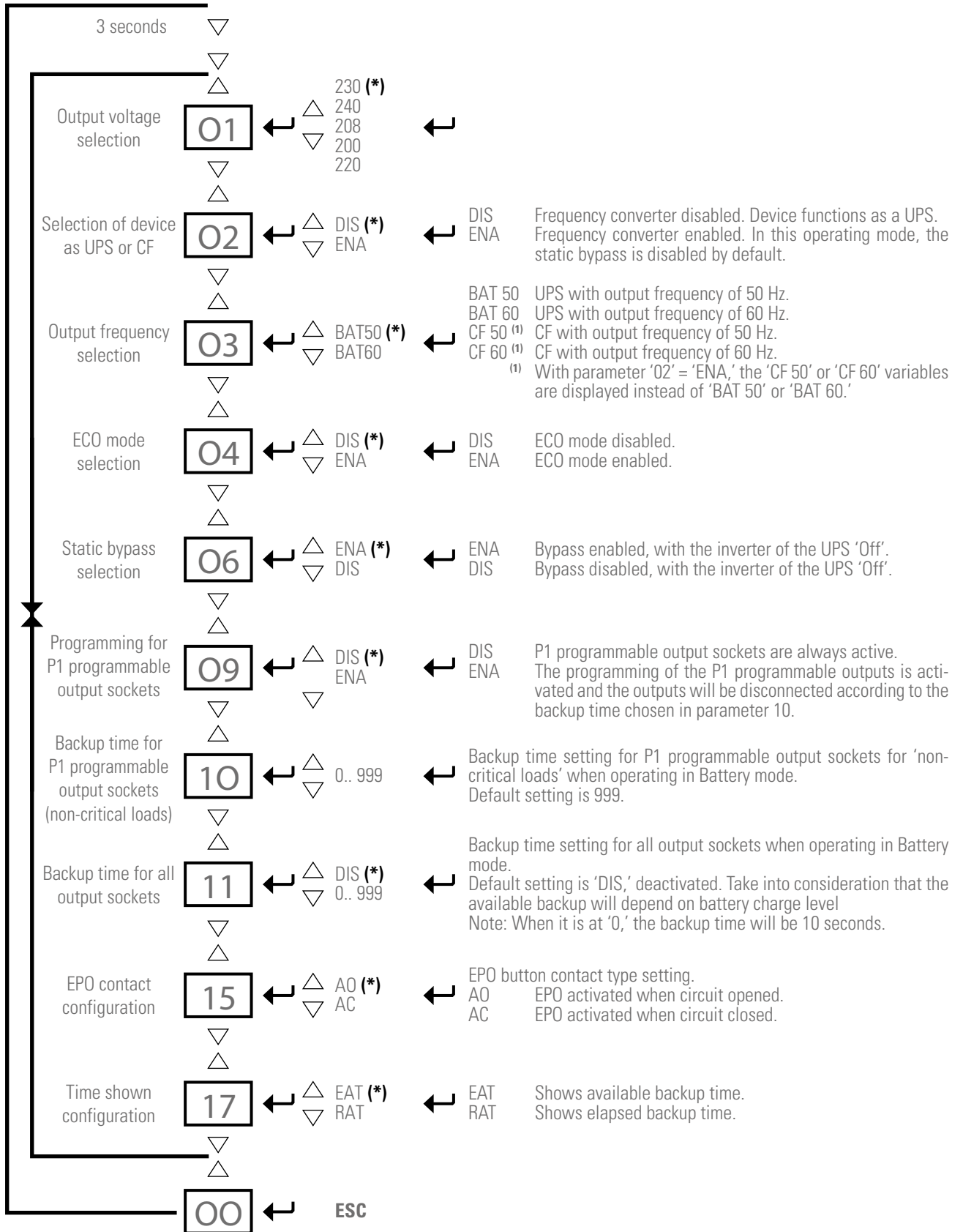
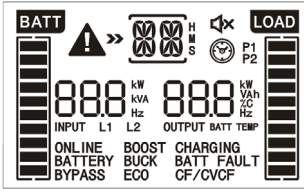
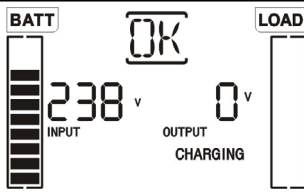
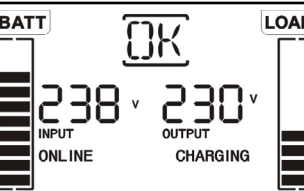

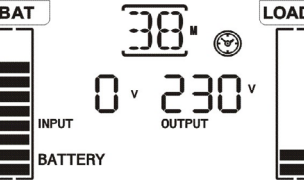
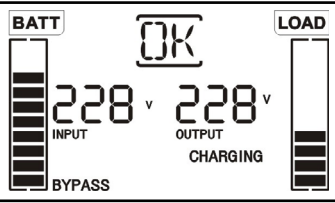
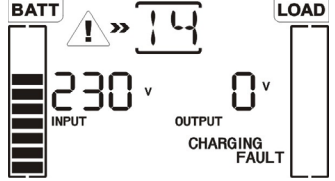

Fig. 12. Settings menu.















7.2.4.1. Operating mode / Description of state.

Operating mode / state		
	Description	When the UPS is started, the display screen of this mode is displayed for a few seconds to initialise the CPU and system.
UPS startup	LCD display	
	Description	The UPS is off and no output voltage is available, but it is charging the batteries.
No output mode	LCD display	
	Description	If the input voltage is within the range of the device, the UPS will supply stable AC sine-wave voltage to the load or loads, and charge the batteries.
AC mode	LCD display	
	Description	If the input voltage is within the regulation ranges and ECO mode is activated, the UPS supplies the output voltage from the bypass in ECO mode (energy saving).
ECO mode	LCD display	
	Description	When the input frequency is between 46 and 64 Hz, the UPS can be set to a constant output frequency of 50 or 60 Hz. The device will still charge the batteries in this mode.
CF mode	LCD display	
	Description	Description: When the input voltage/frequency is not within the predefined margins for the device, or there is an AC mains failure, the UPS will power the loads from the batteries for the amount of time permitted by the batteries' capacity and the modulated audible alarm will sound every 5 seconds.
Battery mode	LCD display	

Operating mode / state		
	Description	When the input voltage is within the margins but the UPS is overloaded, the system will automatically transfer to Bypass mode, or the transfer to this mode can be forced via the front panel. The audible alarm beeps every 10 seconds.
Bypass mode	LCD display	
	Description	When an error occurs, the ERROR icon and the fault code are displayed.
Error or fault state	LCD display	

Tab. 9. Operating modes.

7.2.4.2. Warning or alert indicators.

Description	Icon (flashing)	Code	Audible alarm
Low battery voltage.		bL	Modulated every 2 s
Overload.		OI	Modulated every 1 s
Input overcurrent		OI	Modulated twice every 10 seconds.
Battery disconnected		NC	Modulated every 2 s
Battery overcharge		OC	Modulated every 2 s
Input socket connection fault		SF	Modulated every 2 s
EPO enabled		EP	Modulated every 2 s
Overtemperature		TP	Modulated every 2 s
Charger fault.		CH	Modulated every 2 s
Battery fault		bF	Modulated every 2 s (The UPS disconnects to warn the user that the batteries are incorrect).
Static bypass voltage out of range		bV	Modulated every 2 s
Unstable static bypass frequency		FU	Modulated every 2 s
Replace batteries		bR	Modulated every 2 s
EEPROM error		EE	Modulated every 2 s

Tab. 10. Warning or alert indicators.

7.2.4.3. Error or fault codes.

Code	Error or failure description
01	DC bus startup fault.
02	DC bus overvoltage.
03	DC bus undervoltage.
11	Inverter soft start fault.
12	High voltage in the inverter.
13	Low voltage in the inverter.
14	Inverter output short-circuited.
27	Battery voltage too high
28	Battery voltage too low
2A	Battery charger short-circuited at its output.
41	Overtemperature
43	Output overloaded.
45	Charger fault.
49	Input overcurrent

Tab. 11. Error or fault codes.

8. MAINTENANCE, WARRANTY AND SERVICE.

8.1. BATTERY MAINTENANCE.

- Pay attention to all of the safety instructions concerning batteries indicated in section 1.2.3 of manual EK266*08.
- The service life of the batteries greatly depends on the ambient temperature and other factors such as the number of charges and discharges, as well as their depth. Their service life is around 10 years, if the ambient temperature to which they are exposed is between 10 and 20°C.
- The SLC TWIN RT2 LION series requires minimum upkeep. The batteries used in the standard models are maintenance-free Li-ion. The only requirement is to charge the batteries regularly to extend their life expectancy. While the UPS is connected to the mains supply, whether or not it is running, it will keep the batteries charged and also offer protection from overcharging and deep discharge.

8.2. UPS TROUBLESHOOTING GUIDE.











If the UPS is not working properly, check the information shown on the control panel's LCD screen and take the corresponding action.

Using the Tab. 12 troubleshooting guide, try to resolve the issue and, if it persists, consult our Technical Service and Support **T.S.S.**

If it is necessary to contact our Technical Service and Support **T.S.S.**, provide the following information:

- UPS model and serial number.
- Date on which the issue occurred.
- Full description of the issue, including information provided by the LCD or LEDs and state of the alarm.
- Power supply conditions, type of load and level of load applied to the UPS, ambient temperature, ventilation conditions.
- Any other information considered relevant.

8.2.1. Troubleshooting guide.

Symptom	Possible cause	Solution
No alarms or indications on the LCD and mains voltage normal.	The power cable is not connected correctly.	Check that the power cables are firmly connected to the mains.
Icon  and warning code  flash on the LCD and the audible alarm modulated every second is active.	The EPO function is activated.	Close the EPO signal circuit to deactivate it.
Icon  and warning code  flash on the LCD and the audible alarm modulated every two seconds is active.	Neutral to earth fault detection. Inverted phase and neutral input cables.	Disconnect input plug from AC power socket and invert connection of phase and supply neutral (rotate plug 180°).
Icon  and warning code  flash on the LCD and the audible alarm modulated every two seconds is active.	The internal or external batteries are badly connected.	Check that all batteries are properly connected.
Icon  and warning code  flash on the LCD display and the audible alarm modulated every two seconds is active.	The batteries have reached the end of their useful life and need to be replaced.	Contact the distributor or seller or, failing that, our T.S.S.
Fault code 27 and the BATT FAULT message are shown on the LCD. The alarm sounds continuously.	Voltage of batteries too high or charger faulty.	Contact distributor or seller or, failing that, our T.S.S.
Fault code 28 and the BATT FAULT message are shown on the LCD. The audible alarm sounds continuously.	Voltage of batteries too low or charger faulty.	Contact distributor or seller or, failing that, our T.S.S.
Icon   and warning code  flash on the LCD and the audible alarm modulated every second is active.	UPS overloaded.	Disconnect excess loads from output sockets.
	UPS overloaded. The connected loads are powered directly from the mains through the Bypass. After repeated overloads, the UPS is locked in Bypass mode. The connected loads are powered directly from the mains.	Disconnect excess loads from output sockets. Disconnect the excess loads from the output sockets, shut down the device and restart it.
Fault code 49 is shown on the LCD. The audible alarm sounds continuously.	UPS input overcurrent.	Disconnect excess loads from output sockets.
Fault code 43 is shown on the LCD. The audible alarm sounds continuously.	The UPS shuts down automatically as a result of an overload in the output of the device.	Disconnect the excess loads from the output sockets and restart it.
Fault code 14 is shown on the LCD. The audible alarm sounds continuously.	The UPS shuts down automatically as a result of a short circuit in the output.	Check the output wiring and that the connected loads are not short-circuited

Symptom	Possible cause	Solution
Fault codes 01, 02, 03, 11, 12, 13 and 41 are shown on the LCD. The audible alarm sounds continuously.	An internal fault has occurred in the UPS. This is due to one of two possibilities: 1. The load is still powered, but directly from the mains through the bypass. 2. The load is no longer powered.	Contact distributor or seller or, failing that, our T.S.S.
The backup time is shorter than expected.	The batteries do not charge completely.	Charge the batteries for at least 5 h and then check their charge state. If problem persists, contact distributor or seller or, failing that, our T.S.S.
	Faulty batteries.	Contact the distributor or seller or, failing that, our T.S.S. for battery replacement.
Fault code 2A is shown on the LCD. The audible alarm sounds continuously.	Charger short-circuited at its output.	Check whether the connection of the external battery pack connected to the UPS is short-circuited.
Fault code 45 is shown on the LCD. At the same time, the audible alarm sounds continuously.	The charger does not provide output and the battery voltage is less than 10 V per element.	Contact distributor or seller or, failing that, our T.S.S.

Tab. 12. Troubleshooting guide.

8.3. WARRANTY CONDITIONS.

8.3.1. Terms of the warranty.

On our website, you will find the warranty conditions for the product you have purchased where you can also register it. It is recommended to do so as soon as possible to include it in the database of our Technical Service and Support (**T.S.S.**). Among other advantages, it will streamline any regulatory procedures for the intervention of **T.S.S.** in the event of a fault.

8.3.2. Exclusions.

Our company will not be bound by the warranty if it notices that the defect in the product does not exist or was caused by improper use, negligence, improper installation and/or verification, attempts at unauthorised repair or modification, or any other cause beyond the intended use, or by accident, fire, lightning or other hazards. Nor shall it cover any compensation for loss or damage.

8.4. TECHNICAL SERVICES NETWORK.

Information about our national and international Technical Service and Support (**T.S.S.**) centres can be found on our website.

9. ANNEXES.

9.1. GENERAL TECHNICAL SPECIFICATIONS.

Models	TWIN RT2 LION			
Available power ratings (kVA / kW)	1000 / 900	1500 / 1350	2000 / 1800	3000 / 2700
Technology	On-line double-conversion, PFC, double DC bus			
Rectifier				
Input type	Single-phase			
Number of cables	3 cables - Phase R (L) + Neutral (N) and earth			
Rated voltage	200 / 208 / 220 / 230 / 240 V AC			
Input voltage range	160.. 300 V AC with 100% load. 110 V up to 60% load			
Frequency	50 / 60 Hz (auto-detectable)			
Input frequency range	± 10 Hz (40.. 60 / 50.. 70 Hz)			
Total harmonic distortion (THDi), at full load	≤ 5 %			
Power factor	≥ 0,99 (at full load)			
Inverter				
Technology	PWM			
Waveform	Pure sinusoidal			
Power factor	0.9			
Rated voltage	200 / 208 / 220 / 230 / 240 V AC ⁽¹⁾			
Output voltage accuracy (battery mode)	± 1 %			
Total harmonic distortion (THDv), with linear load	≤ 2%			
Frequency	With mains present, synchronised to rated input 47.. 53 Hz or 57.. 63 Hz. With mains absent -backup mode- 50 / 60 ±0.1 Hz.			
Frequency synchronous speed	< 1 Hz/s.			
Transfer time, inverter to battery	0 ms.			
Performance at full load, in line mode with battery 100% charged	> 90 %		> 91 %	> 90 %
Performance at full load, in ECO mode	> 96 %			
Overload line mode	110.. 130 %, 5 min.			
	> 130.. 140 %, 30 s.			
	> 140 %, 1.5 s.			
Overload battery mode	110.. 130 %, 1 min.			
	> 130.. 140 %, 2 s.			
	> 140 %, 1.5 s.			
Crest factor	3:1			
Static bypass				
Type	Common line with mains. Mixed (thyristors in antiparallel + relay)			
Rated voltage	That of the mains			
Rated frequency	That of the mains			
Batteries				
Type	LiFePO4			
Model (amount)	LiFe-247500 (x1)	LiFe-48500 (x1)	LiFe-48500 (x2 in parallel)	LiFe-722500 (x3 in parallel)
Battery voltage / capacity	25.6V / 7.5 Ah		48V / 5 Ah	76.8V / 2.5 Ah
Total capacity, group	7.5 Ah	5 Ah	10 Ah	7.5 Ah
Blocking voltage for group end of backup	21.2 V DC		39.8 V DC	63.6 V DC
Internal battery charger				
Charger voltage	28.0 V DC		52.5 V DC	84.0 V DC
Load current	1/2/4/6/8 A (4 A by default)			
Recharge time	2 hours @ 4A			
Other functions				
Cold start	Yes			
Emergency power off	Yes			
Frequency converter	Yes ⁽²⁾			
General				
IEC input connectors	10A IEC connector		16A IEC connector	
Output IEC connectors	8 IEC 10A (4 + 4)			8 IEC 10A (4 + 4) + 1 IEC 16A
Communication ports	2 (DB9 RS-232 and USB, mutually exclusive)			
ADSL/fax/modem transient protector	Yes (RJ45 connectors)			
Monitoring software	ViewPower (free download)			
Optional cards (to insert in slot)	Relay interface, SNMP, remote Internet or intranet management			

Models	TWIN RT2 LION			
	1000 / 900	1500 / 1350	2000 / 1800	3000 / 2700
Available power ratings (kVA / kW)				
Noise level at 1 m.	<50 dB			
Operating temperature	0.. + 40°C			
Storage temperature	-15.. + 50°C			
Operating altitude	2,400 masl (power degradation up to 5,000 m)			
Relative humidity	0-95% non-condensing.			
Protection rating	IP20			
Dimensions (mm.) (Depth × Width × Height)	410 x 438 x 88		510 x 438 x 88	630 x 438 x 88
Module height in number of U.	2			
Weight (kg.)	10.8	11.6	15.2	20.5
Safety	EN-IEC 62040-1			
Electromagnetic compatibility (EMC)	EN-IEC 62040-2 (C2)			
Operation	EN-IEC 62040-3			
Marking	EC			
Quality system	ISO 9001 and ISO 140001			

⁽¹⁾ 90% power reduction for 200 or 208 V devices.

⁽²⁾ As a frequency converter, the power supplied will be 70 % of the rated.

Tab. 13. General technical specifications.

9.2. GLOSSARY.

- **AC.** Alternating current is electric current in which the magnitude and direction vary cyclically. The waveform of the most commonly used alternating current is that of a sine wave, since this achieves a more efficient transmission of energy. In certain applications, however, other periodic waveforms are used, such as triangular or square.
- **Bypass.** Manual or automatic, this is the physical connection between the input of an electrical device and its output.
- **DC.** Direct current is the continuous flow of electrons through a conductor between two points with different potential. Unlike AC, in DC, electrical loads always circulate in the same direction from the point of greatest potential to the lowest. Although DC is commonly identified as a continuous current (for example, that supplied by a battery), any current that always maintains the same polarity is continuous.
- **DSP.** Digital signal processor. A DSP is a processor or microprocessor-based system that has a set of instructions, hardware and optimised software for applications that require numerical operations at very high speed. Because of this, it is especially useful for the processing and representation of analogue signals in real time: in a system that works in this way (real time) samples are usually received from an analogue/digital converter (ADC).
- **Power factor.** The power factor, PF, of an AC circuit is defined as the ratio between active power, P, and apparent power, S, or as the cosine of the angle formed by the current and voltage factors, designated in this case as $\cos \phi$, where ϕ is the value of the angle.
- **GND.** This stands for GROUND or EARTH and, as the name indicates, refers to the potential of the surface of the Earth.
- **EMI filter.** Filter capable of significantly reducing electromagnetic interference (EMI), which is the disturbance that occurs in a radio receiver or in any other electrical circuit caused by electromagnetic radiation coming from an external source. Electromagnetic interference is also known as radio frequency interference (RFI). This disturbance can interrupt, degrade or limit the performance of the circuit.
- **IGBT.-** An insulated gate bipolar transistor is a semiconductor device that is generally used as a controlled switch in power electronics circuits. This device possesses the characteristics of the gate signals of field effect transistors with the capacity for high current and low saturation voltage of the bipolar transistor, combining an isolated FET gate for input and control and a bipolar transistor as a single switch in a single device. The IGBT's excitation circuit is similar to that of the MOSFET, while the conducting characteristics are similar to those of the BJT.
- **Interface.** In electronics, telecommunications and hardware, an interface (electronics) is the port (physical circuit) through which signals are sent or received from one system or subsystem to another.
- **kVA.** A volt-ampere is the unit used for apparent power in electrical current. In DC, it is practically equal to real power but, in AC, it can differ from this depending on the power factor.
- **LCD.** Liquid crystal display, a device invented by Jack Jan-ning, who was an employee of NCR. It is an electrical system for data presentation formed by 2 transparent conductive layers and a special crystalline material in the middle (liquid crystal) which have the ability to orientate light as it passes through.
- **LED.** Light-emitting diode, a semiconductor device (diode) that emits light that is almost monochromatic, that is to say, it has a very narrow spectrum when it is polarised directly and is penetrated by an electric current. The colour (wave-length) depends on the semiconductor material used in the construction of the diode, and can vary from ultraviolet, passing through the visible light spectrum, to infrared, the latter called IRED (infra-red emitting diode).
- **Circuit breaker.** A circuit breaker is a device capable of interrupting the electrical current of a circuit when it exceeds certain maximum values.
- **On-line mode.** A device is said to be on-line when it is connected to a system, is operative, and normally has its

power supply connected.

- **Inverter.** An inverter is a circuit used to convert DC into AC. The function of an inverter is to change a DC input voltage to a symmetrical AC output voltage, with the magnitude and frequency desired by the user or designer.
- **Rectifier.** In electronics, a rectifier is the element or circuit that converts AC into DC. This is done by using rectifier diodes, whether solid state semiconductors, vacuum valves or gaseous valves, such as those containing mercury vapour. Depending on the characteristics of the AC power that they use, they are classified as single-phase when they are powered by a mains phase or three-phase when they are powered by three phases. Depending on the type of rectification, they can be half wave when only one of the half cycles of the current is used or full wave when both half cycles are used.
- **Relay.** A relay is an electromechanical device that functions as a switch controlled by an electrical circuit in which, by means of an electromagnet, a set of one or several contacts is activated to enable other independent electrical circuits to be opened or closed.
- **SCR.** Silicon controlled rectifier, commonly known as a thyristor, a 4-layer semiconductor device that works as an almost ideal switch.
- **THD.** Total harmonic distortion. Harmonic distortion occurs when the output signal of a system does not equal the signal that entered it. This lack of linearity affects the waveform because the device has introduced harmonics that were not in the input signal. Since they are harmonic, that is to say, multiples of the input signal, this distortion is not so dissonant and is less easy to detect.

 :

A series of horizontal dotted lines for writing, starting from the first line below the scribble and extending to the bottom of the page.

SALICRU

Avda. de la Serra 100

08460 Palautordera

BARCELONA

Tel. +34 93 848 24 00

sst@salicru.com

SALICRU.COM



Information about the technical support and service network (TSS), the sales network and the warranty is available on our website:

Product range

Uninterruptible Power Supplies (UPS)

Power supplies

Variable frequency drives

Static inverters

Photovoltaic inverters

Voltage stabilisers



@salicru_SA



www.linkedin.com/company/salicru

SALICRU

