



Test Report issued under the responsibility of:



TEST REPORT
IEC 62040-1
Uninterruptible power systems (UPS) –
Part 1: General and safety requirements for UPS

Report Number..... : 2221/0040

Date of issue..... : 05/05/2022

Total number of pages : 114

Name of Testing Laboratory preparing the Report : **SGS Tecnos, S.A.U. (Electric Test Laboratory)**

Applicant's name : **SALICRU S.A.**

Address..... : **Avda de la Serra, 100
08460-Palautordera, Barcelona (Spain)**

Test specification:

Standard : IEC 62040-1:2017

Test procedure : CB Scheme

Non-standard test method : N/A

Test Report Form No. : IEC 62040_1E

Test Report Form(s) Originator : TÜV Rheinland Japan Ltd.

Master TRF : Dated 2017-11-10

Copyright © 2017 IEC System of Conformity Assessment Schemes for Electrotechnical Equipment and Components (IECEE System). All rights reserved.

This publication may be reproduced in whole or in part for non-commercial purposes as long as the IECEE is acknowledged as copyright owner and source of the material. IECEE takes no responsibility for and will not assume liability for damages resulting from the reader's interpretation of the reproduced material due to its placement and context.

If this Test Report Form is used by non-IECEE members, the IECEE/IEC logo and the reference to the CB Scheme procedure shall be removed.

This report is not valid as a CB Test Report unless signed by an approved CB Testing Laboratory and appended to a CB Test Certificate issued by an NCB in accordance with IECEE 02.

General disclaimer:







The test results presented in this report relate only to the object tested.

This report shall not be reproduced, except in full, without the written approval of the Issuing CB Testing Laboratory. The authenticity of this Test Report and its contents can be verified by contacting the NCB, responsible for this Test Report.

This document is issued by the Company under its General Conditions of service accessible at http://www.sgs.com/terms_and_conditions.htm. Attention is drawn to the limitation of liability, indemnification and jurisdiction issues defined therein. Any holder of this document is advised that information contained hereon reflects the Company's findings at the time of its intervention only and within the limits of Client's instructions, if any. The Company's sole responsibility is to its Client and this document does not exonerate parties to a transaction from exercising all their rights and obligations under the transaction documents.

Any unauthorized alteration, forgery or falsification of the content or appearance of this document is unlawful and offenders may be prosecuted to the fullest extent of the law.

Unless otherwise stated the results shown in this test report refer only to the sample(s) tested as received. Information of derived or extension models of the range as provided by the applicant, (if any), is included in this report only for informative purposes. The Company SGS shall not be liable for any incorrect results arising from unclear, erroneous, incomplete, misleading or false information provided by Client. This document cannot be reproduced except in full, without prior approval of the Company.

Test item description :	Uninterruptible power system	
Trade Mark :	SALICRU	
Manufacturer	SALICRU, S.A.	
Model/Type reference :	SLC-40-CUBE4 (See “general product information” for derived models)	
Ratings :	Input: 380/400/415 V; 83/79/76 A; 50/60 Hz; 3 + N Ph Output: 380/400/415 V; 64/61/59 A; 50/60 Hz; 3 + N Ph; 40000 VA; 40000 W (See “general product information” for derived models)	
Responsible Testing Laboratory (as applicable), testing procedure and testing location(s):		
<input checked="" type="checkbox"/>	CB Testing Laboratory:	SGS Tecnos, S.A.U. (Electric Test Laboratory)
Testing location/ address :		C/ Trespaderne, 29 – Edificio Barajas 1 28042 – Madrid (Spain)
Tested by (name, function, signature) :		Sergio San Juan (Project Engineer) 
Approved by (name, function, signature) :		Miguel Rodriguez (Technical Reviewer)  
<input checked="" type="checkbox"/>	Testing procedure: CTF Stage 1:	SALICRU, S.A.
Testing location/ address :		Avda de la Serra, 100 08460-Palautordera, Barcelona (Spain)
Tested by (name, function, signature) :		Sergio San Juan (Project Engineer) 
Approved by (name, function, signature) :		Miguel Rodriguez (Technical Reviewer)  
<input type="checkbox"/>	Testing procedure: CTF Stage 2:	N/A
<input type="checkbox"/>	Testing procedure: CTF Stage 3:	N/A
<input type="checkbox"/>	Testing procedure: CTF Stage 4:	N/A

List of Attachments (including a total number of pages in each attachment):		
Document No.	Documents included / attached to this report (description)	Page Numbers
1	Electrical diagram	5
2	Photograph annex	7
3	Test equipment list	1

Summary of testing:	
<p>Tests performed (name of test and test clause):</p> <p>The equipment SLC-40-CUBE4 has been tested according to standards:</p> <p style="padding-left: 40px;">-IEC 62040-1:2017</p> <p>All applicable tests according to the above specified standards have been carried out.</p> <p>The equipment SLC-80-CUBE4 has been partially tested according above standard: clause 5.2.3.10</p> <p>The other models indicated in “general product information” have been documentally checked. No additional tests were considered necessary.</p> <p>From the result of inspection and tests performed on the submitted sample we conclude that it complies with the requirements of the Standards.</p>	<p>Testing location:</p> <p>SGS Tecnos, S.A.U. (Electric Test Laboratory) C/ Trespaderne, 29 - Edificio Barajas 1 28042 – MADRID (Spain)</p> <p>All clauses except: 5.2.4.4, 5.2.4.5, 5.2.4.6, 5.2.4.8, 5.2.4.9, 5.2.3.8, 5.2.3.10, 5.2.3.11.2, 5.2.3.101.3, 5.2.3.102 & 5.2.3.105.2</p> <p>SALICRU S.A. Avda de la Serra, 100 08460-Palautordera, Barcelona (Spain)</p> <p>Clauses: 5.2.4.4, 5.2.4.5, 5.2.4.6, 5.2.4.8, 5.2.4.9, 5.2.3.8, 5.2.3.10, 5.2.3.11.2, 5.2.3.101.3, 5.2.3.102 & 5.2.3.105.2</p>

Summary of compliance with National Differences (List of countries addressed):
<p>EU Group Differences (No specific countries addressed).</p> <p><input checked="" type="checkbox"/> The product fulfils the requirements of:</p> <p style="padding-left: 40px;">- UNE- EN 62040-1:2019</p> <p>Official edition in Spanish language of European Standards:</p> <p style="padding-left: 40px;">- EN IEC 62040-1:2019</p>

Copy of marking plate:

The artwork below may be only a draft. The use of certification marks on a product must be authorized by the respective NCBs that own these marks.

SALICRU		
www.salicru.com		
SALICRU S.A. Telf(+34) 938 482 400		
Avda de la Serra, 100, 08460 Palautordera-Barcelona-(Spain)		
Cod. 6B3AC000003		No. 0000454463
Mod. SLC-40-CUBE4		
INPUT	380 / 400 / 415 V	3+N Ph
	83 / 79 / 76 A	50/60 Hz
OUTPUT	380 / 400 / 415 V	3+N Ph
	61 / 58 / 56 A	50/60 Hz
40000 VA	40000 W	
2A2		Icc: 6 kA

Test item particulars.....:	
Classification of installation and use.....:	<input type="checkbox"/> Ordinary Person <input type="checkbox"/> Instructed Person <input checked="" type="checkbox"/> Skilled Person
Supply Connection	<input type="checkbox"/> pluggable equipment <input type="checkbox"/> type A <input type="checkbox"/> type B <input checked="" type="checkbox"/> permanent connection <input type="checkbox"/> detachable power supply cord <input type="checkbox"/> non-detachable power supply cord
Environmental category	<input checked="" type="checkbox"/> indoor <input type="checkbox"/> unconditional <input type="checkbox"/> conditional <input type="checkbox"/> outdoor
Equipment mobility	<input type="checkbox"/> movable <input checked="" type="checkbox"/> stationary <input type="checkbox"/> for building-in <input type="checkbox"/> fixed
Access location.....:	<input checked="" type="checkbox"/> ordinary person accessible <input type="checkbox"/> restricted access location
Over voltage category	<input type="checkbox"/> OVC I <input checked="" type="checkbox"/> OVC II <input type="checkbox"/> OVC III <input type="checkbox"/> OVC IV
Mains supply tolerance (%).....:	+/- 15%
Tested for power systems	TT, TN and IT
IT testing, phase-phase voltage (V).....	380/400/415
Class of equipment.....	<input checked="" type="checkbox"/> Class I <input type="checkbox"/> Class II <input type="checkbox"/> Class III
Considered current rating of protective device as part of the building installation (A).....	N/A
Pollution degree (PD)	<input type="checkbox"/> PD1 <input checked="" type="checkbox"/> PD2 <input type="checkbox"/> PD3
IP protection class.....	IP20
Elevation during operation (m)	2400 m
Elevation of test laboratory (m)	582
Mass of equipment (kg)	290
Possible test case verdicts:	
- test case does not apply to the test object.....:	N/A
- test object does meet the requirement.....:	P (Pass)
- test object does not meet the requirement.....:	F (Fail)
Testing.....:	
Date of receipt of test item	22/06/2021
Date (s) of performance of tests	15/07/2021 to 13/12/2021
General remarks:	
"(See Enclosure #)" refers to additional information appended to the report. "(See appended table)" refers to a table appended to the report.	
Throughout this report a <input checked="" type="checkbox"/> comma / <input type="checkbox"/> point is used as the decimal separator.	

Manufacturer's Declaration per sub-clause 4.2.5 of IEC60335-1:	
The application for obtaining a CB Test Certificate includes more than one factory location and a declaration from the Manufacturer stating that the sample(s) submitted for evaluation is (are) representative of the products from each factory has been provided	<input type="checkbox"/> Yes <input checked="" type="checkbox"/> Not applicable
When differences exist; they shall be identified in the General product information section.	
Name and address of factory (ies) : SALICRU, S.A. Avda de la Serra, 100 08460-Palautordera, Barcelona (Spain)	

General product information and other remarks:

EUT is an Uninterruptible Power Supplies (UPS), the batteries are included in the same cabinet. It has double conversion technology with three-level topology. The range of equipment from 30 to 80 kVA.

MODEL		SLC CUBE 4
TECHNOLOGY		On-line, double conversion, HF, DSP control
INPUT	Rated Voltage	Three-phase 3 x380 / 3x400 / 3x415V (F-N)
	Voltage range	115-265 V (F-N)
	Rated frequency	50/60 Hz
	Frequency range	46-64 Hz
	Total harmonic distortion (THDi)	<3%
	Power factor	1 from 10% load
	Rectifier topology	Three-phase IGBT full wave, soft start, PFC, transformerless
OUTPUT	Power factor	1
	Rated voltage	Three-phase 3 x380 / 3x400 / 3x415V (F-N)
	Dynamic accuracy	±2%
	Static accuracy	±1%
	Frequency	50/60 Hz
	Total performance in On-line mode	>96%
	Performance in Smart Eco-mode	>99%
	Admissible overloads	125% for 10 min / 150% for 60s / >150% for 20ms
	Crest factor	3:1
MANUAL BYPAS	Type	Uninterrupted
STATIC BYPASS	Type and activation criteria	Solid state
	Transfer times in Smart-Eco-mode	<10ms
	Transfer to bypass	Immediate, for overloads exceeding 150%
	Retransfer	Automatic, after alarm deactivation
BATTERY	Battery type	PB-Ca, VRLA, lead acid, gel, Ni-Cd, Li-Ion
	Charging voltage regulation	Batt-Watch
COMMUNICATION	Ports	1x RS232/RS485 + 1xUSB
	Relay interface	4 relays (programmables)
	Intelligent slot	1, for SNMP/NIMBUS and relays
	Backlit LCD display	5" colour touch screen
GENERAL	Operating temperature	0°C – 40°C
	Relative humidity	Up to 95%, non-condensing
	Maximum altitude	2400 masl
	Acoustic noise at 1 metre	30-40kVA: <54dB / 50-80 KVA: <62dB

MODEL	CODE	POWER (VA / W)	DIMENSIONS (D × W × H mm)	WEIGHT (Kg)
SLC-30-CUBE4	6B3AC000001	30.000 / 30.000	910 × 380 × 1045	220
SLC-40-CUBE4	6B3AC000003	40.000 / 40.000	910 × 380 × 1045	312
SLC-50-CUBE4	6B3AD000002	50.000 / 50.000	920 × 560 × 1655	450
SLC-60-CUBE4	6B3AD000003	60.000 / 60.000	920 × 560 × 1655	450
SLC-80-CUBE4	6B3AD000001	80.000 / 80.000	920 × 560 × 1655	547

The 30kVA and 40kVA units have the same enclosure. Only difference between models are some components that change to adapt to power level. Components that change are IGBTs, thyristors, input fuse, circuit breaker and terminal blocks.

The 50kVA, 60kVA, 80kVA units have a second enclosure model. The 50kVA and 60kVA have two power modules of 30kVA, and the 80kVA has two power modules of 40kVA.

The 80kVA also has an input switch and fuse for protection instead of circuit breaker protection.

After review, the models SLC-40-CUBE4 and SLC-80-CUBE4 were tested and reported as indicated on "Summary of testing".

IEC 62040-1			
Clause	Requirement + Test	Result - Remark	Verdict
4	Protection against hazards		P
4.1/RD	General		P
4.2 4.2/RD	Fault and abnormal conditions	See Table 4.2/RD to 4.3/RD	P
5.2.4.6/RD	Breakdown of components test (type test)		P
5.2.4.6.1 /RD	Load conditions		P
5.2.4.6.2 /RD	Application of short circuit or open-circuit		P
5.2.4.6.3 /RD	Test sequence		P
4.3	Short-circuit and overload protection	See Table 4.2/RD to 4.3/RD	P
4.3.1/RD	General		P
4.3.2/RD	Specification of input short-circuit withstand strength and output short circuit current ability		P
4.3.2.1/RD	General		P
	The interrupting capability of the overcurrent protective device shall be equal or greater than the prospective short circuit current of the mains supply.		P
	For pluggable equipment type A, either the PECS shall be designed so that the building installation provides short circuit backup protection, or additional short circuit backup protection shall be provided as part of the equipment.	<i>Connection to mains through terminals. Cable or plug not provided.</i>	N/A
	For permanently connected equipment or pluggable equipment type B, it is permitted for short circuit backup protection to be in the building installation.		P
4.3.2.2/RD	Input ports short-circuit withstand strength		P
	For co-ordination and selection of internal or external protective devices, the PECS manufacturer shall specify: - a maximum allowable prospective short circuit current for each input port of the PECS; and -a minimum required prospective short circuit current in order to ensure proper operation of the protective device.		P
	If external protective devices are specified or provided the characteristics of those shall be specified by the manufacturer.	<i>Internal protective device</i>	N/A
4.3.2.3/RD	Output short circuit current ability		P

IEC 62040-1			
Clause	Requirement + Test	Result - Remark	Verdict
	<p>The output short circuit current ratings apply to a.c. and d.c. power output ports and to other ports for which overcurrent protection is necessary.</p> <p>For all output ports, short circuit evaluation to determine the minimum and maximum output short circuit current shall be performed according to 5.2.4.4/RD and the output short circuit current available from the PECS shall be specified as in 5.2.4.4/RD and 6.2.</p> <p>Internal electronic output short circuit protection is considered acceptable as an output short circuit protection device of the PECS, when compliance is shown by test in 5.2.4.4/RD.</p>		P
4.3.2.4/RD	Combined input and output ports		N/A
	For ports which are both input and output ports the applicable requirements of both 4.3.2.1/RD and 4.3.2.3/RD apply.	<i>No such parts</i>	N/A
4.3.3/RD	Short-circuit coordination (backup protection)		P
	<p>Protective devices provided or specified shall have adequate breaking capability to interrupt the maximum prospective short circuit current specified for the port to which they are connected.</p> <p>If internal protection of the PECS is not rated for the prospective short circuit current, the installation instructions shall specify an upstream protective device, rated for this prospective short circuit current of that port, which shall be used to provide backup protection. Analysis shall ensure the protection coordination between the external and internal protective device.</p>		P
	Compliance shall be checked by inspection and by the tests of 5.2.4.4/RD and 5.2.4.5/RD.		P
4.3.4/RD	Protection by several devices		P
	<p>Where protective devices that require manual replacement or resetting are used in more than one pole of a supply to a given load, those devices shall be located together. It is permitted to combine two or more protective devices in one component.</p> <p>Compliance shall be checked by inspection.</p>	<i>Unique protective device for each circuit</i>	P
4.3.101	AC input current		P
4.3.102	Transformer protection		P
4.3.103	AC input short-circuit current	<i>lcc marked on marking plate</i>	P
4.3.104	Protection of the energy storage device		P
4.3.105	Unsynchronized load transfer		P
4.4	Protection against electric shock		P

IEC 62040-1			
Clause	Requirement + Test	Result - Remark	Verdict
4.4.1/RD	General		P
4.4.2/RD	Decisive voltage class		P
4.4.2.1/RD	General		P
4.4.2.2/RD	Determination of decisive voltage class		P
4.4.2.2.1/RD	General		P
	For protection against the ventricular fibrillation body reaction, DVC can be selected from Table 2.		P
4.4.2.2.2 4.4.2.2.2/RD	Selection tables for contact area and skin humidity condition		P
4.4.2.2.3/RD	Limits of the working voltage for the DVC		P
4.4.2.3/RD	Requirements for protection against electric shock		P
4.4.3/RD	Provision for basic protection		P
4.4.3.1/RD	General		P
4.4.3.2/RD	Protection by means of basic insulation of live parts		P
	Live parts shall be completely surrounded with insulation if their working voltage is greater than DVC As or if they do not have protective separation from adjacent circuits of DVC C.		P
	Basic insulation may be provided by solid insulation or air clearance.		P
	The insulation shall be rated according to the impulse voltage, temporary overvoltage or working voltage (see 4.4.7.2.1/RD), whichever gives the most severe requirement. It shall not be possible to remove the insulation without the use of a tool or key.		P
4.4.3.3	Openings		P
4.4.3.4/RD	Protection by means of limitation of touch current and charge	<i>Equipment according clause 4.4.4.3.3.</i>	N/A
	The limitation of touch current and discharge energy shall not exceed: <ul style="list-style-type: none"> - a value of 3,5 mA a.c. or 10 mA d.c. for the limitation of touch current; and - a value of 50 µC for the limitation of discharge energy. 		N/A
4.4.3.5/RD	Protection by means of limited voltage		P
	The voltage between simultaneously accessible parts shall not be greater than DVC As as determined in 4.4.2.2/RD.		P

IEC 62040-1			
Clause	Requirement + Test	Result - Remark	Verdict
4.4.4/RD	Provision for fault protection		P
4.4.4.1/RD	General		P
	<p>Fault protection shall be provided by one or more of the following measures:</p> <ul style="list-style-type: none"> • Protective equipotential bonding in 4.4.4.2/RD in combinations with the PE conductor in 4.4.4.3/RD; • Automatic disconnection of supply in 4.4.4.4/RD; • Supplementary insulation in 4.4.4.5/RD; • Simple separation between circuits in 4.4.4.6/RD; • Electrically protective screening in 4.4.4.7/RD. <p>Fault protection shall be independent and additional to those for basic protection.</p>		P
4.4.4.2/RD	Protective equipotential bonding		P
4.4.4.2.1/RD	General		P
	<p>Protective equipotential bonding shall be provided between accessible conductive parts of the equipment and the means of connection for the PC conductor, except:</p> <ul style="list-style-type: none"> a) accessible conductive parts that are protected by one of the measures in 4.4.6.4/RD; or b) when accessible conductive parts are separated from live parts using double or reinforced insulation. 		P
	<p>Electrical contact to the means of connection of the PE conductor shall be achieved by one or more of the following means:</p> <ul style="list-style-type: none"> • through direct metallic contact; • through other accessible conductive parts or other metallic components which are not removed when the PECS is used as intended; • through a dedicated protective equipotential bonding conductor. 		P
4.4.4.2.2/RD	Rating of protective equipotential bonding		P

IEC 62040-1			
Clause	Requirement + Test	Result - Remark	Verdict
	<p>Protective equipotential bonding shall either be:</p> <p>a) sized in accordance with the requirements for the PE conductor in 4.4.4.3/RD and the means of connection for the PE conductor in 4.4.4.3.2/RD to ensure no voltage drop exceeding the values from 4.4.2.2.3/RD during a fault; or</p> <p>b) sized</p> <ul style="list-style-type: none"> • to withstand the highest stresses that can occur to the PECS item(s) concerned when they are subjected to a fault connecting to accessible conductive parts; and • to remain effective for as long as a fault to the accessible conductive parts persists or until an upstream protective device removes power from the part; and • to ensure no voltage drop exceeding the values from 4.4.2.2.3/RD during normal operation and during a fault. <p>Compliance shall be checked with the type tests in 5.2.3.11/RD</p>		P
4.4.4.3/RD	PE conductor		P
4.4.4.3.1 /RD	General		P
	<p>A PE conductor shall be connected at all times when power is supplied to the PECS, unless the PECS complies with the requirements of protective class II (see 4.4.6.3/RD) or protective class III. Unless local wiring regulations state otherwise, the PE conductor cross-sectional area shall be determined from Table 7 or by calculation according to 543.1 of IEC 60364-5-54:2011.</p>		P
	<p>If the PE conductor is routed through a plug and socket, or similar means of disconnection, it shall not be possible to disconnect it unless power is simultaneously removed from the part to be protected.</p>		N/A
	<p>The cross-sectional area of every PE conductor that does not form part of the supply cable or cable enclosure shall, in any case, be not less than:</p> <ul style="list-style-type: none"> • 2,5 mm² if mechanical protection is provided; or • 4 mm² if mechanical protection is not provided. 		P
	<p>Provisions within cord-connected equipment shall be made so that the PE conductor in the cord shall, in the case of failure of the strain-relief mechanism, be the last conductor to be interrupted.</p> <p>For special system topologies, the PECS designer shall verify the PE conductor cross-section required.</p>		P

IEC 62040-1			
Clause	Requirement + Test	Result - Remark	Verdict
4.4.4.3.2 /RD	Means of connection for the PE conductor		P
	<p>PECS shall have a means of connection for the PE conductor, located near the terminals for the respective live conductors. The means of connection shall be corrosion-resistant and shall be suitable for the connection of conductors according to Table 7 and of cables in accordance with the wiring rules applicable at the installation. The means of connection for the PE conductor shall not be used as a part of the mechanical assembly of the equipment or for other connections. Connection and bonding points shall be designed so that their current-carrying capacity is not impaired by mechanical, chemical, or electrochemical influences. Where enclosures and/or conductors of aluminium or aluminium alloys are used, particular attention should be given to the problems of electrolytic corrosion.</p> <p>Compliance shall be checked by inspection.</p>		P
4.4.4.3.3 /RD	Touch current in case of failure of PE conductor		P
	<p>For all other PECS, one or more of the following measures shall be applied, unless the touch current can be shown to be less than the limits specified in 4.4.3.4:</p> <p>a) Use of a fixed connection and</p> <ul style="list-style-type: none"> • a cross-section of the PE conductor of at least 10 mm² Cu or 16 mm² Al; or • automatic disconnection of the supply in case of discontinuity of the PE conductor; or • provision of an additional terminal for a second PE conductor of the same cross-sectional area as the original PE conductor; <p>or</p> <p>b) Use of a pluggable type B connection with a minimum PE conductor cross-section of 2,5 mm² as part of a multi-conductor power cable. Adequate strain relief shall be provided.</p>		P
	Compliance is checked by inspection and by test of 5.2.3.7/RD.		N/A
4.4.4.4/RD	Automatic disconnection of supply		N/A

IEC 62040-1			
Clause	Requirement + Test	Result - Remark	Verdict
	<p>For automatic disconnection of supply:</p> <ul style="list-style-type: none"> • a protective equipotential bonding system shall be provided; and • a protective device operated by the fault current shall disconnect one or more of the line conductors supplying the equipment, system or installation, in case of a failure of basic insulation. <p>The protective device shall interrupt the fault current within a time as specified in Figure 1, Figure 2 or Figure 3 in 4.4.2.2.3/RD.</p>		N/A
4.4.4.5/RD	Supplementary insulation		N/A
4.4.4.6/RD	Simple separation between circuits		N/A
	<p>If any component is connected between the separated circuits, that component shall withstand the electric stresses specified for the insulation which it bridges.</p> <p>If any component is connected between a circuit and a circuit connected to earth, its impedance shall limit the current flow through the component to the steady-state touch current values indicated in 4.4.3.4/RD.</p>		N/A
4.4.4.7/RD	Electrically protection		N/A
	<p>Electrically protective screening interposed between hazardous live parts of a PECS, shall consist of a conductive screen connected to the protective equipotential bonding of the PECS whereby the screen is separated from live parts by at least simple separation.</p> <p>The protective screen and the connection to the protective equipotential bonding system of the PECS and that interconnection shall comply with the requirements of 4.4.4.2/RD.</p>		N/A
4.4.5/RD	Enhanced protection		P
4.4.5.1/RD	General		P
	<p>Enhanced protection shall provide both basic and fault protection and can be achieved by means of:</p> <ul style="list-style-type: none"> • Reinforced insulation in 4.4.5.2/RD; • Protective separation between circuits in 4.4.5.3/RD; • Protection by means of in 4.4.5.4/RD. 		P
4.4.5.2/RD	Reinforced insulation		P

IEC 62040-1			
Clause	Requirement + Test	Result - Remark	Verdict
	Reinforced insulation shall be so designed as to be able to withstand electric, thermal, mechanical and environmental stresses with the same reliability of protection as provided by double insulation. (basic insulation and supplementary insulation, see 4.4.3.2/RD and 4.4.4.5/RD)		P
4.4.5.3/RD	Protective separation between circuits		P
	Protective separation between a circuit and other circuits shall be achieved by one of the following means: <ul style="list-style-type: none"> • double insulation (basic insulation and supplementary insulation in 4.4.3.2/RD and 4.4.4.5/RD); • reinforced insulation in 4.4.5.2/RD; • electrically protective screening in 4.4.4.7/RD; • a combination of these provisions. 		P
	If conductors of the separated circuit are contained together with conductors of other circuits in a multi-conductor cable or in another grouping of conductors, they shall be insulated, individually or collectively, for the highest voltage present, so that double insulation is achieved. If any component is connected between the separated circuits, that component shall comply with the requirements for protective impedance devices (see 4.4.5.4/RD)		P
4.4.5.4/RD	Protection by means of protective impedance		N/A
	Protective impedance shall be arranged so that under both normal and single fault conditions the current and discharge energy available shall be limited according to 4.4.3.4/RD.		N/A
	The protective impedances shall be designed and tested to withstand the impulse voltages and temporary overvoltages for the circuits to which they are connected. See 5.2.3.2/RD and 5.2.3.4/RD for tests.		N/A
	Compliance with the requirement for the limitation of touch current is checked by test of 5.2.3.6/RD.		N/A
	Compliance with the requirement for the discharge energy shall be checked by performing calculations and/or measurements to determine the voltage and capacitance. NOTE A protective impedance designed according to this subclause is not considered to be a galvanic connection.		N/A
4.4.6/RD	Protective measures		P

IEC 62040-1			
Clause	Requirement + Test	Result - Remark	Verdict
4.4.6.1/RD	General		P
4.4.6.2/RD	Protective measures for protective class I equipment		P
	Protective class I equipment shall meet the requirements for: <ul style="list-style-type: none"> • basic protection in 4.4.3/RD; and • fault protection in 4.4.4.2/RD and 4.4.4.3/RD with respect to equipotential bonding and PE conductor. 		P
4.4.6.3/RD	Protective measures for protective class II equipment		N/A
	<p>Protective class II equipment shall meet the requirements for enhanced protection according to 4.4.5/RD and the enclosure shall meet the requirement for basic protection in 4.4.3/RD with respect to accessibility to hazardous live parts. Protective class II equipment shall not have means of connection for the PE conductor. This does not apply if a PE conductor is passed through the equipment to equipment series-connected beyond it.</p> <p>In the latter case the PE conductor and its means for connection shall be separated from:</p> <ul style="list-style-type: none"> · accessible surface of the equipment; and · circuits which employ protective separation with at least simple separation according to the requirement in 4.4.4.6/RD. <p>The simple separation shall be designed according to the rated voltage of the series-connected equipment.</p> <p>Equipment of protective class II may have provision for the connection of an earthing conductor for functional reasons or for the damping of overvoltages. In this case, the functional earthing conductor shall be separated from:</p> <ul style="list-style-type: none"> · accessible surface of the equipment; and · circuits which employ protective separation according to 4.4.5.3/RD <p>with at least protective separation according to the requirement in 4.4.5.3/RD.</p> <p>Equipment of protective class II shall be marked according to 6.3.7.3.3/RD.</p> <p>Compliance is checked by inspection.</p>		N/A
4.4.6.4/RD	Protective measures for protective class III equipment or circuits	<i>Communication circuits</i>	P
4.4.6.4.1/RD	General		P

IEC 62040-1			
Clause	Requirement + Test	Result - Remark	Verdict
	<p>Protective measures shall be achieved by protective separation by one of the following means:</p> <ul style="list-style-type: none">• basic insulation and supplementary insulation (double insulation) according to 4.4.3.2/RD and 4.4.4.5/RD;• reinforced insulation according to 4.4.5.2/RD;• electrically protective screening and simple separation according to 4.4.4.7/RD; or• a combination of these provisions; <p>used in combination with one of the following means:</p> <ul style="list-style-type: none">• protective impedance according to 4.4.5.4/RD comprising limitation of discharge energy and of current; or• limitation of voltage according to 4.4.3.5/RD.		P
	<p>The protective separation shall be fully and effectively maintained under all conditions of intended use of the PECS.</p>		P
4.4.6.4.2 /RD	<p>Connection to PELV and SELV circuits</p>		N/A

IEC 62040-1			
Clause	Requirement + Test	Result - Remark	Verdict
	<p>If a port is intended for connection of an external PELV or SELV circuit with a higher voltage than DVC As:</p> <ul style="list-style-type: none"> • measures to limit the voltage to that of DVC As shall be taken (see Annex A); or • basic protection shall be provided. <p>For connectors containing pins with very small contact area (< 1 mm²), the next higher voltage level for DVC As, of Table 5, is permitted. Example: if DVC A1 is DVC As, then DVC A2 is permitted at pins of signal connectors.</p> <p>The connection of external PELV or SELV circuits to an internal circuit is permitted with the following consideration:</p> <ul style="list-style-type: none"> • without measures: only if the DVC of the PELV and SELV voltage are lower than or equal to the DVC selected from Table 5 for the internal circuit under consideration; and • with measures: if the DVC of the PELV and SELV voltage are higher than the DVC selected from Table 5 for the internal circuit under consideration. <p>The possibility of an addition of the voltages of the circuits under consideration to a higher level under fault conditions shall be considered.</p> <p>For marking, see 6.3.7.1/RD.</p> <p>Consideration needs to be given to factors such as whether the circuits involved are earthed or not, what the voltages involved are, whether or not direct contact with live parts is possible, single faults in either equipment or the interconnections, etc.</p>		N/A
4.4.7/RD	Insulation		P
4.4.7.1/RD	General		P
4.4.7.1.1 4.4.7.1.1 /RD	Influencing factors		P
	This subclause gives minimum requirements for insulation, based on the principles of IEC 60664.		P
	<p>Insulation shall be selected after consideration of the following influences:</p> <ul style="list-style-type: none"> - pollution degree; - overvoltage category; - supply system earthing; - impulse withstand voltage, temporary overvoltage and working voltage; - location of insulation; - type of insulation. 		P

IEC 62040-1			
Clause	Requirement + Test	Result - Remark	Verdict
	Verification of insulation shall be made according to 5.2.2.1/RD, 5.2.3.2/RD, 5.2.3.4/RD and 5.2.3.5/RD. The working voltage can also be measured in accordance with Annex A.		P
4.4.7.1.2 4.4.7.1.2 /RD	Pollution degree		P
	Insulation, especially when provided by clearances and creepage distances, is affected by pollution which occurs during the expected lifetime of the PECS. The micro-environmental conditions for insulation shall be applied according to Table 8.		P
	The pollution degree shall be determined according to the environmental condition for which the product is specified. See Table 18 for selection of pollution degree according to environmental classification of the installation.		P
	The insulation may be determined according to pollution degree 2 if one of the following applies: a) instructions are provided with the PECS indicating that it shall be installed in a pollution degree 2 environment; or b) the specific installation application of the PECS is known to be a pollution degree 2 environment; or c) the PECS enclosure or coatings applied within the PECS according to 4.4.7.8.4.2/RD or 4.4.7.8.6/RD provide adequate protection against what is expected in pollution degree 3 and 4 (conductive pollution and condensation).	<i>Pollution degree 2</i>	P
	The PECS manufacturer shall state in the documentation the pollution degree for which the PECS has been designed.		P
	If operation in a pollution degree 4 environment is required, protection against conductive pollution shall be provided by means of a suitable enclosure.		N/A
	Unless otherwise specified by the UPS manufacturer, the UPS shall be suitable for installation in environments in which the pollution degree is 2 (PD2), see IEC 62477-1: 2012, Table 8.		P
4.4.7.1.3 4.4.7.1.3 /RD	Overvoltage category (OVC)		P

IEC 62040-1			
Clause	Requirement + Test	Result - Remark	Verdict
	<p>Four categories are considered.</p> <ul style="list-style-type: none"> • Equipment of overvoltage category IV (OVC IV) is for use at the origin of the installation. • Equipment of overvoltage category III (OVC III) is equipment in fixed installations and for cases where the reliability and the availability of the equipment are subject to special requirements. • Equipment of overvoltage category II (OVC II) is energy-consuming equipment to be supplied from the fixed installation. • Equipment of overvoltage category I (OVC I) is equipment for connection to circuits in which measures are taken to limit transient overvoltages to an appropriately low level. 		P
	<p>The measures for reduction of the impulse voltage shall ensure that the temporary overvoltages that could occur are sufficiently limited so that their peak value does not exceed the relevant rated impulse voltage of Table 9 and shall meet the requirement of 4.4.7.2.2/RD, 4.4.7.2.3/RD and 4.4.7.3/RD as applicable.</p>		P
	<p>As a minimum, the UPS shall be suitable for installation in environments presenting overvoltage categories listed in Table 102.</p> <p>For UPS units designed to be part of a parallel configuration, the current to be considered in Table 102 is that provided by the parallel configuration.</p>		P
	<p>If measures are provided to reduce impulses of overvoltage category III to values of category II, or values of category II to values of category I, appropriate insulation may be designed to the reduced values, provided that following a single failure, e.g. of the reduction measure, at least the basic insulation requirements for the original overvoltage category shall be fulfilled.</p>		P
4.4.7.1.4 /RD	Supply system earthing		P

IEC 62040-1			
Clause	Requirement + Test	Result - Remark	Verdict
	<p>The following three basic types of system earthing are described in IEC 60364-1.</p> <ul style="list-style-type: none"> • TN system: has one point directly earthed, the accessible conductive parts of the installation being connected to that point by protective conductors. Three types of TN system, TN-C, TN-S and TN-C-S, are defined according to the arrangement of the neutral and protective conductors. • TT system: has one point directly earthed, the accessible conductive parts of the installation being connected to earth electrodes electrically independent of the earth electrodes of the power system. • IT system: has all live parts isolated from earth or one point connected to earth through an impedance, the accessible conductive parts of the installation being earthed independently or collectively to the system earthing. 		P
4.4.7.1.5 /RD	Determination of impulse withstand voltage and temporary overvoltage		P
	<p>Table 9 uses the system voltage (see 4.4.7.1.6/RD) and overvoltage category of the circuit under consideration to determine the impulse withstand voltage. The system voltage is also used to determine the temporary overvoltage.</p> <p>A PECS having more than one input or output shall be evaluated according to the input or output which gives the most severe requirements.</p>		P
4.4.7.1.6 /RD	Determination of the system voltage		P
4.4.7.1.6.1 /RD	For mains supply		P
4.4.7.1.6.2 /RD	For non-mains supply		N/A
	For PSCS supplied by non-mains a.c. or d.c., the system voltage is the r.m.s. value of the supply voltage between phases.		N/A
4.4.7.1.7 /RD	Components bridging insulation		P
	Components bridging insulation shall comply with the requirements of the level of insulation (e.g. basic, reinforced, double) they are bridging.		P

IEC 62040-1			
Clause	Requirement + Test	Result - Remark	Verdict
	A capacitor connected between two line conductors in a primary circuit, or between one line conductor and the neutral conductor or between the primary circuit and protective earth shall comply with one of the subclasses of IEC 60384-14 or with the requirement of 4.4.7.1.7 of IEC 62477-1: 2012 and shall be used in accordance with its rating for voltage and current		P
	For equipment to be connected to IT power distribution systems components connected between line and earth shall be rated for the line-to-line voltage. However, capacitors rated for the applicable line-to-neutral voltage are permitted in such applications if they comply with subclass Y1, Y2 or Y4 of IEC 60384-14		P
4.4.7.2/RD	Insulation to the surroundings		P
4.4.7.2.1 /RD	General		P
4.4.7.2.2 4.4.7.2.2 /RD	Circuits connected to mains supply		P
	Insulation between the surroundings and circuits which are connected directly to the mains supply shall be designed according to the impulse withstand voltage, temporary overvoltage, or working voltage, whichever gives the most severe requirement.		P
4.4.7.2.3 /RD	Circuits connected to non-mains supply		N/A
	Insulation between the surroundings and circuits supplied from a non-mains supply shall be designed according to: <ul style="list-style-type: none"> • the impulse withstand voltage determined from Table 9 using the system voltage; • the working voltage; • the temporary overvoltage if known to exist due to the nature of the supply; whichever gives the more severe requirement.		N/A
	Temporary overvoltage on a non-mains supply shall be determined as follows: <ul style="list-style-type: none"> • Without detailed knowledge of the temporary overvoltage, it shall be according to Table 9. • If the temporary overvoltage is known this value shall be used. 		N/A

IEC 62040-1			
Clause	Requirement + Test	Result - Remark	Verdict
	<p>By the determination of temporary overvoltages on non-mains supply, following situations should be considered:</p> <ul style="list-style-type: none"> • loss of the neutral in a non-mains low-voltage system; • accidental earthing of a non-mains low voltage IT system; and • short circuit in the non-mains low voltage installation. 		N/A
4.4.7.2.4 /RD	Insulation between circuits		P
	<p>Insulation between two circuits shall be designed according to the circuit having the more severe requirement.</p> <p>For the design of simple and protective separation between circuits the insulation shall be designed according to:</p> <ul style="list-style-type: none"> • the circuit having the more severe requirement; or • the working voltage between the circuits; <p>whichever gives the most severe requirement.</p>		P
4.4.7.3/RD	Functional insulation		P

IEC 62040-1			
Clause	Requirement + Test	Result - Remark	Verdict
	<p>If the failure of functional insulation does not produce a hazard (electrical, thermal, fire), no specific requirements apply for the dimensioning of functional insulation. In other cases the following requirements apply.</p> <p>Testing is not required, except where the circuit analysis required by 4.2/RD shows that failure of the insulation could result in a hazard.</p> <p>For parts or circuits that are significantly affected by external transients, functional insulation shall be designed according to the impulse withstand voltage of overvoltage category II, except that overvoltage category III shall be used when the PECS is connected at the origin of the installation.</p> <p>Where measures are provided that reduce transient overvoltages within the circuit from category III to values of category II, or values of category II to values of category I, functional insulation may be designed for the reduced values.</p> <p>Where the circuit characteristics can be shown by testing (see 5.2.3.2/RD) to reduce impulse voltages, functional insulation may be designed for the highest impulse voltage occurring in the circuit during the tests.</p> <p>For parts or circuits that are not significantly affected by external transients, functional insulation shall be designed according to the working voltage across the insulation.</p>		P
4.4.7.4/RD	Clearance distance		P
4.4.7.4.1 /RD	Determination	See Table 4.4.7.4/RD	P
	<p>Clearances for functional, basic and supplementary insulation shall be dimensioned according to Table 10 (see Annex D for examples of the evaluation of clearance distances). Interpolation is permitted, when clearance is determined from temporary overvoltage or working voltage.</p> <p>Clearances for reinforced insulation shall be dimensioned to withstand an impulse voltage one step higher than the impulse withstand voltage, or 1,6 times the peak temporary overvoltage or peak working voltage, required for basic insulation.</p> <p>Clearance distances for use in altitudes between 2 000 m and 20 000 m shall be calculated using a correction factor according to Table A.2 of IEC 60664-1:2007, which is reproduced as Table E.1.</p> <p>A correction factor selected from Table F.2 is also used for determination of clearance distances for approximately homogenous fields when frequencies are greater than 30 kHz, as given in Annex F.</p>		P

IEC 62040-1			
Clause	Requirement + Test	Result - Remark	Verdict
	Compliance shall be checked by visual inspection (see 5.2.2.1/RD) or by performing the impulse voltage test of 5.2.3.2/RD and the a.c. or d.c. voltage test of 5.2.3.4/RD.		P
4.4.7.4.2 /RD	Electric field homogeneity		N/A
	<p>The dimensions in Table 10 correspond to the requirements of an inhomogeneous electric field distribution across the clearance, which are the conditions normally experienced in practice. If a homogeneous electric field distribution is known to exist, the clearance distance for basic or supplementary insulation may be reduced to not less than that required by Table F.2 (Case B) of IEC 60664-1:2007. In this case, however, the impulse voltage test of 5.2.3.2/RD shall be performed across the considered clearance.</p> <p>If the withstand against steady state voltages, recurring peak or temporary overvoltages according to Table 10 is decisive for the dimensioning of clearance and if these clearances are smaller than the values of Table 10 then an a.c. or d.c. voltage test according to 5.2.3.4/RD is required. Clearance distances for reinforced insulation shall not be reduced for homogeneous fields.</p>		N/A
4.4.7.4.3 /RD	Clearance to conductive enclosure		P
	The clearance between any non-insulated live part and the walls of a metal enclosure shall be in accordance with 4.4.7.4.1/RD during and following the deflection tests of 5.2.2.4.2/RD.		P
	Compliance is checked by inspection and by test of 5.2.2.4.2/RD.		P
	If the design clearance distance is at least 12,7 mm and the clearance distance required by 4.4.7.4.1/RD does not exceed 8 mm, the deflection tests may be omitted.		N/A
4.4.7.5/RD	Creepage distances		P
4.4.7.5.1 /RD	Insulating material groups		P
	Creepage distance requirements for PWBs exposed to pollution degree 3 environmental conditions shall be determined based on Table 11 pollution degree 3 under "Other insulators".		P
	For inorganic insulating materials, for example glass or ceramic, which do not track, the creepage distance may equal the associated clearance distance, as determined from Table 10.		P

IEC 62040-1			
Clause	Requirement + Test	Result - Remark	Verdict
4.4.7.5.2 /RD	Determination	See Table 4.4.7.5/RD	P
	Creepage distances for functional, basic and supplementary insulation shall be dimensioned according to Table 11. Interpolation is permitted. Creepage distances for reinforced insulation shall be twice the distances required for basic insulation.		P
	When the creepage distance requirement determined from Table 11 is less than the clearance distance required by 4.4.7.4.1/RD or the clearance distance determined by impulse testing (see 5.2.3.2/RD), then the creepage distance shall be increased to the clearance distance.		P
	Compliance of creepage distances shall be checked by measurement or inspection (see 5.2.2.1/RD) (see Annex D for examples of the evaluation of creepage distances).		P
4.4.7.6/RD	Coating		N/A
	A coating may be used to provide insulation, to protect a surface against pollution, and to allow a reduction in creepage and clearance distances (see 4.4.7.8.4.2/RD and 4.4.7.8.6/RD)		N/A
4.4.7.7 4.4.7.7/RD	PWB spacings for functional insulation		P
	Spacings for functional insulation shall comply with the requirement of 4.4.7.4/RD and 4.4.7.5/RD.		P
	Decreased spacing for components mounted on PWB or decreased spacing on PWB are permitted when all the following are satisfied: <ul style="list-style-type: none"> • the PWB has flammability rating of V-0 (see IEC 60695-11-10); • the PWB base material has a minimum CTI of 100; • the equipment complies with the PWB short circuit test (see 5.2.4.7/RD). Decreased spacings for components assembled on PWB are permitted when used in: <ul style="list-style-type: none"> • pollution degree 1 or 2 environment; and • not more than overvoltage category I. In this case the manufacture specification may be used. Compliance is checked by inspection and by test of 5.2.4.7/RD if applicable.		N/A
4.4.7.8/RD	Solid insulation		P
4.4.7.8.1 /RD	General		P

IEC 62040-1			
Clause	Requirement + Test	Result - Remark	Verdict
	<p>Materials selected for solid insulation shall be able to withstand the stresses occurring. These include mechanical, electrical, thermal, climatic and chemical stresses which are to be expected in normal use. Insulation materials shall also be resistant to ageing during the expected lifetime of the PECS.</p> <p>Tests shall be performed on components and sub-assemblies using solid insulation, in order to ensure that the insulation performance has not been compromised by the design or manufacturing process.</p>		P
4.4.7.8.2 /RD	Material requirements		P
	<p>The insulating material shall have a CTI of 100 or greater.</p> <p>The insulating material shall be suitable for the maximum temperature it attains as determined by the temperature rise test of 5.2.3.10/RD.</p> <p>Consideration shall be given as to whether or not the insulating material additionally provides mechanical strength and whether or not the part can be subject to impact during use.</p>		P
	<p>The insulating material in contact with live parts higher than DVC As shall comply with:</p> <ul style="list-style-type: none"> • the glow-wire test described in 5.2.5.3/RD at a test temperature of 850 °C; or • the glow-wire test described in 5.2.5.3/RD, at a lower test temperature, but not less than 550 °C, depending on the classification of the use of the PECS, according to Table A.1 of IEC 60695-2-11:2011; or • the alternative hot wire ignition test of 5.2.5.4/RD 		N/A
	Thermoplastic insulating materials used in contact with live parts higher than DVC As or used as part of the enclosure shall comply with the ball pressure test as abnormal heat test according to IEC 60695-10-2.		N/A
	Where an insulating material is used in a PECS that incorporates switching contacts, and is within 12,7 mm of the contacts, it shall comply with the high current arcing ignition test of 5.2.5.2/RD.		N/A
	<p>In case the manufacturer of the insulating material provides data to demonstrate compliance with the above requirements no further testing is required.</p> <p>No further evaluation is required when generic materials are used according to Table 12.</p>		P

IEC 62040-1			
Clause	Requirement + Test	Result - Remark	Verdict
	Compliance is checked by inspection and by test of 5.2.3.10/RD and 5.2.5.3/RD or 5.2.5.2/RD.		P
4.4.7.8.3 /RD	Thin sheet or tape material		P
4.4.7.8.3.1 /RD	General	See Table 4.4.7. /RD	P
	<p>4.4.7.8.3/RD applies to the use of thin sheet or tape materials in assemblies such as wound components and bus-bars.</p> <p>Insulation consisting of thin (less than 0,75 mm) sheet or tape materials is permitted, provided that it is protected from damage and is not subject to mechanical stress under normal use.</p> <p>Where more than one layer of insulation is used, there is no requirement for all layers to be of the same material.</p> <p>NOTE 1 One layer of insulation tape wound with more than 50 % overlap is considered to constitute two layers.</p> <p>NOTE 2 Basic, supplementary and double insulation can be applied as a pre-assembled system of thin materials.</p>		P
4.4.7.8.3.2 /RD	Material thickness equal to or more than 0,2 mm		P
	Basic or supplementary insulation shall consist of at least one layer of material, which will meet the requirements of 4.4.7.8.1/RD and 4.4.7.10.1/RD.		P
	Double insulation shall consist of at least two layers of material, each of which will meet the requirements of 4.4.7.8.1/RD, 4.4.7.10.1/RD, and the partial discharge requirements of 4.4.7.10.2/RD, and both layers together will meet the impulse and a.c. or d.c. voltage requirements of 4.4.7.10.2/RD.		P
	Reinforced insulation shall consist of a single layer of material, which will meet the requirements of 4.4.7.8.1/RD and 4.4.7.10.2/RD.		N/A
	NOTE The requirements of this subclause indicate that double insulation can be at least 0,4 mm thick, while reinforced insulation is permitted to be 0,2 mm thick.		P
4.4.7.8.3.3 /RD	Material thickness less than 0,2 mm		N/A
	Basic or supplementary insulation shall consist of at least two layers of material, which will meet the requirements of 4.4.7.8.1/RD and 4.4.7.10.1/RD.		N/A

IEC 62040-1			
Clause	Requirement + Test	Result - Remark	Verdict
	Double insulation shall consist of at least three layers of material. Each layer shall meet the requirements of 4.4.7.8.1/RD and 4.4.7.10.1/RD, and any two layers together shall meet the requirements of 4.4.7.10.2/RD.		N/A
	Reinforced insulation consisting of a single layer of material is not permitted.		N/A
4.4.7.8.3.4 /RD	Compliance		P
	Compliance shall be checked by the tests described in 5.2.3.1/RD to 5.2.3.5/RD. When a component or sub-assembly makes use of thin sheet insulating materials, it is permitted to perform the tests on the component rather than on the material.		P
4.4.7.8.4 /RD	Printed wiring boards (PWBs)		P
4.4.7.8.4.1 /RD	General		P
	Insulation between conductor layers in double-sided single-layer PWBs, multi-layer PWBs and metal core PWBs, shall meet the requirements of 4.4.7.8.1/RD. Basic, supplementary, double and reinforced insulation shall meet the appropriate requirements of 4.4.7.10.1/RD or 4.4.7.10.2/RD. Functional insulation in PWBs shall meet the requirements of 4.4.7.7/RD. For the inner layers of multi-layer PWBs, the insulation between adjacent tracks on the same layer shall be treated as either: <ul style="list-style-type: none"> • a creepage distance for pollution degree 1 and a clearance as in air (see Example D.14); or • solid insulation, in which case it shall meet the requirements of 4.4.7.8.1/RD and 4.4.7.10/RD. 		P
4.4.7.8.4.2 /RD	Use of coating materials		N/A
	A coating material used to provide functional, basic, supplementary and reinforced insulation shall meet the requirement as specified below.		N/A
	Type 1 protection (as defined in IEC 60664-3) improves the microenvironment of the parts under protection. The clearance and creepage distance of Table 10 and Table 11 for pollution degree 1 apply under the protection. Between two conductive parts, it is a requirement that one or both conductive parts, together with all the spacing between them, are covered by the protection.		N/A

IEC 62040-1			
Clause	Requirement + Test	Result - Remark	Verdict
	Type 2 protection is considered to be similar to solid insulation. Under the protection, the requirements for solid insulation specified in 4.4.7.8/RD are applicable, including the coating material itself, and spacings shall not be less than those specified in Table 1 of IEC 60664-3:2003. The requirements for clearance and creepage in Table 10 and Table 11 do not apply. Between two conductive parts, it is a requirement that both conductive parts, together with the spacing between them, are covered by the protection so that no air gap exists between the protective material, the conductive parts and the printed boards.		N/A
	The coating material used to provide Type 1 and Type 2 protection shall be designed to withstand the stresses anticipated to occur during the expected lifetime of the PECS. A type test on representative PWBs shall be conducted according to Clause 5 of IEC 60664-3:2003. For the cold test (5.7.1 of IEC 60664-3:2003), a temperature of -25 °C shall be used, and for the rapid change of temperature test (5.7.3 of IEC 60664-3:2003): -25 °C to +125 °C. No routine test is required.		N/A
4.4.7.8.5 /RD	Wound components		P
	Varnish or enamel insulation of wires shall not be used for basic, supplementary, double or reinforced insulation. Wound components shall meet the requirements of 4.4.7.8.1/RD and 4.4.7.10/RD. The component itself shall pass the requirements given in 4.4.7.8.1/RD and 4.4.7.10.2/RD. If the component has reinforced or double insulation, the a.c. or d.c. voltage test of 5.2.3.4/RD shall be performed as a routine test.		P
4.4.7.8.6 /RD	Potting materials		N/A
	A potting material may be used to provide solid insulation or to act as a coating to protect against pollution.		N/A
	If used as solid insulation, it shall comply with the requirements of 4.4.7.8.1/RD and 4.4.7.10/RD.		N/A
	If used to protect against pollution, the requirements for Type 1 protection in 4.4.7.8.4.2/RD apply.		N/A
4.4.7.9/RD	Connection of parts of solid insulation (cemented joints)		N/A

IEC 62040-1			
Clause	Requirement + Test	Result - Remark	Verdict
	<p>The creepage and clearance path in the presence of a cemented joint between two insulating parts, are determined as follows.</p> <ul style="list-style-type: none"> • Type 1 or type 2 protection as described in 4.4.7.8.4.2/RD apply. • A cemented joint that is not evaluated as providing protection of type 1 or type 2, is neither considered solid insulation nor to reduce pollution degree. The clearance and creepage distances of Table 10 and Table 11 apply for the pollution degree of the environment around the joint. See 5.2.5.7/RD for test. 		N/A
4.4.7.10 /RD	Requirements for electrical withstand capability		P
4.4.7.10.1 /RD	Basic or supplementary insulation	See Table 4.4.7.10/RD	P
	Test with impulse withstand voltage according to 5.2.3.1/RD		P
	Test with a.c. or d.c. voltage according to 5.2.3.4/RD		P
4.4.7.10.2 /RD	Double or reinforced insulation	See Table 4.4.7.10	P
	<p>Double or reinforced insulation shall be tested as follows:</p> <ul style="list-style-type: none"> • Test with impulse withstand voltage according to 5.2.3.2/RD; and • Test with a.c. or d.c. voltage according to 5.2.3.4/RD. 		P
	<p>For solid insulation, the partial discharge test according to 5.2.3.5/RD shall be performed in addition to the above tests, if the recurring peak working voltage across the insulation is greater than 750 V and the voltage stress on the insulation is greater than 1 kV/mm.</p> <p>The partial discharge test shall be performed as a type test on all components, sub-assemblies and PWB. In addition, a sample test shall be performed if the insulation consists of a single layer of material.</p>		N/A
	Double insulation shall be designed so that failure of the basic insulation or of the supplementary insulation will not result in reduction of the insulation capability of the remaining part of the insulation.		P
4.4.7.11 /RD	Insulation requirements above 30kHz		P
4.4.8/RD	Compatibility with residual current-operated protective devices (RCD)		N/A

IEC 62040-1			
Clause	Requirement + Test	Result - Remark	Verdict
	<p>To ensure the intended work of an RCD provided by the installation PECS shall satisfy one of the following conditions.</p> <p>a) A Pluggable Type A single-phase PECS, shall be designed so that, under normal and fault conditions any resulting d.c. component of the current in the PE conductor does not exceed the d.c. current withstand requirements in IEC 60755 for RCD of type A.</p> <p>b) For PECS that are Pluggable Type B or intended for permanent connection, d.c. current in the PE conductor is not limited if the information and marking requirements of 6.3.7.4/RD are complied with.</p>		N/A
	<p>Compliance with RCD provided by the installation shall be checked by simulation or calculation of current in the PE conductor under normal and single fault conditions according to the guideline provided in Annex H/RD.</p>		N/A
4.4.9 4.4.9/RD	Capacitor discharge		P
	<p>For protection against shock hazard, capacitors within a PECS shall be discharged to a voltage less than DVC As, or to a residual charge less than 50 μC, after the removal of power from the PECS:</p> <ul style="list-style-type: none"> • for pluggable UPS type A, the discharge time shall not exceed 1 s or the hazardous live parts shall be protected against direct contact by at least IPXXB (see 4.4.3.3); • for pluggable UPS type B, the discharge time shall not exceed 5 s or the hazardous live parts shall be protected against direct contact by at least IPXXB (see 4.4.3.3); • for permanently connected UPS, the discharge time shall not exceed 15 s. <p>For pluggable PECS type A and B and permanently connected PECS, which do not meet the above requirements, access shall only be possible by means of a tool or key and the information and marking requirements of 6.5.2/RD apply.</p> <p>Compliance is checked by test of 5.2.3.8/RD.</p>	<p><i>Equipment marked with symbol ISO 7010-W012 and text "Discharge time 5 minutes"</i></p>	P
4.5	Protection against electrical energy hazards		P
4.5.1/RD	Operator access areas		P
4.5.1.1/RD	General		P

IEC 62040-1			
Clause	Requirement + Test	Result - Remark	Verdict
	<p>Equipment shall be so designed that there is no risk of electrical energy hazard in operator access areas from accessible circuits by fulfilling requirement of 4.2/RD.</p> <p>A risk of injury due to an electrical energy hazard exists if it is likely that two or more bare parts (one of which may be earthed) between which a hazardous energy level exists, will be bridged by a metallic object.</p> <p>The likelihood of bridging the parts under consideration is determined by means of the test finger of Figure 1 of IEC 60529:1989, in a straight position. If it is possible to bridge the parts with this test finger, a hazardous energy level shall not exist.</p> <p>Barriers, guards, and similar means preventing unintentional contact may be provided as an alternative to limiting the energy.</p>		P
	Compliance is checked by inspection or test of 5.2.2.2/RD.		P
4.5.1.2/RD	Determination of hazardous electrical energy level		P
	<p>A hazardous electrical energy level is considered to exist if:</p> <ul style="list-style-type: none"> • the voltage is 2 V or more; <p>and</p> <ul style="list-style-type: none"> • power available exceeds 240 VA after 60 s; or • the energy exceeds 20 J. <p>Compliance shall be checked with the test in 5.2.3.9/RD or by calculation.</p>		P
4.5.2 4.5.2/RD	Service access areas		P
	Capacitors within a PECS shall be discharged to an energy level less than 20 J, as in 4.5.1.2, within 5 s after the removal of power from the PECS. If this requirement is not achievable for functional or other reasons, the information and marking requirements of 6.5.2/RD apply.	<i>the information and marking requirements of 6.5.2 provided</i>	P

IEC 62040-1			
Clause	Requirement + Test	Result - Remark	Verdict
	<p>This requirement does not apply to terminals covered by 4.4.9.</p> <p>In a service access area, the following requirements apply.</p> <p>Bare parts at hazardous voltage shall be located or guarded so that unintentional contact with such parts is unlikely during service operations involving other parts of the equipment. Bare parts at hazardous voltage shall be located or guarded so that accidental shorting to parts at non-hazardous potentials (for example, by tools or test probes used by a service person) is unlikely.</p>		N/A
	If the capacitor discharge time cannot be accurately calculated, the discharge time shall be measured.		P
4.6	Protection against fire and thermal hazards		P
4.6.1/RD	Circuits representing a fire hazard		P
	<p>The following types of circuits are considered a fire hazard:</p> <ul style="list-style-type: none"> - circuits directly connected to the mains - circuits that are not directly connected to the mains but exceed the limits for limited power sources in 4.6.5/RD - components having unenclosed arcing parts 		P
4.6.2/RD	Components representing a fire hazard		P
4.6.2.1/RD	General		P
	Compliance with 4.6.2/RD and 4.6.3/RD shall be confirmed by inspection of component and material data sheets and, where necessary, by test.		P
4.6.2.2 4.6.2.2/RD	Components within a circuit representing a fire hazard		P
	Inside fire enclosures, materials for components and other parts and all materials in contact with such parts shall comply with flammability class V-2 as classified in IEC 60695-11-10 or flammability class HF-2 as classified in ISO 9772 or better.		P

IEC 62040-1			
Clause	Requirement + Test	Result - Remark	Verdict
	<p>The above requirement does not apply to any of the following:</p> <ul style="list-style-type: none"> • electrical components which do not present a fire hazard under abnormal operating conditions when tested according to 5.2.4.6/RD; • materials and components within an enclosure of 0,06 m³ or less, consisting totally of metal and having no ventilation openings, or within a sealed unit containing an inert gas; • electronic components, such as integrated circuit packages, opto-coupler packages, capacitors and other small parts that are mounted on material of flammability class V-1 or better; • wiring, cables and connectors insulated with PVC, TFE, PTFE, FEP, neoprene or polyimide; • the following parts, provided that they are separated from electrical parts (other than insulated wires and cables) which under fault conditions are likely to produce a temperature that could cause ignition, by at least 13 mm of air or by a solid barrier of material of flammability class V-1 or better: <ul style="list-style-type: none"> – other small parts which would contribute negligible fuel to a fire, including, labels, mounting feet, key caps, knobs and the like; – tubing for air or any fluid systems, containers for powders or liquids and foamed plastic parts, provided that they are of flammability class HB. 		P
	Batteries shall have a flammability class HB or better.		P
4.6.2.3/RD	Components within a circuit not representing a fire hazard		P
	For components within a circuit not representing a fire hazard 4.6.2/RD does not apply.		P
4.6.3/RD	Fire enclosure		P
4.6.3.1 4.6.3.1/RD	General		P

IEC 62040-1			
Clause	Requirement + Test	Result - Remark	Verdict
	<p>Fire enclosures are used to reduce the risk of fire to the environment, independent of the location where they are installed.</p> <p>A fire enclosure shall be provided for all UPS unless:</p> <ul style="list-style-type: none"> • circuits inside of an enclosure are within the limits of limited power sources in 4.6.5 of this document; or • there is an agreement between the user and the manufacturer; or • the UPS is intended to be used only in areas without combustible materials and is marked according to 6.3.5/RD. 		P
4.6.3.2/RD	Flammability of enclosure materials		P
	Materials used for fire enclosures of PECS shall meet the flammability test requirements of 5.2.5.5/RD, except for those portions of the enclosure that enclose only circuits not representing a fire hazard.	<i>Metal enclosure</i>	P
	Materials are considered to comply without test if, in the minimum thickness used, the material is of flammability class 5VA or better, according to IEC 60695-11-20.		P
	For movable UPS having a total mass not exceeding 18 kg, materials are considered to comply without test if, in the minimum thickness used, the materials are of flammability class of V-1 or better, according to IEC 60695-11-10.		N/A
	Metals, ceramic materials, and glass which is heat-resistant tempered, wired or laminated, are considered to comply without test.		P
	<p>Materials for components that fill an opening in a fire enclosure shall:</p> <ul style="list-style-type: none"> • be of at least V-1 class material and no larger than 100 mm in any dimension; or • be of at least V-2 class material and either <ul style="list-style-type: none"> – not larger than 25 mm in any dimension; or – not larger than 100 mm in any dimension and located at least 100mm from any part that is a source of fire hazard; or • be of at least V-2 class material and there is a barrier or device(s) that forms a barrier made of a V-0 class material between the part and a source of fire hazard; or • comply with a relevant IEC component standard that includes flammability requirements for components that are intended to form part of, or fill openings in, a fire enclosure. 		N/A

IEC 62040-1			
Clause	Requirement + Test	Result - Remark	Verdict
	Polymeric materials that serve as the outer enclosure and have surface area greater than 1 m ² or a single dimension larger than 2 m, shall have a maximum flame spread index of 100 as determined by ASTM E162 or ANSI/ASTM E84.		N/A
	The manufacturer may provide data from the fire enclosure material supplier to demonstrate compliance with the above requirements. In this case, no further testing is required.		P
	Compliance shall be checked by visual inspection and, where necessary, by test.	<i>Compliance checked by visual inspection</i>	P
4.6.3.3/RD	Openings in fire enclosure		P
4.6.3.3.1 /RD	General		P
4.6.3.3.2 /RD	Openings in the top and side of fire enclosures		P
	<p>Openings in the top surfaces of fire enclosures shall be designed to prevent an external object falling vertically or at up to 5° from vertically from entering the enclosure in an area that could lead to a fire hazard.</p> <p>This requirement applies to all sides of moveable equipment with no defined top and bottom, unless top and bottom surfaces can be suitably demonstrated in the installation instructions.</p> <p>The test requirements are found in 5.2.2.2 of this document.</p>		P
	<p>Openings in the top surfaces of fire enclosures not located vertically above or within 5° from vertical of a circuit representing a fire hazard as defined in 4.6.1/RD are not subject to the test of 5.2.2.2/RD and can be of any construction if the construction prevents access to parts greater than DVC As with the IP2X probe as detailed in 4.4.3.3/RD.</p> <p>Where a portion of the side of a fire enclosure falls within the area traced out by the 5° angle in Figure 6, the limitations in 4.6.3.3.3/RD regarding openings in bottoms of fire enclosures also apply to this portion of the side.</p> <p>Compliance shall be checked by visual inspection.</p>	No opening in the top surface	P
4.6.3.3.3 /RD	Openings in the bottom of a fire enclosure		N/A
	Compliance is checked by inspection or with the hot flaming oil test in 5.2.5.6/RD, in case the fire enclosure is designed differently than as described in this subclause.	<i>No opening in the bottom of enclosure</i>	N/A

IEC 62040-1			
Clause	Requirement + Test	Result - Remark	Verdict
4.6.3.3.4 /RD	Doors or covers in fire enclosures		P
	<p>If part of a fire enclosure consists of a door or a cover leading to an operator access area, it shall comply with one of the following requirements:</p> <ul style="list-style-type: none"> • the door or cover shall be provided with a safety interlock; or • a door or cover, intended to be routinely opened by the user, shall comply with both of the following conditions: <ul style="list-style-type: none"> – it shall not be removable from other parts of the fire enclosure by the user; and – it shall be provided with a means to keep it closed during normal operation. <p>A door or cover intended only for occasional use by an installer, such as for the installation of accessories, is permitted to be removable provided that the equipment instructions include directions for correct removal and reinstallation of the door or cover.</p> <p>Compliance is checked by inspection.</p>		P
4.6.4/RD	Temperature		P
4.6.4.1 4.6.4.1/RD	Internal parts	See table 4.6.4/RD	P
	<p>Equipment and its component parts shall not attain temperatures in excess of those in Table 14 when tested in normal mode in accordance with the ratings of the equipment.</p> <p>Magnetic components shall not attain temperatures in excess of those in Table 103 when tested in stored energy mode in accordance with the ratings of the equipment.</p> <p>Compliance is checked by test of 5.2.3.10/RD.</p>		P
4.6.4.2/RD	Accessible parts		N/A
	When surface temperatures of the PECS, close to mounting surfaces, exceed the limit of Table 15, a warning according to 6.3.5/RD shall be provided.		N/A
4.6.5 4.6.5/RD	Limited power sources		N/A
	<p>Where a limited power source is required, the source shall comply with Table 16 or Table 17 as applicable.</p> <p>Compliance to both the maximum allowed current and maximum apparent power available from the power source is required.</p>		N/A

IEC 62040-1			
Clause	Requirement + Test	Result - Remark	Verdict
	A limited power source shall comply with one of the following requirements: a) the output is inherently limited in compliance with Table 16; or b) a linear or non-linear impedance limits the output in compliance with Table 16. If a positive temperature coefficient device (PTC) is used, it shall pass the tests specified in IEC 60730-1, Clauses 15, 17, J.15 and J.17; or c) a regulating network limits the output in compliance with Table 16, both with and without a single fault in the regulating network; or d) an overcurrent protective device is used and the output is limited in compliance with Table 17.		N/A
	Compliance to determine the maximum available power is checked by test of 5.2.3.9/RD.		N/A
4.7	Protection against mechanical hazards		P
4.7.1/RD	General		P
	Failure of any component within the PECS shall not release sufficient energy to lead to a hazard, for example, expulsion of material into an area occupied by personnel.		P
4.7.2/RD	Specific requirements for liquid cooled PECS	<i>No liquid cooled</i>	N/A
4.7.2.1/RD	General		N/A
4.7.2.2/RD	Coolant		N/A
	Coolant temperature in operation shall not exceed the limit specified in Table 14.		N/A
	Compliance is checked by inspection and test of 5.2.3.10/RD.		N/A
4.7.2.3/RD	Design requirements		N/A
4.7.2.3.1 /RD	General		N/A
	The liquid containment system components shall be compatible with the liquid to be used. Equipment using liquids shall be so constructed that it is unlikely that either a dangerous concentration of these materials or a hazard in the meaning of this standard will be created by condensation, vaporization, leakage, spillage or corrosion during normal operation, storage, filling or emptying. Compliance is checked by inspection. The flexible hoses should be made of material free of conductive contaminants such as carbon.		N/A

IEC 62040-1			
Clause	Requirement + Test	Result - Remark	Verdict
4.7.2.3.2 /RD	Corrosion resistance		N/A
	All cooling system components shall be suitable for use with the specified coolant. They shall be corrosion resistant and shall not corrode as a result of prolonged exposure to the coolant and/or air. Compliance is checked by inspection.		N/A
4.7.2.3.3 /RD	Tubing, joints and seals		N/A
	Cooling system tubing, joints and seals shall be designed to prevent leakage during excursions of pressure over the life of the equipment. The entire cooling system including tubing shall satisfy the requirements of the hydrostatic pressure test of 5.2.7/RD.		N/A
4.7.2.3.4 /RD	Provision for condensation		N/A
	Where internal condensation occurs during normal operation or maintenance, measures shall be taken to prevent degradation of insulation. In those areas where such condensation is expected, clearance and creepage distances of Table 10 and Table 11 shall be evaluated at least for a pollution degree 3 environment (see Table 8), and provision shall be made to prevent accumulation of water (for example by providing a drain). Compliance is checked by inspection.		N/A
4.7.2.3.5 /RD	Leakage of coolant		N/A
	During a leakage measures has to ensure that coolant will not result in wetting of live parts or electrical insulation.		N/A
4.7.2.3.6 /RD	Loss of coolant		N/A
	Loss of coolant form the cooling system shall not result in thermal hazards, explosion, or shock hazard. The requirements of the Loss of coolant test of 5.4.3.9.4/RD shall be satisfied.		N/A
4.7.2.3.7 /RD	Conductivity of coolant		N/A
	When the coolant is intentionally in contact with live parts (for example non-earthed heatsinks), the conductivity of the coolant shall be continuously monitored and controlled, in order to avoid hazardous current flow through the coolant.		N/A

IEC 62040-1			
Clause	Requirement + Test	Result - Remark	Verdict
4.7.2.3.8 /RD	Insulation requirements for coolant hoses		N/A
	When the coolant is intentionally in contact with live parts (for example non-earthed heatsinks), the coolant hoses form a part of the insulation system. Depending on the location of the hoses, the requirements of 4.4.7/RD for functional or simple or protective separation shall be applied where relevant.		N/A
4.7.101	Protection in service access area		P
4.8	Equipment with multiple sources of supply		P
4.8.101	General		P
4.8.102	Backfeed protection		P
4.9 4.9/RD	Protection against environmental stresses		P
	<p>The manufacturer has to specify the following conditions for operation, storage and transportation according to IEC 60721:</p> <ul style="list-style-type: none"> - Coolant temperature (min/max); - Ambient temperature (min/max); - Humidity (min/max) - Pollution degree; - Vibration; - U.V. resistance; - Over voltage category (OVC); - Altitude for thermal consideration, if rated for operation above 1000 m; - Altitude for insulation coordination considerations, if rated for operation above 2000 m. 		P
	<p>The manufacturer shall state the environmental service condition for the PECS according to Table 18.</p> <p>The UPS, as a minimum, shall comply with the following indoor conditions: climatic, pollution degree, and humidity condition of the skin as part of the environmental service condition 3K2 of Table 18 of IEC 62477-1:2012. The manufacturer may elect to comply with environmental service conditions more onerous than 3K2 subject to the UPS being marked accordingly (see 6.2).</p>		P
4.10	Protection against sonic pressure hazards	<i>Equipment does not produce noise at a level which could cause a hazard</i>	N/A
4.11	Wiring and connections		P

IEC 62040-1			
Clause	Requirement + Test	Result - Remark	Verdict
4.11.1/RD	General		P
	<p>The wiring and connections between parts of the equipment and within each part shall be protected from mechanical damage during installation. The insulation, conductors and routing of all wires of the equipment shall be suitable for the electrical, mechanical, thermal and environmental conditions of use. Conductors which are able to contact each other shall be provided with insulation rated for the DVC requirements of the relevant circuits.</p> <p>The compliance with 4.11.2/RD to 4.11.8/RD shall be checked by inspection (see 5.2.1/RD) of the overall construction and datasheets if applicable.</p>		P
4.11.2/RD	Routing		P
	A hole through which insulated wires pass in a sheet metal wall within the enclosure of the equipment shall be provided with a smooth, well-rounded bushing or grommet or shall have smooth, well-rounded surfaces upon which the wires bear to reduce the risk of abrasion of the insulation.		P
	Wires shall be routed away from sharp edges, screw threads, burrs, fins, moving parts, drawers, and similar parts, which abrade the wire insulation. The minimum bend radius specified by the wire manufacturer shall not be violated.		P
	Clamps and guides, either metallic or non-metallic, used for routing stationary internal wiring shall be provided with smooth, well-rounded edges. The clamping action and bearing surface shall be such that abrasion or deformation of the insulation does not occur. If a metal clamp is used for conductors having thermoplastic insulation less than 0,8 mm thick, non-conduction mechanical protection shall be provided.		P
4.11.3/RD	Colour coding		P
	Insulated conductors, other than those which are integral of ribbon cable or multi-cord signal cable, identified by the colour green with or without one or more yellow stripes shall only be used for protective bonding.		P
4.11.4/RD	Splices and connections		P

IEC 62040-1			
Clause	Requirement + Test	Result - Remark	Verdict
	<p>All splices and connections shall be mechanically secured and shall provide electrical continuity.</p> <p>Electrical connections shall be soldered, welded, crimped, or otherwise securely connected. A soldered joint, other than a component on a PWB, shall additionally be mechanically secured.</p> <p>NOTE Stranded wire should not be consolidated with solder where secured in a terminal that relies on pressure for contact or equivalent</p> <p>When stranded internal wiring is connected to a wire-binding screw, the construction shall be such that loose strands of wire do not contact:</p> <ul style="list-style-type: none"> • other uninsulated live parts not always of the same potential as the wire; • de-energized metal parts. <p>When screw terminal connections are used, the resulting connections may require routine maintenance (tightening). Appropriate reference shall be made in the maintenance manual (see 6.5.1/RD).</p>		P
4.11.5/RD	Accessible connections		P
	<p>In addition to measures given in 4.4.6.4/RD it shall be ensured that neither insertion error nor polarity reversal of connectors can lead to a voltage on an accessible connection higher than the maximum of DVC As. This applies for example to plug-in sub-assemblies or other plug-in devices which can be plugged in without the use of a tool or key or which are accessible without the use of a tool or key. This does not apply to equipment intended to be installed in restricted access areas.</p> <p>If relevant, non-interchangeability and protection against polarity reversal of connectors, plugs and socket outlets shall be confirmed by inspection and trial insertion.</p>		P
4.11.6/RD	Interconnection between parts of the PECS		P

IEC 62040-1			
Clause	Requirement + Test	Result - Remark	Verdict
	<p>In addition to complying with the requirements given in 4.11.1/RD to 4.11.5/RD, the means provided for the interconnection between parts of the PECS shall comply with the following requirements or those of 4.11.7/RD.</p> <p>Cable assemblies and flexible cords provided for interconnection between sections of equipment or between units of a system shall be suitable for the service or use involved. Cables shall be protected from physical damage as they leave the enclosure and shall be provided with mechanical strain relief.</p> <p>Misalignment of male and female connectors, insertion of a multipin male connector in a female connector other than the one intended to receive it, and other manipulations of parts which are accessible to the operator shall not result in mechanical damage or a risk of thermal hazards, electric shock, or injury to persons.</p> <p>When external interconnecting cables terminate in a plug which mates with a receptacle on the external surface of an enclosure, no risk of electric shock shall exist at accessible contacts of either the plug or receptacle when disconnected.</p> <p>NOTE An interlock circuit in the cable to de-energize the accessible contacts whenever an end of the cable is disconnected meets the intent of these requirements.</p>		P
4.11.7/RD	Supply connections		P
	The connection points provided shall be of appropriate construction to preclude the possibility of loose strands reducing the spacing between conductors when careful attention is paid to installation.		P
4.11.8/RD	Terminals		P
4.11.8.1/RD	Construction requirements		P

IEC 62040-1			
Clause	Requirement + Test	Result - Remark	Verdict
	<p>All parts of terminals which maintain contact and carry current shall be of metal having adequate mechanical strength.</p> <p>Terminal connections shall be such that the conductors can be connected by means of screws, springs or other equivalent means so as to ensure that the necessary contact pressure is maintained.</p> <p>Terminals shall be so constructed that the conductors can be clamped between suitable surfaces without any significant damage either to conductors or terminals.</p> <p>Terminals shall not allow the conductors to be displaced or be displaced themselves in a manner detrimental to the operation of equipment and the insulation shall not be reduced below the rated values.</p> <p>The requirements of this subclause are met by using terminals complying with IEC 60947-7-1 or IEC 60947-7-2, as appropriate.</p>		P
4.11.8.2 4.11.8.2 /RD	Connecting capacity		P
	Terminals shall be provided which accommodate the conductors specified in the installation and maintenance manuals (see 6.3.6.4/RD) and cables in accordance with the wiring rules applicable at the installation. The terminals shall meet the temperature rise test of 5.2.3.10/RD.		P
	Information regarding the permitted wire sizes shall be given in the installation manual.		P
	The UPS manufacturer shall indicate whether the terminals are suitable for connection of copper or aluminium conductors, or both. The terminals shall be such that the external conductors may be connected by a means (screws, connectors, etc.) which ensures that the necessary contact pressure corresponding to the current rating, the short-circuit strength of the apparatus and the circuit are maintained.		P
	<p>In the absence of a special agreement between the UPS manufacturer and the purchaser, terminals shall be capable of accommodating copper conductors from the smallest to the largest cross-sectional areas corresponding to the appropriate rated current (see Annex AA).</p> <p>Compliance is checked by inspection, by measurement and by fitting at least the smallest and largest cross-sectional areas of the appropriate range in Annex AA.</p>		N/A

IEC 62040-1			
Clause	Requirement + Test	Result - Remark	Verdict
4.11.8.3 /RD	Connection		P
	<p>Terminals for connection to external conductors shall be readily accessible during installation.</p> <p>Sets of terminals for connection to the same input or output shall be grouped together and shall be located in proximity to each other and to the main protective earthing terminal, if any. If the installation instructions provide detail on the proper earthing of the system, the protective earthing terminal need not be placed in proximity to the terminals.</p> <p>Clamping screws and nuts shall not serve to fix any other component although they may hold the terminals in place or prevent them from turning.</p>		P
4.11.8.4 /RD	Wire bending space for wires 10 mm ² and greater		P
	The distance between a terminal for connection to the main supply, or between major parts of the PECS (for example a transformer), and an obstruction toward which the wire is directed upon leaving the terminal shall be at least that specified in Table 19.		P
4.11.101	Non-detachable cords	<i>Stationary equipment with external power connection through terminals. Inlet with smoothly rounded opening.</i>	N/A
4.11.101.1	Cord guard		N/A
4.11.101.2	Cord anchorages and strain relief		N/A
4.12/RD	Enclosures	<i>Test of 5.2.2.4 to 5.2.2.7 performed</i>	N/A
4.12.1/RD	General		N/A
4.12.2/RD	Handle and manual controls		N/A
	Handles, knobs, grips, levers and the like shall be reliably fixed so that they will not work loose in normal use, if this could result in a hazard. Sealing compounds and the like, other than self-hardening resins, shall not be used to prevent loosening. If handles, knobs and the like are used to indicate the position of switches or similar components, it shall not be possible to fix them in a wrong position if this could result in a hazard.		N/A
4.12.3/RD	Cast metal		N/A

IEC 62040-1			
Clause	Requirement + Test	Result - Remark	Verdict
	<p>Die-cast metal, except at threaded holes for conduit, where a minimum of 6,4 mm thickness is required, shall be:</p> <ul style="list-style-type: none"> • not less than 2,0 mm thick for an area larger than 155 cm² or having any dimension larger than 150 mm; • not less than 1,2 mm thick for an area of 155 cm² or less and having no dimension larger than 150 mm. <p>The area under evaluation may be bounded by reinforcing ribs subdividing a larger area.</p> <p>Malleable iron or permanent-mould cast aluminium, brass, bronze, or zinc, except at threaded holes for conduit, where a minimum of 6,4 mm thickness is required, shall be:</p> <ul style="list-style-type: none"> • at least 2,4 mm thick for an area greater than 155 cm² or having any dimension more than 150 mm; • at least 1,5 mm thick for an area of 155 cm² or less having no dimension more than 150 mm. <p>A sand-cast metal enclosure shall be a minimum of 3,0 mm thick except at locations for threaded holes for conduit, where a minimum of 6,4 mm is required.</p>		N/A
4.12.4/RD	Sheet metal		N/A
4.12.5/RD	Stability test for enclosure		N/A
	<p>Under conditions of normal use, units and equipment shall not become physically unstable to the degree that they could become a hazard to an operator or to a service person.</p> <p>If units are designed to be fixed together on site and not used individually, the stability of each individual unit is exempt from the requirements of 4.12.5/RD.</p> <p>The requirements of 4.12.5/RD are not applicable if the installation instructions for a unit specify that the equipment is to be secured to the building structure before operation.</p> <p>Under conditions of operator use, a stabilizing means, if needed, shall be automatic in operation when drawers, doors, etc., are opened.</p> <p>During operations performed by a service person, the stabilizing means, if needed, shall either be automatic in operation, or a marking shall be provided to instruct the service person to deploy the stabilizing means.</p> <p>Compliance is checked by test of 5.2.2.5/RD.</p>		N/A
4.101	UPS isolation and disconnect device		P
4.101.1	Emergency switching (disconnect) device	<i>Emergency stop circuit provided</i>	P

IEC 62040-1			
Clause	Requirement + Test	Result - Remark	Verdict
4.101.2	Normal disconnect devices		P
4.102	Stored energy source		P
4.102.1	General		P
4.102.2	Accessibility and maintainability		P
4.102.3	Distance between battery cells		P
4.102.4	Case insulation		N/A
4.102.5	Electrolyte spillage	<i>The batteries used are sealed lead-acid, valve-regulated and maintenance-free</i>	N/A
4.102.6	Ventilation and hydrogen concentration		N/A
4.102.7	Charging voltages		P
4.102.8	Battery circuit protection		P
4.102.8.1	Overcurrent and earth fault protection		P
4.102.8.2	Location of protective device		P
4.102.8.3	Rating of protective devices		P
4.103	UPS connection to telecommunication lines		P

5	Test requirements		P
5.1/RD	General		P
5.1.1/RD	Test objectives and classification		P
5.1.2/RD	Selection of test samples		P
5.1.3/RD	Sequence of tests		P
5.1.4/RD	Earthing conditions		P
5.1.5/RD	General conditions for tests		P
5.1.5.1/RD	Application of tests		P
	Unless otherwise stated, upon conclusion of the tests, the equipment need not be operational.		P
5.1.5.2/RD	Test samples		P
5.1.5.3 5.1.5.3/RD	Operating parameters for tests		P
5.1.6/RD	Compliance		P
5.1.7	Test overview		P
5.1.7.101	UPS test overview		P
5.2	Test specification		P
5.2.1/RD	Visual inspections (type test, sample test and routine test)		P

IEC 62040-1			
Clause	Requirement + Test	Result - Remark	Verdict
	Before type testing, a check shall be made that the PECS delivered for the test is as expected with respect to supply voltage, input and output ranges, etc.		P
5.2.2/RD	Mechanical tests		P
5.2.2.1/RD	Clearance and creepage distance test (type test)		P
	It shall be verified by measurement or visual inspection that the clearance and creepage distances comply with 4.4.7.4/RD and 4.4.7.5/RD.		P
	Where this verification is impossible to perform, an impulse voltage test (see 5.2.3.2/RD) shall be performed between the considered circuits.		P
5.2.2.2	Non-accessibility test (type test)		P
5.2.2.3/RD	Ingress protection test (IP rating)(type test)		P
	The claimed IP rating of the enclosure shall be verified. This test shall be performed as a type test of the enclosure of a PSCS as specified in IEC 60529 for the enclosure classification.	<i>IP20</i>	P
5.2.2.4/RD	Enclosure integrity test (type test)		P
5.2.2.4.1 /RD	General		P
	The integrity tests apply to PSCS, and also where PSCS are intended for operation without a further enclosure in restricted access areas. After completion of the integrity test, the PSCS shall pass the tests of 5.2.3.2/RD and 5.2.3.4/RD and shall be inspected to confirm that:		P
	- no degradation of any safety-relevant component of the PSCS has occurred.		P
	- live parts have not become accessible (see 4.4.3.3/RD).		P
	- enclosures show no cracks or openings which could cause a hazard.		P
	- clearances are not less than their minimum permitted values and other insulation is undamaged.		P
	- barriers have not been damaged or loosened.		P
	- no moving parts which could cause a hazard are exposed.		P
	The integrity tests shall be performed at the worst case point on representative accessible face(s) of the enclosure.		P
	The PSCS is not required to be operational after testing and the enclosure may be deformed to such an extent that its original IP rating is not maintained.		P

IEC 62040-1			
Clause	Requirement + Test	Result - Remark	Verdict
5.2.2.4.2 /RD	Deflection test (type test)		P
5.2.2.4.2.1 /RD	General		P
5.2.2.4.2.2 /RD	Stead force test, 30N		P
5.2.2.4.2.3 /RD	Stead force test, 250N		P
5.2.2.4.3 /RD	Impact test (type test)	<i>Metallic enclosure</i>	N/A
5.2.2.4.4	Drop test		N/A
5.2.2.4.5 /RD	Stress relief test		P
5.2.2.5/RD	Stability test		P
5.2.2.6	Wall, ceiling or rack mounted equipment test		N/A
5.2.2.6.101	Wall and ceiling mounted equipment test		N/A
5.2.2.6.102	Rack mounted equipment test		N/A
5.2.2.7/RD	Handle and manual controls securement test		N/A
5.2.2.101	Cord guard test		N/A
5.2.3/RD	Electrical tests		P
5.2.3.1/RD	General		P
	The electrical tests described in 5.2.3.2/RD to 5.2.3.5/RD are applicable to basic, supplementary and reinforced insulation. Before performing these tests, preconditioning according to 5.2.6.3.1/RD and 5.2.6.3.2/RD is required.		P
	When performing electrical and preconditioning tests, the preferred procedure is to test the entire equipment; however it is acceptable to test the components or sub-assemblies providing the basic and reinforced insulation. When components or sub-assemblies are tested, test conditions shall simulate the least favourable conditions occurring inside the equipment at the place of installation.		P
5.2.3.2/RD	Impulse voltage test (type test and sample test)	See Table 4.4.7.10/RD	P
5.2.3.3/RD	Alternative to impulse voltage test (type test and sample test)		N/A
	An a.c. or d.c. voltage test according to 5.2.3.4/RD may be used as an alternative method to the impulse voltage test of 5.2.3.2/RD.		N/A

IEC 62040-1			
Clause	Requirement + Test	Result - Remark	Verdict
	For an a.c. voltage test the peak value of the a.c. test voltage shall be equal to the impulse test of Table 25 and applied for three cycles of the a.c. test voltage.		N/A
	For a d.c. voltage test the average value of the d.c. test voltage shall be equal to the impulse test voltage of Table 25 and applied three times for 10 ms in each polarity.		N/A
	See IEC60664-1 clause 6.1.2.2.2/RD for further information.		N/A
5.2.3.4/RD	Ac or d.c. voltage test (type test and routine test)		P
5.2.3.4.1 /RD	Purpose of test		P
	The test is used to verify that the clearances and solid insulation of components and of assembled PSCS has adequate dielectric strength to resist temporary overvoltage conditions.		P
5.2.3.4.2 /RD	Value and type of test voltage		P
	The values of the test voltage for circuits connected to mains supply are determined from column 2 or 3 of Table 26. The voltage test shall be performed with a sinusoidal voltage at 50 Hz or 60 Hz. If the circuit contains capacitors the test may be performed with a d.c. voltage of a value equal to the peak value of the specified a.c. voltage.		P
5.2.3.4.3 /RD	Performing the voltage test		P
	a) Test (1) between accessible conductive part 8connected to earth) and each circuit sequentially (except DVC As circuits). Test voltage according to Table 26, or Table 27, column 2, corresponding to voltage of considered circuit under test. Test (2) between accessible surface (nonconductive or conductive but not connected to earth9 and each circuit sequentially (except DVC As circuits). Test voltage according to Table 26 or Table 27, column 3 (for type test) or column 2 (for routine test), corresponding to voltage of considered circuit under test.		P

IEC 62040-1			
Clause	Requirement + Test	Result - Remark	Verdict
	b) Test between each considered circuit sequentially and the other adjacent circuits connected together. Test voltage according to Table 26 or Table 27, column 2, corresponding to voltage of considered circuit under test.		P
	c) Test between DVC As circuit and each adjacent circuit sequentially. Test voltage according to Table 26 or Table 27, column 3 (for type test) or column 2 (for routine test), corresponding to the circuit with the higher voltage. Either the adjacent circuit or the DVC As circuit may be earthed for this test. It is necessary to test functional insulation between PELV and SELV circuits, but it is not necessary to test functional insulation between adjacent PELV or adjacent SELV circuits.		P
5.2.3.4.4 /RD	Duration of the a.c. or d.c. voltage test		P
	The duration of the test shall be at least 60 s for the type test and 1 s for the routine test. The test voltage may be applied with increasing and/or decreasing ramp voltage but the full voltage shall be maintained for 60 s and 1 s respectively for type and routine tests.		P
5.2.3.4.5 /RD	Verification of the a.c. or d.c. voltage test		P
	The test is successfully passed if no electrical breakdown occurs during the test.		P
5.2.3.5/RD	Partial discharge test (type test, sample test)		N/A
	The partial discharge test shall confirm that the solid insulation (see 4.4.7.8/RD) used in components and subassemblies for protective separation of electrical circuits remains partial-discharge-free within the specified voltage range (see Table 28).		N/A
	This test shall be performed as a type test and a sample test. It may be omitted for insulating materials which are not degraded by partial discharge, for example ceramics. The partial discharge inception and extinction voltage are influenced by climatic factors (e.g. temperature and moisture), equipment self-heating, and manufacturing tolerance. These influencing variables can be significant under certain conditions and shall therefore be taken into account during type testing.		N/A

IEC 62040-1			
Clause	Requirement + Test	Result - Remark	Verdict
5.2.3.6/RD	Protective impedance test (type test and routine test)		N/A
	<p>A type test shall be performed to verify that the current through a protective impedance under normal operating or single-fault conditions does not exceed the values given in 4.4.3.4/RD. The test shall be performed using the circuit of IEC 60990:1999, Figure 4.</p> <p>NOTE IEC 60990 states that the use of a single network for the measurement of a.c. combined with d.c. has not been investigated, but no suggestion is made for measurement in such cases.</p> <p>The value of the protective impedance shall be verified as a routine test.</p>		N/A
5.2.3.7/RD	Touch current measurement test (type test)		N/A
	The touch current shall be measured to determine if the measures of protection need not be taken (see 4.4.4.3.3/RD). The PECS shall be set up in an insulated state without any connection to the earth and shall be operated at rated voltage. Under these conditions, the touch current shall be measured between the means of connection for the PE conductor and the PE conductor itself with the test circuit of Figure 4 of IEC 60990:1999.		N/A
	<ul style="list-style-type: none"> • For a PSCS to be connected to an earthed neutral system, the neutral of the mains of the test site shall be directly connected to the protective earthing conductor. 		N/A
	<ul style="list-style-type: none"> • For a PSCS to be connected to an earthed neutral system, the neutral shall be connected through a resistance of 1 kΩ to the protective earthing conductor which shall be connected to each input phase in turn. The highest value will be taken as the definitive result. 		N/A
	<ul style="list-style-type: none"> • For a PSCS to be connected to a corner earthed system, the protective earthing conductor shall be connected to each input phase in turn. The highest value will be taken as the definitive result. 		N/A
	<ul style="list-style-type: none"> • For a PSCS with a particular earthing system, this system shall operate as intended during the test. 		N/A
	<ul style="list-style-type: none"> • If a PSCS is intended to be connected to more than one system network, each of these different system networks (or the worst-case, if that can be determined) shall be used to make the touch current measurement. 		N/A
5.2.3.8/RD	Capacitor discharge test (type test)		P

IEC 62040-1			
Clause	Requirement + Test	Result - Remark	Verdict
	The capacitor discharge time as required by 4.4.3.4/RD may be verified by a type test and/or by calculation taking into account the relevant tolerances.		P
5.2.3.9	Limited power source test (type test)		N/A
5.2.3.10 5.2.3.10 /RD	Temperature rise test (type test)		P
	If possible the PECS must operate in the worst conditions of the rated power and the output current.		P
	Equipment, in which the heating or cooling quantity depends on the temperature, the temperature measurement must be carried out under the most unfavourable conditions of ambient temperature within the range specified by the manufacturer.		P
	The PECS shall be tested with at least 1,2 m of wire attached to each field wiring terminal. The wire shall be of the smallest size intended to be connected to the PECS as specified by the manufacturer for installation. When there is only provision for the connection of bus-bars to the PECS, they shall be of the minimum size intended to be connected to the PECS as specified by the manufacturer, and they shall be at least 1,2 m in length.		P
	The test shall be maintained until thermal stabilization has been reached. That is, when three successive readings, taken at intervals of 10 % of the previously elapsed duration of the test and not less than 10 min. intervals, indicate no change in temperature, defined as ± 1 °C between any of the three successive readings, with respect to the ambient temperature.		P
	The temperature of an electrical insulation (other than that of windings) is measured on the surface of the insulation at a point close to the heat source, if a failure of this insulation could cause a hazard. If temperatures of windings are measured by the thermocouple method, the thermocouple shall be located on the surface of the winding assuming the hottest part due to surrounding heat emitting components. See also notes in Table 14.		P
	The maximum temperature attained shall be corrected to the rated ambient temperature of the PSCS by adding the difference between the ambient temperature during the test and the maximum rated ambient temperature.		P
	No corrected temperature of the material or component shall exceed the temperature in Table 14 in IEC 62477-1: 2012 or Table 103 as applicable.		P

IEC 62040-1			
Clause	Requirement + Test	Result - Remark	Verdict
	During the test, thermal cut-out, overload detection functions and devices shall not operate.		P
5.2.3.11 /RD	Protective equipotential bonding tests (type tests and routine test)		P
5.2.3.11.1 /RD	General		P
	<p>Each conductive accessible part under consideration shall be tested separately, to determine if the protective equipotential bonding path for that part is adequate to withstand the test current that the bonding path may be subjected to under fault conditions.</p> <p>The circuit under consideration shall be selected from amongst those circuits adjacent to the accessible part under consideration and separated from it by only basic or functional insulation.</p> <p>All of these selected circuits have to be analysed regarding prospective short circuit current and the associated protective element(s):</p> <ul style="list-style-type: none"> - If the circuit under consideration exceeds the 5 s disconnection time requirement of IEC 60364-4-41, the protective equipotential bonding impedance test of 5.2.3.11.2/RD and the protective equipotential bonding short circuit test of 5.2.3.11.3/RD have to be performed. - If the circuit under consideration meets the 5 s disconnection time requirement of IEC 60364-4-41, the protective equipotential bonding short circuit test of 5.2.3.11.3/RD has to be performed. - If the circuit under consideration meets the disconnection time requirement of IEC 60364-4-41:2005, Table 41.1, as applicable, depending on the earthing system of the installation, no type test is required. 		P
	For pluggable equipment type A only the protective equipotential bonding impedance test of 5.2.3.11.2/RD have to be performed.		N/A
5.2.3.11.2 /RD	Protective equipotential bonding impedance test		P
5.2.3.11.2.1/RD	Test conditions		P

IEC 62040-1			
Clause	Requirement + Test	Result - Remark	Verdict
	<p>Where required by 4.4.4.2.2/RD and 5.2.3.11.2.1/RD, the impedance of protective equipotential bonding means shall be checked by passing a test current through the bond for a period of time. The test current is based on the rating of the overcurrent protection for the equipment or part of the equipment under consideration, as follows:</p> <ul style="list-style-type: none"> • for pluggable equipment type A, the overcurrent protective device is that provided external to the equipment (for example, in the building wiring, in the mains plug or in an equipment rack); • for pluggable equipment type B and permanently connected equipment, the maximum rating of the overcurrent protective device specified in the equipment installation instructions to be provided external to the equipment; • the rating of the provided overcurrent device for a circuit or part of the equipment for which an overcurrent protective device is provided as part of the equipment. 		P
5.2.3.11.2.2/RD	Test current, duration and acceptance criteria		P
	a) For PECS with an overcurrent protective device rating of 16 A or less, this test may be omitted, if an impedance not exceeding 0,1 Ω can be demonstrated.		N/A
	b) As an alternative to Table 29, where the time-current characteristic of the overcurrent protective device that limits the fault current in the protective equipotential bonding means is known because the device is either provided in the equipment or fully specified in the installation instructions, the test duration may be based on that specific device's time-current characteristic. The tests are conducted for a duration corresponding to the 200 % current value on the time-current characteristic.	<i>Input overcurrent protective device rated at 125 A.</i>	P
	c) For PECS with an overcurrent protective device rating of more than 460 A, calculations or simulations according to IEC 60949 shall be used to show the ability of the prospective short circuit current to fulfil the requirements. The protective equipotential bonding continuity routine test of 5.2.3.11.4/RD shall be performed to show that the impedance of the protective equipotential bonding means during and at the end of the test shall not exceed the expected value.		N/A

IEC 62040-1			
Clause	Requirement + Test	Result - Remark	Verdict
	Acceptance criteria: The test current is 200 % of the overcurrent protective device rating and the duration of the test is as shown in Table 29. The voltage drop in the protective equipotential bonding means, during and at the end of the test, shall not exceed DVC As, as determined from Table 2 and Table 5 with respect to the accessible surface of the enclosure.		P
	After the tests, visual inspection shall show no damage to the protective equipotential bonding means.		P
5.2.3.11.3 /RD	Protective equipotential bonding short circuit withstand test (type test)		P
	As required by 5.2.3.11.2.1/RD, the short circuit test in 5.2.4.3/RD shall be performed to ensure that protective bonding has the ability to withstand the prospective short circuit current that it may be subjected to under fault conditions.		P
	The testing shall include an individual test of the protective bonding path for each conductive accessible part unless analysis shows that the short circuit withstand capability of the path is adequate, or that the results of one combination are representative of the anticipated results of another combination.		P
5.2.3.11.4 /RD	Protective equipotential bonding continuity test (routine test)	<i>Routine test</i>	N/A
5.2.3.101	Backfeed protection test (type test)		N/A
5.2.3.101.1	General		N/A
5.2.3.101.2	Test for pluggable UPS		N/A
5.2.3.101.3	Test for permanently connected UPS		N/A
5.2.3.101.4	Method to simulate the load-induced change of reference potential for pluggable UPS		N/A
5.2.3.101.5	Solid-state backfeed protection		N/A
5.2.3.102	Input current test		P
5.2.3.103	Short-time withstand current test (type test)		P
5.2.3.103.1	General procedure		N/A
5.2.3.103.2	Input port rated conditional short-circuit current		N/A
5.2.3.103.3	Input port short-time withstand current rating		N/A
5.2.3.103.4	Exemption from testing	<i>Declared Icc did not exceed 10 kA</i>	P
5.2.3.104	Transformer protection test		P
5.2.3.105	Unsynchronized load transfer test		P

IEC 62040-1			
Clause	Requirement + Test	Result - Remark	Verdict
5.2.3.105.1	General		P
5.2.3.105.2	Phase displacement		P
5.2.4/RD	Abnormal operation and simulated fault tests		P
5.2.4.1 5.2.4.1/RD	General	See table 4.2/RD and 4.3/RD	P
5.2.4.2/RD	Pass criteria		P
	<p>As a result of the abnormal operation tests, the PSCS shall comply with the following:</p> <ul style="list-style-type: none"> - there shall be no emission of flame, burning particles or molten metal; - the surgical cotton indicator shall not have ignited; - the earth connection and protective bonding of the PSCS shall not have opened; - doors and cover shall remain in place; - during and after the test, accessible DVC As, SELV and PELV circuits and accessible conductive parts shall not exhibit voltages greater than the time dependent voltages of Figure 1, Figure 2 or Figure 3, as appropriate and shall be separated from live parts at voltages greater than DVC As with at least basic insulation. Compliance shall be checked by the a.c./d.c. insulation test of 5.2.3.4/RD for basic insulation; - during and after the test, live parts at voltages greater than DVC As shall not become accessible. 		P
	The PSCS is not required to be operational after testing and it is possible that the enclosure can become deformed. Overcurrent protection integral to the PECS, or required to be used with the PECS, is allowed to open.		P
5.2.4.3/RD	Protective equipotential bonding short circuit withstand test (type test)		P
5.2.4.3.1 /RD	General		P
	When required by 5.2.3.11.2.1/RD, a protective bonding path shall be subjected to the following short-circuit withstand test.		P
5.2.4.3.2 /RD	Test conditions		P
	The equipment under test shall be supplied with power and the output port shall be operating as intended in 5.2.4.1/RD prior to closing the switching means that applied will be more severe.		P

IEC 62040-1			
Clause	Requirement + Test	Result - Remark	Verdict
	The protective bonding short circuit test shall be performed with the PSCS working with light load, unless analysis shows that higher short circuit currents are available under higher loading conditions.		P
	A new sample may be used for each short-circuit test.		P
5.2.4.3.3 /RD	Protective equipotential bonding short circuit test method		P
5.2.4.3.4 /RD	Pass criteria		P
5.2.4.4/RD	Output short-circuit test (type test)		P
5.2.4.4.1 /RD	Load condition		P
	The short circuit test shall be performed with the PSCS at full load or light load whichever creates the more severe condition.		P
5.2.4.4.2 /RD	Short-circuit test method		P
	In addition to determining compliance with the criteria of 5.2.4.2/RD, this test is used to determine the output short circuit current rating of the port under consideration, in accordance with 4.3.2.3/RD. An oscilloscope or other suitable instrument shall be used to measure the peak current during the test, and to measure or calculate the r.m.s. value of the current.		P

IEC 62040-1			
Clause	Requirement + Test	Result - Remark	Verdict
	<p>The value(s) to be recorded and to be provided with the PECS instructions, in accordance with 6.2, are the peak current, and the highest of the r.m.s. current values measured or calculated over a time period as follows:</p> <p>a) for a.c. signals, three cycles of the nominal a.c. frequency for the port under consideration, in which case the value is to be stated as the 3-cycle r.m.s. value;</p> <p>b) for all signals, the duration of the short circuit from the time the short circuit is applied, until the time the short circuit current is interrupted by a protective device or other mechanism, in which case the value stated is to include the r.m.s. value and the time period in seconds;</p> <p>c) for short circuit tests that result in a continuous non-zero value, the steady-state r.m.s. value, in which case the value is to be stated as a continuous r.m.s value.</p> <p>For PECS with internal short circuit protection according to 4.3.2.3/RD, which protects the output port within some few μs, the requirements in a), b) and c) are not applicable.</p>		P
5.2.4.5/RD	Output overload test (type test)		P
5.2.4.6/RD	Breakdown of components test (type test)		P
5.2.4.6.1 /RD	Load conditions	See table 4.2/RD and 4.3/RD	P
	The breakdown of a component, identified as a result of the circuit analysis of 4.2/RD, shall be tested with the PSCS at full load or light load whichever creates the more severe condition.		P
5.2.4.6.2 /RD	Application of short circuit or open-circuit		P
	The short circuit shall be applied with cable of a cross-section appropriate for the current that normally flows through the component, but no less than 2.5 mm ² . The length of the loop shall be as short as practical to perform the test. Short circuits and open circuits are applied using an appropriate switching device.		P
	Each identified component shall be subjected to only one breakdown of components test unless both open- and short-circuit failure modes are likely in that component.		P
5.2.4.6.3 /RD	Test sequence		P

IEC 62040-1			
Clause	Requirement + Test	Result - Remark	Verdict
	For the Breakdown of components test, identified components shall be short-circuited or open-circuited, whichever creates the worst hazard, one at a time.		P
5.2.4.7/RD	PWB short circuit test (type test)		N/A
	On PWBs, functional insulation provided by spacings which are less than those specified in Table 10 and Table 11 (see 4.4.7.7/RD) shall be type tested as described below.		N/A
	The decreased spacings shall be short-circuited one at a time, on representative samples, and the short-circuit shall be maintained until no further damage occurs.		N/A
5.2.4.8/RD	Loss of phase test (type test)		P
	A multi-phase PSCS shall be operated with each line (including neutral, if used) disconnected in turn at the input. The test shall be performed by disconnecting one line with the power conversion equipment operating at its maximum normal load and shall be repeated by initially energizing the device with on lead disconnected.		P
	The test shall continue until terminated by a protective mechanism, a component failure occurs, or the temperature stabilizes.		P
	This particular requirement may be simulated for PSCS with rated input current greater than 500 A.		P
5.2.4.9/RD	Cooling failure tests (type tests)		P
5.2.4.9.1 /RD	General and pass criteria		P
	For PSCS having a combination of cooling mechanisms, all relevant tests shall be performed. It is not necessary to perform the tests simultaneously. The test shall continue, - until the temperature stabilizes, in which case the temperature limits of 4.6.4.2/RD apply; or - until terminated by a protective mechanism or a component failure occurs, in which case the temperature limits of 4.6.4.2/RD may be exceeded by not more than 5°C. If this is not possible a warning statement shall be provided in the user documentation.		P
	NOTE The temperature increase of 5 °C with regard to the steady state limits reflect the spread of the burn threshold given in IEC Guide 117.		P
5.2.4.9.2 /RD	Inoperative blower motor test		P

IEC 62040-1			
Clause	Requirement + Test	Result - Remark	Verdict
	A PSCS having forced ventilation shall be operated at rated load with fan or blower motor or motors made inoperative, singly or in combination from a single fault, by physically preventing their rotation.	<i>The equipment stops due to overtemperature of power module</i>	P
5.2.4.9.3 /RD	Clogged filter test		N/A
	Enclosed PSCS having filtered ventilation openings shall be operated with the openings blocked to represent clogged filters. The test shall be performed initially with the ventilation openings blocked 50 %. The test shall be repeated under full blocked condition.		N/A
5.2.4.9.4 /RD	Loss of coolant test		N/A
	A liquid cooled PSCS shall be operated at rated load. Loss of coolant shall be simulated by draining the coolant, blocking the flow or disabling the system coolant pump.		N/A
	If the PSCS is shut down due to the operation of a thermal device located inside the coolant, then the test shall be repeated with the coolant drained out of the system.		N/A
	NOTE: It is presumed that the thermal device will be inoperative if not surrounded by coolant liquid.		N/A
5.2.5/RD	Material tests		N/A
5.2.5.1/RD	General		N/A
	When requested by 4.4.7.8.2/RD, the manufacturer shall test the flammability properties of the materials used for insulating purposes, as defined in 5.2.5.2/RD, 5.2.5.3/RD and 5.2.5.4/RD. When requested by 4.6.3.2/RD the manufacturer shall test the flammability properties of the materials used for fire enclosure, as defined in 5.2.5.5/RD		N/A
5.2.5.2/RD	High current arcing ignition test (type test)		N/A
5.2.5.3/RD	Glow-wire test (type test)		N/A
	The glow-wire test shall be made under the conditions specified in 4.4.7.8.2/RD according to IEC 60695-2-10 and IEC 60695-2-13.		N/A
5.2.5.4/RD	Hot wire ignition test (type test – alternative to glow-wire test)		N/A
5.2.5.5/RD	Flammability test (type test)		N/A
5.2.5.6/RD	Flaming oil test (type test)		N/A
5.2.5.7/RD	Cemented joints test (type test)		N/A

IEC 62040-1			
Clause	Requirement + Test	Result - Remark	Verdict
	<p>When required by 4.4.7.9/RD representative samples of cemented joints providing protection of type 1 or type 2 as defined in IEC 60664-3:2003 shall be tested as a type test as follows.</p> <p>The samples shall be subjected to the conditioning procedure specified in 5.7 of IEC 60664-3:2003, using the following parameters: for the cold test (5.7.1/RD), a temperature of -25 °C shall be used, and for the rapid change of temperature test (5.7.3/RD): -25 °C to +125 °C.</p> <p>After the conditioning the samples shall pass the following tests in the prescribed order:</p> <ul style="list-style-type: none"> a) The mechanical strength of the joint shall be evaluated by loading the joint using the forces anticipated to be present under normal conditions. There shall be no separation of the parts. b) The insulation resistance between the conductive parts separated by the joint shall be measured according to 5.8.3 of IEC 60664-3:2003. c) Cemented joints shall be treated as to be thin sheet material and shall be tested according 4.4.7.8.3/RD d) The sectioning of the joint shall not show any cracks, voids or separation. 		N/A
5.2.6 5.2.6/RD	Environmental tests (type tests)		P
5.2.6.1/RD	General		P
	Compliance is shown by conducting test of 5.2.6.3/RD, 5.2.6.4/RD, 5.2.6.5/RD and 5.2.6.6/RD according to Table 30 as applicable for the environmental conditions specified by the manufacture.		P
5.2.6.2/RD	Acceptance criteria		P

IEC 62040-1			
Clause	Requirement + Test	Result - Remark	Verdict
	<p>The following acceptance criteria shall be satisfied:</p> <ul style="list-style-type: none"> - no degradation of any safety-relevant component of the PSCS; - no potentially hazardous behaviour of the PSCS during the test; - no sign of component overheating; - no live part shall become accessible; - no cracks in the enclosure and no damaged or loose insulators; - pass routine a.c. or d.c. voltage test 5.2.3.4/RD; - pass protective bonding test 5.2.3.11.2/RD; - no potentially hazardous behaviour when the PSCS is operated following the test. 		P
5.2.6.3/RD	Climatic tests		P
5.2.6.3.1 /RD	Dry heat test (steady state)		P
	To prove the ability of components and equipment to be operated, transported or stored at high temperatures the dry heat (steady state) test shall be performed according to the conditions specified in Table 31.		P
5.2.6.3.2 /RD	Damp heat test (steady state)		P
	To prove the resistance to humidity, the PSCS shall be subjected to a Damp heat test (steady state) according to Table 32.		P
5.2.6.4	Vibration test (type test)		N/A
5.2.6.5	Salt mist test (type test)		N/A
5.2.6.6	Dust and sand test (type test)		N/A
5.2.7/RD	Hydrostatic pressure test (type test and routine test)		N/A

IEC 62040-1			
Clause	Requirement + Test	Result - Remark	Verdict
	<p>For type tests, the pressure inside the cooling system of a liquid cooled PSCS (see 4.7.2.3.3/RD) shall be increased at a gradual rate until a pressure relief mechanism (if provided) operates, or until a pressure of twice the operating value or 1,5 times the maximum pressure rating of the system is achieved, whichever is the greater.</p> <p>NOTE: for the purpose of this test the coolant pump may be disabled.</p> <p>For routine tests, the pressure shall be increased to the maximum pressure rating of the system.</p> <p>The pressure shall be maintained for at least one minute.</p> <p>There shall be no thermal, shock, or other hazard resulting from the test. There shall be no significant leakage of coolant or loss of pressure during the test, other than from a pressure relief mechanism during a type test.</p> <p>After the hydrostatic pressure type test the PSCS shall pass the a.c. or d.c. voltage test 5.2.3.4/RD.</p>		N/A

6	Information and marking requirements		P
6.1	General		P
6.1.101	Durability	<i>No degradation of marking observed</i>	P
6.1.102	Removable parts		P
6.2	Information for selection		P
6.3	Information for installation and commissioning		P
6.3.1/RD	General		P
6.3.2/RD	Mechanical considerations		P
	<p>The following drawings shall be prepared by the manufacturer:</p> <ul style="list-style-type: none"> - Dimensional drawing, including mass information - Mounting drawing 	<i>Information included on user manual and datasheet of equipment</i>	P
6.3.3/RD	Environment		
	In accordance with 4.9/RD the following environmental conditions shall be specified, for operation, transportation and storage:		P
	Climatic (temperature, humidity, altitude, pollution, ultra-violet light, etc.)		P
	Mechanical (vibration, shock, drop, topple, etc.)		P
	Electrical (overvoltage category)		P

IEC 62040-1			
Clause	Requirement + Test	Result - Remark	Verdict
6.3.4/RD	Handling and mounting		P
	In order to prevent injury or damage, the installation documents shall include warnings of any hazards which can be experienced during installation. Where necessary, instructions shall be provided for: <ul style="list-style-type: none"> - packing and unpacking; - moving; - lifting; - strength and rigidity of mounting surface; - fastening; - provision of adequate access for operation, adjustment and maintenance. 		P
6.3.5/RD	Enclosure temperature		N/A
	When surface temperatures of the PECS, close to mounting surfaces, exceed the limit of 4.6.4.2/RD, the installation manual shall contain a warning to consider the combustibility of the mounting surface.		N/A
	Where required by 4.6.3.1/RD, the following marking shall appear on the PECS and in the installation instructions: "suitable for mounting on concrete or other non-combustible surfaces only".		N/A
6.3.6/RD	Connections		P
6.3.6.1/RD	General		P
	Information shall be provided to enable the installer to make safe electrical connection to the PSCS. This shall include information for protection against hazards (for example, electric shock or availability of energy) that may be encountered during installation, operation or maintenance.		P
6.3.6.2/RD	Interconnection and wiring diagrams		P
	The installation and maintenance manuals shall include details of all necessary connections, together with a suggested interconnection diagram.		P
6.3.6.3/RD	Conductor (cable)selection		P
	The Installation manual shall define the voltage and current levels for all connections to the PSCS, together with cable insulation requirements. These shall be worst-case values, taking into account overcurrent and overload conditions and the possible effects of non-sinusoidal currents.		P
6.3.6.4/RD	Terminal capacity and identification		P

IEC 62040-1			
Clause	Requirement + Test	Result - Remark	Verdict
	The installation and maintenance manuals shall indicate the range of acceptable conductor sizes and types (solid or stranded) for all terminals, and also the maximum number of conductors which can simultaneously be connected.		P
	For field wiring terminals, the manuals shall specify the requirements for tightening torque values and also the insulation temperature rating requirements for the conductor or cable.		P
	The identification of all field wiring terminals shall be marked on the PSCS, either directly or by label attached close to the terminals.		P
	The installation and maintenance manuals shall identify all external terminals relating to circuits protected by one of the methods of 4.4.6.4/RD.		P
6.3.7/RD	Protection requirements		P
6.3.7.1/RD	Accessible parts and circuits		P
	The installation, users and maintenance manuals shall identify any accessible parts at voltages greater than DVC As, and shall describe the insulation and separation provisions required for protection.		P
	The manuals shall also indicate the precautions to be taken to ensure that the safety of DVC As connections maintained during installation.		P
	Where a hazard is present after the removal of a cover, a warning label shall be placed on the equipment. The label shall be visible before the cover is removed.		P
	The manual of a PSCS shall state the maximum voltage allowed to be connected to each port.		P
	The manuals shall provide instructions for the use of PELF circuits within a zone of equipotential bonding.		N/A
6.3.7.2/RD	Type of electrical supply system		P
	The installation manual or the PECS shall specify requirements for safe earthing including the permitted earthing system of the installation (see 4.4.7.1.4/RD)		P
	The unacceptable earthing systems shall be indicated as: - not permitted; or - with modification of values and/or safety levels which shall be quantified through type test.		N/A
6.3.7.3/RD	Protective class		P

IEC 62040-1			
Clause	Requirement + Test	Result - Remark	Verdict
6.3.7.3.1 /RD	General		P
	The installation manual of the PECS shall declare the protective class specified for the PECS and the product shall be marked according to the requirement of 6.3.7.3.2/RD, 6.3.7.3.3/RD, and 6.3.7.3.4/RD		P
6.3.7.3.2 /RD	Protective class I equipment		P
	Terminals for connection of the PE conductor shall be clearly and indelibly marked with one or more of the following:		P
	The symbol IEC 60417-5019 (2011-01)		P
	With the letters PE		N/A
	The colour coding green or green-yellow		N/A
6.3.7.3.3 /RD	Protective class II equipment		N/A
	Equipment of protective class II shall be marked with symbol IEC 60417-5172 (2011-01) (see Annex C). Where such equipment has provision for the connection of an earthing conductor for functional reasons (see 4.4.6.3/RD) it shall be marked with symbol IEC 60417-5018 (2011-01) (see Annex C).		N/A
6.3.7.3.4 /RD	Protective class III equipment		N/A
	No marking is required on the product.		N/A
6.3.7.4/RD	Touch current marking		N/A
	Where the touch current in the PE conductor exceeds the limits given in 4.4.4.3.3/RD, this shall be stated in the installation and maintenance manuals. In addition, a warning symbol ISO 7010-W001 (2011-06) (see Annex C) shall be placed on the product, and a notice shall be provided in the installation manual to instruct the user that the minimum size of the PE conductor shall comply with the local safety regulations for high PE conductor current equipment.		N/A
6.3.7.5/RD	Compatibility with RCD marking		N/A

IEC 62040-1			
Clause	Requirement + Test	Result - Remark	Verdict
	The installation and maintenance manuals shall indicate compatibility with RCDs (see 4.4.8/RD). When 4.4.8/RD b) applies, a caution notice and the symbol ISO 7010-W001 (2011-06) (see Annex C) shall be provided in the user manual, and the symbol shall be placed on the product. The caution notice shall be the following or equivalent: "This product can cause a d.c. current in the PE conductor. Where a residual current-operated protective device (RCD) is used for protection against electrical shock, only an RCD of Type B is allowed on the supply side of this product." (See 6.4.3/RD for general requirements for labels, signs and signals.)		N/A
6.3.7.6/RD	Cable and connection		P
	Any particular cable and connection requirements shall be identified in the installation and maintenance manuals.		P
6.3.7.7/RD	External protection devices		P
	Where external devices are necessary to protect against hazards, the installation manual shall specify the required characteristics (see also 5.2.4/RD and 4.3.2.1/RD)	<i>Back feed protection required in installation</i>	P
6.3.8/RD	Commissioning		N/A
	If commissioning tests are necessary to ensure the electrical and thermal safety of a PSCS, information to support these tests shall be provided for each part of the PSCS. This information can depend on the specific installation, and close cooperation between manufacturer, installer, and user can be required. Commissioning information shall include references to hazards that might be encountered during commissioning, for example those mentioned in 6.4/RD and 6.5/RD.		N/A
6.3.101	Guidance on UPS installation		P
6.4	Information for use		P
6.4.1/RD	General		P
	The user's manual shall include all information regarding the safe operation of the PSCS. In particular, it shall identify any hazardous materials and risks of electrical shock, overheating, misuse of the PSCS.		P
	The manual should also indicate any hazards which can result from reasonably foreseeable misuse of the PSCS.		P
6.4.2/RD	Adjustment		P

IEC 62040-1			
Clause	Requirement + Test	Result - Remark	Verdict
	The user's manual shall give details of all safety-relevant adjustments intended for the user. The identification or function of each control or indicating device and fuse shall be marked adjacent to the item. Where it is not possible to do this on the product, the information shall be provided pictorially in the manual.		P
	Maintenance adjustments may also be described in this manual, but shall be made clear that they should only be made by qualified personnel.		P
	Clear warnings shall be provided where excessive adjustment could lead to a hazardous state of the PSCS.		P
	Any special equipment necessary for making adjustments shall be specified and described.		N/A
6.4.3 6.4.3/RD	Labels, signs and signals		P
6.4.3.1/RD	General		P
	<p>Labelling shall be in accordance with good ergonomic principles so that notices, controls, indications, test facilities, fuses, etc., are sensibly placed and logically grouped to facilitate correct and unambiguous identification.</p> <p>All safety related equipment labels shall be located so as to be visible after installation or readily visible by opening a door or removing a cover.</p> <p>Where a symbol is used, the information provided with the PSCS shall contain an explanation of the symbol and its meaning.</p>		P
	<p>Labels shall:</p> <ul style="list-style-type: none"> • wherever possible, use international symbols as given by ISO 3864-1, ISO 7000 or IEC 60417; • if no international symbol is available, be worded in an appropriate language or in a language associated with a particular technical field; • be concise and unambiguous; • be conspicuous, legible and durable; • state the hazards involved and give ways in which risks can be reduced. 		P

IEC 62040-1			
Clause	Requirement + Test	Result - Remark	Verdict
	<p>When instructing the person(s) concerned as to</p> <ul style="list-style-type: none"> • what to avoid: the wording should include “no”, “do not”, or “prohibited”; • what to do: the wording should include “shall”, or “must”; • the nature of the hazard: the wording should include “caution”, “warning”, or “danger”, as appropriate; • the nature of safe conditions: the wording should include the noun appropriate to the safety device. 		P
	Safety signs shall comply with ISO 3864-1.		P
	<p>The signal words indicated hereinafter shall be used and the following hierarchy respected:</p> <ul style="list-style-type: none"> • DANGER to call attention to a high risk, for example: “High voltage”. • WARNING to call attention to a medium risk, for example: “This surface can be hot.” • CAUTION to call attention to a low risk, for example: “Some of the tests specified in this standard involve the use of processes imposing risks on persons concerned.” <p>Danger, warning and caution markings on the PECS shall be prefixed with the word “DANGER”, “WARNING”, or “CAUTION” as appropriate in letters not less than 3,2 mm high. The remaining letters of such markings shall be not less than 1,6 mm high.</p>		P
6.4.3.2/RD	Isolators		N/A
	Where an isolating device is not intended to interrupt load current, a warning shall state: DO NOT OPEN UNDER LOAD.		N/A
	The following requirements apply to any supply isolating device which does not disconnect all sources of power to the PSCS.		N/A
	If the isolating device is mounted in an equipment enclosure with the operating handle externally operable, a warning label shall be provided adjacent to the operating handle stating that it does not disconnect all power to the PSCS.		N/A
	Where a control circuit disconnecter can be confused with power circuit disconnectors due to size or location, a warning label shall be provided adjacent to the operating handle of the control disconnecter stating that it does not disconnect all power to the PSCS.		N/A
6.4.3.3/RD	Visual and audible signals		P

IEC 62040-1			
Clause	Requirement + Test	Result - Remark	Verdict
	<p>Visual signals such as flashing lights, and audible signals such as sirens, may be used to warn of an impending hazardous event such as the driven equipment start-up and shall be identified.</p> <p>It is essential that these signals:</p> <ul style="list-style-type: none"> - are unambiguous; - can be clearly perceived and differentiated from all other signals used; - can be clearly recognized by the user; - are emitted before the occurrence of the hazardous event. <p>It is recommended that higher frequency flashing lights be used for information.</p> <p>Note: IEC 60073 provides guidance on recommended flashing rates and on/off ratios.</p>		P
6.4.3.4/RD	Hot surfaces		N/A
	Where required by 4.6.4.2/RD the warning symbol W017 of ISO 7010 shall be marked on or adjacent to parts exceeding the touch temperature limits of Table 15.		N/A
6.4.3.5/RD	Control and device marking		P
	<p>The Identification of each control or indicating device and fuse shall be marked adjacent to the item. Replaceable fuses shall be marked with their rating and time characteristics. Where it is not possible to do this on the product, the information shall be provided pictorially in the manual.</p> <p>Appropriate identification shall be marked on or adjacent to each movable connector.</p> <p>Test points shall be individually marked with the circuit diagram reference.</p> <p>The polarity of any polarized devices shall be marked adjacent to the device.</p> <p>The diagram reference and if possible the function shall be marked adjacent to each pre-set control in a position where it is clearly visible while the adjustment is being made.</p>		P
6.4.3.101	Distribution-related backfeed		P
6.4.3.102	Protection in building installation		P
6.4.3.102.1	General	<i>Icc rated equal than 10kA</i>	N/A
6.4.3.102.2	Rated conditional short-circuit current (Icc)		N/A
6.4.3.102.3	Prospective short-circuit current (Icp)		N/A
6.4.3.102.4	Requirement for building installation		N/A

IEC 62040-1			
Clause	Requirement + Test	Result - Remark	Verdict
6.4.3.103	Batteries installed within the UPS enclosure	<i>Battery maintenance should not be performed by an ordinary person</i>	N/A
6.5	Information for maintenance		P
6.5.1/RD	General		P
	The PECS shall be marked with the date code, or serial number from which the date of manufacture can be determined.		P
	Safety information shall be provided in the installation and maintenance manuals including appropriate, the following:		P
	• Preventive maintenance procedures and schedules		P
	• Safety precautions during maintenance		P
	• Location of live parts that can be accessible during maintenance (for example, when covers are removed)		P
	• Adjustment procedures		P
	• Subassembly and component repair and replacement procedures		P
	• Any other relevant information		P
6.5.2/RD	Capacitor discharge		P
	When the requirements 4.4.9/RD are not met, the warning symbol W012 of ISO 7010 and an indication of the discharge time (for example, 45 s, 5 min) shall be placed in a clearly visible position on the enclosure, the capacitor protective barrier, or at a point close to the capacitor(s) concerned (depending on the construction). The symbol shall be explained and the time required for the capacitors to discharge after the removal or the power from the PSCS shall be stated in the installation and maintenance manuals.		P
6.5.3/RD	Auto restart/bypass connection		P
	If a PSCS can be configured to provide automatic restart or bypass connection, the installation, user and maintenance manuals shall contain appropriate warning statements.		P
	A PSCS which is set to provide automatic restart or bypass connection, after the removal of power, shall be clearly identified at the installation.		P
6.5.4/RD	Other hazards		P

IEC 62040-1			
Clause	Requirement + Test	Result - Remark	Verdict
	The manufacturer shall identify any components and materials of a PSCS which require special procedures to prevent hazards.		P
6.5.5/RD	Equipment with multiple sources of supply		P
	In accordance with 4.8/RD, where there is more than one source of supply energizing the PSCS, information shall be provided to indicate which disconnect device or devices are required to be operated in order to completely isolate the equipment.		P
6.5.101	Battery information for maintenance		P
6.5.101.1	Labelling on battery		P
6.5.101.2	Information in instruction manual(s)		P
6.5.101.2.1	General		P
6.5.101.2.2	Instructions for battery replacement	<i>Battery maintenance should not be performed by an ordinary person</i>	N/A

Annex A	Addition information for protection against electric shock		P
A.1/RD	General		P
A.2/RD	Protection by means of DVC As		P
A.3/RD	Protection by means of protective impedance		P
A.4/RD	Protection by using limited voltages		P
A.5/RD	Evaluation of working voltage and selection of DVC for touch voltage, PELV and SELV circuits		P
A.5.1/RD	General		P
A.5.2/RD	Selection of DVC for touch voltage sets to protect against ventricular fibrillation		P
A.5.3/RD	Selection of DVC for touch voltage sets to protect against muscular reaction		P
A.5.4/RD	Selection of DVC for touch voltage sets to protect against startle reaction		P
A.5.5/RD	Determination of voltage limits for touch voltage under fault condition depending on protective equipotential bonding impedance		P
A.5.6/RD	Touch time- d.c. voltage zones of ventricular fibrillation		P
A.5.7/RD	Touch time- d.c. voltage zones of muscular reaction (inability to let go reaction)		P
A.5.8/RD	Touch time- d.c. voltage zones of saltwater-wet skin condition		P

IEC 62040-1			
Clause	Requirement + Test	Result - Remark	Verdict
A.5.9/RD	Touch time- a.c. voltage zones of ventricular fibrillation		P
A.5.10/RD	Touch time- a.c. voltage zones of muscular reaction (inability to let go reaction)		P
A.5.11/RD	Touch time- a.c. voltage zones for startle reaction		P
A.6/RD	Evaluation of the working voltage of circuits		P
A.6.1/RD	General		P
A.6.2/RD	AC working voltage		P
A.6.3/RD	DC working voltage		P
A.6.4/RD	Pulsating working voltage		P
A.7/RD	Examples of the use of elements of protective measures		P
A.101	Comparison of limits of working voltage		P

Annex D	Evaluation of clearance and creepage distances		P
D.1/RD	Measurement		P
D.2/RD	Relationship of measurement to pollution degree		P
D.3/RD	Examples		P

Annex F	Clearance and creepage distance determination for frequencies greater than 30kHz		P
F.1/RD	General influence of the frequency on the withstand characteristics		P
F.2/RD	Clearance		P
F.2.1/RD	General		P
F.2.2/RD	Clearance for inhomogeneous fields		N/A
F.2.3/RD	Clearance for approximately homogenous fields		P
F.3/RD	Creepage distance		P
F.4/RD	Solid insulation		P
F4.1/RD	General		P
F4.2/RD	Approximately uniform field distribution without air gaps or voids		P
F4.3/RD	Other cases		P

Annex BB	Reference loads		P
BB.1	General		P
BB.2	Reference resistive load		P

IEC 62040-1			
Clause	Requirement + Test	Result - Remark	Verdict
BB.3	Reference inductive-resistive loads		N/A
BB.4	Reference capacitive-resistive loads		N/A
BB.5	Reference non-linear load		N/A
BB.5.1	General		N/A
BB.5.2	Test method		N/A

Annex CC	Ventilation of lead-acid battery compartments		P
CC.1	General		P
CC.2	Normal conditions		P
CC.3	Blocked conditions		P
CC.4	Overcharge conditions		N/A

Annex GG	Requirements for the mounting means of rack-mounted equipment		N/A
GG.1	General		N/A
GG.2	Mechanical strength test, variable force		N/A
GG.3	Mechanical strength test, 250N force, including end stops		N/A
GG.4	Compliance		N/A

IEC 62040-1			
Clause	Requirement + Test	Result - Remark	Verdict

4.2/RD to 4.3/RD	TABLE: fault condition tests						P
	ambient temperature (°C)					21,8-24,9	p
No.	component No.	fault	test voltage (V)	test time	fuse No.	fuse current (A)	result
1	--	Phase – Neutral short-circuit	400	<5s	--	--	The equipment limit overcurrent and stop operation
2	--	Phase – Phase short-circuit	400	<5s	--	--	The equipment limit overcurrent, change to bypass mode, trip input circuit breaker and stop operation
3	--	Phase – Phase short-circuit	400	<5s	--	--	The equipment limit overcurrent and stop operation
4	C1 (BM687)	Bus capacitor short-circuit	400	<5s	FS1	80	The equipment stop operation and change to bypass mode. Input fuse of Phase R actuates.
5	Q1 (BM688D00)	IGBT short-circuit (collector-emitter)	400	<5s	FS1	80	Input fuse of Phase R actuates. The equipment stop operation and show error.
6	--	Loss of phase	400	<5s	--	--	All active conductor disconnected consecutively. In operation, the equipment stops immediately and show error. When the fault is applied before starting the equipment show error and it does not start the operation.
7	--	Output overload	400	<10 min	--	--	The equipment stops the operation and change to bypass mode. The time to stops depends of level of overload, times between 10 minutes to 1 seconds
8	--	Fan locked	400	<5 min	--	--	The equipment stops when the temperature of IGBT reach 90°C
9	--	Phase displacement 120°	400	<5 min	--	--	The equipment synchronize with the reference and it does not generate any safety risk
Supplementary information:							

IEC 62040-1			
Clause	Requirement + Test	Result - Remark	Verdict

4.3.101, 5.2.3.102		TABLE: Electrical Data (in normal conditions)					P
fuse #	I rated (A)	U (V)	P (W)	I (mA)	I fuse (mA)	condition/status	
--	79	400	41433	60,2 A	--	Without battery. Frequency 50Hz	
--	79	400	41412	60,2 A	--	Without battery. Frequency 60Hz	
--	83	380	41522	63,1 A	--	Without battery. Frequency 50Hz	
--	83	380	41759	63,4 A	--	Without battery. Frequency 60Hz	
--	76	415	41444	57,8 A	--	Without battery. Frequency 50Hz	
--	76	415	41519	57,8 A	--	Without battery. Frequency 60Hz	
--	83	380	43314	65,8 A	--	Charging battery. Frequency 50Hz	
--	83	380	43190	65,6 A	--	Charging battery. Frequency 60Hz	
--	79	400	43007	62,5 A	--	Charging battery. Frequency 50Hz	
--	79	400	43055	62,6 A	--	Charging battery. Frequency 60Hz	
--	76	415	42891	59,8 A	--	Charging battery. Frequency 50Hz	
--	76	415	42956	59,8 A	--	Charging battery. Frequency 60Hz	
Supplementary information:							

4.4.4.3.3 /RD		TABLE: Touch current measurement			N/A
Measured between:	Measured (mA)	Limit (mA)	Comments/conditions		

IEC 62040-1			
Clause	Requirement + Test	Result - Remark	Verdict
Supplementary information:			

IEC 62040-1			
Clause	Requirement + Test	Result - Remark	Verdict

4.4.7/RD		TABLE: Transformers						P
Loc.	Tested insulation	Working voltage peak / V	Working voltage rms / V	Required electric strength	Required clearance / mm	Required creepage distance / mm	Required distance thr. insul.	
BM693D 00 (BCK320 1-107)	Basic	71 V	50 V	1250 V	0,2	1,2	At least two layers	
Loc.	Tested insulation			Test voltage/ V	Measured clearance / mm	Measured creepage dist./ mm	Measured distance thr. insul. / mm; number of layers	
<u>BM693D</u> <u>00</u>	Basic			1250 V	21,45	21,45	0,06 / 2 layers	
Supplementary information:								

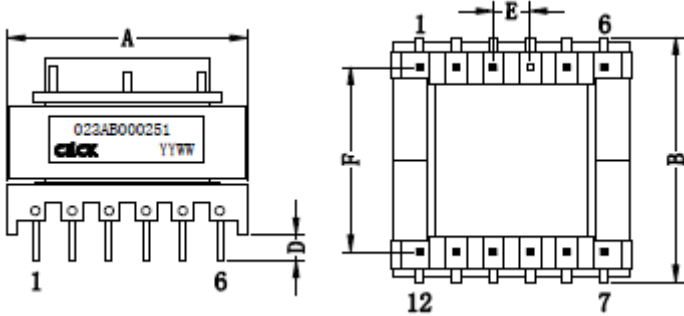
4.4.7/RD		TABLE: Transformers						P
 <p>DIMENSION (mm) : A:33.5 MAX B:34.5 MAX C:25.0 MAX D:3.5±0.5 E:5.0±0.3 F:25.0±0.5 G:SQ 0.8*0.8 ±0.1</p> <p>Trasformer BCK3201-107</p>								

4.4.7.2/RD		TABLE: Working Voltage Measurement			P
Location	RMS voltage (V)	Peak voltage (V)	Comments		
AC circuit	415	587			
BUS circuit	330	330			
Batteries circuit	330	330			
Supplementary information:					

IEC 62040-1			
Clause	Requirement + Test	Result - Remark	Verdict

4.4.7.4/RD to 4.4.7.5/RD	TABLE: Clearance and Creepage Distance Measurements						P
clearance cl and creepage distance dcr at/of:	Up (V)	U r.m.s. (V)	Required cl (mm)	cl (mm)	required dcr (mm)	dcr (mm)	
Board BM696A00							
Batteries – Earth	165	165	0,57	3,32	0,63	3,32	
Batteries (+) – Battery (N)	165	165	0,57	4,91	0,63	4,91	
Batteries (+) – Battery (-)	330	330	0,57	9,92	2,0	9,92	
Board BM711B00							
AC – ELV	339	240	1,71	4,10	1,71	4,10	
AC – Earth	339	240	1,71	7,43	1,71	7,43	
AC (between phases)	587	415	1,71	5,80	2,5	5,80	
Board BM711B00							
BUS – Earth	165	165	0,57	4,48	0,63	4,48	
Batteries – Earth	165	165	0,57	33,29	0,63	33,29	
BUS – ELV	165	165	0,57	4,15	0,63	4,15	
Batteries – ELV	165	165	0,57	7,02	0,63	7,02	
Batteries (+) – Battery (N)	165	165	0,57	4,05	0,63	4,05	
Batteries (+) – Battery (-)	330	330	0,57	6,39	2,0	6,39	
Bus (+) – Bus (N)	165	165	0,57	4,35	0,63	4,35	
Bus (+) – Bus (-)	330	330	0,57	13,04	2,0	13,04	
Board BM687A00							
Bus (+) - Inverter	339	240	1,71	4,02	1,71	4,02	
Board BM688D00							
Inverter - ELV	420	420	1,82	6,28	2,5	6,28	
Board BM690D00							
Rectifier – ELV	420	420	1,71	4,38	2,5	4,38	
Board BM686D00							
BUS – ELV	165	165	0,57	4,01	0,63	4,01	
Bus (+) – Bus (-)	330	330	0,57	8,43	3,3	8,43	
Board BM585A00							
AC (between phases)	587	415	1,71	4,88	2,5	4,88	
AC – Earth	339	240	1,71	6,00	1,71	6,00	
Board BM716A00							
Inverter (between poles)	587	415	1,71	4,13	2,5	4,13	

IEC 62040-1			
Clause	Requirement + Test	Result - Remark	Verdict
Supplementary information: <i>limits applied for OVCI, PD 2 and altitude up to 3000 m</i>			

IEC 62040-1						
Clause	Requirement + Test	Result - Remark				Verdict
4.4.7.4/RD to 4.4.7.5/RD	TABLE: Clearance and Creepage Distance Measurements					P
clearance cl and creepage distance dcr at/of:	Up (V)	U r.m.s. (V)	Required cl (mm)	cl (mm)	required dcr (mm)	dcr (mm)
Board BM584B00						
AC (between phases)	587	415	1,71	4,91	2,5	4,91
AC – Earth	339	240	1,71	5,08	1,71	5,08
Board BM637B00						
AC – ELV	339	240	11,71	4,13	1,5	4,13
Board BM694D00						
ELV – SELV	<50	<50	0,23	8,56	1,2	8,56
Board BM559A00						
AC (between phases)	587	415	1,71	5,12	2,5	5,12
AC – Earth	339	240	1,71	5,11	1,71	5,11
Board BM639C00						
ELV – SELV	<50	<50	0,23	8,09	1,2	8,84
Board BM684C00						
AC – Earth	339	240	1,71	5,99	1,71	5,99
AC (between phases)	587	415	1,71	4,01	2,5	4,01
AC – ELV	339	240	1,71	5,37	1,71	5,37
Board BM691B00						
AC – Earth	339	240	1,71	4,04	1,71	4,04
AC – ELV	339	240	1,71	4,07	1,71	4,07
AC (between phases)	587	415	1,71	4,09	2,5	4,09
Board BM685D00						
BUS – ELV	165	165	0,57	4,20	0,63	4,20
BUS – Earth	165	165	0,57	4,08	0,63	4,08
AC – ELV	339	240	1,71	4,11	1,71	4,11
AC – Earth	339	240	1,71	4,77	1,71	4,77
AC (between phases)	587	415	1,71	4,92	2,5	5,27
Batteries (between poles)	330	330	0,57	6,57	2,0	6,57
Bus (between poles)	330	330	0,57	8,30	2,0	8,45
Supplementary information: <i>limits applied for OVCII, PD 2 and altitude up to 3000 m</i>						

IEC 62040-1			
Clause	Requirement + Test	Result - Remark	Verdict

4.4.7.4/RD to 4.4.7.5/RD	TABLE: Clearance and Creepage Distance Measurements						P
clearance cl and creepage distance dcr at/of:	Up (V)	U r.m.s. (V)	Required cl (mm)	cl (mm)	required dcr (mm)	dcr (mm)	
Board BM693D00							
AC – SELV	339	240	1,71	8,91	1,71	8,91	
Batteries – SELV	165	165	0,57	5,44	0,63	8,80	
BUS – SELV	165	165	0,57	5,44	0,63	8,80	
AC – Earth	339	240	1,71	6,33	1,71	6,33	
Batteries – Earth	165	165	0,57	4,24	0,63	4,24	
BUS – Earth	165	165	0,57	4,24	0,63	4,24	
Bus (between poles)	330	330	0,57	8,54	2,0	8,54	
AC – BUS	339	240	1,71	5,13	1,71	5,13	
Input							
AC (between phases)	587	415	1,71	14,93	2,5	14,93	
AC – Earth	339	240	1,71	22,61	1,71	29,45	
Output							
AC (between phases)	587	415	1,71	14,33	2,5	14,33	
AC – Earth	339	240	1,71	22,11	1,71	33,19	
Supplementary information: <i>limits applied for OVCII, PD 2 and altitude up to 3000 m</i>							

4.4.7.8.2 /RD	TABLE: Ball Pressure Test of Thermoplastics			N/A
Allowed impression diameter (mm)			—	
Object/ Part No./ Material	Manufacturer/ trademark	Test temperature (°C)	Impression diameter (mm)	
Supplementary information:				

IEC 62040-1			
Clause	Requirement + Test	Result - Remark	Verdict

4.4.7.8.2 /RD	TABLE: Resistance to heat and fire - Glow wire tests							N/A
Object/ Part No./ Material	Manufacturer / trademark	Glow wire test (GWT); (°C)						Verdict
		550	650		750		850	
			te	ti	te	ti		
Object/ Part No./ Material	Manufacturer / trademark	Glow-wire flammability index (GWFI), °C				GW ignition temp. (GWIT), °C		Verdict
		550	650	750	850	675	775	
The test specimen passed the glow wire test (GWT) with no ignition [(te – ti) ≤ 2s] (Yes/No) :								
If no, then surrounding parts passed the needle-flame test of annex E (Yes/No)..... :								
The test specimen passed the test by virtue of most of the flaming material being withdrawn with the glow-wire (Yes/No)? :								
Ignition of the specified layer placed underneath the test specimen (Yes/No)..... :								
Supplementary information: 550 °C GWT not relevant (or applicable) to parts of material classified at least HB40 or if relevant HBF The GWIT pre-selection option, the 850 °C GWFI pre-selection option, and the 850 °C GWT are not relevant (or applicable) for attended appliances.								

4.4.7.8.3.2 /RD to 4.4.7.9/RD	TABLE: Distance Through Insulation Measurements				N/A
Distance through insulation di at/of:	U r.m.s. (V)	Test voltage (V)	Required di (mm)	di (mm)	
Supplementary information:					

IEC 62040-1			
Clause	Requirement + Test	Result - Remark	Verdict

4.4.7.10 /RD, 5.2.3/RD	TABLE: electric strength measurements, impulse voltage test and partial discharge test				P
test voltage applied between:	test voltage (V)	impulse withstand voltage (V)	partial discharge extinction voltage (V)	Breakdown / flashover (Yes/No)	
Input to Earth	2050 Vdc	2100	N/A	No	
Output to Earth	2050 Vdc	2100	N/A	No	
Input to Accessible part not earthed	4100 Vdc	N/A	N/A	No	
Output to Accessible part not earthed	4100 Vdc	N/A	N/A	No	
Input to SIP/SOP ports	4100 Vdc	N/A	N/A	No	
Output to SIP/SOP ports	4100 Vdc	N/A	N/A	No	
Supplementary information:					

4.4.9/RD	TABLE: Capacitor discharge				P
Condition	τ calculated (s)	τ measured (s)	t u→ 60V (s)	Comments	
Bus capacitor normal stop	--	--	172		
Bus capacitor emergency stop	--	--	177		
Input terminal normal stop	--	--	1,3		
Input terminal normal stop	--	--	1,3		
Output terminal normal stop	--	--	6,8		
Output terminal normal stop	--	--	1,0		
Supplementary information:					

4.6.3/RD	TABLE: Resistance to fire					N/A
Part	Manufacturer of material	Type of material	Thickness (mm)	Flammability class	Evidence	

IEC 62040-1			
Clause	Requirement + Test	Result - Remark	Verdict

4.6.3.3.3 /RD	TABLE: Needle- flame test (NFT)				N/A
Object/ Part No./ Material	Manufacturer/ trademark	Duration of application of test flame (ta); (s)	Ignition of specified layer Yes/No	Duration of burning (tb) (s)	Verdict
Supplementary information: NFT not relevant (or applicable) for Parts of material classified as V-0 or V-1 NFT not relevant (or applicable) for Base material of PCBs classified as V-0 or if relevant VTM-0					

4.6.4/RD	TABLE: Heating Test			P
	Test voltage (V)	380 V / 50 Hz		—
	Ambient (°C)	42,4		—
Thermocouple Locations		Max. temperature measured, (°C)	Max. temperature limit, (°C)	
Input Circuit Breaker		52,5	70	
AC Input Wire		47,2	75	
Battery power wire		43,7	75	
Filter capacitor (C2)		53,6	85	
Bus Capacitor (C2 of L2)		51,6	85	
Battery Fuse (FS3)		45,9	85	
Filter Inductor (L1)		82,2	90	
Filter Fuse (FS3)		70,7	85	
Auxiliary Transformer		53,9	90	
Handle of Input circuit breaker		42,9	70	
Power Coil (L9)		47,0	150	
Battery		44,4	60	
Battery coil (L2)		47,3	90	
Fan (L2)		68,0	90	
Rear enclosure		45,7	65	
Display		45,8	70	
Left side enclosure		42,3	65	
Right side enclosure		42,2	65	
Upper enclosure (over batteries)		43,1	65	
Upper enclosure (over power converter)		43,3	65	
Supplementary information: Equipment tested of 40 kW				

IEC 62040-1			
Clause	Requirement + Test	Result - Remark	Verdict

4.6.4/RD	TABLE: Heating Test		P
	Test voltage (V)	380 V / 60 Hz	—
	Ambient (°C)	42,6	—
Thermocouple Locations	Max. temperature measured, (°C)	Max. temperature limit, (°C)	
Input Circuit Breaker	52,3	70	
AC Input Wire	51,1	75	
Battery power wire	43,6	75	
Filter capacitor (C2)	55,7	85	
Bus Capacitor (C2 of L2)	50,2	85	
Battery Fuse (FS3)	45,7	85	
Filter Inductor (L1)	82,0	90	
Filter Fuse (FS3)	84,1	85	
Auxiliary Transformer	61,4	90	
Handle of Input circuit breaker	45,5	70	
Power Coil (L9)	46,0	150	
Battery	45,1	60	
Battery coil (L2)	47,6	90	
Fan (L2)	66,7	90	
Rear enclosure	45,1	65	
Display	44,7	70	
Left side enclosure	42,0	65	
Right side enclosure	40,9	65	
Upper enclosure (over batteries)	42,7	65	
Upper enclosure (over power converter)	42,1	65	
Supplementary information: Equipment tested of 40 kW			

IEC 62040-1			
Clause	Requirement + Test	Result - Remark	Verdict

4.6.4/RD	TABLE: Heating Test		P
	Test voltage (V)	380 V / 50 Hz	—
	Ambient (°C)	40,0	—
Thermocouple Locations	Max. temperature measured, (°C)	Max. temperature limit, (°C)	
Battery	49,4	60	
AC Input Wire	67,7	75	
Output Circuit Breaker	71,7	70	
Battery power wire	50,4	75	
Filter capacitor (C2)	74,9	85	
Filter Inductor (L3)	122,7	85	
Battery Fuse (FS3)	61,9	85	
Bus Capacitor (C2 of L2)	48,3	85	
Filter Fuse (FS3)	73	85	
Auxiliary Transformer	88,6	90	
Handle of AC Switch	61,8	90	
Power Coil (L9)	143,3	150	
Output terminal	45,1	70	
Battery connector (partial connector)	42,9	70	
Switch of Batteries	49,9	70	
Battery coil (L2)	83,3	90	
Fan (L2)	55,1	90	
Fuse (FS2)	57	85	
Display	49,6	80	
Right side enclosure	50,5	65	
IGBT	65,8	125	
Upper enclosure (over power converter)	53,3	65	
Frontal enclosure	52,4	65	
Rear enclosure	54,2	65	
Supplementary information: Equipment tested of 80 kW (SLC-80-CUBE4)			

IEC 62040-1			
Clause	Requirement + Test	Result - Remark	Verdict

4.6.4/RD	TABLE: Heating test, resistance method					N/A
	Test voltage (V).....:					—
	Ambient, t ₁ (°C).....:					—
	Ambient, t ₂ (°C).....:					—
Temperature rise of winding	R ₁ (Ω)	R ₂ (Ω)	ΔT (K)	Max. dT (K)	Insulation class	
Supplementary information:						

4.6.5/RD	TABLE: Limited power sources					N/A
Component s	Test condition (Single fault)	Uoc (V)	Isc (A)		VA	
			Meas.	Limit	Meas.	Limit
Supplementary information:						

4.12.1/RD, 5.2.2.4.3 /RD	TABLE: Impact Resistance				P
Impacts per surface	Surface tested	Impact energy (Nm)	Comments		
One time	External enclosure	--	No sustenance damage observed		
Supplementary information:					

IEC 62040-1			
Clause	Requirement + Test	Result - Remark	Verdict

Annex CC	TABLE: Ventilation of lead-acid battery compartments	P
The required dimension for the ventilation openings will be calculated with the following formula:		
$A \geq Q/360$ [m ²]		
with $Q = 0.054 * n * I * C$		
where:		
Q : airflow in m ³ /h		
n : number of battery cells		
I : constant factor (0,2A/100Ah for valve regulated lead acid batteries)		
C : is the battery nominal capacity in Ah at the 10h discharge rate		
With the specific data for the UPS the following dimension for the ventilation openings is required:		
n : 594		
C : 4,25		
$A \geq (0.054 * n * 0.2 A/100 Ah * C)/360$		
$A \geq 0,00075$ m ²		
Verdict		
The size of ventilation openings in battery cabinet exceeds the required airflow by far (as well as the UPS).		
Supplementary information:		

IEC 62040-1			
Clause	Requirement + Test	Result - Remark	Verdict

TABLE: Critical components information					P
Object / part No.	Manufacturer/ trademark	Type / model	Technical data	Standard	Mark(s) of conformity ¹⁾
Terminal block (INPUT & OUTPUT)	DINKLE ENTERPRISE	DKB60-04P	600V 65A	ANSI/UL 1059 ANSI/UL 486A-486B ANSI/UL 486E	UL (E102914)
Terminal block (INPUT & OUTPUT)	HOPPY	HP-RT60-11-_P	600V 65A	ANSI/UL 1059 ANSI/UL 486A-486B ANSI/UL 486E	UL (E163737)
Circuit breaker Q1	CHINT	CB-60A	Curve C; 50 A; 240/415 V	EN 60898-1 EN 60898-2	TUV (R 50335297)
Circuit breaker	CHINT	CB-60A	Curve C; 63 A; 240/415 V	EN 60898-1 EN 60898-2	TUV (R 50335297)
Connector	H.JSY	HAY450A(EL4.5) -RT	300VAC 10A	UL 1977	UL (E350702)
Connector	H. JSY	HAY450A(EL4.5) -PT	300VAC 10A	UL 1977	UL (E350702)
Connector	H. JSY	HAY450A(EL4.5) -3R	300VAC 10A	UL 1977	UL (E350702)
Connector	H. JSY	HAY450A(EL4.5) -3R	300VAC 10A	UL 1977	UL (E350702)
Connector Batteries (Red)	ANEN	PA75B2-HF	75A 600V	UL 1977	UL (E319259)
Connector Batteries (Black)	ANEN	PA75B0-HF	75A 600V	UL 1977	UL (E319259)
Connector Batteries (Blue)	ANEN	PA75B6-HF	75A 600V	UL 1977	UL (E319259)
Capacitor C1, C2, C5, C6, C9, C10 C15, C16, C17	KEMET	X2 F861DU225M310	310 Vac; 225pF	ANSI/UL 60384-14	UL(E97797)
	EPCOS	X2 B32923E3225M	320 Vac; 2,2uF	ANSI/UL 60384-14	UL(E97863)
	FARATRONIC	X2 C42Q2225M9F	305 Vac; 2,2uF	ANSI/UL 60384-14	UL(E186600)
	WINDAY ELECTRONIC	X2 SMPXVF225KE 7XXAB2315	310 Vac; 2,2uF	ANSI/UL 60384-14	UL(E302125)
	BM-CAP	X2 1X2H522K310-08	310 Vac; 2,2uF	ANSI/UL 60384-14	UL (E345487)

IEC 62040-1					
Clause	Requirement + Test			Result - Remark	Verdict
Capacitor C3, C7, C11, C13	EPCOS	Y2 B32022A3223M	300 Vac; 22nF	ANSI/UL 60384-14	UL (E97863)
Capacitor C4, C8, C12, C14	EVOX RIFA	Y2 PME271YA4220 MR19T0	300 Vac; 22nF	ANSI/UL 60384-14	UL (E73869)
	ARCOTRONICS (KEMET)	Y2 R413F12200000 M	300 Vac; 22nF	ANSI/UL 60384-14	UL(E97797)
	EPCOS	Y2 B32021A3222M	300 Vac; 22nF	ANSI/UL 60384-14	UL(E97863)
PCB BM584	GANZHOU BANGDE CIRCUIT TECHNOLOGY CO	BD-D (BM584B00)	V-0	ANSI/UL 796	UL(E348757)
	WELL-TECH (HUIZHOU) CIRCUIT CO LTD	WD001 (BM584B00)	V-0	ANSI/UL 796	UL(E363740)
Capacitor C18, C19, C20, C21	VISHAY	Y2 BFC233860104	300 Vac; 100nF	ANSI/UL 60384-14	UL(E354331)
	EPCOS	Y2 B32023A3104M	300 Vac; 0,1uF	ANSI/UL 60384-14	UL(E97863)
	FARATRONIC	Y2 C43Q1104M9S C350	300 Vac; 100nF	ANSI/UL 60384-14	UL (E186600)
PCB BM585	GANZHOU BANGDE CIRCUIT TECHNOLOGY CO	BD-D (BM585A00)	V-0	ANSI/UL 796	UL(E348757)
	WELL-TECH (HUIZHOU) CIRCUIT CO LTD	WD001 (BM585A00)	V-0	ANSI/UL 796	UL(E363740)
Fuse FS1, FS2, FS3, FS4	ADVANCED SURGETECH MATERIALS	HV620.1	6.2X32mm; 1A; 1000V	UL 248-14	UL(E355868)
	HOLLYLAND FUSES	6FF-010H1	6.2X32mm; 1A; 600V	UL 248-14	UL(E156471)
Fuse Holder PF1A, PF1B, PF2A, PF2B, PF3A, PF3B, PF4A, PF4B	KEystone	3529	Ø6.3; 15A	UL 4248-1	UL(E354010)
	FERRAZ SHAWMUT (MERSEN)	K222051	Ø6.3; 15A	UL 4248-1	UL(E52283)
	COOPER BUSSMANN	1A1907-06-R	Ø6.3; 15A	UL 4248-1	UL(E14853)
	LITTELFUSE	10207101009	Ø6.3; 10A	UL 4248-1	UL(E14721)
Connector CN1	CHYAO SHIUNN ELECTRONIC INDUSTRIAL	JS-1120-08	250 Vac; 7A	ANSI/UL 94,	UL(E113875)
	JST	B8P-VH(LF)(SN)	250 Vac; 10A	ANSI/UL 94,	UL(E60389)

IEC 62040-1					
Clause	Requirement + Test			Result - Remark	Verdict
Surge arrester VT1, VT2, VT3, VT4	THINKING ELECTRONIC INDUSTRIAL CO	TVR20431KSY	275 V; 6500A	UL1449	UL (E314979)
	LITTELFUSE	V275LA40BP	275V; 6500A	UL1449	UL (E320116)
	LITTELFUSE	V275LA40AP	275V; 6500A	UL1449	UL (E320116)
	JOYIN CO LTD	20N431K17PU5	275V; 6500A	UL1449	UL (E325508)
	EPCOS	B72220-S0271- K101	275V; 8000A	UL1449	UL (E321126)
PCB BM559	GANZHOU BANGDE CIRCUIT TECHNOLOGY CO	BD-D (BM559A00)	V-0	ANSI/UL 796	UL(E348757)
	WELL-TECH (HUIZHOU) CIRCUIT CO LTD	WD001 (BM559A00)	V-0	ANSI/UL 796	UL(E363740)
Heatsink HST1, HST2, HST3, HST4	THOMAS & BETTS	HEAT SHRINK TUBE DERAY H	600 V;125°C	ANSI/UL 94,	UL (E79546)
	DSG-CANUSA GMBH	HEAT SHRINK TUBE DERAY H	600 V;125°C	ANSI/UL 94,	UL (E107857)
	CHANGYUAN ELECTRONICS GROUP CO LTD	HEAT SHRINK TUBE CB-HFT	600 V;125°C	ANSI/UL 94,	UL(E180908)
Fuse FS1, FS2, FS3, FS4, FS5, FS6	MERSEN	M220903	14X51mm 40A	ANSI/UL 248-1	UL (76491)
	DF ELECTRIC	492023	14X51mm 40A	ANSI/UL 248-1	UL (E477155)
Connector CN14, CN15, CN5, CN45	CHYAO SHIUNN ELECTRONIC INDUSTRIAL	JS-1120-05	250 V; 7A	UL 1977	UL (E113875)
	JST	B5P- VH(LF)(SN)	250 V; 10A	UL 1977	UL (E60389)
Capacitor C1, C2, C3	VISHAY	WYO102MCMB F0KR	250 V; 1nF; X1	ANSI/UL 60384-14	UL (E183844)
PCB BM696	GANZHOU BANGDE CIRCUIT TECHNOLOGY CO	BD-D (BM696A00)	V-0	ANSI/UL 796	UL(E348757)
Fuse FS1, FS2, FS3, FS4, FS5, FS6	MERSEN	W220819 (FR14GR69V32)	14X51 32A; 690 V	ANSI/UL 248-1	UL (E76491)
	DF ELECTRIC	492022	14X51 32A; 690 V	ANSI/UL 248-1	UL (E477155)
PCB BM684	GANZHOU BANGDE CIRCUIT TECHNOLOGY CO	BD-D (BM696A00)	V-0	ANSI/UL 796	UL(E348757)
Fuse FS1, FS2, FS3	MERSEN	J220969 (6,9 gRB 17/80)	17X49; 80A; 690 V	ANSI/UL 248-1	UL (E76491)
	COOPER BUSSMANN	80FE	17X49; 80A; 690V	ANSI/UL 248-1	UL (E91958)
Connector CN15	INDUSTRIAL CO., LTD	2216S-10G-01- F1	250 Vac; 3A	UL 1977	UL (E144392)

IEC 62040-1					
Clause	Requirement + Test			Result - Remark	Verdict
	FCI	71918-210LF	250 Vac; 3A	UL 1977	UL (E66906)
Fuse FS1, FS2, FS3	COOPER BUSSMANN	63FE	63A 17X49 690V	ANSI/UL 248-1	UL (E91958)
Connector CN5	CHYAO SHIUNN ELECTRONIC INDUSTRIAL	JS-1120-08	250 V; 7A	UL 1977	UL (E113875)
	JST	B8P-VH(LF)(SN)	250 V; 10A	UL 1977	UL (E60389)
INDUCTOR L1, L2, L3	DONGGUAN DINGMEI ELECTRONICS CO LTD	NPF226026-47.0UH	47 uH; 250 V; 180 °C	ANSI/UL 1446 ANSI/UL 94, ANSI/UL 746E ANSI/UL 746F ANSI/UL 746A ANSI/UL 746D ANSI/UL 746C ANSI/UL 1446 IEC 62040-1	UL (E85640) UL (E123995) UL (E304477) UL (E75225) Tested with the equipment
PCB BM684	GANZHOU BANGDE CIRCUIT TECHNOLOGY CO	BD-D (BM684C00)	V-0	ANSI/UL 796	UL(E348757)
Connector CN50	BERG	71918-226LF	1500V; 3A	UL 1977	UL (E66906)
	NELTRON INDUSTRIAL CO., LTD	2216S-26G-01-F1	250 Vac; 3A	UL 1977	UL (E144392)
Connector CN51	NELTRON INDUSTRIAL CO., LTD	2216S-16G-01-F1	250 Vac; 3A	UL 1977	UL (E144392)
	FCI	71918-216LF	1500V; 3A	UL 1977	UL (E66906)
Connector CN40, CN49	CHYAO SHIUNN ELECTRONIC INDUSTRIAL	JS-1120-04	250Vac; 7A	UL 1977	UL (E113875)
	JST	B4P-VH(LF)(SN)	250Vac; 10A	UL 1977	UL (E60389)
Connector CN52, CN53, CN54, CN58, CN24, CN25, CN27	CHYAO SHIUNN ELECTRONIC INDUSTRIAL	JS-1001-02	250 Vac; 3A	UL 1977	UL (E113875)
	JST	B2B-XH-A(LF)(SN)	250 Vac; 3A	UL 1977	UL (E60389)
Capacitor C33, C34, C35, C36, C37, C38	EPCOS	B32923C3105M	300V; 1uF	ANSI/UL 60384-14	UL (E97863)
	FARATRONIC	C42Q2105M9S C000	305V; 1uF	ANSI/UL 60384-14	UL (E186600)
Capacitor C1, C2	MURATA	DE2B3KY331K B3BM02F	250V; 330pF	ANSI/UL 60384-14	UL(E37921)
	JUHONG ELE COMPANY	MTOY5P331PK AC250VP7	250V; 330pF	ANSI/UL 60384-14	UL (E253194)
Optocoupler U1	TLP191B	TLP191B	Iso 2500V	UL1577	UL (E67349)

IEC 62040-1					
Clause	Requirement + Test			Result - Remark	Verdict
Inductor L1, L2, L4, L5, L7, L8	VOLTRONIC POWER TECHNOLOGIES	41-110285-00G	298uH; 1500V; 180°C	ANSI/UL 1446 ANSI/UL 94, ANSI/UL 746E ANSI/UL 746F ANSI/UL 746A ANSI/UL 746D ANSI/UL 746C ANSI/UL 1446 IEC 62040-1	UL (E85640) UL (E123995) UL (E304477) UL (E75225) Tested with the equipment
Inductor L3, L6, L9	VOLTRONIC POWER TECHNOLOGIES	41-110287-00G	199uH; 1500V; 180°C	ANSI/UL 1446 ANSI/UL 94, ANSI/UL 746E ANSI/UL 746F ANSI/UL 746A ANSI/UL 746D ANSI/UL 746C ANSI/UL 1446 IEC 62040-1	UL (E85640) UL (E123995) UL (E304477) UL (E75225) Tested with the equipment
Current transformer HCT1, HCT2, HCT3, HCT4, HCT5, HCT6	LEM	HTB 100-TP	15 V; 100A	ANSI/UL 508 CSA-C22.2 No 14	UL (E189713)
PCB BM684	GANZHOU BANGDE CIRCUIT TECHNOLOGY CO	BD-M (BM685D00)	V-0	ANSI/UL 796	UL(E348757)
Connector CN26	NELTRON INDUSTRIAL CO., LTD	2216S-20G-01-F1	250 Vac; 3A	UL 1977	UL (E144392)
	FCI	71918-220LF	1500V; 3A	UL 1977	UL (E66906)
Connector CN12, CN13, CN18, CN19	WURTH ELEKTRONIK	61300211821	250 Vac; 3A	UL 1977	UL (E323964)
Connector CN14, CN15, CN16, CN20, CN21, CN22	WURTH ELEKTRONIK	61300411821	250 Vac; 3A	UL 1977	UL (E323964)
Connector CN17, CN23	WURTH ELEKTRONIK	61301211821	250 Vac; 3A	UL 1977	UL (E323964)
Capacitor C1, C3, C5, C7	VISHAY	WYO472MCMC F0K	250 V; 0,0047uF	ANSI/UL 60384-14	UL (E183844)
	TAISHAN CITY JUHONG ELECTRONICS LTD	MY5V472PMAC 250VP7	250 V; 0,0047uF	ANSI/UL 60384-14	UL (E253194)
Film ISUC1,	KUNZE FOLIEN	CG20	Iso: 5000V; V0	UL 94	UL (E337894)

IEC 62040-1					
Clause	Requirement + Test			Result - Remark	Verdict
ISUC2, ISUC3, ISUC4, ISD9, ISD10, ISD37, ISD38, ISQ1, ISQ2, ISQ3, ISQ4, ISQ13, ISQ14, ISQ15, ISQ16, ISQ17, ISQ18, ISQ31, ISQ32	BERGQUIST	SIL-PAD K10	Iso: 6000V; VTM-0	UL 94	UL (E59150)
PCB BM686	GANZHOU BANGDE CIRCUIT TECHNOLOGY CO	BD-M (BM686D00)	V-0	ANSI/UL 796	UL(E348757)
HEAT SHRINK TUBE HSTD35, HSTD36	THOMAS & BETTS	DERAY H	600 V; 105 °C	UL 224	UL (E79546)
	DSG-CANUSA GMBH	DERAY H	600 V; 125 °C	UL 224	UL (E107857)
	CHANGYUAN ELECTRONICS GROUP CO LTD	CB-HFT	600 V; 125 °C	UL 224	UL (E180908)
Connector CN26	NELTRON INDUSTRIAL CO., LTD	2216S-20G-01-F1	250 Vac; 3A	UL 1977	UL (E144392)
	FCI	71918-220LF	1500V; 3A	UL 1977	UL (E66906)
PCB BM687	GANZHOU BANGDE CIRCUIT TECHNOLOGY CO	BD-M (BM687A00)	V-0	ANSI/UL 796	UL(E348757)
Connector CN3, CN4, CN5, CN7, CN8, CN9, CN10, CN11, CN12	CHYAO SHIUNN ELECTRONIC INDUSTRIAL	JS-1110-04	3A; 250 V; V-0	UL 1977	UL(E113875)
	WURTH ELEKTRONIK	61300411021	3A; 250 V; V-0	UL 1977	UL (E323964)
	GREENCONN CORPORATION	GPHB101-0402AA67R1BA	3A; 250 V; V-0	UL 1977	UL (E221178)
Optocoupler U4, U5, U6	FAIRCHILD	FOD3150	890 Vpeak; 25mA; 150°C	UL 1577	UL (E90700)
	BROADCOM LIMITED (AVAGO)	SMD ACPL-T350-060E	630 Vpeak; 230mA; 175°C	UL 1577	UL (E55361)
Optocoupler U1, U7, U10, U13, U14	FAIRCHILD	FOD817BSD	850 Vpeak; 400mA; 175°C	UL 1577	UL (E90700)
	FAIRCHILD	FOD817BS	850 Vpeak; 400mA; 175°C	UL 1577	UL (E90700)
	COSMO ELECTRONICS CORPORATION	K10104B	50mA; 115°C; 5000 V Isolation	UL 1577	UL (E169586)

IEC 62040-1					
Clause	Requirement + Test			Result - Remark	Verdict
Transformer TX6, TX7	VOLTRONIC POWER TECHNOLOGIES	41-070283-00G	60 Vdc; 0,2 A; 130°C	ANSI/UL 94 ANSI/UL 1694 ANSI/UL 1446 CAN/UL 510A UL 224 IEC 62040-1	UL (E41429) UL (E176101) UL (E165111) UL (E156256) UL (E87039) Tested with the equipment
Transformer TX8, TX9, TX10	VOLTRONIC POWER TECHNOLOGIES	41-070402-00G	60 Vdc; 0,2 A; 130°C	ANSI/UL 94 ANSI/UL 1694 ANSI/UL 1446 CAN/UL 510A UL 224 IEC 62040-1	UL (E41429) UL (E176101) UL (E165111) UL (E156256) UL (E87039) Tested with the equipment
PCB BM688	GANZHOU BANGDE CIRCUIT TECHNOLOGY CO	BD-M (BM688D00)	V-0	ANSI/UL 796	UL(E348757)
Connector CN1, CN2	CHYAO SHIUNN ELECTRONIC INDUSTRIAL	JS-1110-02	7A; 250 V	UL 1977	UL(E113875)
	WURTH ELEKTRONIK	61300211021	3A; 250 V; V-0	UL 1977	UL (E323964)
	GREENCONN CORPORATION	GPHB101- 0402AA67R1BA	3A; 250 V; V-0	UL 1977	UL (E221178)
Connector CN6	CHYAO SHIUNN ELECTRONIC INDUSTRIAL	JS-1110-12	3A; 250 V; V-0	UL 1977	UL(E113875)
	WURTH ELEKTRONIK	61301211021	3A; 250 V; V-0	UL 1977	UL (E323964)
	GREENCONN CORPORATION	GPHB101- 1202AA67R1BA	3A; 250 V; V-0	UL 1977	UL (E221178)
Optocoupler U1, U2, U3	FAIRCHILD	FOD3150	890 Vpeak; 25mA; 150°C	UL 1577	UL (E90700)
	BROADCOM LIMITED (AVAGO)	SMD ACPL- T350-060E	630 Vpeak; 230mA; 175°C	UL 1577	UL (E55361)
Optocoupler U4, U10, U11, U13, U14	FAIRCHILD	FOD817BSD	850 Vpeak; 400mA; 175°C	UL 1577	UL (E90700)
	FAIRCHILD	FOD817BS	850 Vpeak; 400mA; 175°C	UL 1577	UL (E90700)
	COSMO ELECTRONICS CORPORATION	K10104B	50mA; 115°C; 5000 V Isolation	UL 1577	UL (E169586)

IEC 62040-1					
Clause	Requirement + Test			Result - Remark	Verdict
TRANSFORMER TX1, TX2	VOLTRONIC POWER TECHNOLOGIES	41-070283-00G	60 Vdc; 0,2 A; 130°C	ANSI/UL 94 ANSI/UL 1694 ANSI/UL 1446 CAN/UL 510A UL 224 IEC 62040-1	UL (E41429) UL (E176101) UL (E165111) UL (E156256) UL (E87039) Tested with the equipment
TRANSFORMER TX5, TX6, TX7	VOLTRONIC POWER TECHNOLOGIES	41-070402-00G	60 Vdc; 0,2 A; 130°C	ANSI/UL 94 ANSI/UL 1694 ANSI/UL 1446 CAN/UL 510A UL 224 IEC 62040-1	UL (E41429) UL (E176101) UL (E165111) UL (E156256) UL (E87039) Tested with the equipment
PCB BM690	GANZHOU BANGDE CIRCUIT TECHNOLOGY CO	BD-M (BM690D00)	V-0	ANSI/UL 796	UL(E348757)
Relay RY1, RY2, RY3	PANASONIC	AHES3191	35A; 277Vac; coil 12V	UL 508 UL 60947-1 UL 60947-4-1	UL(E43149)
	XIAMEN HONGFA ELECTROACOUSTIC	HF170F/12-2HTF	35A; 277Vac; coil 12V	UL 508 UL 60947-1 UL 60947-4-1	UL(E133481)
Fuse FS1, FS2, FS3	COOPER BUSSMANN	TR/3216FF1-R	32 Vac 50 A	CSA-C22.2 No. 248-1-00 CSA-C22.2 No. 248-1-00	UL(E19180)
	LITTELFUSE	0466001.NR	63 Vac/dc 50 A	CSA-C22.2 No. 248-1-00 CSA-C22.2 No. 248-1-00	UL(E10480)
Connector CN2, CN3	NELTRON INDUSTRIAL CO., LTD	2216S-20G-01-F1	250 Vac; 3A	UL 1977	UL (E144392)
	FCI	71918-220LF	1500V; 3A	UL 1977	UL (E66906)
Connector CN1	NELTRON INDUSTRIAL CO., LTD	2216S-30G-01-F1	250 Vac; 3A	UL 1977	UL (E144392)
	FCI	71918-230LF	3A; 1500V	UL 1977	UL (E66906)
Connector CN4	NELTRON INDUSTRIAL CO., LTD	2516S-10G-F1	250 Vac; 3A	UL 1977	UL (E144392)

IEC 62040-1					
Clause	Requirement + Test			Result - Remark	Verdict
	FCI	75869-101LF	250 Vac; 3A	UL 1977	UL (E66906)
Connector CN5, CN11, CN12, CN13	CHYAO SHIUNN ELECTRONIC INDUSTRIAL	JS-1001-02	250 Vac; 3A	UL 1977	UL (E113875)
	JST	B2B-XH-A(LF) (SN)	250 Vac; 3A	UL 1977	UL (E60389)
Connector CN6	CHYAO SHIUNN ELECTRONIC INDUSTRIAL	JS-1001-03	250 Vac; 3A	UL 1977	UL (E113875)
	CHANGJIANG CONNECTORS	A2501WV-3P	250 Vac; 3A	UL 1977	UL (E326732)
	JST	B3B-XH-A(LF) (SN)	250 Vac; 3A	UL 1977	UL (E60389)
Connector CN10	CHYAO SHIUNN ELECTRONIC INDUSTRIAL	JS-1109-02	250 Vac; 3A	UL 1977	UL (E113875)
	GREENCONN CORPORATION	GPHA101- 0202A001A1BA	250 Vac; 3A	UL 1977	UL (E221178)
Capacitor C89, C91, C97, C99, C105, C107	FARATRONIC	C42Q2105M9S C000	1uF; 305 Vac; 110°C	ANSI/UL 60384-14	UL (E186600)

IEC 62040-1					
Clause	Requirement + Test		Result - Remark		Verdict
Capacitor C5, C18, C31	VISHAY	WYO472MCMC F0K	4700 pF; 440 Vac; 125°C	ANSI/UL 60384-14	UL (E183844)
	TAISHAN CITY JUHONG ELECTRONICS LTD	MY5V472PMAC 250VP7.5D9P (JA)	4700 pF; 440 Vac; 125°C	IEC 60384-14 ANSI/UL 60384-14	CB (DE1-32135) UL (E253194)
Current transformer CT1, CT2, CT3	VOLTRONIC POWER TECHNOLOGIE S	41-020005-00G	230 V; 50 A; 130°C	ANSI/UL 94 ANSI/UL 1694 ANSI/UL 723 ANSI/UL 1446 CAN/UL 510A UL 224 IEC 62040-1	UL (E59481) UL (E201757) UL (E165111) UL (E17385) UL (E180908) UL (E317427) Tested with the equipment
CURRENT TRANSDUCER HCT1, HCT2, HCT3	LEM	HO 120-NP-0100	120 A; 600 Vac; 105°C	UL 508 UL 61010-1 UL 61010-2-201 UL 2367	UL (E189713)
Film ISQ1, ISQ2, ISQ3, ISQ4, ISQ6, ISQ7, ISQ8, ISQ9, ISQ11, ISQ12, ISQ13, ISQ14	KUNZE FOLIEN	CG20	Iso: 5000V; V0	UL 94	UL (E337894)
	BERGQUIST	SIL-PAD K10	Iso: 6000V; VTM-0	UL 94	UL (E59150)
PCB	GANZHOU BANGDE CIRCUIT TECHNOLOGY CO	BD-M (BM691B00)	V-0	ANSI/UL 796	UL(E348757)
Current transformer CT1, CT2, CT3	VOLTRONIC POWER TECHNOLOGIES	41-020005-00G	230 V; 0,15 A; 130°C	ANSI/UL 94 ANSI/UL 1694 ANSI/UL 723 IEC 62040-1	UL (E59481) UL (E201757) UL (E165111) UL (E17385) UL (E180908) UL (E317427) Tested with the equipment
Connector CN1	CHYAO SHIUNN ELECTRONIC INDUSTRIAL	JS-1110-11	250 Vac; 3A	UL 1977	UL (E113875)
	GREENCONN CORPORATION	GPHB101-1102AA67R1B A	250 Vac; 3A	UL 1977	UL (E221178)

IEC 62040-1					
Clause	Requirement + Test			Result - Remark	Verdict
Transformer TX1	VOLTRONIC POWER TECHNOLOGIES	41-040046- 00G	60 Vdc; 0,4A; 130°C	ANSI/UL 1446 ANSI/UL 94 ANSI/UL 1694 ANSI/UL 723 CAN/UL 510A	UL (E84201) UL (E59481) UL (E17385) UL (E175868)
PCB BM637	GANZHOU BANGDE CIRCUIT TECHNOLOGY	BD-D (BM637B00)	V-0	ANSI/UL 796	UL(E348757)
PCB BM716	GANZHOU BANGDE CIRCUIT TECHNOLOGY	BD-D (BM716A00)	V-0	ANSI/UL 796	UL(E348757)
Fuse FS1, FS2	FERRAZ SHAWMUT (MERSEN)	F330009	10.3X38; 8A; 700 Vac	ANSI/UL 248-1,	UL (E76491)
	COOPER BUSSMANN	FWP-8G10F	10.3X38; 8A; 690 Vac	ANSI/UL 248-1,	UL (E91958)
	DF ELECTRIC	492005	10.3X38; 8A; 690 Vac	ANSI/UL 248-1,	UL (E477155)
Connector CN8	NELTRON INDUSTRIAL CO., LTD	2516S-16G-F1	V-0	UL 1977	UL (E144392)
	FCI	75869-103LF	V-0	UL 1977	UL (E66906)
Connector CN6	CHYAO SHIUNN ELECTRONIC INDUSTRIAL	JS-1120-04	250 Vac; 7A	UL 1977	UL (E113875)
	JST	B4P- VH(LF)(SN)	250 Vac; 10A	UL 1977	UL (E60389)
Connector CN9, CN10, CN11, CN12, CN13	CHYAO SHIUNN ELECTRONIC INDUSTRIAL	JS-1001-02	250 Vac; 3A	UL 1977	UL (E113875)
	JST	B2B-XH-A(LF) (SN)	250 Vac; 3A	UL 1977	UL (E60389)
Capacitor C7, C8	VISHAY	VY2222M35Y 5US63V7	2200pF; 440Vac 125°C	ANSI/UL 60384-14	UL (E183844)
	WALSIN TECHNOLOGY CORPORATION	YV0AC222M0 60DAFD7H	2200pF; 400Vac 85°C	ANSI/UL 60384-14	UL (E146544)
Optocoupler U1, U2	TOSHIBA	TLP191B(U,C, F)	Isolation: 2500 Vrms; 80°C	ANSI/UL 1577	UL (E67349)
Optocoupler U7, U11	FAIRCHILD	FOD817BS	850 Vpeak; 400mA; 175°C	UL 1577	UL (E90700)
	FAIRCHILD	FOD817BSD	850 Vpeak; 400mA; 175°C	UL 1577	UL (E90700)

IEC 62040-1					
Clause	Requirement + Test			Result - Remark	Verdict
	COSMO ELECTRONICS CORPORATION	K10104B	50mA; 115°C; 5000 V Isolation	UL 1577	UL (E169586)
Optocoupler U4, U8	FAIRCHILD	FOD3150S	890 Vpeak; 1 A; 150°C;	ANSI/UL 1577	UL (E90700)
TRANSFORMER TX1, TX2	VOLTRONIC POWER TECHNOLOGIES	41-070402-00G	60 Vdc; 0,2A; 130°C	ANSI/UL 94 ANSI/UL 1694 ANSI/UL 723 ANSI/UL 1446 CAN/UL 510A UL 224 IEC 62040-1	UL (E41429) UL (E176101) UL (E165111) UL (E156256) UL (E87039) Tested with the equipment
CURRENT TRANSFORMER CT1, CT2, CT3, CT4	CLICK	LC12-433	230 V; 0,15 A; 130°C	ANSI/UL 94 ANSI/UL 1694 ANSI/UL 723 ANSI/UL 746E ANSI/UL 746F CAN/UL 510A ANSI/UL 1446 IEC 62040-1	UL (E41938) UL (E123995) UL (E165111) UL (E201757) UL (E85640) Tested with the equipment
INDUCTOR L1, L2	VOLTRONIC POWER TECHNOLOGIES	41-110139-00G	400 V; 19A; 842uH; 155°C	ANSI/UL 1446 ANSI/UL 746E ANSI/UL 94 ANSI/UL 746F ANSI/UL 1694 ANSI/UL 723 IEC 62040-1	UL (E85640) UL (E123995) UL (E218090) UL (E75225) Tested with the equipment
BM639C00PCB BM692	GANZHOU BANGDE CIRCUIT TECHNOLOGY	BD-M (BM692C00)	V-0	ANSI/UL 796 ANSI/UL 796F	UL (E348757)
HEAT SHRINK TUBE HSTQ3, HSTQ4	THOMAS & BETTS	DERAY H	600 V; 105 °C	UL 224	UL (E79546)
	DSG-CANUSA GMBH	DERAY H	600 V; 125 °C	UL 224	UL (E107857)
	CHANGYUAN ELECTRONICS GROUP CO LTD	CB-HFT	600 V; 125 °C	UL 224	UL (E180908)
Fuse FS1	COOPER BUSSMANN	TR/3216FF1-R	1A; 32Vac	ANSI/UL 248-1	UL (E19180)
	LITTELFUSE	0466001.NR	1A; 63Vac	ANSI/UL 248-1	UL (E10480)

IEC 62040-1					
Clause	Requirement + Test			Result - Remark	Verdict
Connector CN11	NELTRON INDUSTRIAL CO., LTD	2216S-10G-01-F1	250 Vac; 3A	UL 1977	UL (E144392)
	FCI	71918-210LF	250 Vac; 3A	UL 1977	UL (E66906)
Connector CN33, CN35, CN36, CN39, CN40	NELTRON INDUSTRIAL CO., LTD	2216S-20G-01-F1	250 Vac; 3A	UL 1977	UL (E144392)
	FCI	71918-220LF	1500V; 3A	UL 1977	UL (E66906)
Connector CN2, CN5	BERG	71918-226LF	1500V; 3A	UL 1977	UL (E66906)
	NELTRON INDUSTRIAL CO., LTD	2216S-26G-01-F1	250 Vac; 3A	UL 1977	UL (E144392)
Connector CN38	NELTRON INDUSTRIAL CO., LTD	2216S-30G-01-F1	250 Vac; 3A	UL 1977	UL (E144392)
	FCI	71918-230LF	3A; 1500V	UL 1977	UL (E66906)
Connector CN6, CN34	NELTRON INDUSTRIAL CO., LTD	2216S-16G-01-F1	250 Vac; 3A	UL 1977	UL (E144392)
	FCI	71918-216LF	1500V; 3A	UL 1977	UL (E66906)
Connector CN8	NELTRON INDUSTRIAL CO., LTD	2516S-26G-F1	250 Vac; 3A	UL 1977	UL (E144392)
	FCI	75869-105LF	500 V; 3A	UL 1977	UL (E66906)
Connector CN9	NELTRON INDUSTRIAL CO., LTD	2516S-14G-F1	250 Vac; 3A	UL 1977	UL (E144392)
	FCI	75869-102LF	500 V; 3A	UL 1977	UL (E66906)
Connector CN27	CHYAO SHIUNN ELECTRONIC INDUSTRIAL	JS-1001-02	250 Vac; 3A	UL 1977	UL (E113875)
	JST	B2B-XH-A(LF) (SN)	250 Vac; 3A	UL 1977	UL (E60389)
Connector CN47	CHYAO SHIUNN ELECTRONIC INDUSTRIAL	JS-1001-07	250 Vac; 3A	UL 1977	UL (E113875)
	JST	B7B-XH-A(LF) (SN)	250 Vac; 3A	UL 1977	UL (E60389)
Connector CN37	JST	B6B-XH-A(LF) (SN)	250 Vac; 3A	UL 1977	UL (E60389)
Connector	MOLEX	95501-2441	1,5A; 125 Vdc	ANSI/UL 1863 UL 1977	UL (E107635)

IEC 62040-1					
Clause	Requirement + Test			Result - Remark	Verdict
CN19, CN20	HONG YU TELECOM PRODUCTS., LTD	HY53A44-0110	125 Vac; 1,5A	ANSI/UL 1863 UL 1977	UL (E304354)
	FCI	87180-044LF	1A; 1kV	ANSI/UL 1863 UL 1977	UL (E82037)
Connector CN22, CN24, CN25, CN41, CN42, CN43, CN44, CN46	CHYAO SHIUNN ELECTRONIC INDUSTRIAL	JS-1109-02	250 Vac; 3A	UL 1977	UL (E113875)
	GREENCONN CORPORATION	GPHA101-0202A001A1BA	250 Vac; 3A	UL 1977	UL (E221178)
Connector CN14, CN15	CHYAO SHIUNN ELECTRONIC INDUSTRIAL	JS-1106-7	250 Vac; 3A	UL 1977	UL (E113875)
Connector CN45	CHYAO SHIUNN ELECTRONIC INDUSTRIAL	JS-1106-5	250 Vac; 3A	UL 1977	UL (E113875)
Connector CN29, CN30	GREENCONN CORPORATION	GPFA202-0302AXXA1SA (A5,B2.3)	500 Vac; 2A	UL 1977	UL (E221178)
Battery BT1	PANASONIC	CR1620	3V 75mAh	UL 1642	UL (MH12210)
	ENERGIZER	CR1620	3V 75mAh	UL 1642	UL (MH12454)
TRANSFORMER TR1	CLICK	BCK1201-140	60 V; 0,24 A; 130°C	ANSI/UL 94 ANSI/UL 1694 ANSI/UL 723 CAN/UL 510A UL 1446 ANSI/UL 2353 ANSI/UL 746A IEC 62040-1	UL (E41429) UL (E165111) UL (E246950) UL (E75225) UL (E83702) UL (E308908) UL (E206440) UL (E218090) Tested with the equipment
PCB BM639	LAB CIRCUITS	M (BM639C00)	V-0	ANSI/UL 796 ANSI/UL 796F	UL (E118193)
	XIN MAN DA CIRCUIT (SHENZHEN) CO LTD	2 (BM639C00)	V-0	ANSI/UL 796 ANSI/UL 796F	UL (E308011)
Fuse FS1, FS2, FS3, FS4	FERRAZ SHAWMUT (MERSEN)	H093295	6.3X32 1A; 690 V	ANSI/UL 248-1	UL (E76491)
	SIBA	70 125 40.1	6.3X32 1A; 700 V	ANSI/UL 248-1	UL (E180276)
Fuse FS5, FS6, FS7, FS8, FS9,	LITTELFUSE	0477002MXP	5X20 2A	ANSI/UL 248-1 ANSI/UL 248-14	UL (E10480)

IEC 62040-1					
Clause	Requirement + Test			Result - Remark	Verdict
FS10	VICTORS INDUSTRIAL CO., LTD	UDE 002	5X20 2A 500V	ANSI/UL 248-1 ANSI/UL 248-14	UL (E357828)
Fuse FS11, FS12, FS13, FS14	COOPER BUSSMANN	TR/3216FF1.5-R	32Vac; 1,5A	ANSI/UL 248-1 ANSI/UL 248-14	UL (E19180)
	LITTELFUSE	046601.5NR	63Vac; 1,5A	ANSI/UL 248-1 ANSI/UL 248-14	UL (E10480)
Fuse holder FH5A, FH6A, FH7A, FH8A, FH9A, FH10A	VICTORS INDUSTRIAL CO., LTD	PTF78	250 V; 6,3A; 5x20	ANSI/UL 248-1	UL (E157417)
	WURTH ELEKTRONIK	696101000002	250 V; 10A; 5x20	ANSI/UL 248-1	UL (E157417)
	WURTH ELEKTRONIK	696108003002	250 V; 20A; 5x20	ANSI/UL 248-1	UL (E157417)
Fuse holder FH1A, FH1B, FH2A, FH2B, FH3A, FH3B, FH4A, FH4B	FERRAZ SHAWMUT (MERSEN)	K222051	Ø6.3	UL 4248-1	UL (E52283)
	COOPER BUSSMANN	1A1907-06-R	Ø6.3	UL 4248-1	UL (E14853)
	LITTELFUSE	10207101009	Ø6.3	UL 4248-1	UL (E14721)
	KEYSTONE	3529	Ø6.3	UL 4248-1	UL (E354010)
Connector CN6	BERG	71918-226LF	3A; 1,5kV	UL 1977	UL (E66906)
	NELTRON INDUSTRIAL CO., LTD	2216S-26G-01-F1	250 Vac; 3A	UL 1977	UL (E144392)
Connector CN7, CN8, CN9	CHYAO SHIUNN ELECTRONIC INDUSTRIAL	JS-1120-02	250 Vac; 7A	UL 1977	UL (E113875)
	JST	B2P-VH(LF)(SN)	250 Vac; 10A	UL 1977	UL (E60389)
Connector CN1, CN2, CN11	CHYAO SHIUNN ELECTRONIC INDUSTRIAL	JS-1120-04	250 Vac; 7A	UL 1977	UL (E113875)
	JST	B4P-VH(LF)(SN)	250 Vac; 10A	UL 1977	UL (E60389)
Connector CN16	CHYAO SHIUNN ELECTRONIC INDUSTRIAL	JS-1120-05	250 Vac; 7A	UL 1977	UL (E113875)
	JST	B5P-VH(LF)(SN)	250 Vac; 10A	UL 1977	UL (E60389)

IEC 62040-1					
Clause	Requirement + Test			Result - Remark	Verdict
Connector CN3, CN4	CHYAO SHIUNN ELECTRONIC INDUSTRIAL	JS-1120-08	250 Vac; 7A	UL 1977	UL (E113875)
	JST	B8P-VH(LF)(SN)	250 Vac; 10A	UL 1977	UL (E60389)
Connector CN3, CN4	CHYAO SHIUNN ELECTRONIC INDUSTRIAL	JS-1001-02	250 Vac; 3A	UL 1977	UL (E113875)
	JST	B2B-XH-A(LF)(SN)	250 Vac; 3A	UL 1977	UL (E60389)
Connector CN17, CN18, CN19, CN20	CHYAO SHIUNN ELECTRONIC INDUSTRIAL	JS-1001-03	250 Vac; 3A	UL 1977	UL (E113875)
	CHANGJIANG CONNECTORS	A2501WV-3	250 Vac; 3A	UL 1977	UL (E326732)
	JST	B3B-XH-A(LF)(SN)	250 Vac; 3A	UL 1977	UL (E60389)
Capacitor C3, C4, C6, C7	VISHAY	VY2222M35Y5US63V7	22000 pF; 440V	ANSI/UL 60384-14	UL (E183844)
	WALSIN TECHNOLOGY CORPORATION	YV0AC222M060DAFD7H	2200pF; 400Vac 85°C	ANSI/UL 60384-14	UL (E146544)
Capacitor C9, C97	TDK	CD16-E2GA472MY	4700 pF; 400 Vac; 125°C	ANSI/UL 60384-14	UL (E37861)
	MURATA	DE1E3KX472MB6BA01	4700 pF; 250 Vac; 125°C	ANSI/UL 60384-14	UL (E37921)
	VISHAY	WKP472MCPEJ0KR	4700 pF; 500 Vac; 125°C	ANSI/UL 60384-14	UL (E183844)
	VISHAY	VY1472M63Y5UG6TVX	4700 pF; 500 Vac; 125°C	ANSI/UL 60384-14	UL (E183844)
	TAISHAN CITY JUHONG ELECTRONICS LTD	MY5V472PMAC400VP9.5D11P	4700 pF; 400 Vac; 125°C	ANSI/UL 60384-14	UL (E253194)
	ZONKAS ELECTRONICS CO LTD	J1472M2GY5VS9LEN	4700 pF; 400 Vac; 125°C	ANSI/UL 60384-14	UL (E258931)
Optocoupler OP4	TOSHIBA	TLP181(GB)	Isolation 3750 Vrms; 50mA	ANSI/UL 1577	UL (E67349)
	TOSHIBA	TLP185(GB)	Isolation 3750 Vrms; 10mA	ANSI/UL 1577	UL (E67349)

IEC 62040-1					
Clause	Requirement + Test			Result - Remark	Verdict
	LITEON	LTV-356T	Isolation 5 kVrms; 50mA	ANSI/UL 1577	UL (E113898)
Optocoupler OP2	FAIRCHILD SEMICONDUCT OR CORP	FOD2741ASDV	Isolation 5 kVrms; 20mA	ANSI/UL 1577	UL (E90700)
Optocoupler OP1, OP3, OP5, OP6	LITEON	LTV-352T	Isolation 5 kVrms; 50mA	ANSI/UL 1577	UL (E113898)
Optocoupler OP7	TOSHIBA	TLP152(TPL,E)	Isolation 3750 Vrms; 15mA	ANSI/UL 1577	UL (E67349)
Transformer TR2	CLICK	IE239A00/BCK120 1-136	60 V; 0,1 A;130°C	ANSI/UL 94 ANSI/UL723 ANSI/UL 1694 CAN/UL 510A UL 1446 ANSI/UL 2353 ANSI/UL 746A IEC 62040-1	UL (E41429) UL (E165111) UL (E246950) UL (E75225) UL (E83702) UL (E308908) UL (E206440) Tested with the equipment
Transformer TR1	CLICK	IE241B00/BCK320 1-107	1000 V; 0,62 A; 130°C	ANSI/UL 94 ANSI/UL723 ANSI/UL 1694 CAN/UL 510A UL 1446 ANSI/UL 2353 ANSI/UL 746A UL224 IEC 62040-1	UL (E41938) UL (E201757) UL (E85640) UL (E165111) UL (E246950) UL (E83702) UL (E75225) UL (E156256) UL (E308908) UL (E206440) Tested with the equipment
Transformer TR3	CLICK	IE1242A00/BCK16 01-2138	60 V; 0,62 A; 130°C	ANSI/UL 94 ANSI/UL723 ANSI/UL 1694 CAN/UL 510A UL 1446 IEC 62040-1	UL (E201757) UL (E172395) UL (E234896) UL (E41429) UL (E83702) UL (E75225) UL (E218090) UL (E165111) UL (E246950) Tested with the equipment

IEC 62040-1					
Clause	Requirement + Test			Result - Remark	Verdict
PCB BM693	GANZHOU BANGDE CIRCUIT TECHNOLOGY CO	BM693D00 (BD-M)	V-0	ANSI/UL 796 ANSI/UL 796F	UL (E348757)
Relay RL1, RL2, RL3, RL4	PANASONIC	APF30212	Coil 12 Vdc; 6A; 250 Vac	UL 508 UL 60947-1 UL 60947-4-1	E120782
	FINDER	34.51.7.012.0010	Coil 12 Vdc; 6A; 250 Vac	UL 508 UL 60947-1 UL 60947-4-1	E106390
	SCHRACK	V23092-A1012-A301	Coil 12 Vdc; 6A; 250 Vac	UL 61810-1	E214025
	XIAMEN HONGFA ELECTROACOUSTIC	HF41F/012-ZT	Coil 12 Vdc; 6A; 250 Vac	UL 508 UL 60947-1 UL 60947-4-1	UL (E133481)
	XIAMEN HONGFA ELECTROACOUSTIC	HF41F/012-Z	Coil 12 Vdc; 6A; 250 Vac	UL 508 UL 60947-1 UL 60947-4-1	UL (E133481)
	XIAMEN HONGFA ELECTROACOUSTIC	HF41F/012-ZST	Coil 12 Vdc; 6A; 250 Vac	UL 508 UL 60947-1 UL 60947-4-1	UL (E133481)
	XIAMEN HONGFA ELECTROACOUSTIC	HF41F/012-ZS	Coil 12 Vdc; 6A; 250 Vac	UL 508 UL 60947-1 UL 60947-4-1	UL (E133481)
Connector CN3	NELTRON INDUSTRIAL CO., LTD	2516S-10G-F1	250 Vac; 3A	UL 1977	UL (E144392)
	FCI	75869-101LF	250 Vac; 3A	UL 1977	UL (E66906)
Connector CN1	NELTRON INDUSTRIAL CO., LTD	2516R-26G-F1	250 Vac; 3A	UL 1977	UL (E144392)
	WURTH ELEKTRONIK	61202621721	250 Vac; 3A	UL 1977	UL (E323964)
Connector CN29, CN30	NELTRON INDUSTRIAL CO., LTD	2516R-10G-F1	250 Vac; 3A	UL 1977	UL (E144392)
	WURTH ELEKTRONIK	61201021721	250 Vac; 3A	UL 1977	UL (E323964)

IEC 62040-1					
Clause	Requirement + Test			Result - Remark	Verdict
Connector CN2	NELTRON INDUSTRIAL CO., LTD	2516R-14G-F1	250 Vac; 3A	UL 1977	UL (E144392)
	WURTH ELEKTRONIK	61201421721	250 Vac; 3A	UL 1977	UL (E323964)
Connector CN7	TYCO ELECTRONICS	1734354-1	6A; 105°C; V-0	UL 1977	UL (E28476)
Connector CN16	CHYAO SHIUNN ELECTRONIC INDUSTRIAL	JS-1001-02	250 Vac; 3A	UL 1977	UL (E113875)
	JST	B2B-XH-A(LF) (SN)	250 Vac; 3A	UL 1977	UL (E60389)
Connector CN5	WEIDMULLER	615016240521	120 Vac; 1,5A	UL 1977 ANSI/UL 1863	UL (E324776)
	PULSE	E5908-4V0S54-L	125 Vac; 1,5A	UL 1977 ANSI/UL 1863	UL (E163191)
Connector CN14, CN15, CN18, CN19, CN20	CHYAO SHIUNN ELECTRONIC INDUSTRIAL	JS-1109-02	250 Vac; 3A	UL 1977	UL (E113875)
	GREENCONN CORPORATION	GPHA101-0202A001A1BA	250 Vac; 3A	UL 1977	UL (E221178)
Connector CN31, CN32	CHYAO SHIUNN ELECTRONIC INDUSTRIAL	JS-1109-03	250 Vac; 3A	UL 1977	UL (E113875)
	GREENCONN CORPORATION	GPHA101-0302A001A1BA	250 Vac; 3A	UL 1977	UL (E221178)
Connector CN26, CN27	CHANGJIANG CONNECTORS	A2005WR-2X7P	250 V; 2A	UL 1977	UL (E326732)
Connector CN22, CN23	CHANGJIANG CONNECTORS	A2005WR-2X13P	250 V; 2A	UL 1977	UL (E326732)
Connector CN21	CHANGJIANG CONNECTORS	A2005HWV-2X13P	250 V; 2A	UL 1977	UL (E326732)
Connector CN25	CHANGJIANG CONNECTORS	A2005HWV-2X7P	250 V; 2A	UL 1977	UL (E326732)
Connector CN6	NELTRON INDUSTRIAL CO., LTD	5075BR-04-WH-15	30 V; 1A	UL 1977	UL (E144392)
	FCI	61729-0010BLF	30 V; 1A	UL 1977	UL (E66906)

IEC 62040-1					
Clause	Requirement + Test			Result - Remark	Verdict
Connector CN8	PHOENIX CONTACT	MC 1,5/ 2-G-3,81	250 V; 8A	ANSI/UL 486A-486B	UL (E60425)
	AMPHENOL ANYTEK	OQ0232810000 G	300 V; 10 A	ANSI/UL 1059 ANSI/UL 60947-7-1 ANSI/UL 60947-7-2 ANSI/UL 60947-7-3 ANSI/UL 60947-7-4 ANSI/UL 60947-1	UL (E202113)
Connector CN8B, CN9AB, CN9BB, CN10AB, CN10BB, CN11AB, CN11BB	PHOENIX CONTACT	MC 1,5/ 2-ST-3,81	320 V; 8A	ANSI/UL 486A-486B	UL (E60425)
	AMPHENOL ANYTEK	TJ0231530000G	300 V; 10 A	ANSI/UL 1059 ANSI/UL 60947-7-1 ANSI/UL 60947-7-2 ANSI/UL 60947-7-3 ANSI/UL 60947-7-4 ANSI/UL 60947-1	UL (E202113)
Connector CN9, CN10, CN11	PHOENIX CONTACT	MCD 1,5/ 2-G1-3,81	320 V; 8A	ANSI/UL 486A-486B	UL (E60425)
	AMPHENOL ANYTEK	KE043151A000 G	300 V; 5,5 A	ANSI/UL 1059 ANSI/UL 60947-7-1 ANSI/UL 60947-7-2 ANSI/UL 60947-7-3 ANSI/UL 60947-7-4 ANSI/UL 60947-1	UL (E202113)
Connector CN12, CN13	PHOENIX CONTACT	MCD 1,5/ 3-G1-3,81	320 V; 8A	ANSI/UL 486A-486B	UL (E60425)
	AMPHENOL ANYTEK	KE063151A000 G	300 V; 5,5 A	ANSI/UL 1059 ANSI/UL 60947-7-1 ANSI/UL 60947-7-2 ANSI/UL 60947-7-3 ANSI/UL 60947-7-4 ANSI/UL 60947-1	UL (E202113)
Connector CN12AB, CN12BB, CN13AB, CN13BB	PHOENIX CONTACT	MC 1,5/ 3-ST-3,81	320 V; 8A	ANSI/UL 486A-486B	UL (E60425)
	AMPHENOL ANYTEK	TJ0331530000G	300 V; 10 A	ANSI/UL 1059 ANSI/UL 60947-7-1 ANSI/UL 60947-7-2 ANSI/UL 60947-7-3 ANSI/UL 60947-7-4 ANSI/UL 60947-1	UL (E202113)
Connector C29	EVOX RIFA	PME271YA4220 MR19T0	2200pF; 300 Vac; 115 °C	ANSI/UL 60384-14	UL (E73869)
	ARCOTRONICS (KEMET)	R413F12200000 M	2200pF; 300 Vac; 110 °C	ANSI/UL 60384-14	UL (E97797)

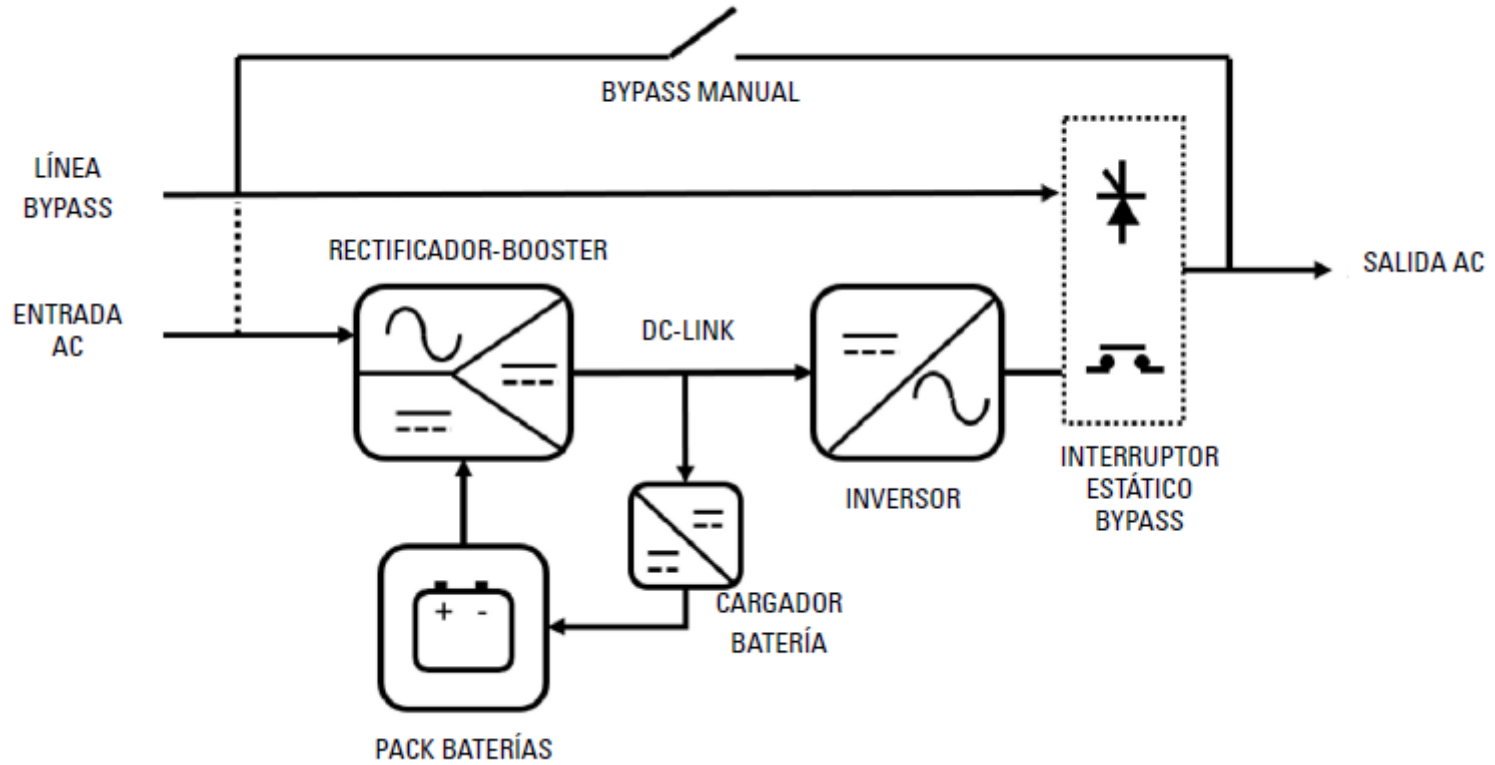

IEC 62040-1					
Clause	Requirement + Test			Result - Remark	Verdict
	EPCOS	B32021A3222M	2200pF; 300 Vac; 110 °C	ANSI/UL 60384-14	UL (E97863)
Optocoupler OP4, OP5, OP7, OP8, OP15, OP16, OP17	AVAGO TECHNOLOGIE S	ACPL-W454	Isolation 3720 Vrms; 230 mA	UL 1577	UL (E55361)
Optocoupler OP1, OP2, OP6, OP9, OP10, OP11, OP12, OP13, OP14, OP18	LITEON	LTV-817S	Isolation 5000 Vrms; 5 mA	UL 1577	UL (E113898)
Optocoupler OP19	BROADCOM LIMITED (AVAGO)	HCNR201-300E	Isolation 5000 Vrms; 25 mA	UL 1577	UL (E55361)
Transformer TR1	CLICK	IE235A00/BCK1 601-2077	60 V; 0,7 A, 130°C	ANSI/UL 1446 ANSI/UL 94 ANSI/UL 1694 ANSI/UL 723 UL 224 CAN/UL 510A ANSI/UL 2353 ANSI/UL 746A IEC 62040-1	UL (E201757) UL (E172395) UL (E234896) UL (E41429) UL (E83702) UL (E75225) UL (E156256) UL (E165111) UL (E246950) UL (E308908) UL (E206440) UL (E166483) UL (E218090) Tested with the equipment
PCB BM694	GANZHOU BANGDE CIRCUIT TECHNOLOGY CO	BM694 (BD-M)	V-0	ANSI/UL 796, ANSI/UL 796F,	UL (E348757)
Connector CN1, CN2, CN3, CN6, CN7, CN8, CN11, CN12, CN13, CN17, CN18, CN20, CN21, CN23, CN24	NELTRON INDUSTRIAL CO., LTD	2216S-20G-01- F1	250 Vac; 3A	UL 1977	UL (E144392)
	FCI	71918-220LF	1500V; 3A	UL 1977	UL (E66906)
Connector CN5,	BERG	71918-226LF	1500V; 3A	UL 1977	UL (E66906)

IEC 62040-1					
Clause	Requirement + Test			Result - Remark	Verdict
CN10	NELTRON INDUSTRIAL CO., LTD	2216S-26G-01-F1	250 Vac; 3A	UL 1977	UL (E144392)
Connector CN5, CN10, CN4, CN9, CN14, CN16, CN19, CN22	NELTRON INDUSTRIAL CO., LTD	2216S-16G-01-F1	250 Vac; 3A	UL 1977	UL (E144392)
	FCI	71918-216LF	1500V; 3A	UL 1977	UL (E66906)
Connector CN15	NELTRON INDUSTRIAL CO., LTD	2516S-26G-F1	250 Vac; 3A	UL 1977	UL (E144392)
	FCI	75869-105LF	500 V; 3A	UL 1977	UL (E66906)
PCB BM720	GANZHOU BANGDE CIRCUIT TECHNOLOGY CO	BM720B00 (BD-M)	V-0	ANSI/UL 796, ANSI/UL 796F,	UL (E348757)
Fuse FS1, FS2, FS3	EATON	63FE	690 Vac; 63 A	UL 248-1	UL (E91958)
PCB BM711	GANZHOU BANGDE CIRCUIT TECHNOLOGY CO	BM711B00 (BD-M)	V-0	ANSI/UL 796, ANSI/UL 796F,	UL (E348757)
Fan	AVC	DAKA1238B2H	12Vdc; 1,3A	UL 507	UL (E158191)
Internal wires	ASCABLE-RECAEL	RZ1-K	0,6 / 1 kV; 90°C; V-0	ANSI/UL 746E ANSI/UL 746F ANSI/UL 94	UL (E33073)
Battery	CSB	HR 1234W	12 V; 34 W; HB	ANSI/UL 1989	UL (MH14533)
Button S1 (optional)	APEM	8642-A-U906	3A; 250 V	UL 1054	UL (E83438)
<p>Supplementary information:</p> <p>¹⁾ Provided evidence ensures the agreed level of compliance. See OD-CB2039.</p> <p><i>NOTE: License available upon request.</i></p>					

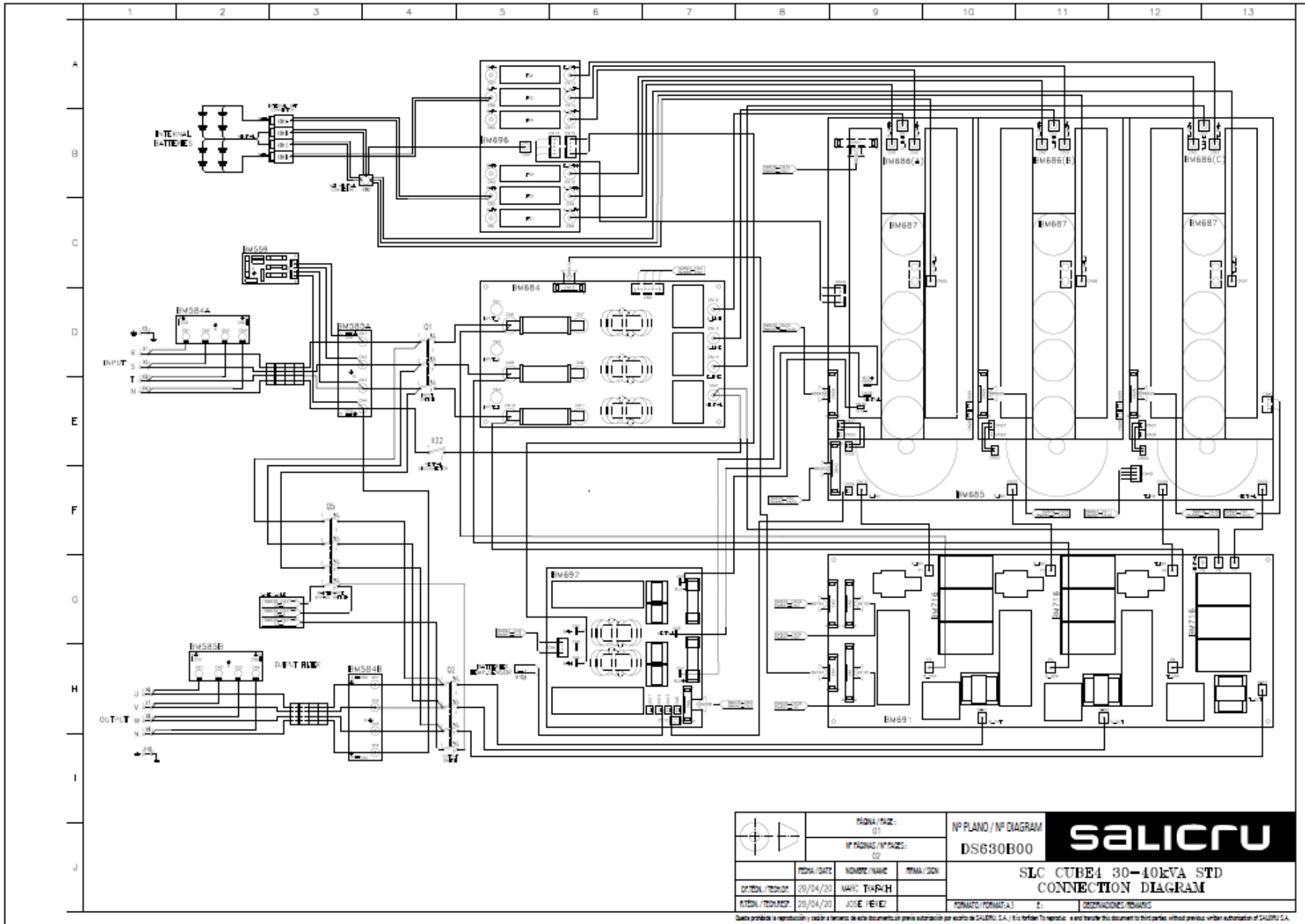

Attachment 1: Electrical diagram



		FOLIO / FOLIO: 01		Nº PLANO / Nº DIAGRAMA DS630B00		
		Nº FOLIOS / Nº FOLIOS: 00		DS630B00		
DT. TECN. / TECN. DT. 29/04/20	NOMBRE / NOMBRE: MARC. / MARCA TIVARH	DT. TECN. / TECN. DT. 29/04/20	NOMBRE / NOMBRE: MARC. / MARCA JOSE / FIELE	DT. TECN. / TECN. DT. 29/04/20	NOMBRE / NOMBRE: MARC. / MARCA JOSE / FIELE	DT. TECN. / TECN. DT. 29/04/20
FOLIO / FOLIO: 01				Nº PLANO / Nº DIAGRAMA: DS630B00		DT. TECN. / TECN. DT.: 29/04/20

SLC CUBE4 30-40kVA STD
 CONNECTION DIAGRAM

FOLIO / FOLIO: 01

Nº PLANO / Nº DIAGRAMA: DS630B00

DT. TECN. / TECN. DT.: 29/04/20

NOMBRE / NOMBRE: MARC. / MARCA: JOSE / FIELE

DT. TECN. / TECN. DT.: 29/04/20

FOLIO / FOLIO: 01

DT. TECN. / TECN. DT.: 29/04/20

Queda prohibida la reproducción o cualquier forma de explotación de este documento sin la autorización expresa de SALICRU S.A. / It is forbidden to reproduce or exploit this document without the express authorization of SALICRU S.A.

Attachment 1: Electrical diagram

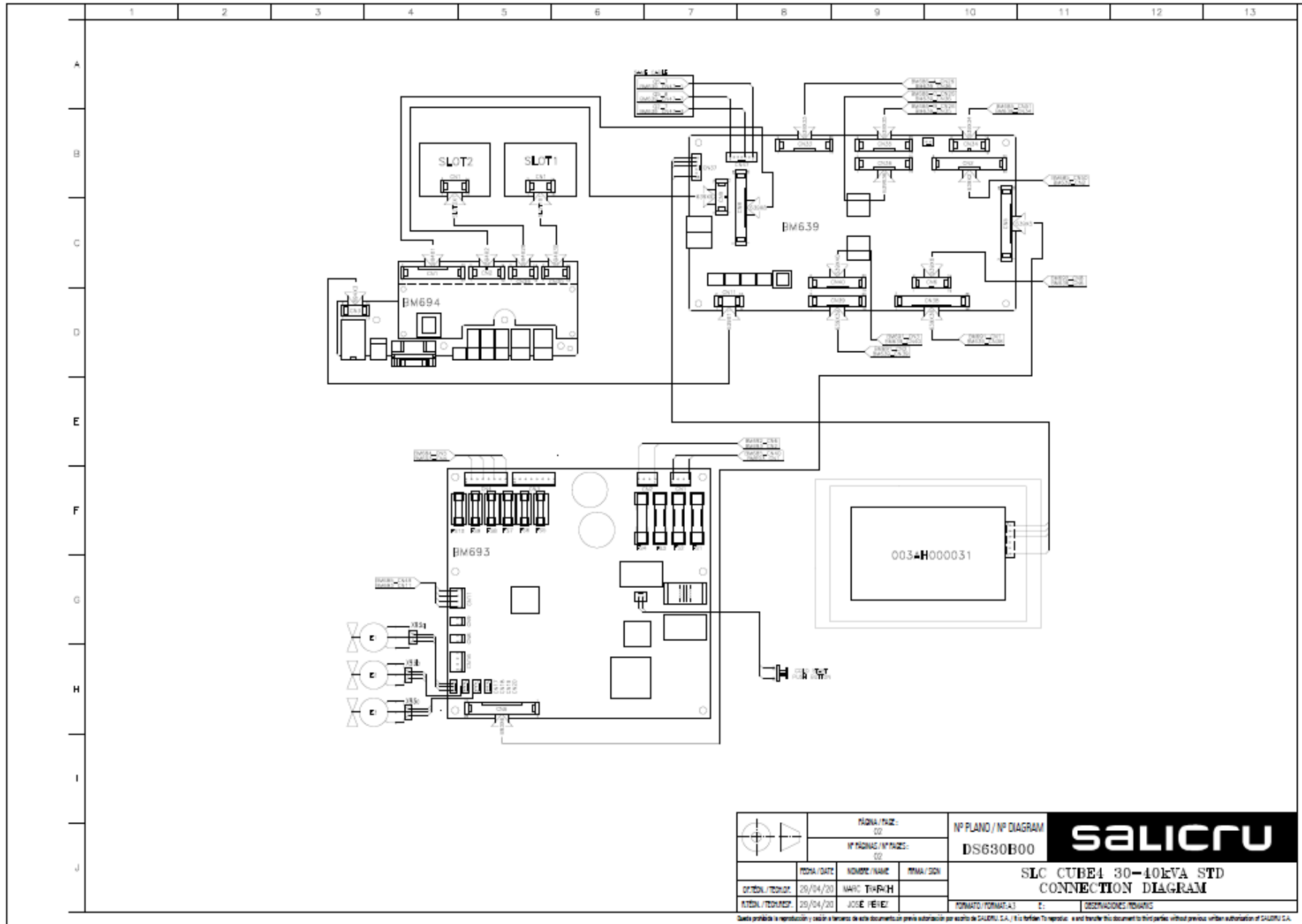

	PÁGINA / PAJE:		00		salicru
	Nº PÁGINAS / Nº PÁJES:		00		
Nº PLANO / Nº DIAGRAMA			DS630B00		
OP.TECN./TECNIC.	29/04/20	MARK THORP	SLC CUBE4 30-40kVA STD CONNECTION DIAGRAM		
AL.TECN./TECNIC.	29/04/20	JOSE FIEBEL	FORMATO / FORMATEO: E: OBSERVACIONES / OBSERVATIONS		

Queda prohibida la reproducción y uso sin el consentimiento de este documento sin previa autorización por escrito de SALICRU S.A. / It is forbidden to reproduce or use this document without previous written authorization of SALICRU S.A.

Attachment 1: Electrical diagram

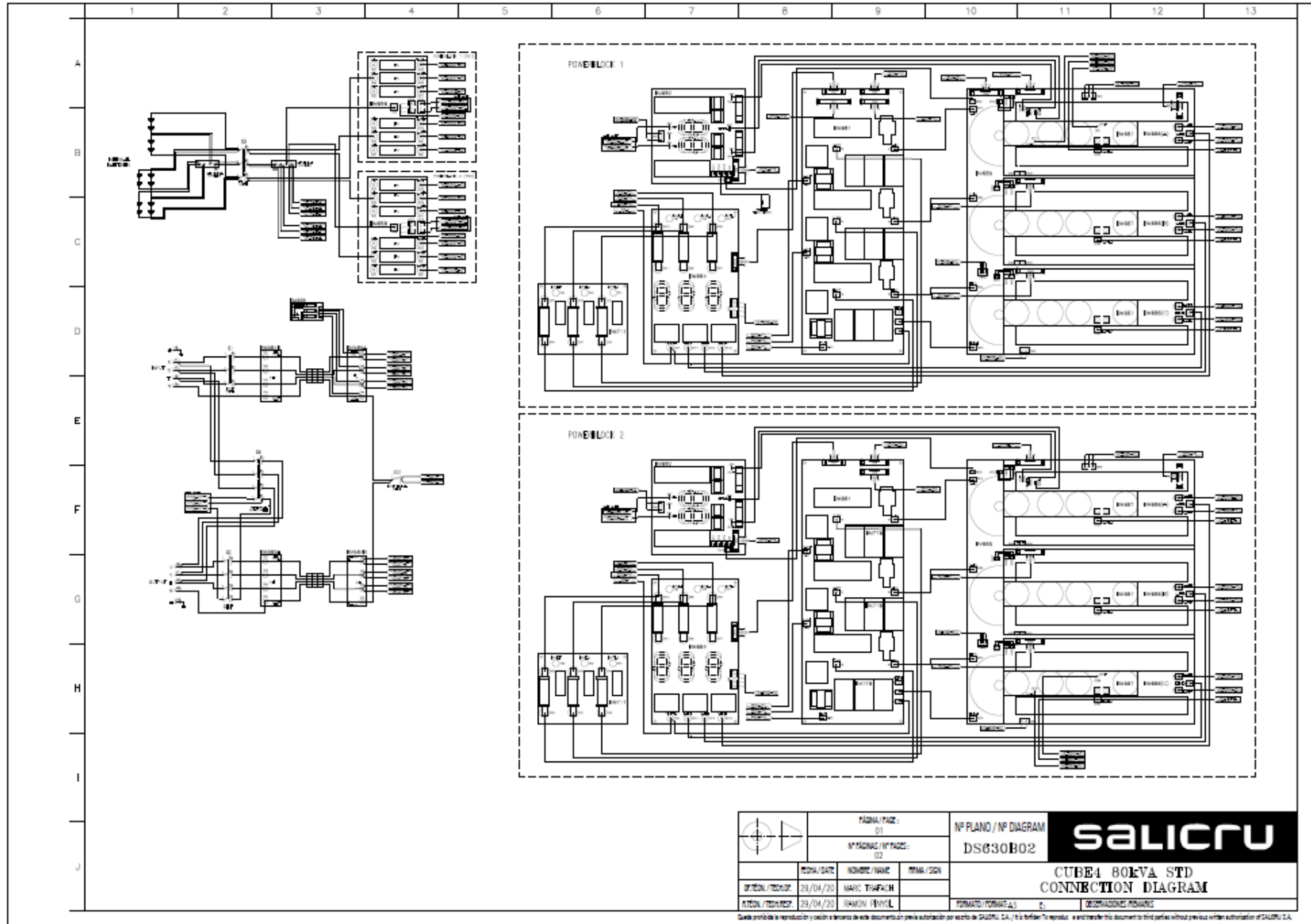

		FOLIO / PAGE:		NP PLANO / NP DIAGRAM		
		01		DS630B02		
		MAYOR / NUMBER:		CUBETA 80KVA STD		CONEXION DIAGRAM
		02				
DISEÑO / DESIGN: 29/04/20	FECHA / DATE: 29/04/20	NOMBRE / NAME: MARC: TIFAIR	TIPO / CODE: 			
AUTORIZADO / AUTHORIZED: 29/04/20		INGENIERO / ENGINEER: MARC: TIFAIR		FORMATO / FORMAT: A3		OBSERVACIONES / REMARKS:

Queda prohibida la reproducción o cualquier uso no autorizado de este documento sin el consentimiento escrito de SALICRU, S.A. / It is forbidden to reproduce or transfer this document to third parties without previous written authorization of SALICRU, S.A.

Attachment 1: Electrical diagram

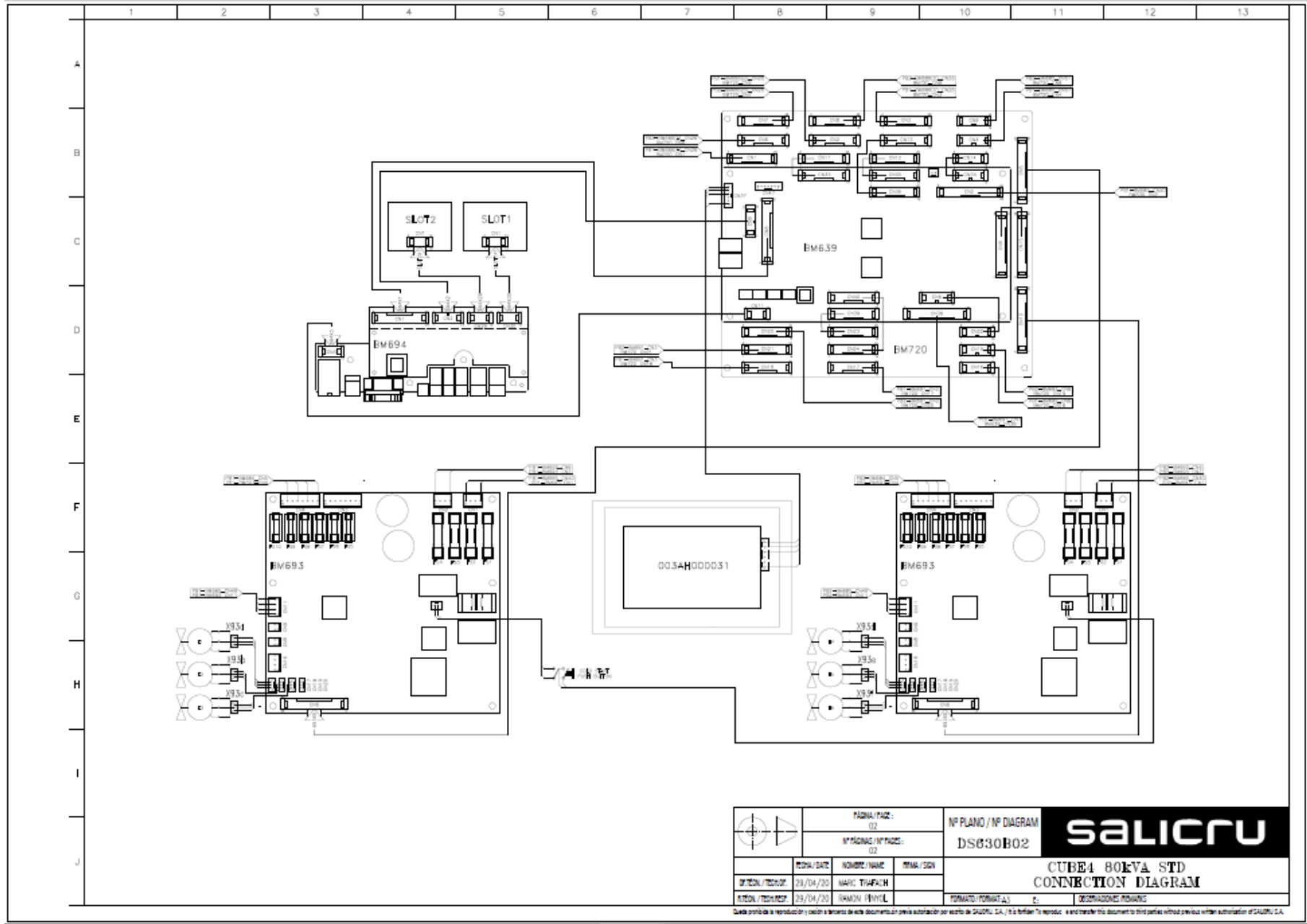

	PÁGINA / PAGE: 02		salicru CUBE4 80kVA STD CONNECTION DIAGRAM
	Nº PÁGINAS / Nº PAGES: 02		
EDICIÓN / VERSION: 29/04/20 AUTORIZADO / AUTHORIZED: 29/04/20	NOMBRE / NAME: MARCO THAFACH GRUPO / GROUP: RAMON FENYUL	Nº PLANO / Nº DIAGRAM: DS630B02 FORMATO / FORMAT: 2:	DESEÑADOR / DESIGNER:

Cada vez que se reproduce o copia o imprime este documento previa autorización por escrito de SALICRU, S.A. / It is forbidden to reproduce, copy and transfer this document to third parties without previous written authorization of SALICRU, S.A.

SLC-40-CUBE4



Attachment 2: Pictures

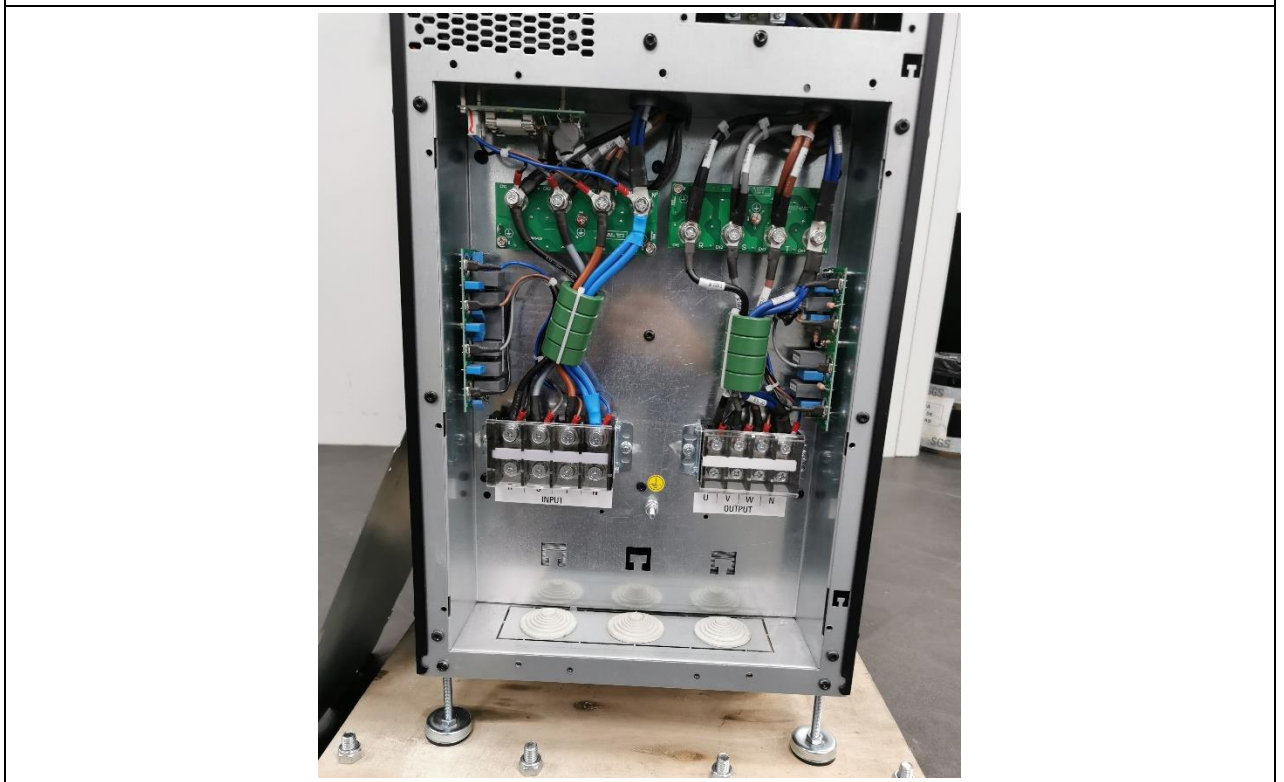

Attachment 2: Pictures



Attachment 2: Pictures

SLC-80-CUBE4





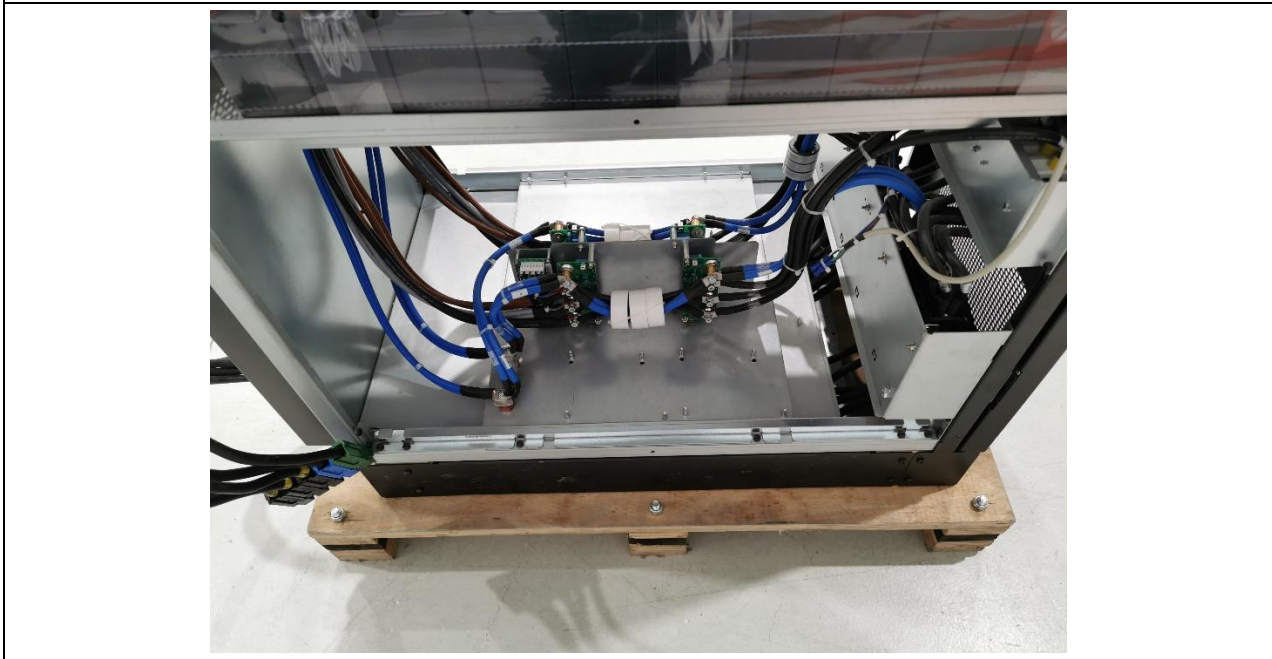

Attachment 2: Pictures



Attachment 3: Test equipment list

No. (*)	TEST EQUIPMENT	Manufacturer / Model	SGS INT. CODE N°	CALIBRATION DATE	
				LAST	DUE
4	JOINTED TEST FINGER	ED&D / TFP-01	DIE.000192	11/09/2020	11/09/2025
13	Thead 2,5 mm CALIBRE C	E.D.&D. / TRP-01	DIE.000202	04/03/2019	04/03/2022
15	RIGID TEST FINGER	CTC / 221	DIE.000221	16/10/2017	16/10/2022
21	TEMPERATURE RECORDER	YOKOGAWA/MV2030	DIE.010110	25/10/2021	25/10/2022
28	GONIOMETER	ARISTO / SOLA	DIE.100063	20/09/2021	20/09/2024
31	CALLIPER	MITUTOYO / CD-8°CSX	DIE.120110	14/01/2021	14/04/2022
35	CHRONOMETER	STOP WATCH / C-510	DIE.210061	22/12/2020	22/03/2022
36	DIGITAL DYNAMOMETER	PCE / DFG500	DIE.310150	10/03/2021	10/03/2022
43	SONOMETER	AMPROBE/ SM-10	DIE.410000	19/10/2020	19/10/2022
53	AMPERIMETRIC CLAMP	HIOKI / 9660	DIE.510010-1	02/06/2021	02/06/2022
62	POWER ANALIZER	YOKOGAWA / WT3000	DIE.510014	12/08/2021	12/08/2022
72	AMPERIMETRIC CLAMP FLEX 3000A	PEM ROGOWSKI / CWT 15B	DIE.510040	18/05/2021	18/05/2022
73	AMPERIMETRIC CLAMP FLEX 3000A	PEM ROGOWSKI / CWT 15B	DIE.510041	18/05/2021	18/05/2022
74	AMPERIMETRIC CLAMP FLEX 3000A	PEM ROGOWSKI / CWT 15B	DIE.510042	17/06/2021	17/06/2022
75	AMPERIMETRIC CLAMP FLEX 3000A	PEM ROGOWSKI / CWT 15B	DIE.510043	18/05/2021	18/05/2022
80	MULTIMETER AMP. CLAMP 2000A	HIOKI / 3285	DIE.510051	13/05/2021	13/05/2022
92	MULTIMETER	FLUKE/289	DIE.560040	20/12/2021	20/12/2022
97	HIGH TENSION TESTER	UH/28 M	DIE.570034	20/07/2021	20/07/2022
101	SAFETY TESTER	CHAUVIN ARNOUX / C.A 6165	DIE.580060	11/03/2021	11/03/2022
102	IMPULSE GENERATOR	EMC PARTNER / MIG-2403	DIE.580150	05/01/2022	05/01/2023
108	VOLTAGE PROBE 7KV /2,5Vrms	SAPPHIRE / SI-9010	DIE.610300-05	08/06/2021	08/06/2022
112	VOLTAGE PROBE 7KV /2,5Vrms	SAPPHIRE / SI-9010	DIE.610300-09	28/12/2020	28/12/2021
113	VOLTAGE PROBE 7KV /2,5Vrms	SAPPHIRE / SI-9010	DIE.610300-10	08/06/2021	08/06/2022
114	VOLTAGE PROBE 7KV /2,5Vrms	SAPPHIRE / SI-9010	DIE.610300-11	17/02/2022	17/02/2023
129	METEOROLOGIC Station	PCE / THB38	DIE.840040	14/12/2020	14/03/2022
133	T [°] & R.H. controller	ELIWELL / IC912LX	DIE.850250	21/06/2021	21/09/2022
135	DIGITAL THERMOHYGROMETER	TESTO / 175H2	DIE.850285	15/12/2021	15/03/2023
139	CLIMATIC CHAMBER	WV / C1000	DIE.870250	19/02/2021	19/06/2022
165	AMPERIMETRIC CLAMP	HIOKI / 9660	DIE.510012-5	17/08/2021	17/08/2022
166	AMPERIMETRIC CLAMP	HIOKI / 9660	DIE.510010-6	17/08/2021	17/08/2022
167	AMPERIMETRIC CLAMP	HIOKI / 9660	DIE.510010-5	17/08/2021	17/08/2022

Supplementary information: Test equipment used on valid calibration period.