

AUGUSTA 5 (AUG-10012-SB)



Product description

200x80 mm - 1000 mm - With integrated security core (Anti-traffic)



Luminaire Structure

- Die-cast aluminium housing and frame
- Extruded aluminium column
- Pre-treated before powder coating ensuring high corrosion resistance
- Single cable entry
- One IP68 connector supplied with 0.2 m of 3x1.0 sqmm outdoor cable
- Stainless steel fasteners in grade 304 with zinc flake coating (ZFC)
- Durable silicone rubber gasket
- Toughened glass
- Integral control gear

Optic



G

Product colour



Special finishes upon request



AUGUSTA 5 (AUG-10012-SB)

Technical information

| | |
|----------------------|-----------------------|
| Light source | 40 LED |
| Power | 14 W |
| Lumen | 744 - 796 lm |
| Efficacy | 53 - 57 lm/W |
| Driver option | Integral control gear |
| Driver | Constant current (CC) |
| Input voltage | 220-240 V 50/60 Hz |
| Optic | G |
| Optic value | 75°x105° |

| | |
|------------------------------|--|
| CCT / CRI | 3000K CRI80, 4000K CRI80 |
| Bug | B1-U0-G0 |
| ULR | <1% |
| ULOR | <1% |
| CIE flux code n°3 | 97 |
| Dimming type | On/Off, 1-10V, DALI |
| Product colours | Black, Dark Grey, White, Matt Silver, Bronze, Concrete - Urban, Softscape - Urban, Stone - Urban, Corten - Urban, Oak - Woodland, Walnut - Woodland, Pine - Woodland |
| Weight | 27.9 kg |
| Operating temperature | -20 °C to 40 °C |

| | |
|---------------------------------------|---|
| Cable | One IP68 connector supplied with 0.2 m of 3x1.0 sqmm outdoor cable |
| Through wiring | Single cable entry |
| Lens / Reflector / Optic | Toughened glass |
| MacAdam Ellipse | 3 SDCM |
| Lifetime L90B10 (hours) | > 23,000 |
| Lifetime L80B10 (hours) | > 45,000 |
| Lifetime L80B50 (hours) | > 49,000 |
| Variants (On/Off, 1-10V, DALI) | Compatible with EN/ IEC 60598-2-22: Suitable for emergency installations as central supply, non-maintained (Z0) |

AUG-10012-SB

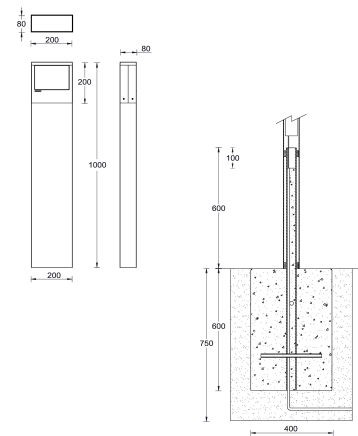

AUGUSTA 5 (AUG-10012-SB)

Accessory



DALI Control System
Control-DALI
