



## **ELECTRIC VEHICLE CHARGER**

**VE 741 S00 / VE 741 M05 / VE 741 M10**

**VE 741 SP0 / VE 741 MP5 / VE 741 MPI**

**VE 742 S00 / VE 742 M05 / VE 742 M10**

**VE 221 S00 / VE 221 M05 / VE 221 M10**

**VE 222 S00 / VE 222 M05 / VE 222 M10**



**ETS USER MANUAL**

---

# INDEX

INTRODUCTION.....	3
Description.....	3
Technical data.....	5
Dimensions.....	5
Connection diagram.....	6
ETS CONFIGURATION.....	7
Configuration parameters.....	7
General.....	7
Status Sending.....	9
Advanced.....	12
Connector.....	14
Dynamic Load Balancing.....	16
Communication Objects.....	25

---

## INTRODUCTION

### Description

The Electric Vehicle Charger incorporates a KNX interface that allows communication with other KNX bus devices through communication objects configurable via ETS® software, enabling its integration into a KNX installation.

- Its main functions are:
  - Charging process control:
    - Automatic start of charging after vehicle connection
    - Automatic disconnection at the end of the session
    - Maximum session time limitation
    - Charger status monitoring
    - Current and power limitations
  - Energy management and power control:
    - Dynamic load balancing
    - Simultaneous balancing of multiple chargers
    - Scheduling charging sessions at time intervals
  - Monitoring and supervision:
    - Charger status
    - Instantaneous charging power
    - Instantaneous charging current
    - Operational and diagnostic information
    - Energy and session time
  - Reliable hardware:
    - Steel enclosure
    - IP54 protection rating
    - IK10 impact resistance
    - Screwless clamp-type terminals
    - Resettable protections
  - Compatibility with a wide range of systems:
    - Communication with OCPP systems
    - RFID access capability
    - KNX compatibility
    - Configurable via Ethernet
    - Bluetooth connection via DINUY – eMobility app
    - Configurable via Wi-Fi through the Cloud platform
- The Charger allows integrating its functions within a KNX system. This makes it possible to control vehicle charging from other KNX devices and monitor its status.
- In addition to other functions, this device sends control commands (start/stop charging, power limitation, dynamic load balancing, etc.) via KNX communication objects configurable in ETS®. Conversely, it sends information about charger status, consumption, and power via KNX telegrams.
- It has 1 or 2 connectors, depending on the model, allowing the management of charging for one or two vehicles simultaneously.
- Depending on the model, it features resettable self-protection in case of overload or session interruption: if a persistent fault is detected, the charger interrupts power to the vehicle for a set period and then safely retries charging.
- Dynamic load balancing between multiple connectors or chargers connected to the same installation.

- 
- Commissioning and maintenance (manual charge control, session supervision, visualization of energy consumed or errors) via ETS® software.
  - Requires electrical supply according to its model: 230 VAC 50/60 Hz for single-phase, or 400 VAC 3-phase 50/60 Hz for three-phase.
  - ETS® software is required for KNX configuration and commissioning.
  - Wall-mounted installation in the garage or parking area.
  - Other features:
    - 2.8" TFT color display with latest LED technology
    - Each charger is supplied with 4 RFID cards
    - Up to 5-year warranty

## Technical data

Supply voltage	Single-phase models: 230 Vac $\pm$ 10 % 50/60 Hz Three-phase models: 400 Vac $\pm$ 10 % 50/60 Hz	
Socket	Socket, 1 or 2 Type 2 connectors 5 or 10 m long depending on the model	
KNX	KNX Supply voltage	21..32Vdc
	KNX Consumption	< 5mA
	Programming via	ETS5 and later versions
	KNX Medium	PTI
	Commissioning	System Mode
Charge mode	3	
Configurable charging current	6 to 32 A	
Cable section	Up to 10 mm <sup>2</sup>	
Connection	screwless spring-clamp terminals	
Communication protocols	Bluetooth, Wi-Fi, Ethernet, KNX, RFID and OCPP	
Installation	Surface-mounted, wall-mounted for indoor or outdoor use	
Material	Steel	
Impact resistance	IK10	
Protection degree	IP54	
Dimensions	322 x 249 x 180	
Weight	From 5.2 kg without cable to 13 kg with two 10 m cables	
Working temperature	-25° C to 45° C	
Storage temperature	-25° C to 75° C	
Operating humidity	5% to 95%	

## Dimensions

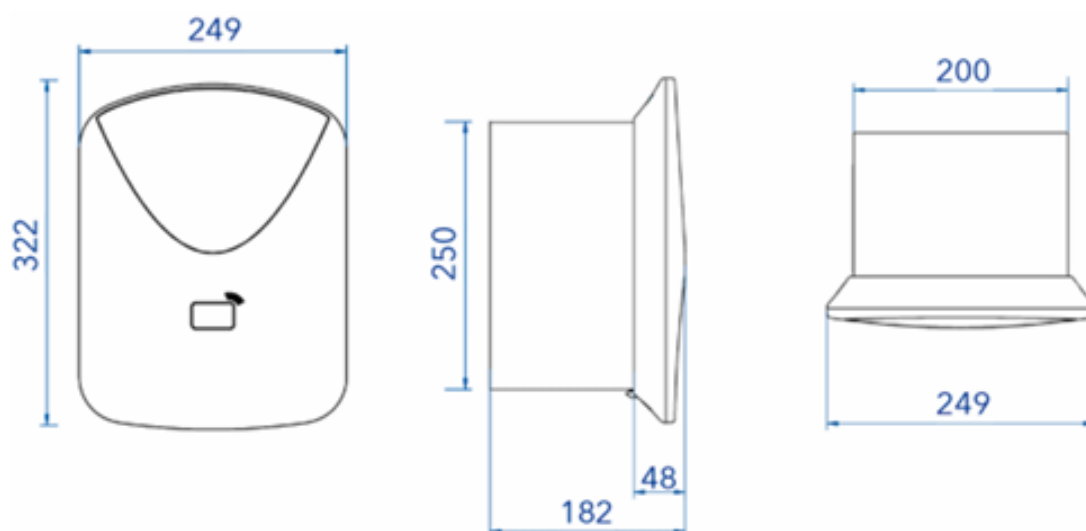

## Connection diagram

- Single-phase 7,4 kW charger with 1 or 2 connectors:

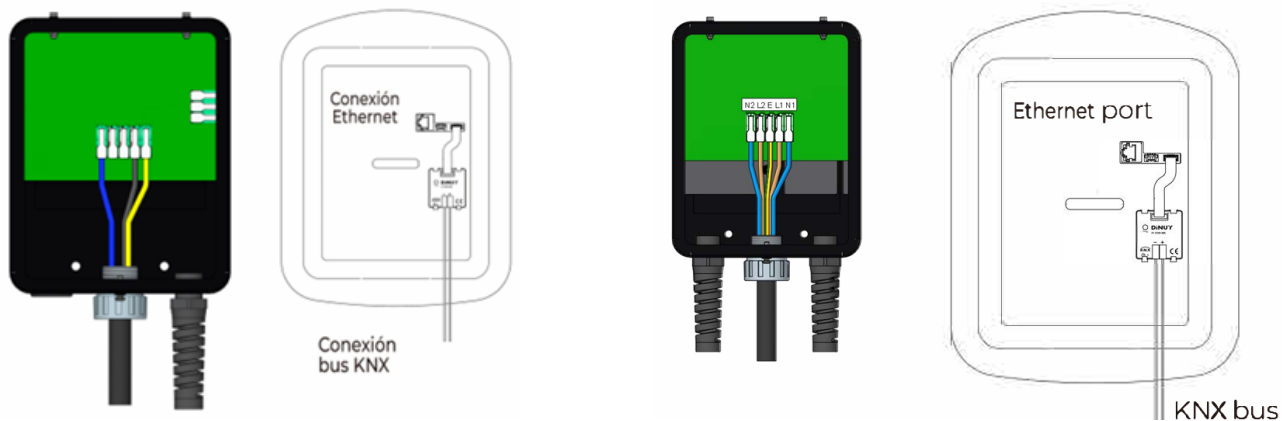

- Single-phase 7,4 kW charger with 1 connector and protections:

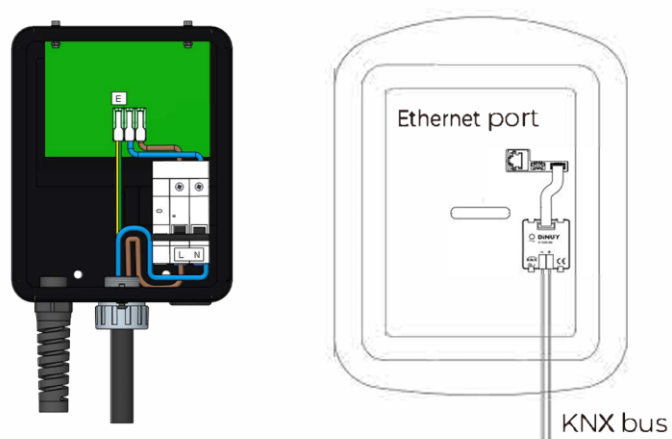

- Three-phase 22 kW charger with 1 or 2 connectors:

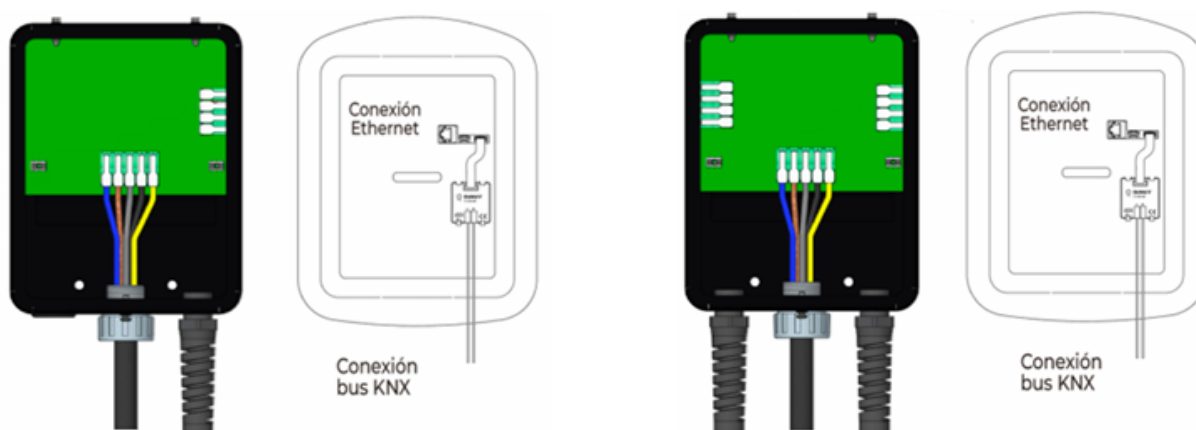

# ETS CONFIGURATION

## Configuration parameters

### General

On this initial screen, it is possible to set a series of general settings

The options available on this screen are as follows:

- **Delay at start:** selects the time that must elapse before sending telegrams to the KNX bus begins.
- **OCPP mode activated:** OCPP (Open Charge Point Protocol) is a system that makes the charger compatible with any payment operator. It enables control via OCPP systems. Through the 1-byte object 35, the charger status (DPT 20.1220) can be monitored via the KNX bus. After selecting this option, the options under “Charging Session Time,” “Installation,” “Limits,” and “Dynamic Load Balancing” will no longer be visible.

#### Model Features:

- **Phase number:** allows selecting the number of supply phases of the model to be configured. If Three-phase is selected, the “Installation” and “Limits” sections will be configurable for each phase. However, the Dynamic Load Balancing option will only be available if Single-phase is selected.
- **Number of EVSE Connectors:** the option corresponding to the purchased Charger model must be selected. In the case of selecting “Single-phase” and “2 Connectors”:

- **Phase connection:** it must be selected whether both connectors will be powered from the same phase or from different phases.

---

### Charging session time:

- **Maximum charging session time:** allows setting whether EV charging will always be on, or limiting the session time (up to 6 hours).
- **Auto-disconnect after charging:** when this option is enabled, automatic disconnection of the connector locking system is allowed after the charging session. If disabled, voluntary unlocking can be performed through the “[Conn1] Connector unlock” object.

65	[Conn1] Connector unlock	1: Connector unlock trigger	1 bit	C	-	W	-	-	trigger	Low
----	--------------------------	-----------------------------	-------	---	---	---	---	---	---------	-----

- **Auto-start charging on connect:** allows the vehicle to start charging automatically immediately after being connected to the connector.

### Installation:

- **Contracted Power:** the total contracted power of the household sharing the supply line must be set so that the charger can account for the maximum power it can provide.
- **Maximum User Current:** if for any reason (vehicle incompatibilities, installations not rated for 32 A, etc.) it is necessary to reduce the maximum current, a more appropriate value can be selected for the specific installation. The minimum allowed is 6 A.

### Limits:

- **Limit by Active Power:** sets whether the limit will be determined by current or by active power (default).
- **Initial Total Active Power limit / Initial Total Current limit:** if in the previous parameter the “Limit by Active Power” option is selected, a value (W) can be set to limit the active power to the desired level. Conversely, if the option is disabled, a value (A) can be set to limit the current.

### Dynamic Load Balancing:

- **Enable Dynamic Load Balancing:** after selecting this option, the “Load Balancing” tab will appear. This option is only available if the charger is Single-phase, not Three-phase. See the “Load Balancing” section.

## Status Sending

In this menu, it is possible to configure the transmission of different status objects. Each transmission refers to the status communication objects of the corresponding connector, listed in the final object table:

- General	
General	
<b>Status Sending</b>	
Advanced	
- Connector	
Connector 1	
Connector 2	
+ Load balancing	

<b>Current</b>	
Current sending	Upon change
Current value change	1 A
<b>Active Power</b>	
Active Power sending	Upon change
Active Power value change	250 W
<b>Session Energy</b>	
Energy sending	Upon change
Energy value change	100 Wh
<b>Session Time</b>	
Time sending	Upon change
Time value change	30 sec
<b>Charging Status</b>	
Charging Status sending	Upon change

### Current:

- **Current sending:** configures the transmission of the instantaneous current objects of the corresponding connector. In single-phase mode, the instantaneous single-phase current is used (for example, object 48 for Connector 1 and object 97 for Connector 2); in three-phase mode, currents L1/L2/L3 are used (objects 49-51 for Connector 1 and 98-100 for Connector 2).

Current sending	Upon change
Current value change	Upon change ✓ Cyclically Upon change and cyclically

- **Upon change:** the current will be sent after a change in its value exceeding the threshold set in “Current value change.”
- **Cyclically:** the current will be sent at each interval set in “Current transmission period.”
- **Upon change and cyclically:** the current will be sent after a change in its value exceeding the threshold set in “Current value change” and at each interval set in “Current transmission period.”
- **Current value change:** the value that must be exceeded to trigger transmission.
- **Current transmission period:** the interval at which the current value is sent.

### Active Power:

- **Active Power sending:** configures the transmission of the instantaneous active power of the corresponding connector (object 47 for Connector 1 and object 96 for Connector 2).

Active Power	
Active Power sending	Upon change
Active Power value change	<ul style="list-style-type: none"> <li>Upon change ✓</li> <li>Cyclically</li> <li>Upon change and cyclically</li> </ul>

- **Upon change:** the power will be sent after a change in its value exceeding the threshold set in “Active Power value change.”
  - **Cyclically:** the power will be sent at each interval set in “Active Power transmission period.”
  - **Upon change and cyclically:** the power will be sent after a change in its value exceeding the threshold set in “Active Power value change” and at each interval set in “Active Power transmission period.”
- **Active Power value change:** the value that must be exceeded to trigger transmission.
  - **Active Power transmission period:** the interval at which the active power value is sent.

Session Energy:

- **Energy sending:** configures the transmission of the energy of the current session (object 46 for Connector 1 and object 95 for Connector 2).

Session Energy	
Energy sending	Upon change
Energy value change	<ul style="list-style-type: none"> <li>Upon change ✓</li> <li>Cyclically</li> <li>Upon change and cyclically</li> </ul>

- **Upon change:** the energy will be sent after a change in its value exceeding the threshold set in “Energy value change.”
  - **Cyclically:** the energy will be sent at each interval set in “Energy transmission period.”
  - **Upon change and cyclically:** the energy will be sent after a change in its value exceeding the threshold set in “Energy value change” and at each interval set in “Energy transmission period.”
- **Energy value change:** the value that must be exceeded to trigger transmission.
  - **Energy transmission period:** the interval at which the session energy value is sent.

Session Time:

- **Time sending:** configures the transmission of the current session time (object 45 for Connector 1 and object 94 for Connector 2).

Session Time	
Time sending	Upon change
Time value change	<ul style="list-style-type: none"> <li>Upon change ✓</li> <li>Cyclically</li> <li>Upon change and cyclically</li> </ul>

- **Upon change:** the session time will be sent after a change in its value exceeding the threshold set in “Time value change.”

- **Cyclically:** the session time will be sent at each interval set in “Time transmission period.”
- **Upon change and cyclically:** the session time will be sent after a change in its value exceeding the threshold set in “Time value change” and at each interval set in “Time transmission period.”
- **Time value change:** the value that must be exceeded to trigger transmission.
- **Time transmission period:** the interval at which the session time value is sent.

Charging Status:

- **Charging Status sending:** configures the transmission of the charger status of the corresponding connector: Pilot State (objects 34/83), OCPP State (objects 35/84) and, if the individual status objects are enabled, the vehicle connected, charging, available, suspended, finished, reserved, unavailable and fault objects.

**Charging Status**

Charging Status sending

Upon change ▼

Upon change ✓

Cyclically

Upon change and cyclically

- **Upon change:** the charging status will be sent after any change in its value.
- **Cyclically:** the charging status will be sent at each interval set in “Charging Status transmission period.”
- **Upon change and cyclically:** the charging status will be sent after any change in its value and at each interval set in “Charging Status transmission period.”
- **Charging status transmission period:** the interval at which the charging status value is sent.

## Advanced

In this menu, it is possible to enable another set of communication objects:

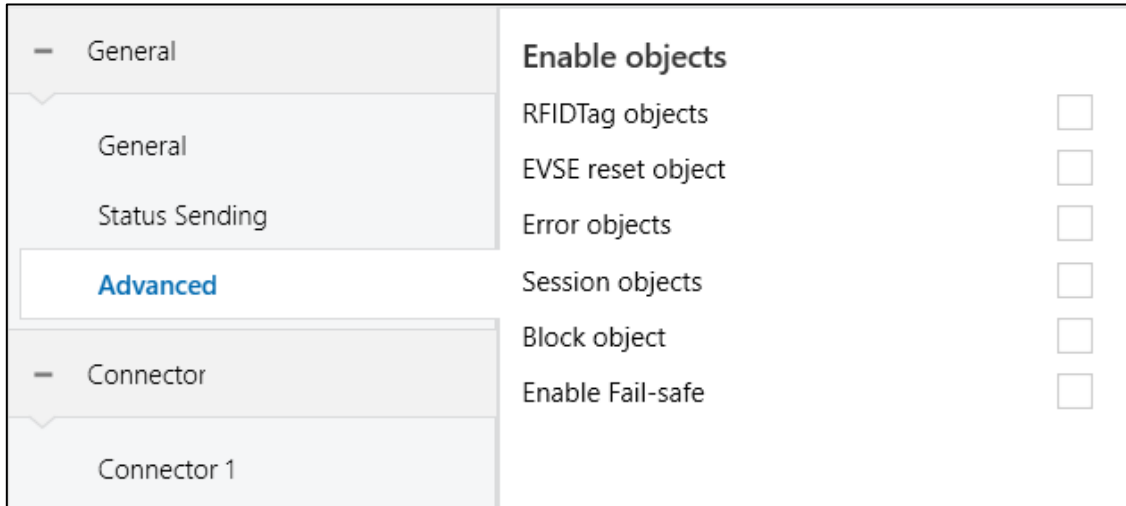

- **RFIDTag objects:** enables the following objects for RFID identification:
  - **Add RFIDTag authorization:** this object allows storing new RFID addresses to enable access with different cards. To add an authorization, the RFIDTag card identifier must be sent to the “[EVSE] Add RFIDTag authorization” object (object 8, 14 bytes, DPT 16.001).
  - **Erase all authorized RFIDTags:** allows deleting all cards stored in the system.

8	[EVSE] Add RFIDTag authorization	RFIDTag ID	14 bytes	C - W - -	Character...	Low
9	[EVSE] Erase all authorized RFIDTags	1: erase all, 0: nothing	1 bit	C - W - -	trigger	Low

- **EVSE Reset object:** enables the charger reset object. Sending a 1 to the “[EVSE] Reset” object (object 5) restarts the charger and restores its internal operating states, session values and active errors. It does not delete the ETS parameterization or the authorized RFIDTags.

5	[EVSE] Reset	Charger Reset	1 bit	C - W - -	reset	Low
---	--------------	---------------	-------	-----------	-------	-----

- **Error objects:** enables the following charger error objects:
  - **Error code:** each time the charger reports an error, it shows a code that allows the error to be identified according to DPT 20.1221 EVSEErrorCode. Main values: 1 = Connector Lock Failure, 2 = EV Communication Error, 3 = Ground Failure, 4 = High Temperature, 5 = Internal Error, 6 = Local List Conflict, 7 = NoError; 8-255 = reserved.
  - **Communication error with EVSE:** this object takes the value 1 when an error is detected and 0 if there is no error.

19	[EVSE] Error code	Error code	1 byte	C R - T -	EVSEErrorCode	Low
20	[EVSE] Communication error with EVSE	1: error, 0: no error	1 bit	C R - T -	alarm	Low

- **Session objects:** enables the following objects related to the charging session:
  - **Maximum Charging session:** allows setting the maximum session time in seconds.
  - **Auto disconnect after Charging session:** at the end of the session, the charger will disconnect automatically if this option is selected.
  - **Auto charging init after connect:** if this object is enabled, charging will start automatically when the vehicle is connected.

6	[EVSE] Maximum Charging session	seconds	2 bytes	C - W - -	time (s)	Low
7	[EVSE] Auto disconnect after chargin...	1: auto, 0: no auto	1 bit	C - W - -	enable	Low
13	[EVSE] Instantaneous Active Power	Watts	4 bytes	C R - T -	power (W)	Low
14	[EVSE] Instantaneous Single-phase C...	Amps	4 bytes	C R - T -	electric current (...)	Low
26	[EVSE] Auto charging init after connect	1: auto, 0: no auto	1 bit	C - W - -	enable	Low

- **Block object:** enables the charger block object. Sending 1 blocks the charger and prevents new charging sessions from being started via KNX; sending 0 unblocks it and allows charging again according to the remaining configured conditions.

25	[EVSE] Block	1: block, 0: unblock	1 bit	C - W - -	switch	Low
----	--------------	----------------------	-------	-----------	--------	-----

- **Enable Fail-safe:** allows activating Fail-safe mode, which describes the state in which the device loses connection with the HEMS. If no signal is detected at the function block inputs during the time set in the FailSafeTimeout parameter, communication with the HEMS is considered lost. As a result, the Fail-safe current or power values are set as new limits in the device. The Fail-safe feedback objects are used to display the loss of communication with the HEMS in the KNX installation. After enabling it:

Enable Fail-safe

**Fail-safe conditions**

Fail-safe Timeout  sec

Fail-safe objects

- **Fail-safe wait time:** the time (in seconds) after which the programmed Fail-safe objects or actions will be activated.
- **Fail-safe objects:** enables the charger's Fail-safe status object.

10	[EVSE] Fail-safe Status	1: active, 0: no active	1 bit	C R - T -	boolean	Low
----	-------------------------	-------------------------	-------	-----------	---------	-----

## Connector

It is possible to configure one or two connectors, depending on the model.

Within the “Connector 1” or “Connector 2” configurations, the following options can be selected:

<ul style="list-style-type: none"><li>General</li></ul>	<h3>Limits</h3> <p>Initial Active Power limit <input type="text" value="3500"/> W</p> <div><p><b>i</b> Load balancing between connectors: the total available power will be split 50/50 if two cars are connected, and the full available power will be supplied to a single connector if only one car is connected</p></div>
<ul style="list-style-type: none"><li>General</li><li>Status Sending</li><li>Advanced</li></ul>	
<ul style="list-style-type: none"><li>Connector</li></ul>	<h3>Charging Status</h3> <p>Send Charger Status at init <input type="checkbox"/></p> <p>Charger OCPP State <input checked="" type="checkbox"/></p> <p>Charger Pilot State <input type="checkbox"/></p> <p>Charger Status individual objects <input type="checkbox"/></p> <h3>Enable objects</h3> <p>Charging Time Interval objects <input type="checkbox"/></p> <p>Block object <input type="checkbox"/></p>
<ul style="list-style-type: none"><li>Connector 1</li><li>Connector 2</li></ul>	

### Limits:

- **Initial Active Power limit:** this option allows setting the active power limit at which the chargers will charge. The power will be divided 50% if two connectors are connected at the same time. If only one connector is operating, that connector will receive 100% of the available power. If the available power is limited by this parameter, the charger will receive the configured limit. In two-connector models, if the Connector 1 limit differs from the Connector 2 limit, each connector will respect its own limit and the distribution will be carried out without exceeding either configured value.

### Charging status:

- **Send Charger States at init:** normally, charging status objects are sent when the object state is updated according to the established limits or cyclically as configured. When the “Send Charger States at init” option is selected, the configured status objects will be sent every time the charger is initialized: OCPP State, Pilot State and, if enabled, the individual status objects (vehicle connected, charging, charger available, charging suspended by EV, charging suspended by EVSE, charging finished, charger reserved, charger unavailable and fault).
- **Charger OCPP State:** allows viewing the charger status via DPT 20.1220 OCPP State. Values: 0 = Charging, 1 = EVConnected, 2 = SuspendedEV, 3 = SuspendedEVSE, 4 = Idle, 5 = Available, 6 = Occupied, 7 = Reserved, 8 = Unavailable, 9 = Faulted; 10-255 = reserved.
- **Charger Pilot State:** shows the control pilot status via DPT 20.1219 Control Pilot State. Values: 0 = Standby, 1 = Vehicle Detected, 2 = Ready charging, 3 = Charging with ventilation, 4 = Finished, 5 = Reserved for specific EV, 6 = Unavailable, 7 = ERROR, 8 = Suspended\_EV\_SE, 9 = Suspended\_EV; 10-255 = reserved.
- **Charger Status individual objects:** allows enabling individual objects related to the status of the charger connector.

36	[Conn1] Vehicle connected	1: connected	1 bit	C	R	-	T	-	boolean	Low
37	[Conn1] Charging	1: charging	1 bit	C	R	-	T	-	state	Low
38	[Conn1] Charger available	1: Charger available	1 bit	C	R	-	T	-	boolean	Low
39	[Conn1] Charging suspended by EV	1: Charging suspended b...	1 bit	C	R	-	T	-	boolean	Low
40	[Conn1] Charging suspended by EVSE	1: Charging suspended b...	1 bit	C	R	-	T	-	boolean	Low
41	[Conn1] Charging finished	1: finished	1 bit	C	R	-	T	-	boolean	Low
42	[Conn1] Charger reserved	1: reserved	1 bit	C	R	-	T	-	boolean	Low
43	[Conn1] Charger unavailable	1: unavailable	1 bit	C	R	-	T	-	boolean	Low
44	[Conn1] Charger fault	1: fault	1 bit	C	R	-	T	-	boolean	Low

#### Enable objects:

- **Charging Time Interval objects:** activates communication objects that allow enabling or disabling charging schedules. Charging schedules can only be configured through the Dinuy – eMobility app or via the Cloud web platform over Wi-Fi or Ethernet. Using ETS® software, it is only possible to enable or disable these charging schedules.

54	[Conn1] Enable/Disable charging tim...	1: enable, 0: disable	1 bit	C	-	W	-	-	enable	Low
57	[Conn1] Enable/Disable charging tim...	1: enable, 0: disable	1 bit	C	-	W	-	-	enable	Low
60	[Conn1] Enable/Disable charging tim...	1: enable, 0: disable	1 bit	C	-	W	-	-	enable	Low

- **Block object:** activates a communication object that allows blocking communication with the charger via KNX.

## Dynamic Load Balancing

Dynamic load balancing is a feature integrated into this range of chargers, designed to automatically regulate charging power based on the consumption of the other chargers connected to the system. In KNX configurations, using information from an external energy meter, the device determines the total power available for charging and, through the balancing system, distributes this power among the electric vehicle chargers (EVSE) that are in operation.

Models equipped with the protections VE 741 SP0, VE 741 MP5, and VE 741 MP1 and the single-phase VE 741 M05, VE 741 M10 and VE 741 S00 models include a current clamp that allows for real-time measurement of the total current consumed by the installation. In these models, the measurement obtained by the clamp is sent directly to a single charger, which adjusts its charging power according to the available current. This operating mode allows for dynamic balancing that takes into account the building's consumption, but only for a single charger. This system is independent of KNX balancing and does not distribute power among multiple chargers.

For example, in an installation with a contracted power of 4.4 kW, if during the charging process an appliance with a consumption of up to 2 kW is connected (for example, a washing machine during the heating phase), the charger will detect that only approximately 2.4 kW are available and will automatically reduce the charging power to avoid exceeding the contracted limit, ensuring safe operation and preventing the installation protection devices from tripping.

### Dynamic load balancing with solar generation

In installations with photovoltaic generation, dynamic load balancing does not require a different configuration. The current clamp or energy meter must be installed at the incoming supply measuring point, downstream of the meter, so that it measures the net power balance between the installation and the electricity grid.

When the photovoltaic inverter generates energy, this generation reduces the net consumption measured at the incoming supply. If generation exceeds the building consumption, the measured value is interpreted as negative power, corresponding to energy exported to the grid. When calculating the power available for charging, this contribution increases the power that the system can assign to the charger or chargers, while always respecting the configured limits and the established reserve margin.

In this way, the charger can use the available solar surplus to dynamically increase the vehicle charging power. If solar production decreases or the installation consumption increases, the system will automatically reduce the charging power to avoid exceeding the contracted limit or the configured protection limit.

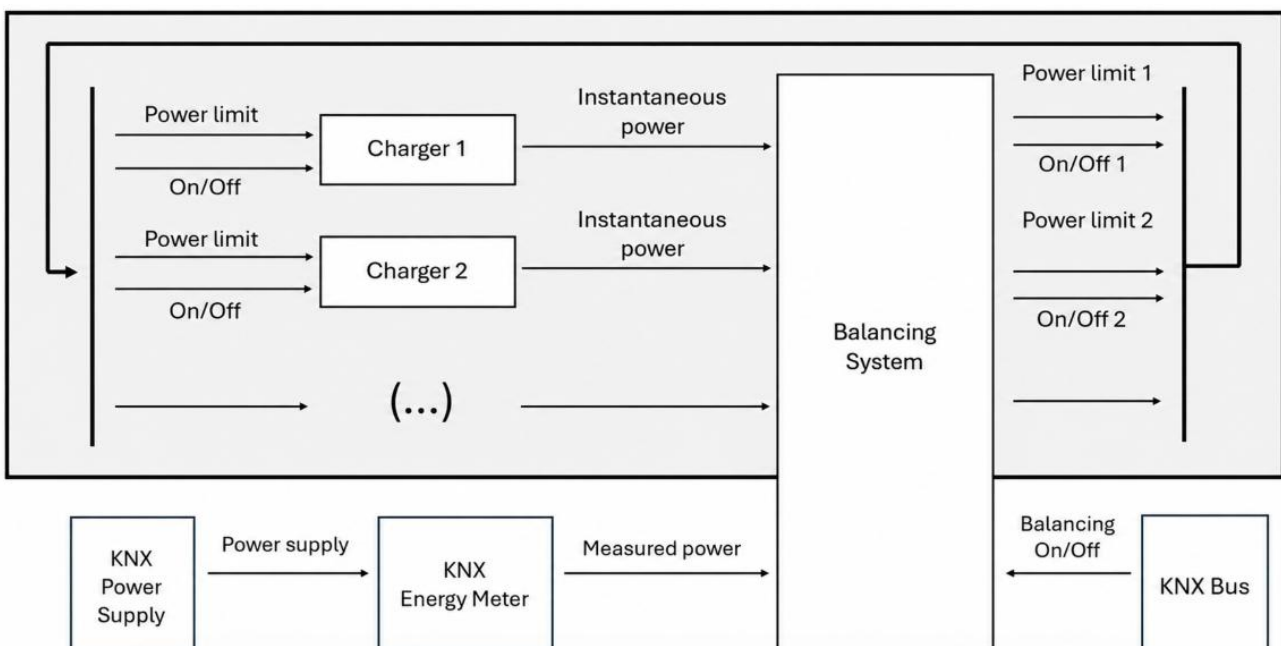

---

This system operates in a master-slave configuration, with the balancing system of Charger 1 assigned as the master. The remaining chargers, up to a maximum of 5 additional units (6 in total), are connected as slaves. This prioritizes the charging system in an order of precedence. If at any time the available power is insufficient to maintain charging for all EVSEs simultaneously, the balancing system will sequentially disconnect chargers starting with EVSE6 (least priority), then EVSE5, EVSE4, etc., until the available power divided among all stations is sufficient to ensure the charging of connected vehicles.

For all of the above, it is possible to limit the charging capacity in both power and current to facilitate system configuration. This ensures that charging never exceeds critical values for the system.

### Dynamic balancing in models with two connectors

Balancing between the two connectors of the charger is performed automatically with simple logic:

- If only one vehicle is connected to connector A or connector B, the charger will supply the maximum configured power, which can be up to 22 kW in the three-phase version or up to 7.4 kW in the single-phase version.
- When a second vehicle is connected to the other connector, the available power is split between the two, assigning 50% of the maximum configured power to each connector.
- If one of the vehicles does not fully use its assigned power, the surplus is not transferred to the other vehicle, keeping the 50% limit for each connector.

**Special case in single-phase installations with dual phase:** in the single-phase model there is a particular case, since the charger can be used in installations with two different phases (two-phase), where connector A is powered from one phase and connector B from another phase.

In this operating mode, balancing between connectors can be disabled by configuration, allowing the charger to supply up to 7.4 kW to each connector simultaneously. For this reason, the dual-connector single-phase charger has a 5-pole terminal block. See the “Connection diagram” section for the corresponding installation diagrams.

### Dynamic balancing between multiple units

To perform balancing between multiple units, the KNX communication system must be used, just as it can be used to limit the power of a single charger when the electrical consumption of a building or smart home requires it. This dynamic balancing function from ETS® is available for single-phase models. For this reason, this configuration can be done using ETS® software (ETS5 or later). To do this, the “Enable Dynamic Load Balancing” option must be selected from the “General” tab in the configuration menu.

After enabling the option, the “Load Balancing” tab will appear in the menu. The maximum number of units that can be balanced is 6 EVSEs. The system operates in a master-slave configuration in which one charger manages the power of the others. Since up to 6 chargers can be balanced simultaneously, the priority order is from EVSE1 to EVSE6. This means that if the available power for all units is insufficient to meet the minimum required for charging, the units will be disconnected sequentially (EVSE6, EVSE5, EVSE4, etc.) until the available power is sufficient to start charging.

It is also possible to set a different maximum current (A) for each charger if the charging of a specific unit is to be prioritized. This current limit can also be replaced by a power limit (W) if desired. This option is accessible if the “Current Control” option in the “Load Balancing” tab is disabled.



If the “Enable Dynamic Load Balancing” option is selected in the “General” tab, this new option will become available in the menu:

General	Balancing after initializing KNX Bus	Off
General	Balancing transmission period	10 sec (0 = no send)
Status Sending	<b>Limits</b>	
Advanced	Current control	<input checked="" type="checkbox"/>
Connector	Overcurrent protection device	63 A
Connector 1	Load reserve margin	10 %
Connector 2	<b>EVSE to balance</b>	
Load balancing	Number of EVSE to balance	1
Load balancing	<div style="border: 1px solid #ccc; padding: 5px; background-color: #e6f2ff;"> <p><b>i</b> Priority ordered from highest to lowest EVSE1 -&gt; EVSE6, applied when the minimum is not reached for all</p> </div>	
Load balancing	<b>EVSE 1</b>	
Load balancing	Maximum Current EVSE1	32 A

- **Balancing after initializing KNX bus:** sets the state of this function after the KNX bus power is restored.

Balancing after initializing KNX Bus	Off
Balancing transmission period	Off <input checked="" type="checkbox"/>
	On
	Last State

- **Balancing transmission period:** time, in seconds, for the periodic transmission of the “[Balancing] On / Off” object status (object 132) and the configured balancing values. If set to 0, the value will be sent only when it changes.

#### Limits:

- **Current control:** allows setting a limit to restrict the maximum current. If this option is disabled, the limit will be set by power, allowing selection of the contracted power and maximum active power.
- **Overcurrent protection device / Contracted power:** depending on the “Current Control” selection, one or the other will be available. If “Current Control” is enabled, the overcurrent protection device current limit (A) is set. If it is disabled, the available contracted power (W) is set. This value is the maximum reference that the balancing system must not exceed.
- **Load reserve margin:** allows setting a safety margin to prevent reaching the maximum limit. For example, with a 63 A protection device and a 10% margin, the system will reserve 6.3 A and calculate balancing on a maximum of 56.7 A.
- **Number of EVSE to balance:** allows selecting the number of chargers to balance. When this option is greater than 1, the system configures a master/slave scheme, assigning different priorities to the remaining charging stations (EVSEs). This means that the highest-priority charger will be EVSE1, followed by EVSE2, and so on, up to the maximum number of available chargers.
- **Maximum current EVSE1\_6 / Maximum active power EVSE1\_6:** allows limiting the maximum current or power for each charger. There will be as many options as chargers to balance, and for each one, a maximum current or power can be set. If, for any reason, the available power is insufficient to ensure simultaneous

charging of all chargers, the lower-priority chargers (EVSE6, EVSE5, etc.) will be disconnected sequentially until the available power is sufficient to maintain charging.

### Example of load balancing configuration in KNX:

The load balancing system is based on the continuous exchange of information through KNX group addresses.

The following describes the parameterization of a dynamic load balancing system using KNX. In this type of configuration, one of the chargers (EVSE) acts as the Master, responsible for centralizing the calculation and distribution of the available current among the remaining chargers, which operate as Slaves.

The EVSE Master receives:

- The total measured current of the system
- The instantaneous current of each charger

Based on this data, it calculates the available current and dynamically redistributes the charging limits among the EVSEs, ensuring that the maximum system capacity is not exceeded.

To configure it, first select the charger that will act as the Master and activate the “Enable Dynamic Load Balancing” option for it.

1.1.2 Cargador VE Esclavo > General > General

General	Delay in start	2	sec
General	OCPP mode activated	<input type="checkbox"/>	
Status Sending	<b>Model features</b>		
Advanced	Phase number	<input checked="" type="radio"/> Single-phase <input type="radio"/> Three-phase	
+ Connector	Number of EVSE Connectors	<input checked="" type="radio"/> 1 Connector <input type="radio"/> 2 Connectors	
+ Load balancing	<b>Charging session Time</b>		
	Maximum charging session time	Always ON	min
	Auto-disconnect after charging	<input checked="" type="checkbox"/>	
	Auto-start charging on connect	<input type="checkbox"/>	
	<b>Installation</b>		
	Contracted Power	9200	W
	Maximum User Current	32	A
	<b>Limits</b>		
	Limit by Active Power	<input type="checkbox"/>	
	Initial Total Current limit	15	A
	<b>Dynamic Load Balancing</b>		
	Enable Dynamic Load Balancing	<input checked="" type="checkbox"/>	



Subsequently, in the “Load Balancing” tab, the total number of EVSEs that will participate in the balancing system (up to 6) must be defined.

**1.1.2 Cargador VE Esclavo > Load balancing**

General

Balancing after initializing KNX Bus: Off

Balancing transmission period: 10 sec (0 = no send)

**Limits**

Current control:

Overcurrent protection device: 63 A

Load reserve margin: 10 %

**EVSE to balance**

Number of EVSE to balance: 2

*Priority ordered from highest to lowest EVSE1 -> EVSE6, applied when the minimum is not reached for all*

**EVSE 1**

Maximum Current EVSE1: 32 A

**EVSE 2**

Maximum Current EVSE2: 32 A

With this configuration (2), one EVSE Master and one EVSE Slave will be available.

This will enable the following objects on the EVSE Master:

130	[Balancing] Current measured	A	Lectura medidor corriente	0/0/1	4 bytes	C - W - -	electric cu... Low
132	[Balancing] Switch On/Off	1: On; 0: Off			1 bit	C - W - -	switch Low
133	[Balancing-EVSE1] Instantaneous Single-phase Curr... Amps	Amps	Lectura intensidad EVSE1	0/0/2	4 bytes	C - W - -	electric cu... Low
135	[Balancing-EVSE1] Current limit	Amps	Límite asignado a EVSE1	0/0/4	4 bytes	C R - T -	electric cu... Low
137	[Balancing-EVSE1] Pause/Restart charging	Start / Stop	Pausar/reanudar EVSE1	0/0/6	1 bit	C R - T -	start/stop Low
148	[Balancing-EVSE2] Instantaneous Single-phase Curr... Amps	Amps	Lectura intensidad EVSE2	0/0/3	4 bytes	C - W - -	electric cu... Low
150	[Balancing-EVSE2] Current limit	Amps	Límite asignado a EVSE2	0/0/5	4 bytes	C R - T -	electric cu... Low
152	[Balancing-EVSE2] Pause/Restart charging	Start / Stop	Pausar/reanudar EVSE2	0/0/7	1 bit	C R - T -	start/stop Low

The following is a proposed Group Address structure for an installation with 2 chargers (Master + Slave):

Address ▲	Name	Description	Central	Data Type	Length	No. of	Last Value
0/0/1	Current meter reading		No	electric current (A)	4 bytes	1	
0/0/2	EVSE1 intensity reading		No	electric current (A)	4 bytes	2	
0/0/3	EVSE2 intensity reading		No	electric current (A)	4 bytes	2	
0/0/4	EVSE1 assigned limit		No	electric current (A)	4 bytes	2	
0/0/5	EVSE2 assigned limit		No	electric current (A)	4 bytes	2	
0/0/6	Pause/Resume EVSE1		No	start/stop	1 bit	2	
0/0/7	Pause/Resume EVSE2		No	start/stop	1 bit	2	

- 0/0/1 Current meter reading: in addition to the EVSE Master’s “[Balancing] Measured Current” object, this GA must also be associated with the total current measured by the system (for example, using a KNX Energy Meter). This value is used by the EVSE Master to calculate the available power.

130	[Balancing] Current measured	A	Current meter reading	0/0/1	4 bytes	C - W - -	electric cu... Low
-----	------------------------------	---	-----------------------	-------	---------	-----------	--------------------

- 0/0/2 EVSE1 current reading: in this GA, the instantaneous single-phase current of the EVSE Master is linked to the corresponding object of the balancing system. EVSE1 acts as the system Master, centralizing the balancing control logic.

14	[EVSE] Instantaneous Single-phase Current	Amps	EVSE1 intensity reading	0/0/2	4 bytes	C	R	-	T	-	electric cu...	Low
33	[Conn1] Start - Stop charging	Start / Stop			1 bit	C	-	W	-	-	start/stop	Low
35	[Conn1] Charger Status - OCPP State	OCPP Status			1 byte	C	-	-	T	-	OCPP State	Low
45	[Conn1] Current session time	seconds			2 bytes	C	-	-	T	-	time (s)	Low
46	[Conn1] Current session Energy	Wh			4 bytes	C	-	-	T	-	active ene...	Low
65	[Conn1] Connector unlock	1: Connector unlock...			1 bit	C	-	W	-	-	trigger	Low
67	[Conn1] RFIDTag charging started	RFIDTag ID			14 bytes	C	-	-	T	-	Character...	Low
130	[Balancing] Current measured	A			4 bytes	C	-	W	-	-	electric cu...	Low
132	[Balancing] Switch On/Off	1: On; 0: Off			1 bit	C	-	W	-	-	switch	Low
133	[Balancing-EVSE1] Instantaneous Single-phase Curr...	Amps	EVSE1 intensity reading	0/0/2	4 bytes	C	-	W	-	-	electric cu...	Low

- 0/0/3 EVSE2 current reading: in this GA, the current measured in the EVSE Slave is linked to the corresponding balancing object of the EVSE Master.

14	[EVSE] Instantaneous Single-phase Current	Amps	EVSE1 intensity reading	0/0/2	4 bytes	C	R	-	T	-	electric cu...	Low
33	[Conn1] Start - Stop charging	Start / Stop			1 bit	C	-	W	-	-	start/stop	Low
35	[Conn1] Charger Status - OCPP State	OCPP Status			1 byte	C	-	-	T	-	OCPP State	Low
45	[Conn1] Current session time	seconds			2 bytes	C	-	-	T	-	time (s)	Low
46	[Conn1] Current session Energy	Wh			4 bytes	C	-	-	T	-	active ene...	Low
65	[Conn1] Connector unlock	1: Connector unlock...			1 bit	C	-	W	-	-	trigger	Low
67	[Conn1] RFIDTag charging started	RFIDTag ID			14 bytes	C	-	-	T	-	Character...	Low
130	[Balancing] Current measured	A			4 bytes	C	-	W	-	-	electric cu...	Low
132	[Balancing] Switch On/Off	1: On; 0: Off			1 bit	C	-	W	-	-	switch	Low
133	[Balancing-EVSE1] Instantaneous Single-phase Curr...	Amps	EVSE1 intensity reading	0/0/2	4 bytes	C	-	W	-	-	electric cu...	Low
135	[Balancing-EVSE1] Current limit	Amps	EVSE1 assigned limit	0/0/4	4 bytes	C	R	-	T	-	electric cu...	Low
137	[Balancing-EVSE1] Pause/Restart charging	Start / Stop	Pause/Resume EVSE1	0/0/6	1 bit	C	R	-	T	-	start/stop	Low
148	[Balancing-EVSE2] Instantaneous Single-phase Curr...	Amps	EVSE2 intensity reading	0/0/3	4 bytes	C	-	W	-	-	electric cu...	Low

- 0/0/4 EVSE1 assigned limit: in this GA, the current limits applicable to the EVSE Master are established according to the balancing parameterization performed.

### 1.1.1 Cargador VE Maestro > Load balancing

- General
- General
- Status Sending
- Advanced
- Connector
- Load balancing

Balancing after initializing KNX Bus: Off

Balancing transmission period: 10 sec (0 = no send)

**Limits**

Current control:

Overcurrent protection device: 63 A

Load reserve margin: 10 %

**EVSE to balance**

Number of EVSE to balance: 2

*Priority ordered from highest to lowest EVSE1 -> EVSE6, applied when the minimum is not reached for all*

**EVSE 1**

Maximum Current EVSE1: 32 A

**EVSE 2**

Maximum Current EVSE2: 32 A

1	[EVSE] Current limit	Total Amps	EVSE1 assigned limit	0/0/4	4 bytes	C	-	W	-	-	electric cu...	Low
3	[EVSE] Current limit Status	Total Amps			4 bytes	C	R	-	T	-	electric cu...	Low
13	[EVSE] Instantaneous Active Power	Watts			4 bytes	C	R	-	T	-	power (W)	Low
14	[EVSE] Instantaneous Single-phase Current	Amps	EVSE1 intensity reading	0/0/2	4 bytes	C	R	-	T	-	electric cu...	Low
33	[Conn1] Start - Stop charging	Start / Stop			1 bit	C	-	W	-	-	start/stop	Low
35	[Conn1] Charger Status - OCPP State	OCPP Status			1 byte	C	-	-	T	-	OCPP State	Low
45	[Conn1] Current session time	seconds			2 bytes	C	-	-	T	-	time (s)	Low
46	[Conn1] Current session Energy	Wh			4 bytes	C	-	-	T	-	active ene...	Low
65	[Conn1] Connector unlock	1: Connector unlock...			1 bit	C	-	W	-	-	trigger	Low
67	[Conn1] RFIDTag charging started	RFIDTag ID			14 bytes	C	-	-	T	-	Character...	Low
130	[Balancing] Current measured	A			4 bytes	C	-	W	-	-	electric cu...	Low
132	[Balancing] Switch On/Off	1: On; 0: Off			1 bit	C	-	W	-	-	switch	Low
133	[Balancing-EVSE1] Instantaneous Single-phase Curr...	Amps	EVSE1 intensity reading	0/0/2	4 bytes	C	-	W	-	-	electric cu...	Low
135	[Balancing-EVSE1] Current limit	Amps	EVSE1 assigned limit	0/0/4	4 bytes	C	R	-	T	-	electric cu...	Low

- 0/0/5 EVSE2 assigned limit: in this GA, the current limits applicable to the EVSE Slave are established according to the balancing parameterization performed:

### 1.1.1 Cargador VE Maestro > Load balancing

- General
- General
- Status Sending
- Advanced
- Connector
- Load balancing

Balancing after initializing KNX Bus: Off

Balancing transmission period: 10 sec (0 = no send)

**Limits**

Current control:

Overcurrent protection device: 63 A

Load reserve margin: 10 %

**EVSE to balance**

Number of EVSE to balance: 2

**EVSE 1**

Maximum Current EVSE1: 32 A

**EVSE 2**

Maximum Current EVSE2: 32 A

Objeto *	Dispositivo	Envío activo	Tipo de Datos	C	R	W	T	U	Longitud	Prioridad
1: [EVSE] Intensidad límite - Amperios Totales	1.5.2 Cargador VE Esclavo	S	electric current (A)	C	-	W	-	-	4 bytes	Bajo
150: [Balanceo-EVSE2] Intensidad límite - Amperios	1.5.1 Cargador VE Maestro	S	electric current (A)	C	R	-	T	-	4 bytes	Bajo

- 0/0/6 Pause/Resume EVSE1: allows starting or pausing EVSE Master charging based on the balancing calculation.

33	[Conn1] Start - Stop charging	Start / Stop			1 bit	C	-	W	-	-	start/stop	Low
35	[Conn1] Charger Status - OCPP State	OCPP Status			1 byte	C	-	-	T	-	OCPP State	Low
45	[Conn1] Current session time	seconds			2 bytes	C	-	-	T	-	time (s)	Low
46	[Conn1] Current session Energy	Wh			4 bytes	C	-	-	T	-	active ene...	Low
65	[Conn1] Connector unlock	1: Connector unlock...			1 bit	C	-	W	-	-	trigger	Low
67	[Conn1] RFIDTag charging started	RFIDTag ID			14 bytes	C	-	-	T	-	Character...	Low
130	[Balancing] Current measured	A			4 bytes	C	-	W	-	-	electric cu...	Low
132	[Balancing] Switch On/Off	1: On; 0: Off			1 bit	C	-	W	-	-	switch	Low
133	[Balancing-EVSE1] Instantaneous Single-phase Curr...	Amps	EVSE1 intensity reading	0/0/2	4 bytes	C	-	W	-	-	electric cu...	Low
135	[Balancing-EVSE1] Current limit	Amps	EVSE1 assigned limit	0/0/4	4 bytes	C	R	-	T	-	electric cu...	Low
137	[Balancing-EVSE1] Pause/Restart charging	Start / Stop	Pause/Resume EVSE1	0/0/6	1 bit	C	R	-	T	-	start/stop	Low

- 0/0/7 Pause/Resume EVSE2: allows starting or pausing EVSE Slave charging based on the balancing calculation.

33	[Conn1] Start - Stop charging	Start / Stop			1 bit	C	-	W	-	-	start/stop	Low
35	[Conn1] Charger Status - OCPP State	OCPP Status			1 byte	C	-	-	T	-	OCPP State	Low
45	[Conn1] Current session time	seconds			2 bytes	C	-	-	T	-	time (s)	Low
46	[Conn1] Current session Energy	Wh			4 bytes	C	-	-	T	-	active ene...	Low
65	[Conn1] Connector unlock	1: Connector unlock...			1 bit	C	-	W	-	-	trigger	Low
67	[Conn1] RFIDTag charging started	RFIDTag ID			14 bytes	C	-	-	T	-	Character...	Low
130	[Balancing] Current measured	A			4 bytes	C	-	W	-	-	electric cu...	Low
132	[Balancing] Switch On/Off	1: On; 0: Off			1 bit	C	-	W	-	-	switch	Low
133	[Balancing-EVSE1] Instantaneous Single-phase Curr... Amps	EVSE1 intensity reading	0/0/2		4 bytes	C	-	W	-	-	electric cu...	Low
135	[Balancing-EVSE1] Current limit	Amps	EVSE1 assigned limit	0/0/4	4 bytes	C	R	-	T	-	electric cu...	Low
137	[Balancing-EVSE1] Pause/Restart charging	Start / Stop	Pause/Resume EVSE1	0/0/6	1 bit	C	R	-	T	-	start/stop	Low
148	[Balancing-EVSE2] Instantaneous Single-phase Curr... Amps	EVSE2 intensity reading	0/0/3		4 bytes	C	-	W	-	-	electric cu...	Low
150	[Balancing-EVSE2] Current limit	Amps	EVSE2 assigned limit	0/0/5	4 bytes	C	R	-	T	-	electric cu...	Low
152	[Balancing-EVSE2] Pause/Restart charging	Start / Stop	Pause/Resume EVSE2	0/0/7	1 bit	C	R	-	T	-	start/stop	Low

To add more chargers to the system, simply replicate the group address structure used for the EVSE Slaves (current reading, current limit and charging control).

## Communication Objects

The communication objects of the chargers are summarized below:

No.	Name	Función	Descripción	Long.	Flags	DPT
1	[EVSE] Current limit	Total Amps	Input for the upper current limit of the charge point that can be supplied to the vehicle	4 bytes	C-W--	[14.019] electric current (A)
2	[EVSE] Active Power limit	Total Watts	Input for the upper active power limit of the charge point that can be supplied to the vehicle	4 bytes	C-W--	[14.056] power (W)
3	[EVSE] Current limit Status	Total Amps	Feedback of the upper current limit of the charge point that can be supplied to the vehicle	4 bytes	CR-T--	[14.019] electric current (A)
4	[EVSE] Active Power limit Status	Total Watts	Feedback of the upper active power limit of the charge point that can be supplied to the vehicle	4 bytes	CR-T-	[14.056] power (W)
5	[EVSE] Reset	Charger reset	Resets the charger	1 bit	C-W--	[1.015] reset
6	[EVSE] Maximum Charging session	Seconds	Sets the maximum charging session time in seconds	2 bytes	C-W--	[7.005] time (s)
7	[EVSE] Auto disconnect after charging session	1: auto, 0: no auto	If active (1), it will disconnect after the charging session	1 bit	C-W--	[1.003] enable
8	[EVSE] Add RFIDTag authorization	RFIDTag ID	Allows storing new RFID authorizations	14 bytes	C-W--	[16.001] Character String (ISO 8859-1)
9	[EVSE] Erase all authorized RFIDTags	1: delete all, 0: nothing	Erases all RFID tags stored in the system	1 bit	C-W--	[1.017] trigger
10	[EVSE] Fail-safe Status	1: active, 0: inactive	Feedback when the charging station has entered Fail-safe mode	1 bit	CR-T-	[1.002] boolean
11	[EVSE] Fail-safe Current	Amps	Feedback of the current used during Fail-safe mode in the station	4 bytes	CR-T-	[14.019] electric current (A)
12	[EVSE] Fail-safe Active Power Status	Watts	Feedback of the power used during Fail-safe mode in the station	4 bytes	CR-T-	[14.056] power (W)
13	[EVSE] Instantaneous Active Power	Watts	Instantaneous power of the charge point	4 bytes	CR-T-	[14.056] power (W)
14	[EVSE] Instantaneous Single-phase Current	Amps	Instantaneous single-phase current of the charge point	4 bytes	CR-T-	[14.019] electric current (A)
15	[EVSE] Instantaneous L1 Current	Amps	Instantaneous current of the charge point in phase L1	4 bytes	CR-T-	[14.019] electric current (A)
16	[EVSE] Instantaneous L2 Current	Amps	Instantaneous current of the charge point in phase L2	4 bytes	CR-T-	[14.019] electric current (A)
17	[EVSE] Instantaneous L3 Current	Amps	Instantaneous current of the charge point in phase L3	4 bytes	CR-T-	[14.019] electric current (A)
18	[EVSE] Pause / Restart any charging	Start / stop	Allows to pause/restart any charging	1 bit	C-W--	[1.010] start/stop
19	[EVSE] Error code	Error code	Error code of the charge point	1 byte	CR-T-	[20.1221] EVSEErrorCode
20	[EVSE] Communication error with EVSE	1: error, 0: no error	Shows 1 if failure and 0 if no error detected	1 bit	CR-T-	[1.005] alarm
25	[EVSE] Block	1: block, 0: unblock	Allows to lock (1) or unlock (0) the charger	1 bit	C-W--	[1.001] switch
26	[EVSE] Auto charging init after connect	1: block, 0: unblock	Allows to lock (1) or unlock (0) the charger	1 bit	C-W--	[1.003] enable
31	[Conn1] Current limit	Amps	Input for the upper current limit of the charge point that can be supplied to the vehicle through Connector 1	4 bytes	C-W--	[14.019] electric current (A)
32	[Conn1] Active Power limit	Watts	Input for the upper active power limit of the charge point that can be supplied to the vehicle through Connector 1	4 bytes	C-W--	[14.056] power (W)
33	[Conn1] Start - Stop charging	Start / Stop	Allows to start/stop the charge for the connector 1	1 bit	C-W--	[1.010] start/stop
34	[Conn1] Charger Status - Pilot State	Pilot state	Charge point status of Connector 1 according to the control pilot	1 byte	CR-T-	[20.1219] Control Pilot State
35	[Conn1] Charger Status - OCPP State	OCPP State	Charge point status of Connector 1 according to OCPP	1 byte	CR-T-	[20.1220] OCPP State
36	[Conn1] Vehicle connected	1: connected	Shows 1 if the vehicle is connected to the connector 1	1 bit	CR-T-	[1.002] boolean
37	[Conn1] Charging	1: charging	Shows 1 if the connector 1 is charging	1 bit	CR-T-	[1.011] state
38	[Conn1] Charger available	1: available charger	Shows 1 if the connector 1 is available	1 bit	CR-T-	[1.002] boolean
39	[Conn1] Charging suspended by EV	1: Charge suspended by EV	Shows 1 if the charge has been suspended by the EV for the connector 1	1 bit	CR-T-	[1.002] boolean
40	[Conn1] Charging suspended by EVSE	1: Chage suspended by EVSE	Shows 1 if the charge has been suspended by the EVSE for the connector 1	1 bit	CR-T-	[1.002] boolean

41	[Conn1] Charging finished	1: Finished	Shows 1 if the charging has finished for the connector 1	1 bit	CR-T-	[1.002] boolean
42	[Conn1] Charger reserved	1: Reserved	Shows 1 if charging is reserved on Connector 1	1 bit	CR-T-	[1.002] boolean
43	[Conn1] Charger unavailable	1: not available	Shows 1 if the charger is unavailable for connector 1	1 bit	CR-T-	[1.002] boolean
44	[Conn1] Charger fault	1: error	Shows 1 if the charger detects an error for the connector 1	1 bit	CR-T-	[1.002] boolean
45	[Conn1] Current session time	Seconds	Shows the charging time for the connector 1	2 bytes	CR-T-	[7.005] time (s)
46	[Conn1] Current session Energy	Wh	Shows the current sesión energy for the connector 1	4 bytes	CR-T-	[13.010] active energy (Wh)
47	[Conn1] Instantaneous Active Power	Watts	Shows the instantaneus active power for the connector 1	4 bytes	CR-T-	[14.056] power (W)
48	[Conn1] Instantaneous Single-phase Current	Amps	Shows the instantaneous single-phase current for the connector 1	4 bytes	CR-T-	[14.019] electric current (A)
49	[Conn1] Instantaneous L1 Current	Amps	Shows the instantaneous current for the pase L1 in the connector 1	4 bytes	CR-T-	[14.019] electric current (A)
50	[Conn1] Instantaneous L2 Current	Amps	Shows the instantaneous current for the pase L2 in the connector 1	4 bytes	CR-T-	[14.019] electric current (A)
51	[Conn1] Instantaneous L3 Current	Amps	Shows the instantaneous current for the pase L3 in the connector 1	4 bytes	CR-T-	[14.019] electric current (A)
54	[Conn1] Enable/Disable charging time 1	1: enable, 0: disable	Enables (1) or disables (0) the chrarging time 1 of the connector 1	1 bit	C-W--	[1.003] enable
57	[Conn1] Enable/Disable charging time 2	1: enable, 0: disable	Enables (1) or disables (0) the chrarging time 2 of the connector 1	1 bit	C-W--	[1.003] enable
60	[Conn1] Enable/Disable charging time 3	1: enable, 0: disable	Enables (1) or disables (0) the chrarging time 3 of the connector 1	1 bit	C-W--	[1.003] enable
61	[Conn1] Current limit Status	Amps	Shows the current limit status for the connector 1	4 bytes	CR-T-	[14.019] electric current (A)
62	[Conn1] Fail-safe Current Status	Amps	Shows the Fail-safe current status for the connector 1	4 bytes	CR-T-	[14.019] electric current (A)
63	[Conn1] Active Power limit Status	Watts	Shows the active power limit status for the connector 1	4 bytes	CR-T-	[14.056] power (W)
64	[Conn1] Fail-safe Active Power Status	Watts	Shows the Fail-safe active power status for the connector 1	4 bytes	CR-T-	[14.056] power (W)
65	[Conn1] Connector unlock	1: Shoot connector unlock	Allows to unlock the connector 1	1 bit	C-W--	[1.017] trigger
67	[Conn1] RFIDTag charging started	RFIDTag ID	Shows if the RFIDTag charging started with the connector 1	14 bytes	CR-T-	[16.001] Character String (ISO 8859-1)
73	[Conn1] Block	1: block, 0: unblock	Allows to block (1) or unblock (0) the connector 1	1 bit	C-W--	[1.001] switch
80	[Conn2] Current limit	Amps	Input for the upper current limit of the charge point that can be supplied to the vehicle through Connector 2	4 bytes	C-W--	[14.019] electric current (A)
81	[Conn2] Active Power limit	Watts	Input for the upper active power limit of the charge point that can be supplied to the vehicle through Connector 2	4 bytes	C-W--	[14.056] power (W)
82	[Conn2] Start - Stop charging	Start / Stop	Allows to start/stop the charge for the connector 2	1 bit	C-W--	[1.010] start/stop
83	[Conn2] Charger Status - Pilot State	Pilot State	Charge point status of Connector 2 according to the control pilot	1 byte	CR-T-	[20.1219] Control Pilot State
84	[Conn2] Charger Status - OCPP State	OCPP State	Charge point status of Connector 2 according to OCPP	1 byte	CR-T-	[20.1220] OCPP State
85	[Conn2] Vehicle connected	1: connected	Shows 1 if the vehicle is connected to the connector 2	1 bit	CR-T-	[1.002] boolean
86	[Conn2] Charging	1: charging	Shows 1 if the connector 2 is charging	1 bit	CR-T-	[1.011] state
87	[Conn2] Charger available	1: Available charger	Shows 1 if the connector 2 is available	1 bit	CR-T-	[1.002] boolean
88	[Conn2] Charging suspended by EV	1: Charge suspended by EV	Shows 1 if the charge has been suspended by the EV for the connector 2	1 bit	CR-T-	[1.002] boolean
89	[Conn2] Charging suspended by EVSE	1: Charge suspended byEVSE	Shows 1 if the charge has been suspended by the EVSE for the connector 2	1 bit	CR-T-	[1.002] boolean
90	[Conn2] Charging finished	1: Finished	Shows 1 if the charging has finished for the connector 2	1 bit	CR-T-	[1.002] boolean
91	[Conn2] Charger reserved	1: Reserves	Shows 1 if charging is reserved on Connector 2	1 bit	CR-T-	[1.002] boolean
92	[Conn2] Charger unavailable	1: unavailable	Shows 1 if the charger is unavailable for connector 2	1 bit	CR-T-	[1.002] boolean
93	[Conn2] Charger fault	1: error	Shows 1 if the charger detects an error for the connector 2	1 bit	CR-T-	[1.002] boolean
94	[Conn2] Current session time	Seconds	Shows the charging time for the connector 2	2 bytes	CR-T-	[7.005] time (s)
95	[Conn2] Current session Energy	Wh	Shows the current sesión energy for the connector 2	4 bytes	CR-T-	[13.010] active energy (Wh)
96	[Conn2] Instantaneous Active Power	Watts	Shows the instantaneus active power for the connector 2	4 bytes	CR-T-	[14.056] power (W)
97	[Conn2] Instantaneous Single-phase Current	Amps	Shows the instantaneous single-phase current for the connector 2	4 bytes	CR-T-	[14.019] electric current (A)
98	[Conn2] Instantaneous L1 Current	Amps	Shows the instantaneous current for the pase L1 in the connector 2	4 bytes	CR-T-	[14.019] electric current (A)
99	[Conn2] Instantaneous L2 Current	Amps	Shows the instantaneous current for the pase L2 in the connector 2	4 bytes	CR-T-	[14.019] electric current (A)

100	[Conn2] Instantaneous L3 Current	Amps	Shows the instantaneous current for the phase L3 in the connector 2	4 bytes	CR-T-	[14.019] electric current (A)
103	[Conn2] Enable/Disable charging time 1	1: enable, 0: disable	Enables (1) or disables (0) the charging time 1 of the connector 2	1 bit	C-W--	[1.003] enable
106	[Conn2] Enable/Disable charging time 2	1: enable, 0: disable	Enables (1) or disables (0) the charging time 2 of the connector 2	1 bit	C-W--	[1.003] enable
109	[Conn2] Enable/Disable charging time 3	1: enable, 0: disable	Enables (1) or disables (0) the charging time 3 of the connector 2	1 bit	C-W--	[1.003] enable
110	[Conn2] Current limit Status	Amps	Shows the current limit status for the connector 2	4 bytes	CR-T-	[14.019] electric current (A)
111	[Conn2] Fail-safe Current Status	Amps	Shows the Fail-safe current status for the connector 2	4 bytes	CR-T-	[14.019] electric current (A)
112	[Conn2] Active Power limit Status	Watts	Shows the active power limit status for the connector 2	4 bytes	CR-T-	[14.056] power (W)
113	[Conn2] Fail-safe Active Power Status	Watts	Shows the Fail-safe active power status for the connector 2	4 bytes	CR-T-	[14.056] power (W)
114	[Conn2] Connector unlock	1: Shoot connector unlock	Allows to unlock the connector 2	1 bit	C-W--	[1.017] trigger
116	[Conn2] RFIDTag charging started	RFIDTag	Shows whether charging with the RFIDTag has started on Connector 2	14 bytes	CR-T-	[16.001] Character String (ISO 8859-1)
122	[Conn2] Block	1: block, 0: unblock	Allows to block (1) or unblock (0) the connector 2	1 bit	C-W--	[1.001] switch
130	[Balancing] Current measured	A	Sets the measured current	4 bytes	C-W--	[14.019] electric current (A)
131	[Balancing] Active Power measured	W	Sets the measured active power	4 bytes	C-W--	[14.056] power (W)
132	[Balancing] Switch On/Off	1: On; 0: Off	Allows to switch on (1) or off (0) the balancing system	1 bit	C-W--	[1.001] switch
133	[Balancing-EVSE1] Instantaneous Single-phase Current	Amps	Sets the instantaneous single-phase current for the EVSE 1	4 bytes	C-W--	[14.019] electric current (A)
134	[Balancing-EVSE1] Instantaneous Active Power	Watts	Sets the instantaneous active power of the EVSE 1	4 bytes	C-W--	[14.056] power (W)
135	[Balancing-EVSE1] Current limit	Amps	Sets the current limit for the EVSE 1	4 bytes	C-W--	[14.019] electric current (A)
136	[Balancing-EVSE1] Active Power limit	Watts	Sets the active power limit for the EVSE 1	4 bytes	C-W--	[14.056] power (W)
137	[Balancing-EVSE1] Pause/Restart charging	Start / Stop	Allows to pause / start the charge with the EVSE 1	1 bit	CR-T-	[1.010] start/stop
148	[Balancing-EVSE2] Instantaneous Single-phase Current	Amps	Sets the instantaneous single-phase current for the EVSE 2	4 bytes	C-W--	[14.019] electric current (A)
149	[Balancing-EVSE2] Instantaneous Active Power	Watts	Sets the instantaneous active power of the EVSE 2	4 bytes	C-W--	[14.056] power (W)
150	[Balancing-EVSE2] Current limit	Amps	Sets the current limit for the EVSE 2	4 bytes	C-W--	[14.019] electric current (A)
151	[Balancing-EVSE2] Active Power limit	Watts	Sets the active power limit for the EVSE 2	4 bytes	C-W--	[14.056] power (W)
152	[Balancing-EVSE2] Pause/Restart charging	Start / Stop	Allows to pause / start the charge with the EVSE 2	1 bit	CR-T-	[1.010] start/stop
163	[Balancing-EVSE3] Instantaneous Single-phase Current	Amps	Sets the instantaneous single-phase current for the EVSE 3	4 bytes	C-W--	[14.019] electric current (A)
164	[Balancing-EVSE3] Instantaneous Active Power	Watts	Sets the instantaneous active power of the EVSE 3	4 bytes	C-W--	[14.056] power (W)
165	[Balancing-EVSE3] Current limit	Amps	Sets the current limit for the EVSE 3	4 bytes	C-W--	[14.019] electric current (A)
166	[Balancing-EVSE3] Active Power limit	Watts	Sets the active power limit for the EVSE 3	4 bytes	C-W--	[14.056] power (W)
167	[Balancing-EVSE3] Pause/Restart charging	Start / Stop	Allows to pause / start the charge with the EVSE 3	1 bit	CR-T-	[1.010] start/stop
178	[Balancing-EVSE4] Instantaneous Single-phase Current	Amps	Sets the instantaneous single-phase current for the EVSE 4	4 bytes	C-W--	[14.019] electric current (A)
179	[Balancing-EVSE4] Instantaneous Active Power	Watts	Sets the instantaneous active power of the EVSE 4	4 bytes	C-W--	[14.056] power (W)
180	[Balancing-EVSE4] Current limit	Amps	Sets the current limit for the EVSE 4	4 bytes	C-W--	[14.019] electric current (A)
181	[Balancing-EVSE4] Active Power limit	Watts	Sets the active power limit for the EVSE 4	4 bytes	C-W--	[14.056] power (W)
182	[Balancing-EVSE4] Pause/Restart charging	Start / Stop	Allows to pause / start the charge with the EVSE 4	1 bit	CR-T-	[1.010] start/stop
193	[Balancing-EVSE5] Instantaneous Single-phase Current	Amps	Sets the instantaneous single-phase current for the EVSE 5	4 bytes	C-W--	[14.019] electric current (A)
194	[Balancing-EVSE5] Instantaneous Active Power	Watts	Sets the instantaneous active power of the EVSE 5	4 bytes	C-W--	[14.056] power (W)
195	[Balancing-EVSE5] Current limit	Amps	Sets the current limit for the EVSE 5	4 bytes	C-W--	[14.019] electric current (A)
196	[Balancing-EVSE5] Active Power limit	Watts	Sets the active power limit for the EVSE 5	4 bytes	C-W--	[14.056] power (W)
197	[Balancing-EVSE5] Pause/Restart charging	Start / Stop	Allows to pause / start the charge with the EVSE 5	1 bit	CR-T-	[1.010] start/stop

208	[Balancing-EVSE6] Instantaneous Single-phase Current	Amps	Sets the instantaneous single-phase current for the EVSE 6	4 bytes	C-W--	[14.019] electric current (A)
209	[Balancing-EVSE6] Instantaneous Active Power	Watts	Sets the instantaneous active power of the EVSE 6	4 bytes	C-W--	[14.056] power (W)
210	[Balancing-EVSE6] Current limit	Amps	Sets the current limit for the EVSE 6	4 bytes	C-W--	[14.019] electric current (A)
211	[Balancing-EVSE6] Active Power limit	Watts	Sets the active power limit for the EVSE 6	4 bytes	C-W--	[14.056] power (W)
212	[Balancing-EVSE6] Pause/Restart charging	Start / Stop	Allows to pause / start the charge with the EVSE 6	1 bit	CR-T-	[1.010] start/stop