

Installation Guide



WHERE ARE WE

Calle Dinámica N°1, Pol. Ind. Santa Rita
08755 Castellbisbal, Barcelona SPAIN



CALL US

Ph +34 918 315 425
Fax +34 937 720 018



DOWNLOAD



faro@lorefar.com
www.faro.es



FOLLOW US



CONGRATULATIONS

> **ESPAÑOL** Felicidades por la compra de su nuevo ventilador Faro Barcelona que le proporcionará, diseño, calidad y confort durante muchos años. Estamos orgullosos de nuestro trabajo y apreciamos la oportunidad de suministrarle uno de los mejores ventiladores de techo disponibles. ¡Toca empezar a disfrutar de su ventilador de techo Faro Barcelona!

> **CATALÀ** Felicitats per la compra del seu nou ventilador Faro Barcelona que li proporcionarà, disseny, qualitat i confort durant molts anys. Estem orgullosos del nostre treball i apreciem l'oportunitat de subministrar-li un dels millors ventiladors de sostre disponibles. Comenci a gaudir del seu ventilador de sostre Faro Barcelona!

> **ENGLISH** Congratulations on the purchase of your new Faro Barcelona fan that will provide you, design, quality and comfort for many years. We are proud of our work and appreciate the opportunity to provide one of the best ceiling fans available. It's time to start enjoying your Faro Barcelona ceiling fan!

> **FRANÇAIS** Félicitations pour l'achat de votre nouveau ventilateur Faro Barcelona qui vous apportera design, qualité et confort pendant de nombreuses années. Nous sommes fiers de notre travail et apprécions l'opportunité de fournir l'un

des meilleurs ventilateurs de plafond disponibles. Il est temps de commencer à profiter de votre ventilateur de plafond Faro Barcelona!

> **ITALIANO** Congratulazioni per aver acquistato un ventilatore Faro Barcelona che le garantirà design, qualità e comfort per molto tempo. Siamo orgogliosi del nostro lavoro e apprezziamo molto che ci abbia dato l'opportunità di fornirle uno dei migliori ventilatori da soffitto disponibili nel mercato. Cominci ad utilizzare il suo nuovo ventilatore da soffitto Faro Barcelona!

> **PORTUGÊS** Parabéns pela compra do seu novo ventilador de Faro Barcelona que lhe proporcionará design, qualidade e conforto por muitos anos. Estamos orgulhosos do nosso trabalho e apreciamos a oportunidade de fornecer um dos melhores ventiladores de teto disponíveis. É hora de começar a desfrutar do seu ventilador de teto Faro Barcelona!

> **DEUTSCH** Herzlichen Glückwunsch zum Kauf Ihres neuen Faro Barcelona Ventilators, der Ihnen Design, Qualität und Komfort für viele Jahre bieten wird. Wir sind stolz auf unsere Arbeit und schätzen die Möglichkeit, Ihnen einen der besten Deckenventilatoren zu liefern. Es ist an der Zeit, Ihren Faro Barcelona Deckenventilator zu genießen!

> **NEDERLANDS** Gefeliciteerd met de aankoop van uw nieuwe Faro Barcelona ventilator. Deze zal u kwaliteit en con-

fort bieden voor vele jaren. Wij zijn trots op ons werk, en waarderen de mogelijkheid om u een van de beste beschikbare plafondventilatoren te leveren. Geniet van uw nieuwe Faro Barcelona plafondventilator!

> **ΕΛΛΗΝΙΚΗ** Συγχαρητήρια για την αγορά του νέου σας ανεμιστήρα Faro Barcelona που θα σας προσφέρει ντιζάιν, ποιότητα και άνεση για πολλά χρόνια. Είμαστε υπερήφανοι για την δουλειά μας και εκτιμούμε την ευκαιρία να σας προσφέρουμε έναν από τους καλύτερους ανεμιστήρες οροφής της αγοράς. Ήρθε η ώρα να απολαύσετε τον ανεμιστήρα οροφής Faro Barcelona!

> **РУССКИЙ** Поздравляем вас с приобретением вентилятора Faro Barcelona нового поколения, который будет радовать вас своим дизайном, качеством и комфортом в течение многих лет. Мы гордимся нашей работой и ценим возможность предоставить вам один из лучших потолочных вентиляторов. Пришло время начать наслаждаться потолочным вентилятором Faro Barcelona! > **ČESKY** Gratulujeme vám k zakoupení vašeho nového ventilátoru Faro Barcelona, který vám poskytne design, kvalitu a komfort po mnoho let. Jsme hrdí na naši práci a vážíme si příležitosti poskytnout vám jeden z nejlepších stropních ventilátorů na trhu. Je načase začít si užívat váš stropní ventilátor Faro Barcelona!

> **POLSKI** Gratulujemy zakupu nowego wentylatora Faro Barcelona, który zapewni Ci design, jakość i komfort przez wiele lat. Jesteśmy dumni z naszej pracy i doceniamy możliwość zaferowania jednego z najlepszych dostępnych wentylatorów sufitowych. Czas zacząć cieszyć się swoim wentylatorem Faro Barcelona!

> **БЪЛГАРСКИ** Поздравления за закупуването на новия вентилатор от Faro Barcelona, който ще ви осигури дизайн, качество и удобство в продължение на много години. Гордеем се с нашата продукция и оценяваме възможността да ви предоставим един от най-добрите таванни вентилатори. Време е да започнете да се наслаждавате на таванния вентилатор на Faro Barcelona!

>> **SLOVENČINA** Blahoželáme k nákupu vašo nového ventilátora Faro Barcelona, ktorý vám poskytne dizajn, kvalitu a komfort po mnoho rokov. Sme hrdí na našu prácu a oceňujeme príležitosť poskytnúť jeden z najlepších stropných ventilátorov. Je čas začať si užívať váš stropný ventilátor Faro Barcelona!

<< العربية
تهانينا على شراء مروحة فارو برشلونة الجديدة التي ستوفر لك التصميم والجودة والراحة لسنوات عديدة. نحن فخورون بعملنا ونقدر الفرصة لتزويدك بأحد أفضل مراوح السقف المتاحة. لقد حان الوقت لبدء الاستمتاع بمروحة السقف فارو برشلونة.



**Together
we take care
of the planet**

Together we take care of the planet.

This is why we reduce paper consumption. Please refer to the safety, maintenance and warranty instructions at www.faro.es. If you cannot access it, call us at +34 937 723 965 or write to export@faro.es.

Juntos cuidamos el planeta. Por eso reducimos el consumo de papel. Puedes consultar las instrucciones de seguridad, mantenimiento y garantía en www.faro.es. Si no puedes acceder, llámanos al +34 902 165 166 o escríbenos a faro@lorefar.com.

Junts cuidem el planeta. Per això reduïm el consum de paper. Pots consultar les instruccions de seguretat, manteniment i garantia en www.faro.es. Si no hi pots accedir, telefona'ns al +34 902 165 166 o escriu-nos a faro@lorefar.com.

Ensemble, nous prenons soin de la planète. C'est pourquoi nous réduisons la consommation de papier. Veuillez-vous référer aux instructions de sécurité, d'entretien et de garantie sur www.faro.es. Si vous ne pouvez pas y accéder, appelez-nous au +34 937 723 965 ou écrivez à export@faro.es.

Insieme proteggiamo il pianeta. Questo è il motivo per il quale abbiamo ridotto il consumo di carta. Per favore, leggi le istruzioni sulla sicurezza, la manutenzione e la garanzia sul sito www.faro.es.

Se non puoi accedere, chiamaci al +34 937 723 965 o scrivici a export@faro.es.

Juntos cuidamos do planeta. É por este motivo que reduzimos o consumo de papel. Consulte as instruções de segurança, manutenção e garantia em www.faro.es. Se não conseguir aceder, ligue para +34 937 723 965 ou escreva para export@faro.es.

Gemeinsam sorgen wir uns um unseren Planeten. Deshalb reduzieren wir den Papierverbrauch. Bitte beachten Sie die Sicherheits-, Wartungs- und Garantiehinweise unter www.faro.es. Wenn Sie nicht darauf zugreifen können, rufen Sie uns unter +34 937 723 965 an oder schreiben Sie an export@faro.es.

We dragen samen zorg voor onze planeet. Daarom verminderen wij het papiergebruik. Raadpleeg de veiligheids-, onderhouds- en garantiehandleiding op www.faro.es. Kan u ze niet raadplegen? Bel ons op +34 937 723 965 of schrijf ons op export@faro.es.

Μαζί φροντίζουμε τον πλανήτη. Για αυτόν τον λόγο μειώνουμε την κατανάλωση χαρτί. Παρακαλούμε, ανατρέξτε στις οδηγίες ασφαλείας, συντήρησης και εγγύησης στην ιστοσελίδα www.faro.es. Αν δεν μπορείτε να αποκτήσετε πρόσβαση, τηλεφωνήστε μας στο +34 937 723 965 ή γράψτε μας στο export@faro.es.

Вместе мы заботимся о планете. Вот почему мы сокращаем потребление бумаги. Пожалуйста, обратитесь к инструкциям по безопасности, техническому обслуживанию и гарантии на сайте www.faro.es. Если вы не можете получить к нему доступ, позвоните нам по телефону +34 937 723 965 или напишите на export@faro.es.

Společně pečujeme o planetu. Proto omezujeme spotřebu papíru. Přečtěte si, prosím, pokyny týkající se bezpečnosti, údržby a záruky na www.faro.es. Pokud na stránku nemáte přístup, zavolejte nám na tel. +34 937 723 965 nebo napište na export@faro.es.

Razem dbamy o planetę. Dlatego zmniejszamy zużycie papieru. Proszę zapoznać się z instrukcjami bezpieczeństwa, konserwacji i gwarancji na www.faro.es. Jeśli nie możesz uzyskać do niego dostępu, zadzwoń do nas pod numer +34 937 723 965 lub napisz na adres export@faro.es.

Заедно ние се грижим за планетата. Ето защо намаляваме консумацията на хартия. Моля, направете справка с инструкциите за безопасност, поддръжка и гаранция на www.faro.es. Ако нямате достъп до сайта, обадете ни се на +34 937 723 965 или пишете на export@faro.es.

Spoločne sme sa postarali o tejto planéte. To je dôvod, prečo sme znížili spotrebu papiera. Pozri pokyny k bezpečnosti, údržby a záruky na www.faro.es. Ak nemôžete pristupovať, zavolajte na telefónne číslo +34 937 723 965 alebo píšete n export@faro.es.

معاً نعتني بالكوكب.

هذا هو السبب في تقليل استهلاك الورق.

يرجى الرجوع إلى تعليمات السلامة

والصيانة والضمان على www.faro.es

إذا لم تتمكن من الولوج إليه، اتصل بنا

على +34 937 723 965 أو اكتب رسالة

إلى export@faro.es



> **ESPAÑOL:** El manual de contiene las instrucciones completas para instalar y operar con su ventilador de forma segura.

Recuerde apretar firmemente todos los tornillos y hacer todas las conexiones correctamente.

> **CATALÀ:** Els manuals contenen les instruccions completes per instal·lar i operar amb el seu ventilador de forma segura.

Recordi estrènyer fermament tots els cargols i fer totes les connexions correctament.

> **ENGLISH:** The manuals contain the complete instructions for installing and operating with your fan safely. Remember to tighten all screws firmly and make all connections correctly

> **FRANÇAIS:** Le manuel d'utilisation contient les instructions complètes pour installer et utiliser votre ventilateur en toute sécurité. N'oubliez pas de serrer toutes les vis fermement et de faire toutes les connexions correctement

> **ITALIANO:** Il manuale operativo contiene le istruzioni complete per installare ed utilizzare il suo ventilatore in totale sicurezza. Ricordi di avvitare bene tutti i bulloni e realizzare tutte le connessioni nella maniera corretta.

> **PORTUGÊS:** O manual de operação contém as instruções completas para instalação e operação com o seu ventilador com segurança. Lembre-se de apertar firmemente todos os parafusos e fazer todas as conexões corretamente.

> **DEUTSCH:** Die Betriebsanleitung enthält vollständige Anweisungen für die sichere Installation und den sicheren Betrieb Ihres Ventilators. Denken Sie daran, alle Schrauben fest anzuziehen und alle Verbindungen korrekt herzustellen.

> **NEDERLANDS:** De gebruikshandleiding bevat de volledige instructies voor de installatie en de veilige bediening van uw ventilator. Vergeet niet om alle schroeven stevig vast te draaien, en alle verbinding correct aan te sluiten.

> **ΕΛΛΗΝΙΚΗ:** Το εγχειρίδιο λειτουργίας περιέχει τις πλήρεις οδηγίες για την εγκατάσταση και λειτουργία με τον ανεμιστήρα σας με ασφάλεια. Θυμηθείτε να σφίξετε καλά όλες τις βίδες και να κάνετε σωστά όλη τη συνδεσμολογία.

> **РУССКИЙ:** Руководство по эксплуатации содержит полные инструкции по установке и безопасному использованию вашего вентилятора. Не забудьте крепко затянуть все винты и правильно установить все соединения.

> **ČESKY:** Provozní příručka obsahuje kompletní pokyny pro instalaci a bezpečný provoz vašeho ventilátoru. Nezapomeňte pevně dotáhnout všechny šrouby a vše správně připojit!

> **POLSKI:** Instrukcja obsługi zawiera kompletnie wskazówki dotyczące bezpiecznego instalowania i obsługi wentylatora. Pamiętaj, aby mocno dokręcić wszystkie śruby i prawidłowo wykonać wszystkie połączenia!

> **БЪЛГАРСКИ:** Ръководството за експлоатация съдържа пълните инструкции за безопасно монтиране и работа с вашия вентилатор. Не забравяйте да затегнете здраво всички винтове и да свържете правилно всички връзки.

> **SLOVENČINA:** Návod na obsluhu obsahuje úplné pokyny na inštaláciu a bezpečnú prevádzku s ventilátorom. Nezabudnite pevne utiahnuť všetky skrutky a urobiť všetky pripojenia správne.

<< العربية
يحتوي الدليل على التعليمات الكاملة لتثبيت
المروحة وتشغيلها بأمان. تذكر أن تشد بقوة
جميع البراغي والقيام بجميع التوصيلات بشكل
صحيح.

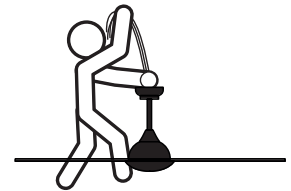
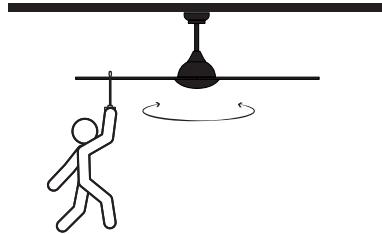
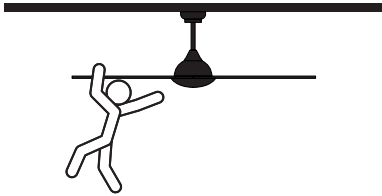
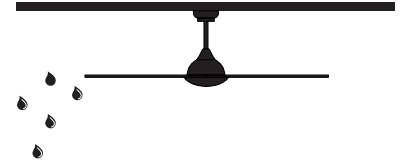
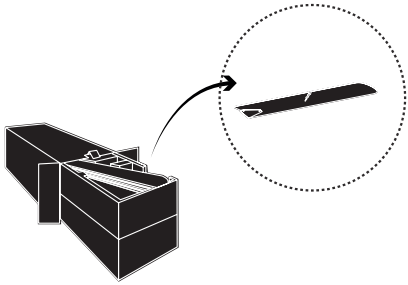

technical specifications

speeds	A	W	RPM	CFM	m³min
I - low		5	60		
II		8	80		
III		12	95		
IV		17	110		
V		25	125		
VI- High		35	140	8243	2334l

power	
V	220-240
Hz	50/60

sizes mm / inch

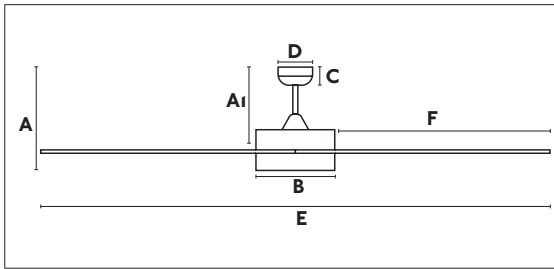

A	A1	B	C
324.9/12.8"	272.4/10.7"	209/8.22"	55/2.16"
D	E	F	
ø139.7/5.5"	ø1639/64.4"	714/28.11"	

weight

kg	11.1
lb	24.47



SMD LED 15W 3000K 400lm ~ 1200lm



Century

motor

material

Steel

finished

[33553](#) - White

[33554](#) - Matt Nickel

blades

material

PLY Wood

finished

[33553](#) - White

[33554](#) - Grey

light kit

material

Steel + PMMA

finished

Opal



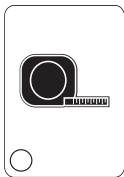
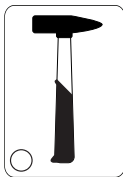
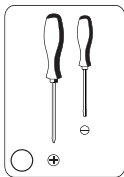
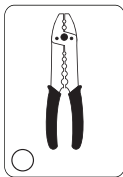
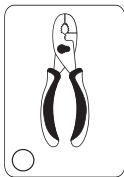

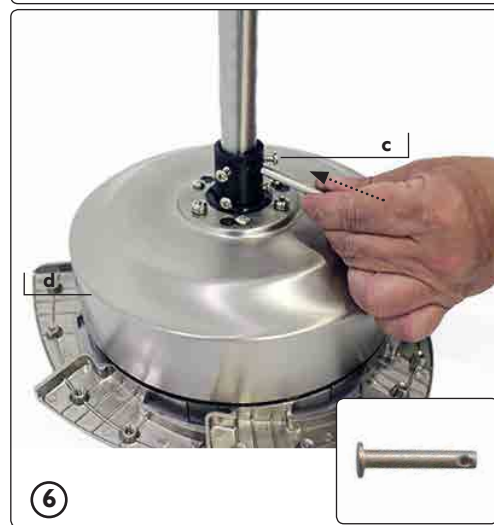
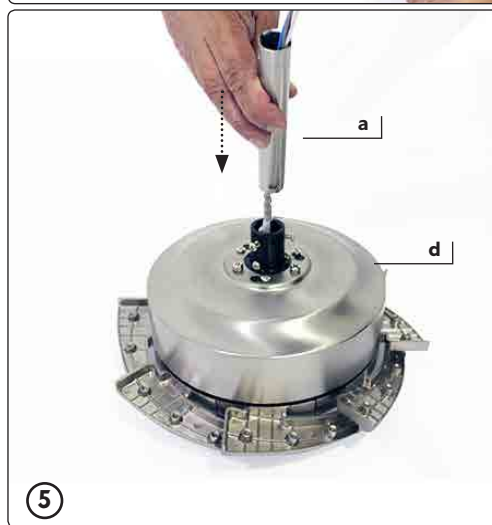
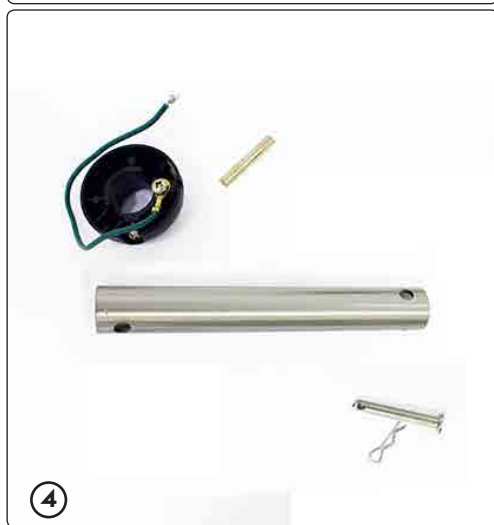
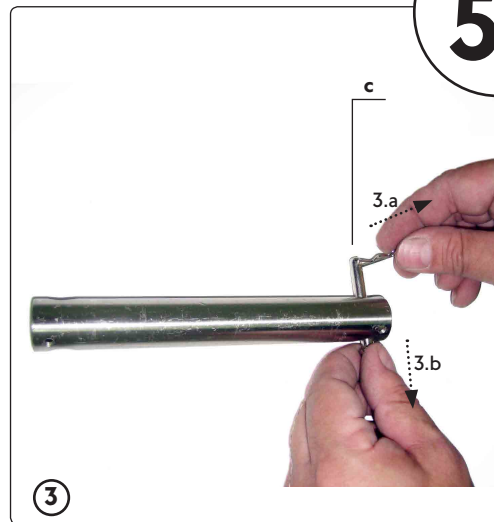
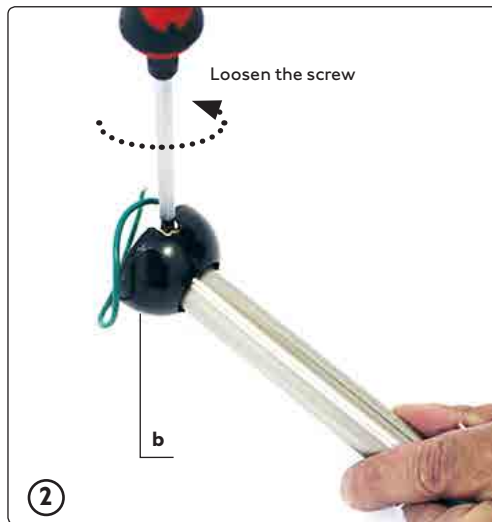
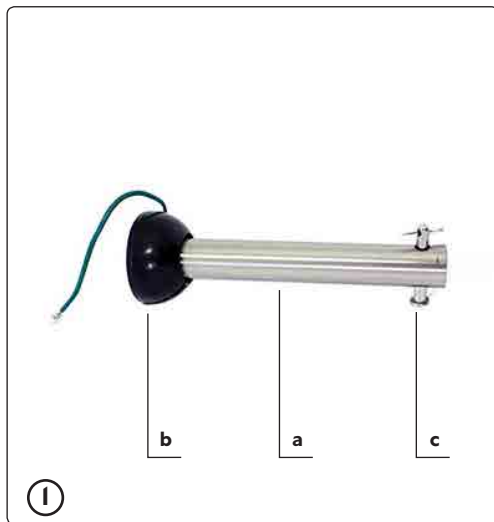

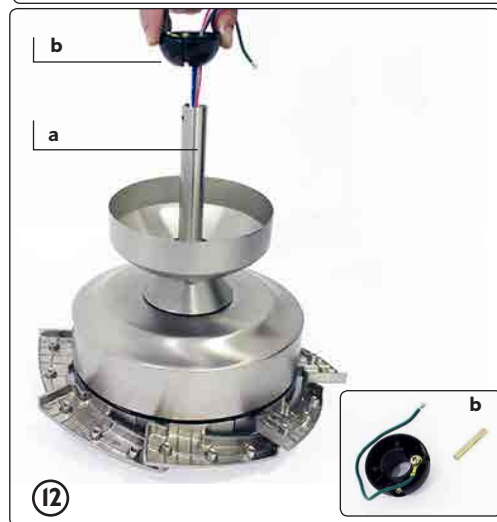
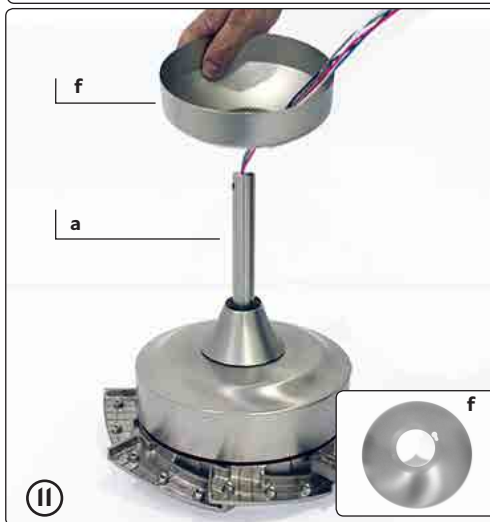
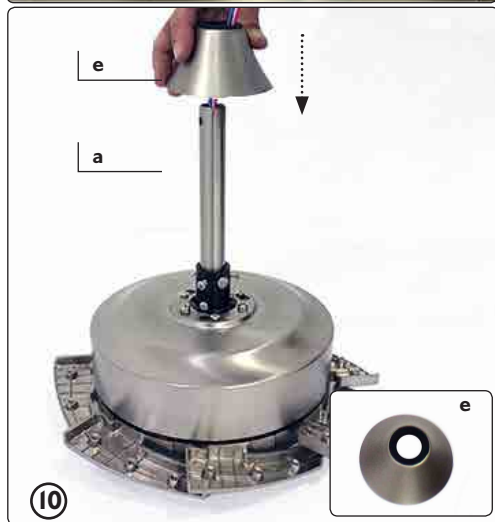
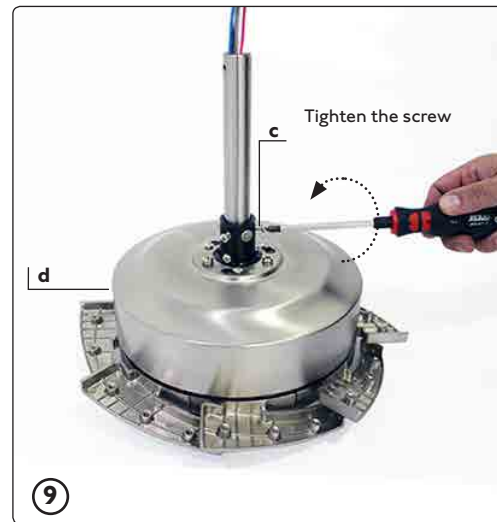
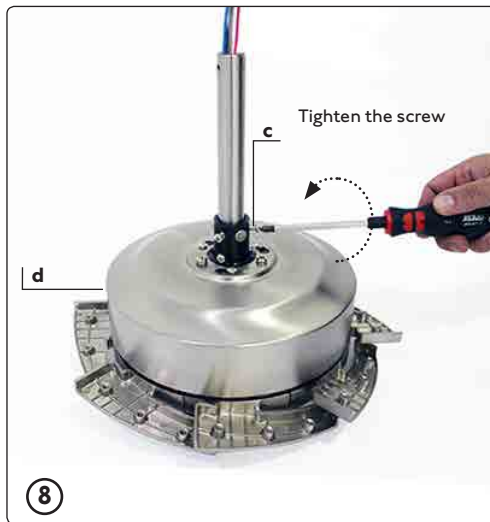

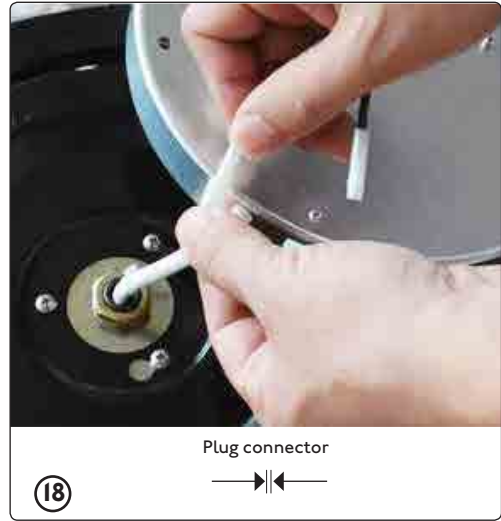
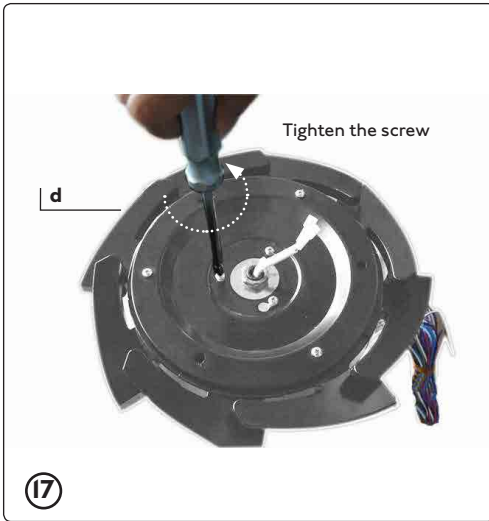
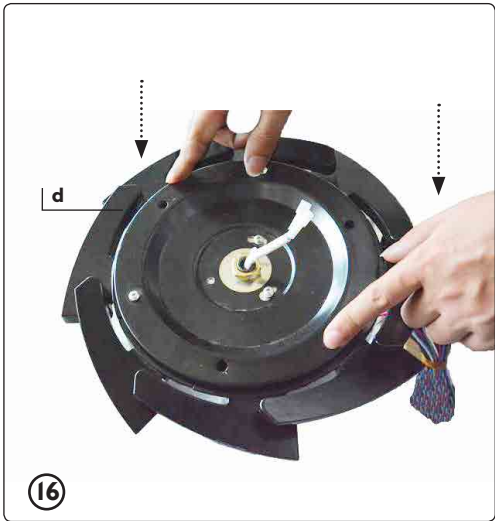
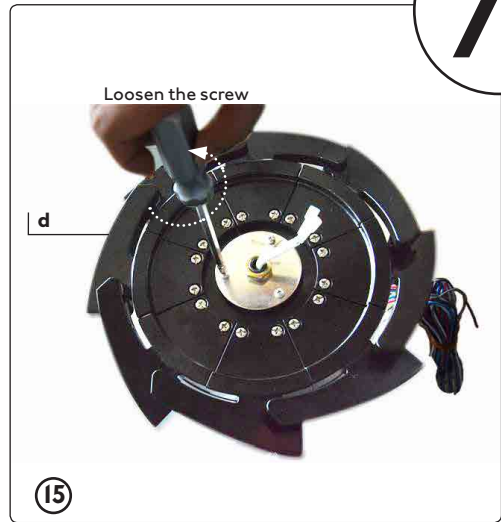
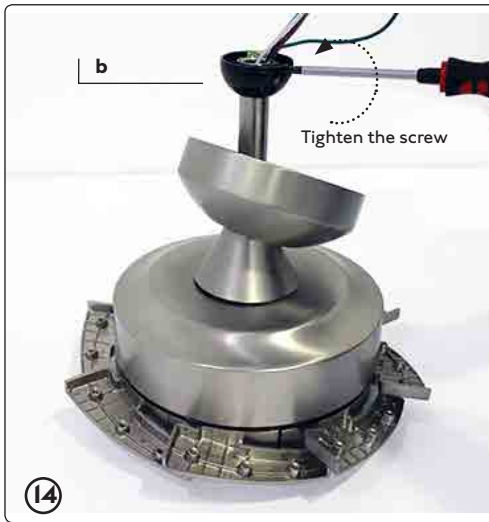
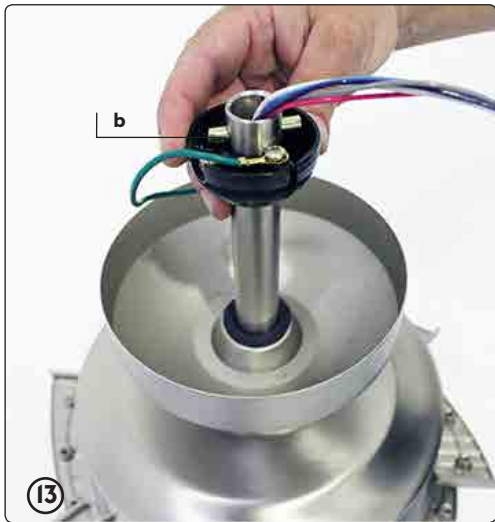

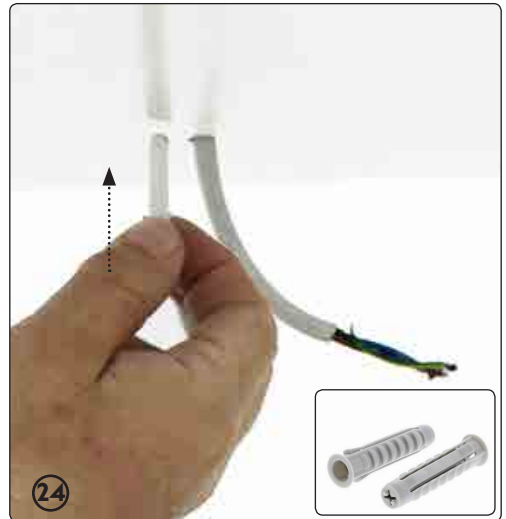
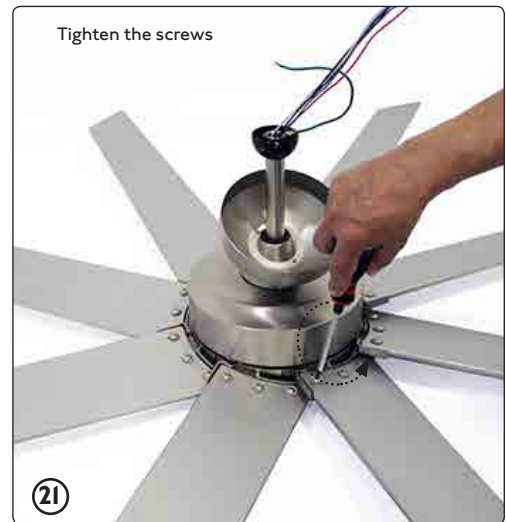
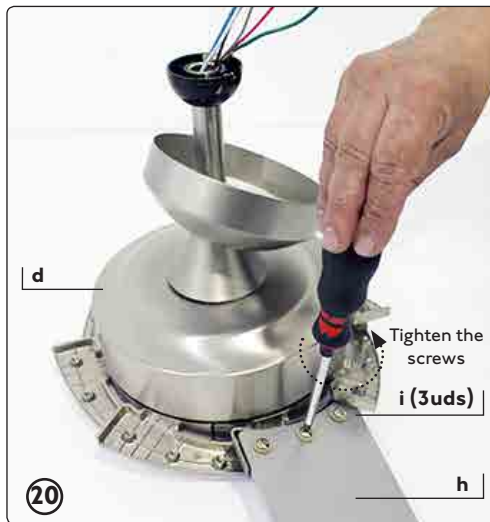
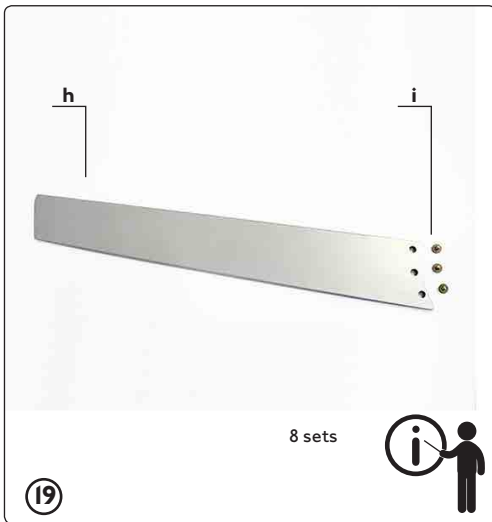

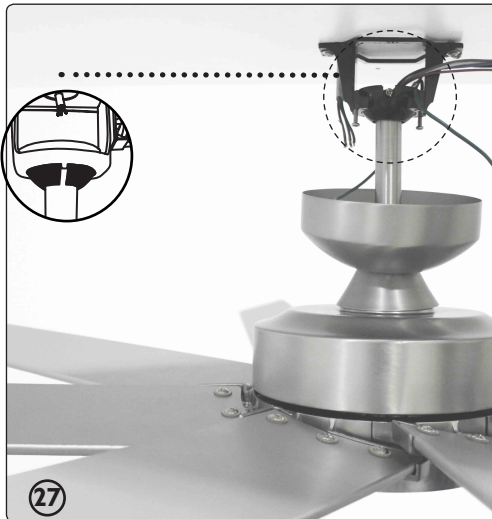

faqs - www.faro.es

L
marrón, marró,
brown, marron,
marrone, castanho,
braun, bruin, καφέ,
коричневый, hnědá,
brązowy, кафяв,
hnedý

بني

N
azul, blau, blue,
bleu, blu, azul, blau,
blauw, μπλε, синий,
modrá, niebieski,
син, modrý

أزرق

⊕
amarillo-verde, groc-
verd, yellow-green,
jaune-vert,
giallo-verde,
verde-amarelo, gelb-
grün, gell-groen,
κίτρινο-πράσινο,
желто-зеленый, žlu-
tozelená, żółto-zie-
lony, жълто-зелен,
žltozelená

أصفر - أخضر

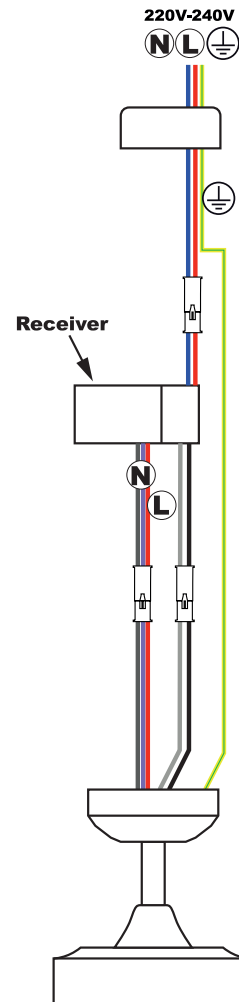

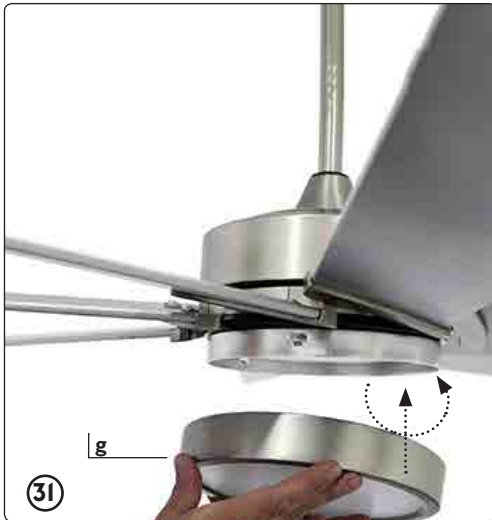
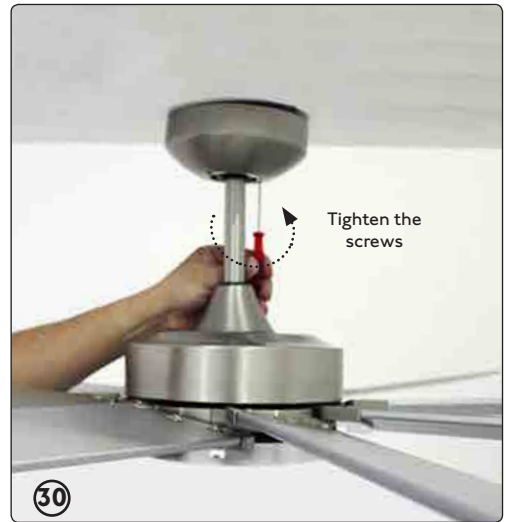
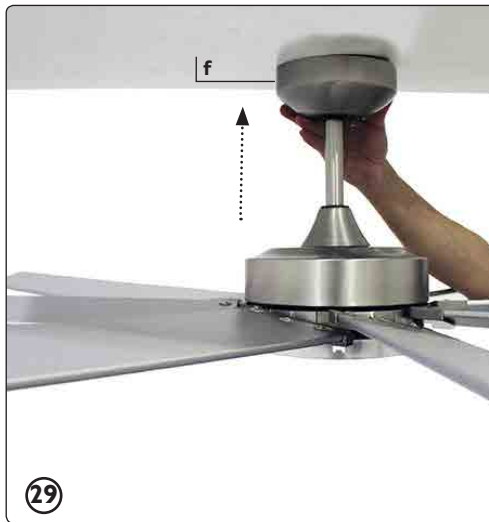

Remote control

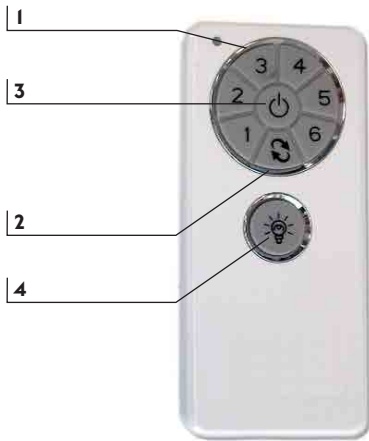

**LIGHT DIMMER
OPTION**
move to
"ON" or "OFF"



ESPAÑOL

- 1- Velocidades (1, 2, 3, 4, 5, 6)
- 2- Función inversa
- 3- Encendido y apagado del ventilador
- 4- Encendido y apagado del kit de luz

CATALÀ

- 1- Velocitats (1, 2, 3, 4, 5, 6)
- 2- Funció inversa
- 3- Encen i apaga el ventilador
- 4- Encen i apaga el kit de llum

ENGLISH

- 1- Fan speeds (1, 2, 3, 4, 5, 6)
- 2- Reverse function
- 3- On off for fan
- 4- Light on-off function

FRANÇAIS

- 1- Vitesses (1, 2, 3, 4, 5, 6)
- 2- Interrupteur a sens inverse pour changer la direction du tour du ventilateur
- 3- On/off ventilateur
- 4- Fonction marche / arrêt de la lumière

ITALIANO

- 1- Velocità (1, 2, 3, 4, 5, 6)
- 2- Senso di rotazione del ventilatore, in avanti o indietro.
- 3- On/off ventola
- 4- Funzione di accensione / spegnimento la luce

PORTUGÊS

- 1- Velocidades da ventoinha (1, 2, 3, 4, 5, 6)
- 2- Controla a direcção de rotação, para a frente ou para trás
- 3- Começando marcha e desemprego do ventonhia
- 4- Acenda e apague a luz

NEDERLANDS

- 1- Snelheden van de ventilator (1, 2, 3, 4, 5, 6)
- 2- Inverse functie
- 3- On/liche/off Verlichting
- 4- Schakelaar licht kit

DEUTSCH

- 1- ventilator snelheden (1, 2, 3, 4, 5, 6)
- 2- Umkehrfunktion
- 3- On/off ventilator
- 4- Lichtschalter

ΕΛΛΗΝΙΚΗ

- 1- Ταχύτητες (1, 2, 3, 4, 5, 6)
- 2- Αντίστροφη συνάρτηση
- 3- Εντός και εκτός του ανεμιστήρα
- 4- Διακόπτης φωτισμού kit

РУССКИЙ

- 1- Скорость потолочного вентилятора
- 2- Положение переключателя скоростей на период жаркой или холодной погоды
- 3- Позиция выключения вентилятора
- 4- Переключатель легкий комплект

ČESKY

- 1- Otáčky ventilátoru (1, 2, 3, 4, 5, 6)
- 2- Inverzní funkce
- 3- Zapněte a vypněte stropní ventilátor
- 4- Zapněte a vypněte světlo

POLSKI

- 1- Prędkości (1, 2, 3, 4, 5, 6)
- 2- Punkcja odwrotna
- 3- Włącz i wyłącz wentylator sufitowy
- 4- Włącz i wyłącz światło

БЪЛГАРСКИ

- 1- Скорости (1, 2, 3, 4, 5, 6)
- 2- Обратна функция
- 3- включете и изключете вентилатора на тавана
- 4- включете и изключете светлината

SLOVENČINA

- 1- Rýchlost
- 2- Inverznej funkcije
- 3- zapnite a vypnite svetlo
- 4- zapnite a vypnite stropný ventilátor

<< العربية

- 1- سرعات المروحة
- 2- وظيفة عكسية
- 3- لإطفاء المروحة. لتشغيل المروحة
- 4- الضوء



More than one pre-sync remote control & ceiling fan

Remote + Ceiling fan
n°1



①



OFF!!



②

Remote + Ceiling fan
n°2



2 x AAA 1.5V

③



ON!!



④

Remote + Ceiling fan
n°2



PUSH
"LEARN"

⑤

Remote + Ceiling fan
n°2

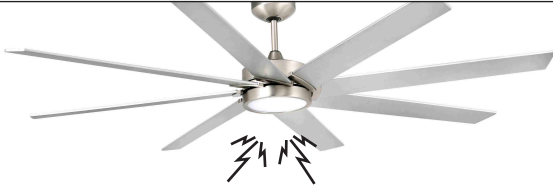

LIGHT FLASHER



PUSH
"LEARN SWITCH"

6-60"

6



7



8

SMART FAN

Note: Choose your remote control in the list below to pair it with the ceiling fan receiver.

Nota: Localice su mando a distancia para vincularlo con el receptor de su ventilador.

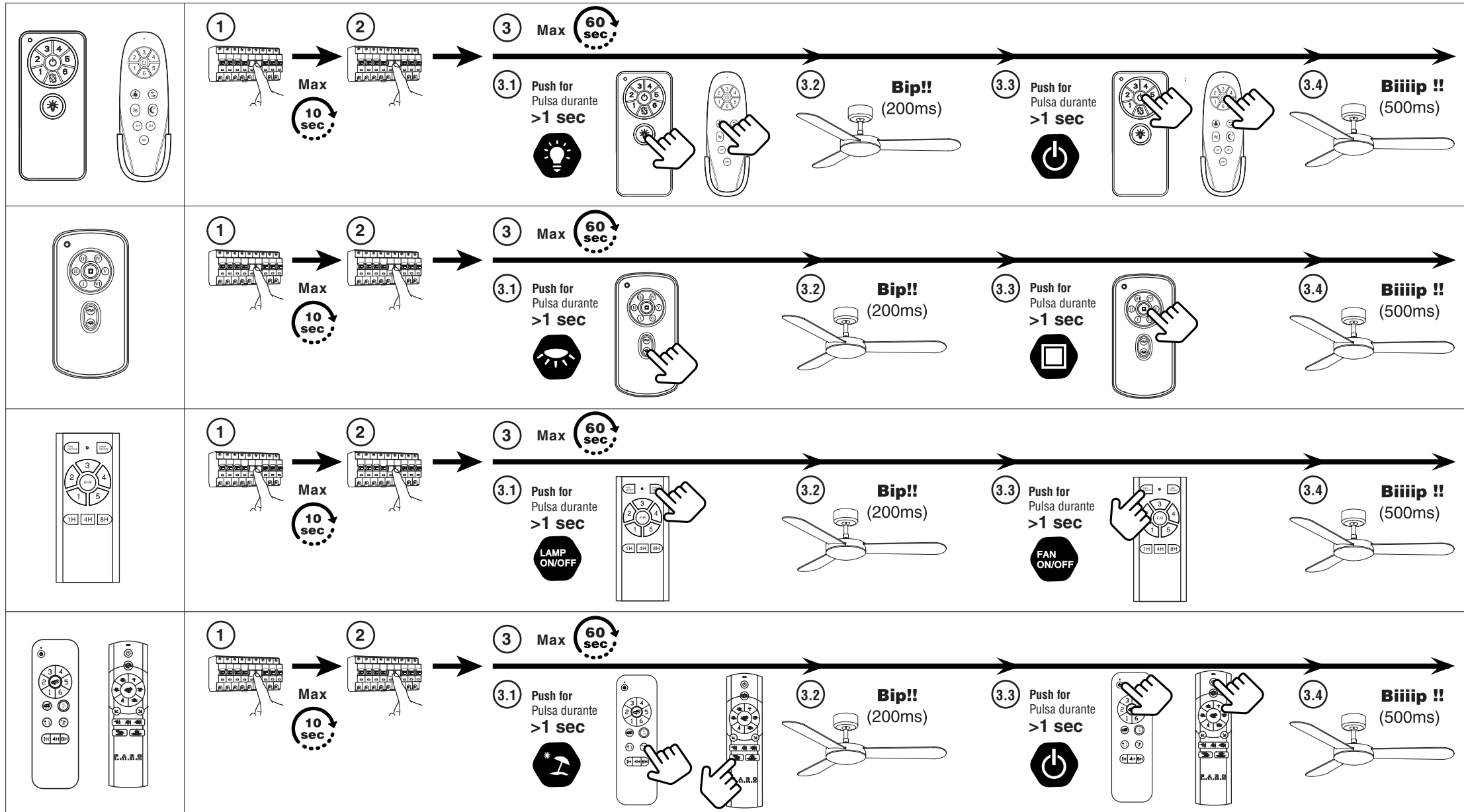

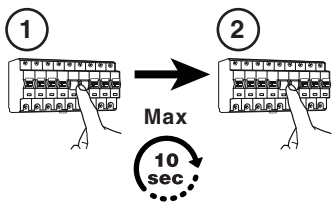
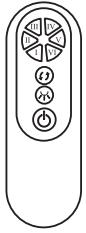

3 Max 60 sec

3.1 Push for Pulsa durante >1 sec

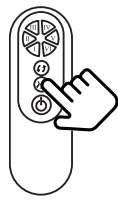

3.2 **Bip!!** (200ms)

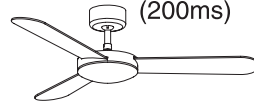

3.3 Push for Pulsa durante >1 sec

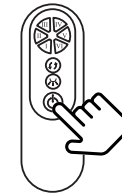

3.4 **Biiiiip !!** (500ms)

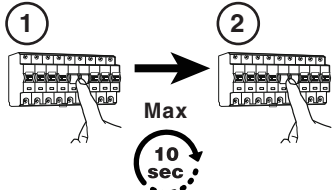
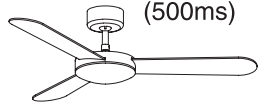

3 Max 60 sec

3.1 Push for Pulsa durante >1 sec

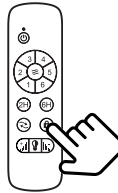

3.2 **Bip!!** (200ms)

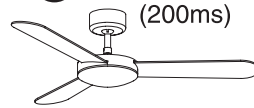

3.3 Push for Pulsa durante >1 sec

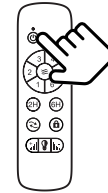

3.4 **Biiiiip !!** (500ms)

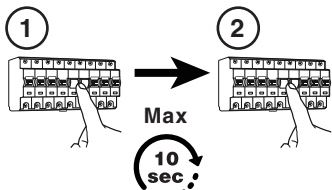
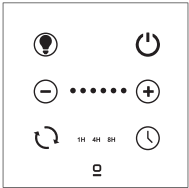
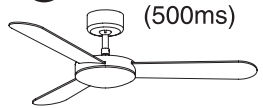

3 Max 60 sec

3.1 Push for Pulsa durante >1 sec

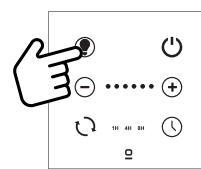

3.2 **Bip!!** (200ms)

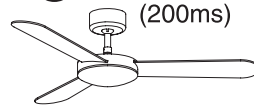

3.3 Push for Pulsa durante >1 sec

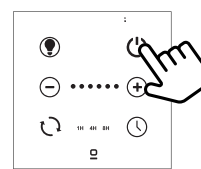

3.4 **Biiiiip !!** (500ms)

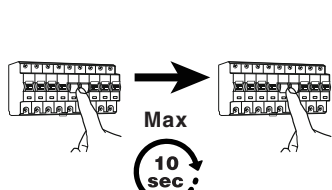
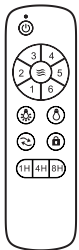
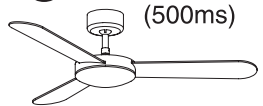

3 Max 60 sec

3.1 Push for Pulsa durante >1 sec

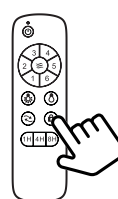

3.2 **Bip!!** (200ms)

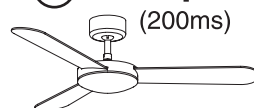

3.3 Push for Pulsa durante >1 sec



3.4 **Biiiiip !!** (500ms)

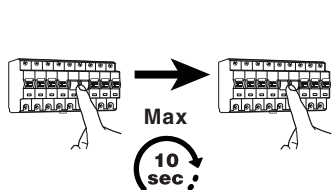
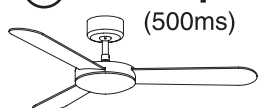

3 Max 60 sec

3.1 Push for Pulsa durante >1 sec

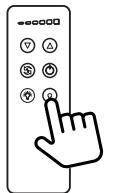

3.2 **Bip!!** (200ms)

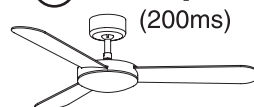

3.3 Push for Pulsa durante >1 sec

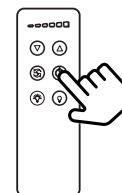

3.4 **Biiiiip !!** (500ms)

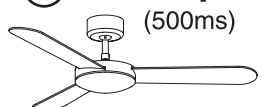

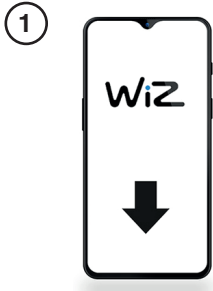

Look for APP Wizz in:
Aplicación disponible en:



Install APP and follow the steps.

Instala la aplicación y sigue los pasos.



Tap on add a new device: push "+" button at the top right.

Agrega un nuevo dispositivo pulsando el botón "+", arriba a la derecha.



Choose "ceiling fan" button.

Pulsa "ventilador de techo".



Activate Bluetooth.

Activa el Bluetooth.



Find your Wifi and add your password.

Busca tu red Wifi y pon la contraseña.



Click "continue".

Clica en "continuar".



Select "New Fan".

Selecciona "Nuevo Ventilador".

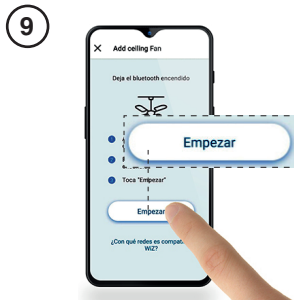

Select "Start".

Selecciona "Empezar".



Wait until Wizz find your ceiling fan. If it doesn't work go straight to page 8.
Espera hasta que Wizz encuentre tu ventilador. *En caso que no funcione sigue los pasos de la pagina 8*

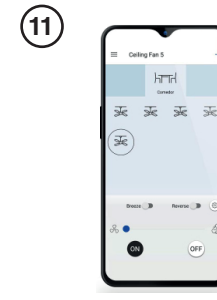

Using fan functions: On, Off, Speeds, Reverse, Breeze.
Uso de las unciones del ventilador: Encendido, Apagado, Velocidades, Función Invierno-Verano, Breeze.



Using light kit functions: On, Off, Dimmer.
Uso de las funciones del Kit de luz: Encendido, Apagado, Regulable



Go to step 8 and select manual pairing.

Vuelve a la pantalla del paso 8 y selecciona emparejamiento manual.

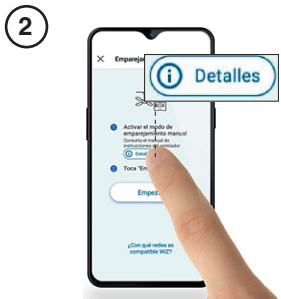

Select "Details"

Selecciona "Detalles"



Follow "manual repair" information.

Sigue las indicaciones de "emparejamiento manual".

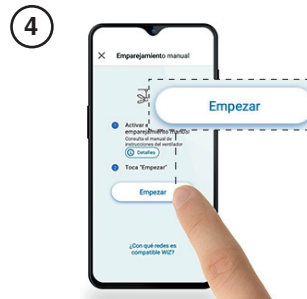

Select "Start".

Selecciona "Empezar".



Push 10 sec "reverse function" in your RC or until you hear "beep".
Pulsa 10 seg "función inversa" en tu mando a distancia o hasta que oigas un "beep".

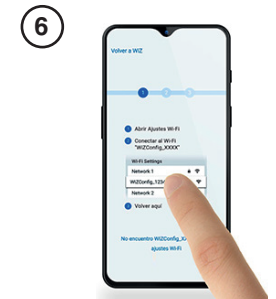

Find your WiFi and add your password.

Busca tu red WiFi y pon la contraseña.

Serie 34150: Smart Receiver

Receiving Frequences: 433MHz & 315MHz

Connectivity: 2,4GHz WiFi and Bluetooth

Working: 100V-240V~ 50Hz/60Hz

Works with: WI-FI+Bluetooth I

GOOGLE Assistant | SIRI Shorcuts

Download APP: iPhone on App Store | Andorid on Google Play | QR inside

Serie 34151: Dimm Smart Receiver

Receiving Frequences: 433MHz & 315MHz

Connectivity: 2,4GHz WiFi and Bluetooth

Working: 100V-240V~ 50Hz/60Hz

Works with: WI-FI+Bluetooth I

GOOGLE Assistant | SIRI Shorcuts

Download APP: iPhone on App Store | Andorid on Google Play | QR inside

EU DECLARATION OF CONFORMITY

Hereby, LOREFAR, SL declares that the radio equipment refs 34150, 34151 are in compliance with Directives:

2014/53/EU (RED equip)

2015/863/EU (Rohs)

2014/35/EU (LVD)

The conformity of the designated product(s) with the provisions of the European Directives is given by the compliance with the following European Standard(s) or other specifications. If not elsewhere/otherwise indicated the edition/ amendment as referenced below applies:

REMOTE

EMC

■ EN 301489-1 v2.2.3 ElectroMagnetic Compatibility (EMC) standard for radio equipment and services; Part 1: Common technical requirements.

■ EN 301489-3 v2.1.2 ElectroMagnetic Compatibility (EMC) standard for radio equipment and services; Part 3: Specific conditions for Short Range Devices (SRD) operating on frequencies between 9 kHz and 246 GHz.

RADIO

■ EN 300220-1 v3.1.1 hort Range Devices (SRD) operating in the frequency range 25 MHz to 1 000 MHz; Part 1: Technical characteristics and methods of measurement.

■ EN 300 220-2 v3.1.1 Short Range Devices (SRD) operating in the frequency range 25 MHz to 1 000 MHz; Part 2 Harmonised Standard covering the essential requirements of article 3.2 of Directive 2014/53/EU for non specific radio equipment.

DECLARACIÓN UE DE CONFORMIDAD

Por la presente, LOREAR, SL declara que el tipo de equipo radioeléctrico 34150, 34151 es conforme con las Directivas:

2014/53/UE (Equipos RED)

2015/863/UE (Rohs)

2014/35/UE (LVD)

La conformidad del producto(s) designado(s) con las disposiciones de las Directivas Europeas viene dada por el cumplimiento de la(s) siguiente(s) Norma(s) Europea(s) u otras especificaciones. Si no se indica en otra parte/de lo contrario, se aplica la edición/enmienda como se indica a continuación:

MANDO

EMC

■ EN 301489-1 v2.2.3 Estándar de Compatibilidad Electromagnética (EMC) para equipos y servicios de radio; Parte 1: Requisitos técnicos comunes

■ EN 301 489-3 v2.1.2 Norma de Compatibilidad Electromagnética (CEM) para los equipos y servicios radioeléctricos. Parte 3: Condiciones específicas para los dispositivos de corto alcance (SRD) que funcionan en las frecuencias comprendidas entre 9 kHz y 246 GHz.

RADIO

■ UNE EN 300 220-1 v3.1.1 Dispositivos de corto alcance (SRD) que operan en el rango de frecuencias de 25 MHz a 1 000 MHz; Parte 1: Características técnicas y métodos de medida.

■ UNE EN 300 220-2 v3.1.1 Dispositivos de corto alcance (SRD) que operan en el rango de frecuencias de 25 MHz a 1 000 MHz; Parte 2: Norma armonizada que cubre los requisitos esenciales según el artículo 3.2 de la Directiva 2014/53/UE para dispositivos de corto alcance no específicos.

Date of signatures: 12th May 2022

Signed by: Antonio Rosell
Chief Quality Manager