



# CODEPROX-N



## INSTALLER MANUAL

IM\_ENG\_REV0126\_CODEPROX-N

**1.TABLE OF CONTENTS**

2.INTRODUCTION .....	3
3.SPECIFICATIONS.....	3
4.PRODUCT CONTENT.....	3
5.INSTALLATION.....	3
6.CONNECTION.....	4
7.BASIC PROGRAMMING.....	4
8.ADVANCED PROGRAMMING .....	5
8.1. PROGRAMMING .....	5
8.1.1.CHANGE MASTER CODE .....	5
8.1.2.CARD REGISTRATION .....	6
8.1.3.CARD REGISTRATION .....	6
8.1.4.PIN REGISTRATION .....	6
8.1.5.PIN REGISTRATION.....	6
8.1.6.PIN DELETION.....	6
8.1.7.CARD DELETION .....	6
8.1.8.DELETING CARDS OR PIN .....	6
8.1.9.MODIFY PIN .....	6
9.OTHER SETTINGS.....	7
9.1. IDENTIFICATION MODE .....	7
9.1.1.IDENTIFICATION BY CARD OR PIN .....	7
9.1.2.IDENTIFICATION BY CARD ONLY .....	7
9.1.2.IDENTIFICATION BY PIN ONLY .....	7
9.2. RELAY SETTINGS .....	7
9.2.1.PULSE MODE.....	7
9.2.2.LATCHING MODE.....	7
9.3. ALARM SETTINGS .....	7
9.3.1.ACTIVATE TAMPER.....	7
9.4. LOCKOUT ALARM.....	7
9.4.1.LOCKOUT DISABLED.....	7
9.4.2.10-MINUTES ACCESS LOCKOUT .....	7
9.4.3.ALARM.....	8
9.5. RESET TO FACTORY DEFAULTS .....	8
10.STATUS DISPLAYS .....	8
11.CONNECTION DIAGRAMS.....	8
11.1. CONNECTION DIAGRAM WITH DC LOCK RELEASE.....	8
11.2. CONNECTION DIAGRAM WITH AC LOCK RELEASE .....	9
11.3. CONNECTION DIAGRAM WITH INTERCOM .....	9
12.WIEGAND .....	10
12.1. CONNECTION DIAGRAM WITH WCONTROL MINI CONTROLLER .....	10
12.2. CONNECTION DIAGRAM WITH iP-OPENER .....	10
12.3. PROGRAMMING .....	10
12.3.1.PROGRAMMING ON WCONTROL CONTROLLER.....	10
12.3.2.PROGRAMMING ON iP-OPENER.....	11
13.TYPES OF INSTALLATION .....	11
13.1. STAND-ALONE INSTALLATION.....	11
13.2. INSTALLATION ON NEXA PANEL .....	12
14.ANNEX.....	12
14.1. BUZZER SETTINGS .....	12
14.2. LED SETTINGS .....	12
14.3. KEYPAD TRANSMISSION FORMAT SETTINGS .....	13

## 2.INTRODUCTION





Installation manual for CODEPROX-N reader version B (20720011B), stand-alone and slave reader with proximity and PIN identification.



## 3.SPECIFICATIONS

Material	Stainless steel and black ABS plastic
Protection degree	IP-66
Input voltage	12/18Vdc
Current	Standby current: ≤ 30mA / Active: ≤ 120mA
Capacity	990 users
Keypad	12 keys
Reading frequency	EM 125KHz
Reading range	0-6cm
Relay	NO, NC, common 2A max.
Transmission format	Wiegand 26
Keypad transmission format	4 bits, 8 bits or virtual card number
Dimension (H x W x D):	Electronics: 48(W) x 62(H) x 25(D)mm. Electronics plus front cover: 86(W) x 86(H) x 25(D)mm
Working temperature range:	-40 ~60° C
Working humidity range:	10-98% (non-condensing)

## 4.PRODUCT CONTENT

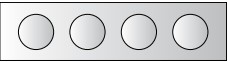
 <p>Lector CODEPROX-N</p>		Diode.
		Varistors.
		Fixing blocks.
		Screws.
		Screw cover labels.

## 5.INSTALLATION

This reader is intended for mounting/integration in Nexa panels, which requires the use of an adapter module. However, it can also be mounted independently on a specific embedding box (universal embedding box is not valid).

See chapter “13. TYPES OF INSTALLATION” to proceed.

## 6.CONNECTION

WIRE COLOR	FUNCTION	DESCRIPTION
Red	12Vdc	Input 12-18V DC current
Black	GND	GND
Blue	NO	Normally open relay output
Brown	Common	Common contact for relay output
Grey	NC	Normally closed relay output
Yellow	Opening	Exit pushbutton
Green	D0	Wiegand Data 0 output
White	D1	Wiegand Data 1 output

## 7.BASIC PROGRAMMING

Basic programming (user registration/deletion):

### USER REGISTRATION

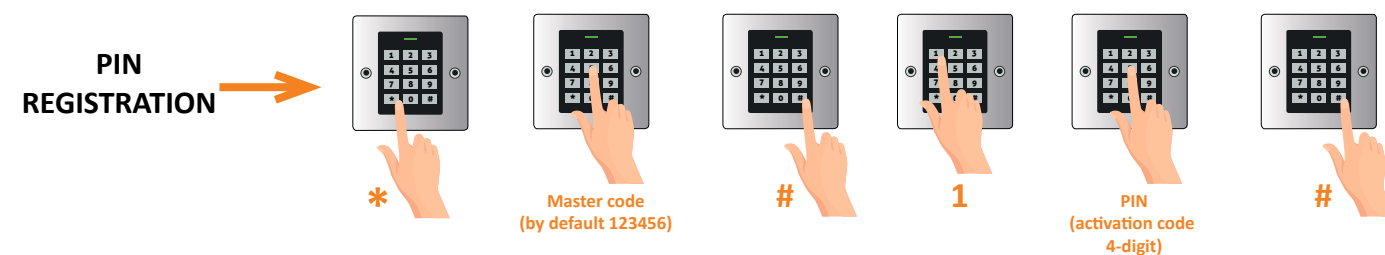

### USER DELETION

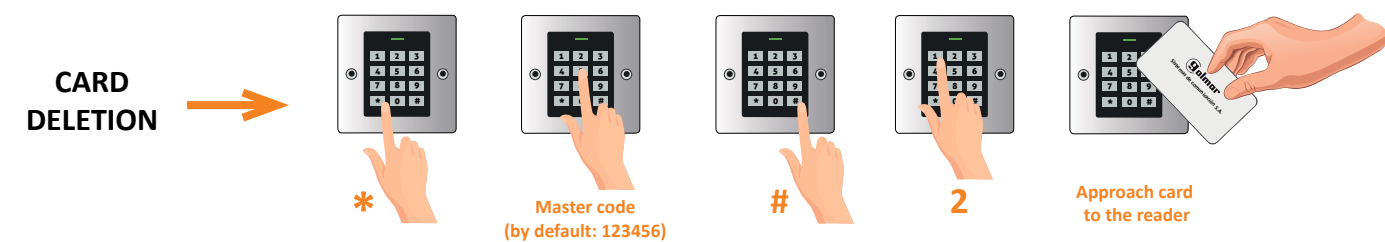

**BASIC PROGRAMMING WITH MASTER CARD**

It is possible to perform basic programming using a MASTER card. To do this, a MASTER card must be created by following the procedure described in chapter “9.4. Reset to factory settings”.

Once the MASTER card has been created, you can proceed as described below to perform basic programming:

**USER REGISTRATION**

1) Approach the “Master Card” card to the reader.

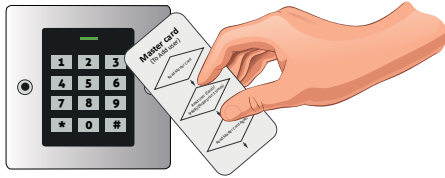

2) Approach the card or enter PIN to register.

\*For PIN enter 4 to 6 digit PIN plus #.



3) Approach the “Master Card” card to the reader.

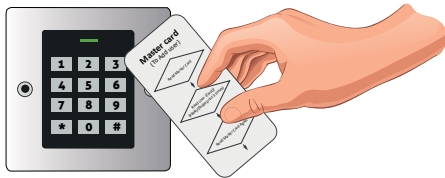

**USER DELETION**

1) Approach the “Master Card” card to the reader 2 times at an interval shorter than 5 seconds.



2) Approach card or enter PIN to delete.

\*For PIN enter 4 to 6 digit PIN plus #.



3) Approach the “Master Card” card to the reader.

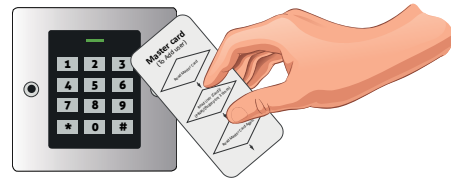

**NOTE**

In case of loss of the MASTER CARD it is possible to replace the previous one by performing again the process described in chapter “9.4.Reset to factory settings”.

**8.ADVANCED PROGRAMMING**

**8.1. PROGRAMMING**

Perform the following sequence to enter programming:

Enter to administrator mode		
*	MASTER CODE (by default: 123456)	#

**IMPORTANT**

The reader will indicate the access to programming with the “green” lighting up and then the flashing LED in “red”. At the start of the programming sequence (function to be programmed) the led will be “orange”.

To exit programming, press “\*” and the reader will go to standby, the status LED will be “steady red”. If you do not press anything, after 30 seconds the reader will also automatically exit programming.

Once in programming, perform the desired programming sequence. The different system programming sequences are detailed below.

**8.1.1.CHANGE MASTER CODE**

It is highly recommended to modify the master code:

Enter administrator mode								
*	MASTER CODE	#	0	NEW MASTER CODE (6 DIGITS)	#	NEW MASTER CODE (6 DIGITS)	#	

Example: \* 123456 # 0 987654 # 987654 #

**8.1.2.CARD REGISTRATION (AUTO ID)**

Card registration with automatic registration.

Enter administrator mode				
*	MASTER CODE	#	1	APPROACH CARD

Example: \* 987654 # 1 APPROACH CARD

**8.1.3.CARD REGISTRATION (specific ID)**

Maximum number of records is 990. User IDs from 0 to 989.

Enter administrator mode						
*	MASTER CODE	#	1	USER ID (0-989)	#	APPROACH CARD

Example: \* 987654 # 1 1 # APPROACH CARD

IMPORTANT: do not enter user IDs with zeros before the ID value.

**8.1.4.PIN REGISTRATION (AUTO ID)**

PIN registration with automatic recording position.

Enter administrator mode					
*	MASTER CODE	#	1	PIN	#

Example: \* 987654 # 1 4543 #

**8.1.5.PIN REGISTRATION (specific ID)**

Maximum number of records is 990. User IDs from 0 to 989.

Enter administrator mode							
*	MASTER CODE	#	1	USER ID (0-989)	#	PIN	#

Example: \* 987654 # 1 1 # 4543 #

IMPORTANT: do not enter user IDs with zeros before the ID value.

**8.1.6.PIN DELETION**

PIN deletion by entering the PIN number to be deleted.

Enter administrator mode					
*	MASTER CODE	#	2	INTRODUCE PIN	#

Example: \* 987654 # 2 4543 #

**8.1.7.CARD DELETION**

Deletion of cards by approaching the card to be deleted.

Enter administrator mode				
*	MASTER CODE	#	2	APPROACH CARD

Example: \* 987654 # 2 APPROACH CARD

**8.1.8.DELETING CARDS OR PIN (specific ID)**

Enter the ID corresponding to the user to be deleted.

Enter administrator mode					
*	MASTER CODE	#	2	USER ID (0-989)	#

Example: \* 987654 # 2 1 #

**8.1.9.MODIFY PIN**

It is possible to change the PIN, but it is not necessary to access programming. When the reader is in standby mode, enter:

*	USER ID	#	PIN TO MODIFY	#	NEW PIN	#	NEW PIN	#
---	---------	---	---------------	---	---------	---	---------	---

Example: \* 1 # 4543 # 6688 # 6688 #

## 9. OTHER SETTINGS

### 9.1. IDENTIFICATION MODE

#### 9.1.1. IDENTIFICATION BY CARD OR PIN (default value)

Enter administrator mode				
*	MASTER CODE	#	43	#

Example: \* 987654 # 43 #

#### 9.1.2. IDENTIFICATION BY CARD ONLY

Enter administrator mode				
*	MASTER CODE	#	40	#

Example: \* 987654 # 40 #

#### 9.1.2. IDENTIFICATION BY PIN ONLY

Enter administrator mode				
*	MASTER CODE	#	41	#

Example: \* 987654 # 41 #

## 9.2. RELAY SETTINGS

### 9.2.1. PULSE MODE

Enter administrator mode					
*	MASTER CODE	#	3	1-99	#

Example: \* 987654 # 3 15 #

The pulse can be active from 1 to 99 seconds. In the example, the value 15 has been entered, so it would be active for 15 seconds. Default value: 5s.

### 9.2.2. LATCHING MODE

Enter administrator mode					
*	MASTER CODE	#	3	0	#

Example: \* 987654 # 3 0 #

## 9.3. ALARM SETTINGS (TAMPER)

### 9.3.1. ACTIVATE TAMPER

Enter administrator mode				
*	MASTER CODE	#	5(0-3)	#

Example: \* 987654 # 52 #

The tamper alarm activation time is from 0 to 3 minutes. In the example, the value 52 has been entered, so it would be active for 2 minutes. Default value: 51 (1 minute).

## 9.4. LOCKOUT ALARM (FAILED ATTEMPTS)

The lockout alarm will be triggered after 10 unsuccessful card/PIN entry attempts. The factory default is OFF, but it can be set to deny access for 10 minutes or to activate the alarm after triggering.

### 9.4.1. LOCKOUT DISABLED (default value)

Enter administrator mode				
*	MASTER CODE	#	60	#

Example: \* 987654 # 60 #

### 9.4.2. 10-MINUTES ACCESS LOCKOUT

Enter administrator mode				
*	MASTER CODE	#	61	#

Example: \* 987654 # 61 #

The LED will start blinking and the reader will be locked for 10 minutes. To return to the normal state, wait 10 minutes or restart the reader.

**9.4.3.ALARM**

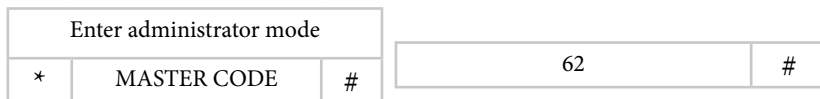

Example: \* 987654 # 62 #

In case a valid user card or MASTER card is approached, the alarm will stop.

**9.5. RESET TO FACTORY DEFAULTS**

The reset returns the reader to factory defaults. Restoring the configuration and the master code. User information will be kept.

1. Turn off the power.
2. Press and hold the exit push button.
3. Turn on the power.
4. When 2 beeps are heard, stop holding the exit pushbutton.
5. The LED will light up yellow.
6. Approach a 125KHz card through the reader
7. The light will illuminate red and the equipment will be reset to factory defaults.

\*Requires exit push button, yellow wire (OPEN) and black wire (GND) to be connected.

**NOTE**

- This process generates a MASTER card replacing the previous one.
- In case it is not desired to replace the current MASTER card, skip step 6 and wait for the reader to return to the idle state (red led).

**10.5. DELETION OF ALL USERS**



Example: \* 987654 # 2 987654 #

**IMPORTANT:**

Before performing this function, make sure that it is OK to REMOVE all previously registered users.

**10.STATUS DISPLAYS**

OPERATING STATUS	COLOUR LED	BUZZER
Stand by	Rojo	-
Enter programming mode	Flashing red	Short beep
In programming mode	Orange	Short beep
Operation error	-	3 beeps
Exit programming mode	Red	Short beep
Door open	Green	Short beep
Alarm	Flashing red	Beeps

**11.CONNECTION DIAGRAMS**

**11.1. CONNECTION DIAGRAM WITH DC LOCK RELEASE**

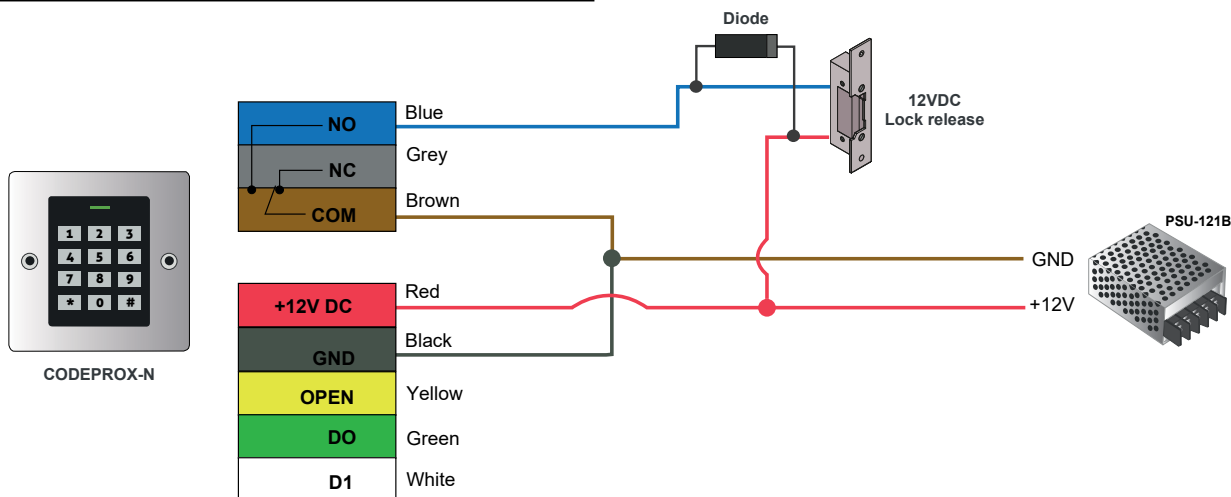

**IMPORTANT:** Do not forget to connect the supplied diode in parallel to the lock release to protect the equipment.

**11.2. CONNECTION DIAGRAM WITH AC LOCK RELEASE**

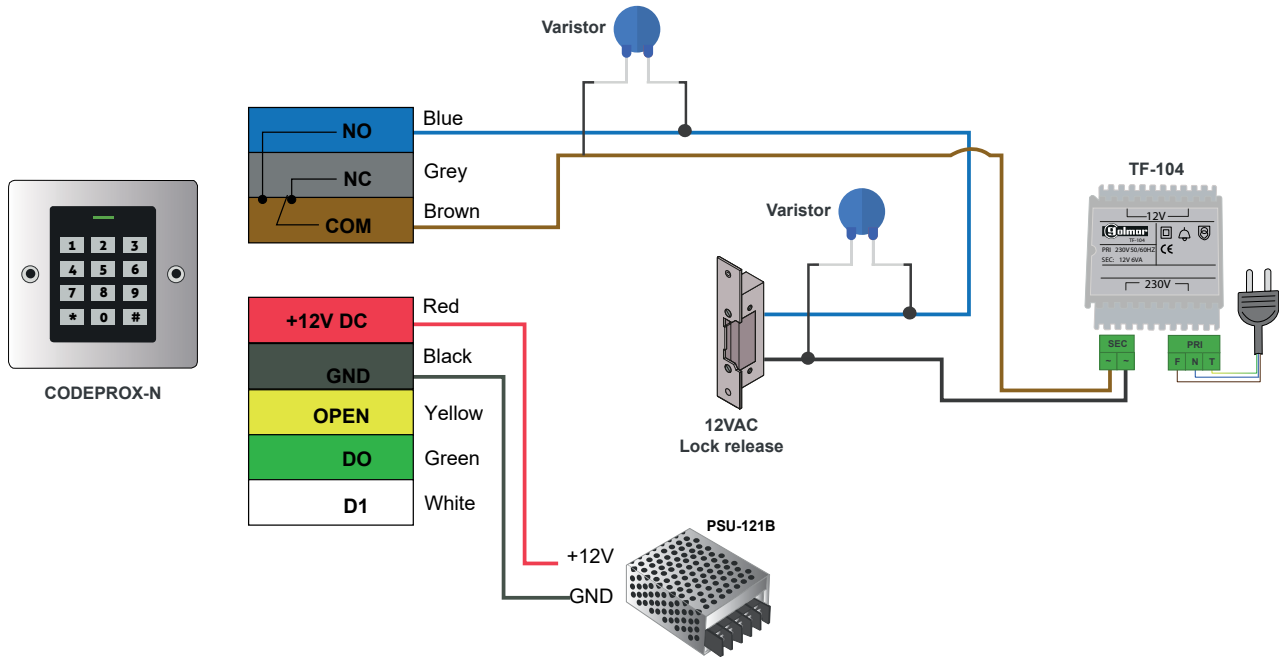

**IMPORTANT:** Golmar recommends using DC lock releases, as connecting an AC lock release may cause high voltage spikes that could damage the device or cause it to malfunction. However, in the event the AC lock release is used, protect the equipment by fitting a varistor to the relay contact output and another in parallel with the lock release.

**11.3. CONNECTION DIAGRAM WITH INTERCOM**

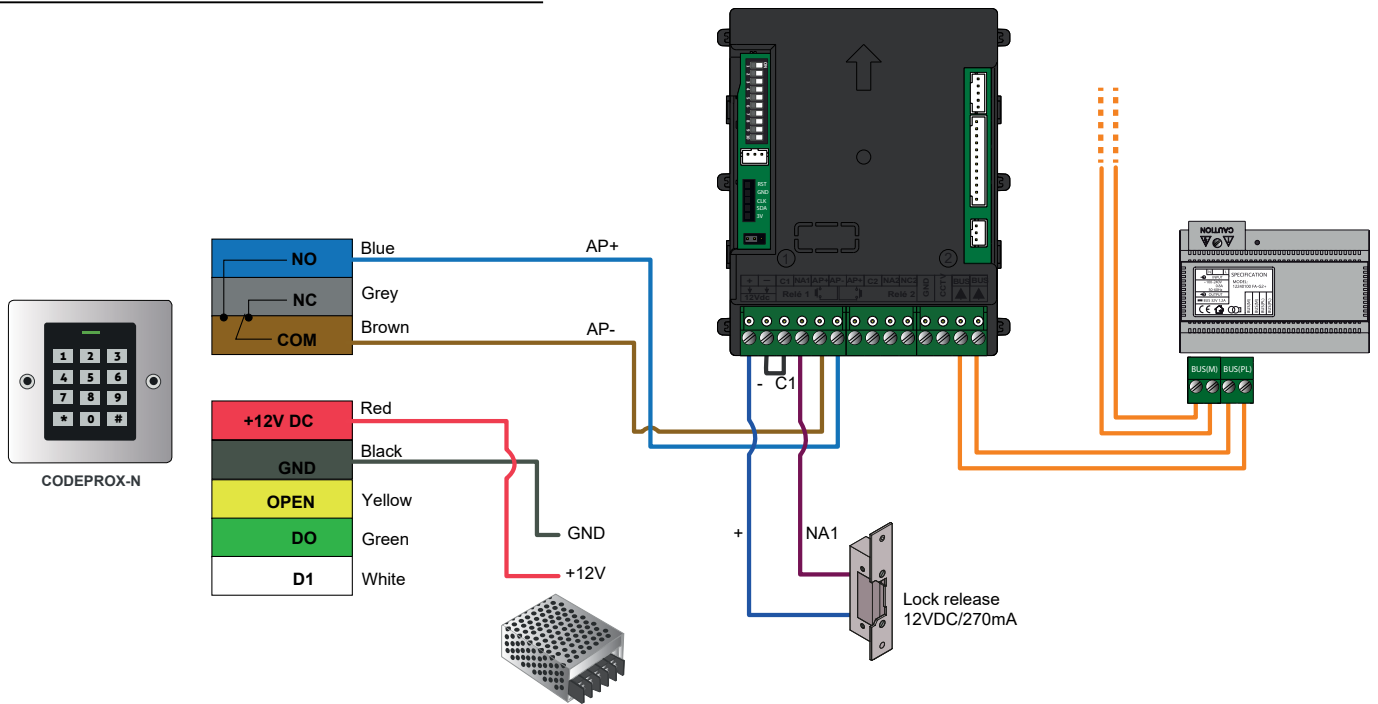

**NOTE:** The door opener (AP) does not activate the lock release until the pulse on the CODEPROX-N reader has been finished. To avoid opening delays set the minimum pulse time to 1 second at the reader:

Enter administrator mode					
*	MASTER CODE	#	3	1	#

## 12. WIEGAND

### 12.1. CONNECTION DIAGRAM WITH WCONTROL MINI CONTROLLER

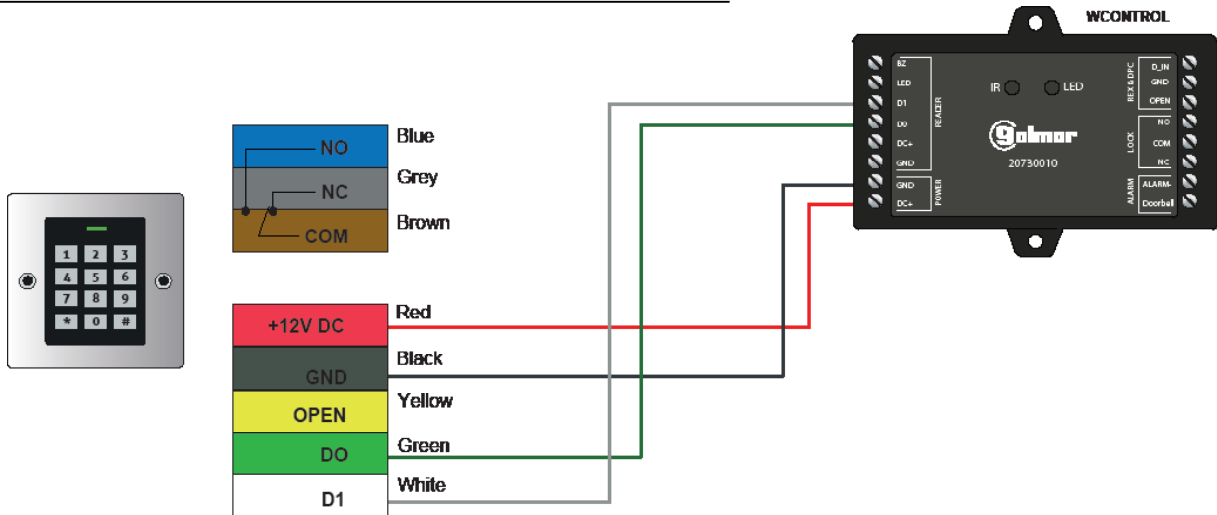

### 12.2. CONNECTION DIAGRAM WITH iP-OPENER

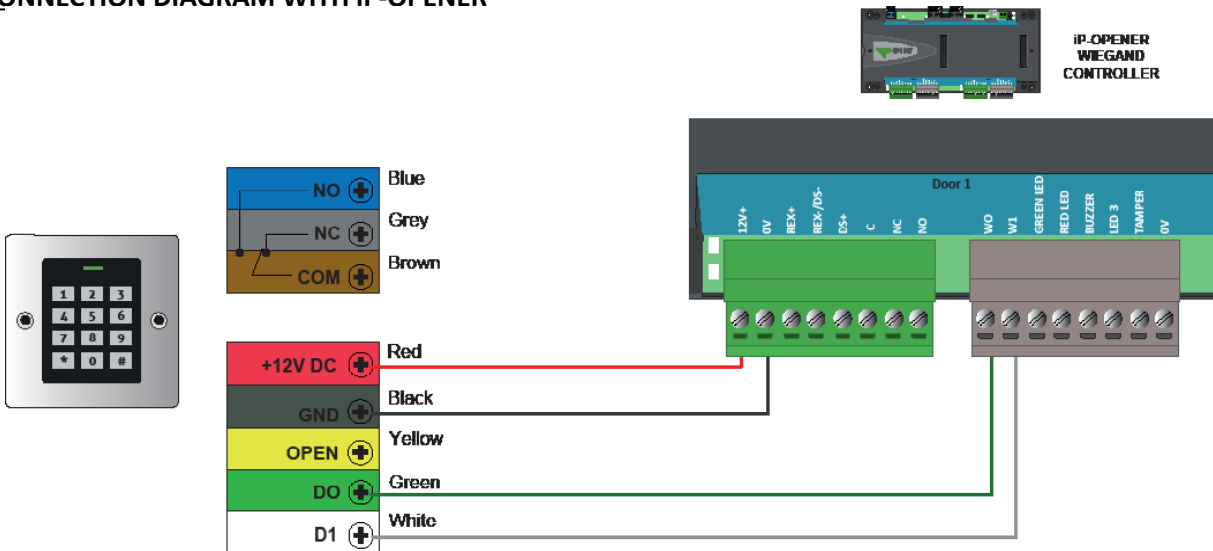

## 12.3. PROGRAMMING

### 12.3.1. PROGRAMMING ON WCONTROL CONTROLLER

Below is an overview of how to proceed with the registration of credentials in WCONTROL, for more detailed information please refer to the manual 'IM\_ESP\_REV0126\_WCONTROL'.

Perform one of the following sequences using the programming remote control to register cards to the WCONTROL controller:

#### CARD REGISTRATION (SPECIFIC ID)

Maximum number of records is 990. User IDs from 0 to 989.



Example: \* 987654 # 1 1 # APPROACH CARD

IMPORTANT: do not enter user IDs with zeros before the ID value.

#### PIN REGISTRATION (SPECIFIC ID)

Maximum number of records is 990. User IDs from 0 to 989.

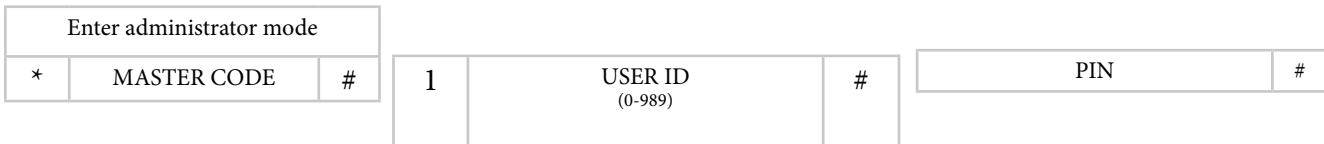

Example: \* 987654 # 1 1 # 4543 #

IMPORTANT: do not enter user IDs with zeros before the ID value.

### 12.3.2. PROGRAMMING ON iP-OPENER

Below is an overview of how to proceed with the registration of credentials in iP-Opener, for more detailed information, please refer to the manual 'USM\_ESP\_REV0126\_IPOP\_USER\_MANAGEMENT\_FINAL'.

#### EM CARD REGISTRATION

Create a user with 'Other (decimal)' credential and register the ID of the TAGKEY ID keyfob or PROKEY ID card. In case a GM-USB-125 programmer is supplied, pass the identification through the programmer after creating the 'Other (decimal)' credential.

#### PIN REGISTRATION

Generate a user with a 'Access Code' type credential and enter a 4 to 8 digit code.

## 13. TYPES OF INSTALLATION

### 13.1. STAND-ALONE INSTALLATION

As briefly mentioned in section "5.INSTALLATION", the installation of these readers is designed to be integrated in Nexa panels. However, you can choose to install the reader independently on a embedding box. In this case, follow the steps below:

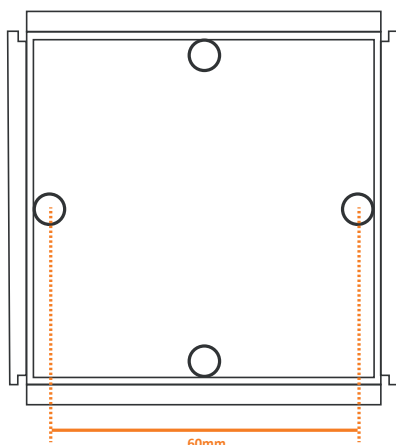

1

Place a embedding box AP-1 (20363401).

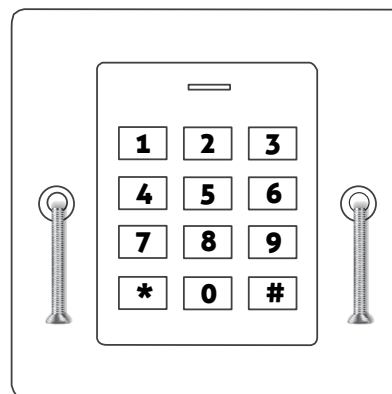

2

Attach the reader to the box with the metric screws supplied. Then cover the screws with the supplied screw cover labels.

**IMPORTANT:** The reader incorporates an anti-tamper LDR sensor on the back of the reader . It is light-sensitive, so if light shines on the sensor after placing the reader, the tamper alarm will be triggered.

### 13.2. INSTALLATION ON NEXA PANEL

To integrate the reader into modular panels, it must be acquired on a kit basis:

N3000/CODEPROX-N (20700017), mounting kit for the CODEPROX-N reader on Nexa Aluminium.

NX3000/CODEPROX-N (20700018), mounting kit for the CODEPROX-N reader on Nexa Stainless Steel.

NNX3000/CODEPROX-N BLACK (20700018B), kit for mounting the CODEPROX-N reader on Nexa Inox with a black finish.

S3000/CODEPROX-N/AL (12583305), kit for mounting the CODEPROX-N reader on Supra.

Due to the fact that the kits are supplied with the reader assembled in a special frame, as in the example below:



Front view of Nexa Aluminium cover panel with reader



Back view of Nexa Aluminium cover panel with reader

## 14.ANNEX

### 14.1. BUZZER SETTINGS

BUZZER ACTIVATED

Enter administrator mode				
*	MASTER CODE	#	71 (default value)	#

Example: \* 987654 # 71 #

BUZZER DEACTIVATED

Enter administrator mode				
*	MASTER CODE	#	70	#

Example: \* 987654 # 70 #

### 14.2. LED SETTINGS

LED ACTIVATED

Enter administrator mode				
*	MASTER CODE	#	73 (default value)	#

Example: \* 987654 # 73 #

LED DEACTIVATED

Enter administrator mode				
*	MASTER CODE	#	72	#

Example: \* 987654 # 72 #

**14.3. KEYPAD TRANSMISSION FORMAT SETTINGS**

4 BITS

Enter administrator mode				
*	MASTER CODE	#	84 (default value)	#

Example: \* 987654 # 84 #

8 BITS

Enter administrator mode				
*	MASTER CODE	#	88	#

Example: \* 987654 # 88 #

VIRTUAL CARD NUMBER

Enter administrator mode				
*	MASTER CODE	#	810	#

Example: \* 987654 # 810 #

NOTE: The reader is supplied with a 4-bit keypad transmission format setting to operate correctly with Golmar Wiegand technology controllers, resetting the reader to factory defaults will change the setting to virtual card number, please note this in case to use the reader as a slave with a controller.







C/ Silici 13. Poligon Industrial Famadas  
08940 – Cornellà del Llobregat – Spain  
golmar@golmar.es  
Tel: 93 480 06 96  
www.golmar.es



Golmar reserves the right to make any changes without notice.