

CE CE
EN14428 EN12150

GME

- ES Todas las mamparas han sido diseñadas y fabricadas de acuerdo con EN14428
Todos los cristales utilizados en nuestros productos están certificados y probados de acuerdo con EN12150
- EN All shower products are designed and manufactured according to EN14428
All the glass used on the product are certified and tested according to EN12150
- FR Toutes les parois ont été conçues et fabriquées conformément à EN14428
Toutes les verres utilisés dans nos produits sont certifiés et testés conformément à EN12150
- IT Tutti i box doccia sono stati disegnati e fabbricati in accordo con EN14428
Tutti i cristalli utilizzati nei nostri prodotti sono certificati e collaudati in accordo con EN12150

MANUAL INSTRUCCIONES

MODELO BASIC

FRONTAL 1 FIJO + 1 CORREDERA
1 FIX + 1 SLIDING DOOR



- ES VIDEO DE INSTALACIÓN
Escanea el código QR para acceder al video de instalación.
- EN INSTALLATION VIDEO
Scan the QR code to play the installation video.



IMPORTANTE

- ES La etiqueta de tratamiento antical debe quedar instalada por dentro.
El acabado de serigrafía por fuera.
- EN The anti-lime treatment sticker must be installed on the inside.
The printing glass finish outside.
- FR L'étiquette de traitement anticalcaire doit rester installée à l'intérieur.
La finition de la sérigraphie à l'extérieur.
- IT Il lato in cui è applicata la etichetta del trattamento anti calcare identifica
la parte interna del cristallo.
Il lato serigrafato va esternamente.

- ES MANUAL DE INSTALACIÓN
No tirar. Guardar el manual de instalación para un uso posterior.
- EN INSTALLATION MANUAL
Do not discard. Save the installation manual for further use.
- FR MANUEL D'INSTALLATION
Ne pas jeter. Garder le manuel d'installation pour un usage postérieur.
- IT MANUALE DI INSTALLAZIONE
Non cestinare. Conservare il manuale di installazione per un utilizzo posteriore.

GME ATENCIÓN / ATTENTION

- ES No utilizar productos de limpieza con componentes ácidos en cristales
mata serigrafiados o cualquier acabado rugoso. Usar solo jabón pH neutro o
alcohol.
- EN Don't use abrasive products or cleaning products with acid components
in print silked glasses or any rugged decoration. Use normal pH neutral soap
or alcohol.
- FR Ne pas utiliser de produits de nettoyage avec des composés acides dans
les verres mats sérigraphiés ou n'importe quel finition rugueuse. Utiliser
uniquement savon pH neutre ou alcool.
- IT Non usare prodotti di igiene con componenti acidi su cristalli opachi,
serigrafati o con qualunque finitura rugosa. Utilizzare unicamente sapone pH
neutro o alcool.



- ES Vinagre / Antical / Detergente
- EN Vinegar / Anti-lime / Detergent
- FR Vinaigre / Anticalcaire / Détergent
- IT Aceto / Anti calcare / Detergente



- ES Jabón pH neutro / Alcohol
- EN pH neutral soap / Alcohol
- FR Savon pH neutre / alcool
- IT Sapone pH neutro / Alcool



IMPORTANT INFORMATION / INFORMACIÓN IMPORTANTE / INFORMATIONS IMPORTANTES / INFORMAZIONI IMPORTANTI

- EN** • Always wear safety goggles and work gloves when installing or disassembling this product, especially when working with glass panels.
- When handling, never rest the corner of the glass directly on the floor or hit the corner with any object. This can cause the glass to break.
- Always have two persons to install or disassemble the shower.
- Small children should never use the shower unsupervised or without proper instructions for safety use.
- Small children should never hit, lean, or hang on the shower product. Nor should they do any inappropriate activity in the vicinity of the shower.
- Tempered safety glass is designed to shatter into small tiny pieces when the glass is broken, this is to avoid serious injury.
- ES** • Llevar gafas y guantes de seguridad durante la instalación o desmontaje de este producto, especialmente durante la manipulación de los cristales
- Durante la manipulación, nunca dejar descansar las esquinas de los cristales directamente en el suelo o golpearlos con cualquier objeto. Puede provocar la rotura del cristal
- Es conveniente que la instalación o el desmontaje sea llevado a cabo por dos personas.
- Los niños no deben usar la ducha sin supervisión o sin apropiadas instrucciones de uso para su seguridad
- Los niños no deben, bajo ningún concepto, golpear, apoyarse o colgarse de los productos de ducha. De la misma manera, deberán realizar actividades inapropiadas en las inmediaciones de la mampara.
- El cristal templado de seguridad ha sido diseñado para romper en pequeñas piezas con el objetivo de evitar daños mayores
- FR** • Porter des lunettes et des gants de sécurité aux cours de l'installation de ce produit, en particulier pendant la manipulation des verres.
- Pendant la manipulation ne jamais laisser reposer les coins des verres directement par terre ou les choquer avec n'importe quel objet. Cela peut provoquer la brisure du verre.
- Il est souhaitable que l'installation ou le déballage soit réalisé par deux personnes.
- Les enfants ne doivent pas, en aucun cas, choquer, s'appuyer ou se pendre des produits de douche. De la même manière ils ne devront pas réaliser des activités inappropriées à proximité de la paroi.
- Le verre tempéré de sécurité a été conçu pour casser en petites pièces afin d'éviter de plus grands dommages.
- IT** • Indossare occhiali e guanti protettivi durante l'installazione o smontaggio di questo prodotto, specialmente durante la manipolazione dei cristalli.
- Non appoggiare mai gli angoli dei cristalli direttamente al suolo o colpirli con qualunque oggetto durante la manipolazione. Il cristallo potrebbe rompersi.
- È conveniente che l'installazione o lo smontaggio siano eseguiti da due persone contemporaneamente.
- I bambini non devono usare la doccia senza la supervisione di un adulto o senza le dovute istruzioni di sicurezza
- I bambini non devono colpire, appoggiarsi o appendersi agli elementi della doccia. Non dovranno, inoltre, realizzare attività inappropriate in prossimità del box doccia.
- Il cristallo temperato di sicurezza è stato disegnato affinché si rompa in piccoli pezzi onde evitare danni maggiori.

Body part / Despiece

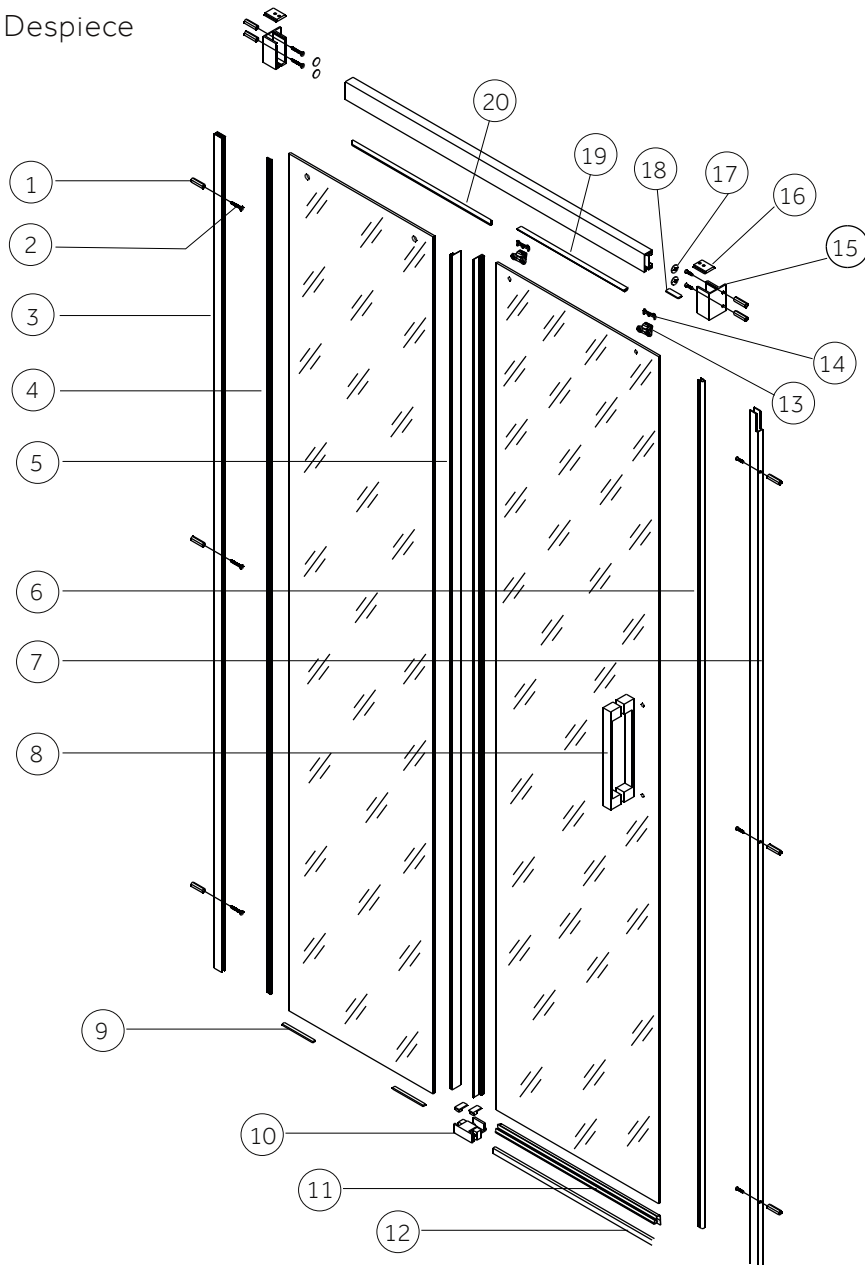

Tools/ Herramientas

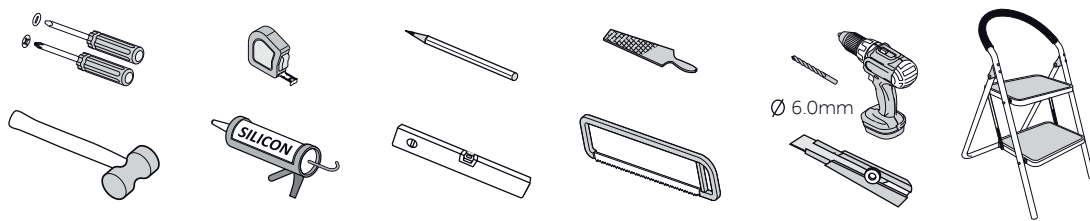

Hardware list / Lista accesorios

Num. Number	Imagen Pic	Cant. Qty.	Num. Number	Imagen Pic	Cant. Qty.	Num. Number	Imagen Pic	Cant. Qty.	Num. Number	Imagen Pic	Cant. Qty.
1		10	6		1	11		1	16		2
2		10	7		1	12		1	17		4
3		1	8		1	13		2	18		1
4		1	9		1	14		2	19		1
5		2	10		1	15		LR/ 1	20		1

1

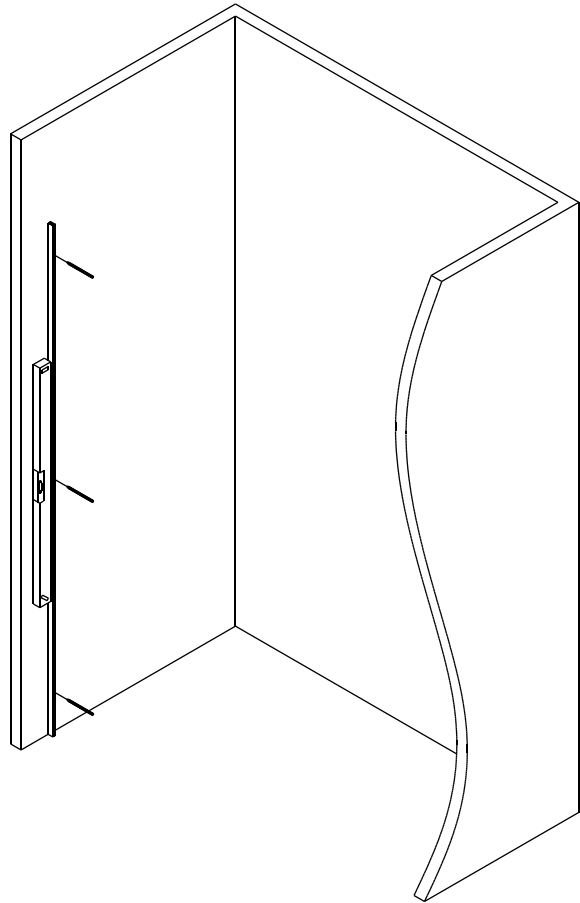

2

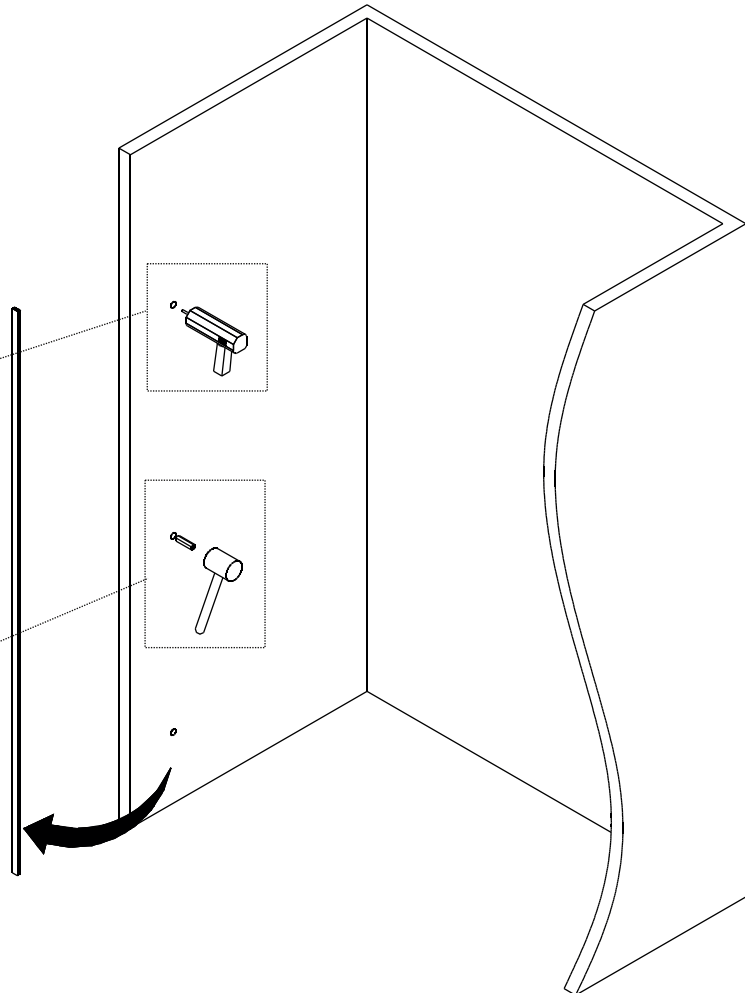
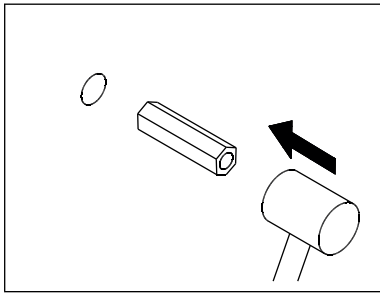
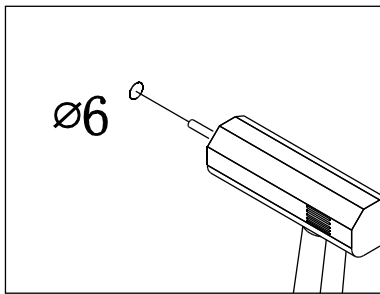

3

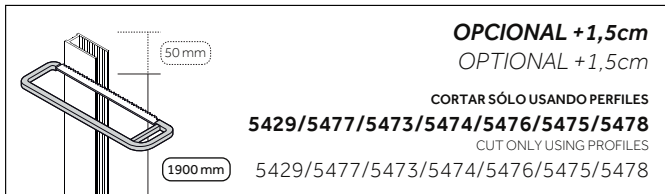
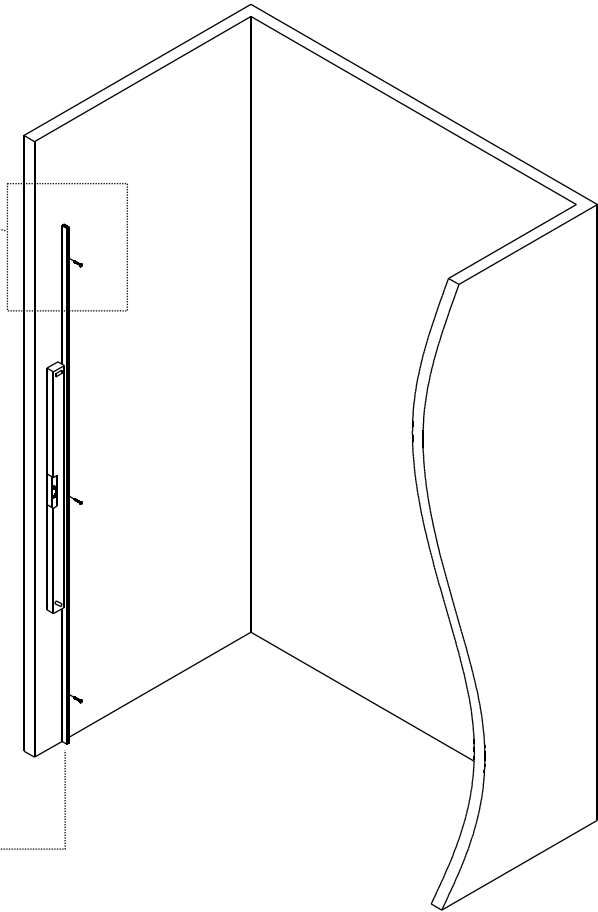
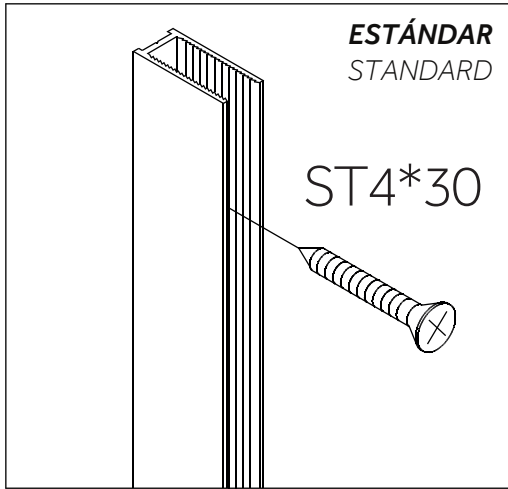

4

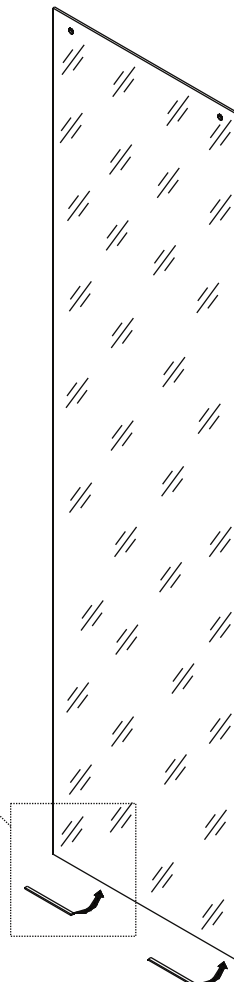
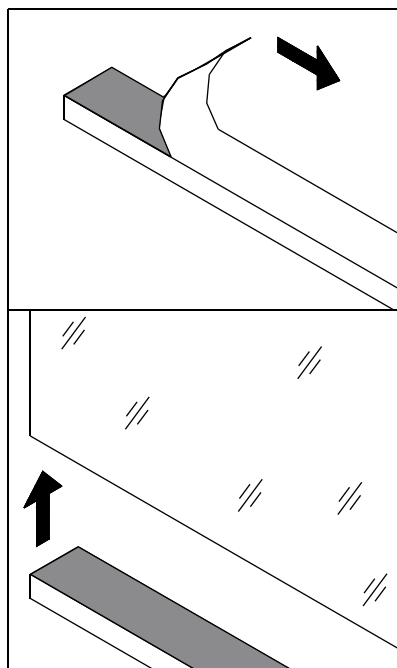

5

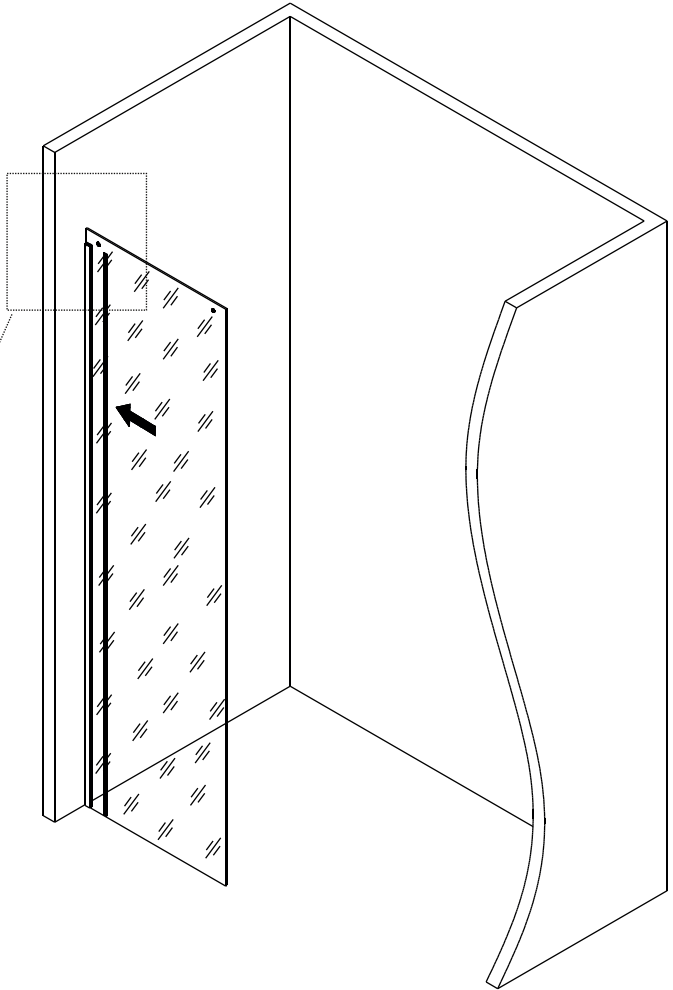
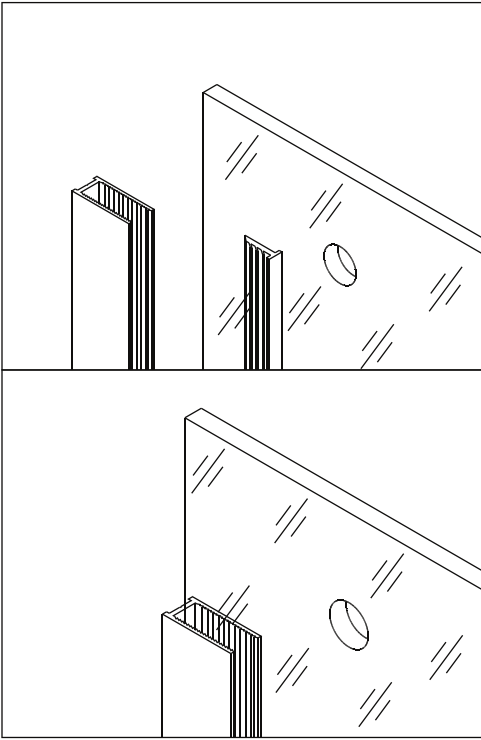

6

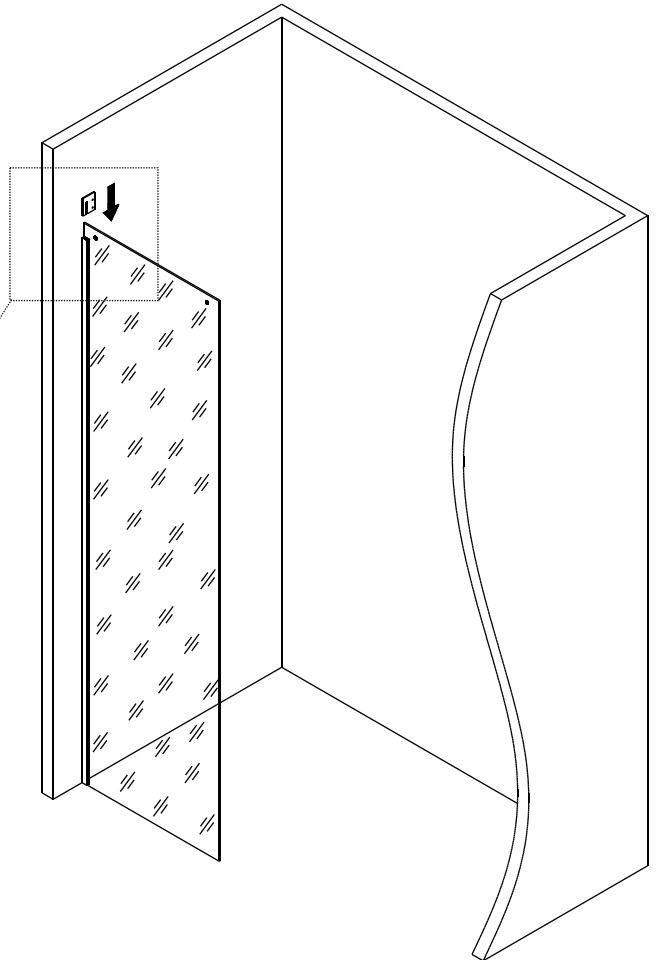
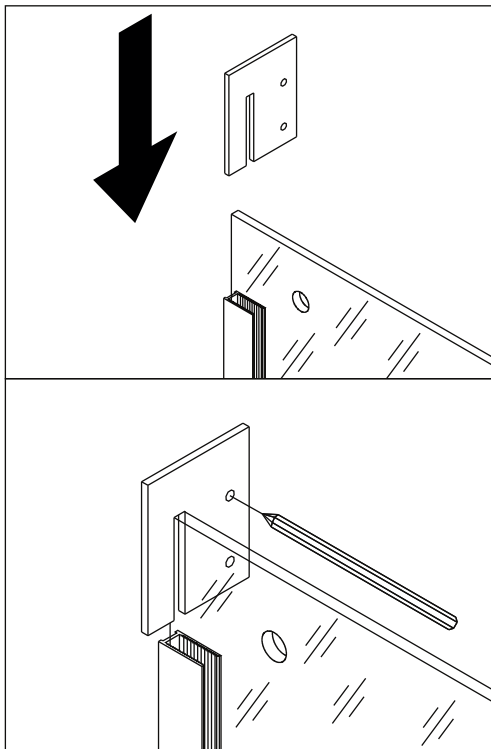

7

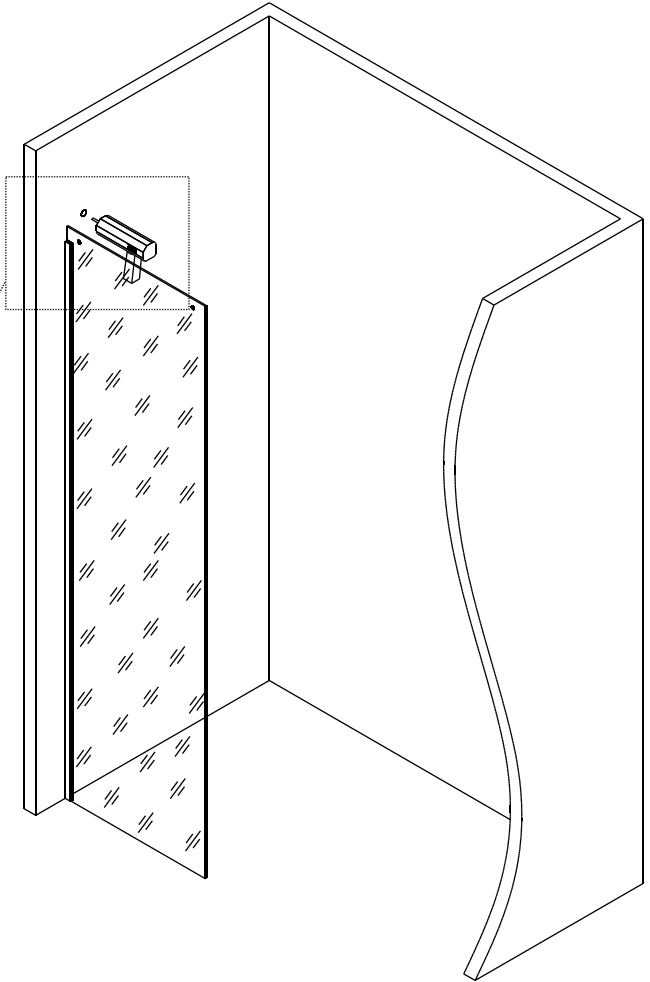
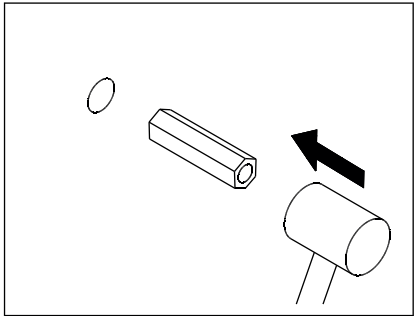
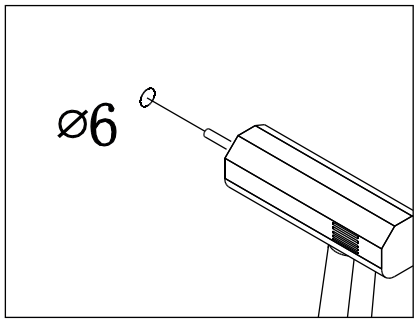

8

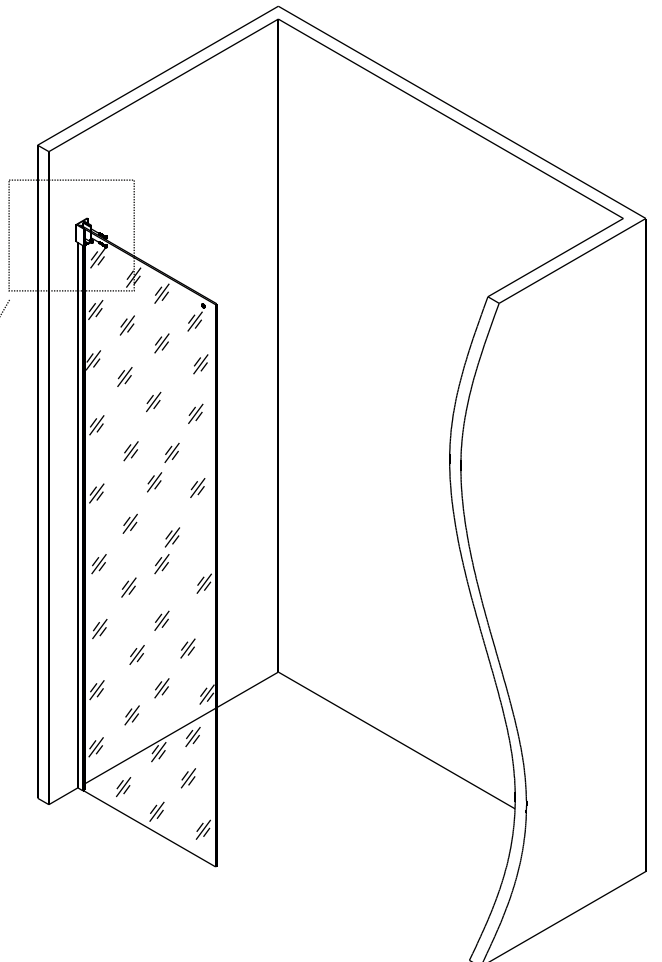
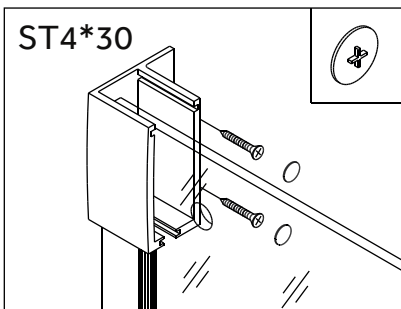
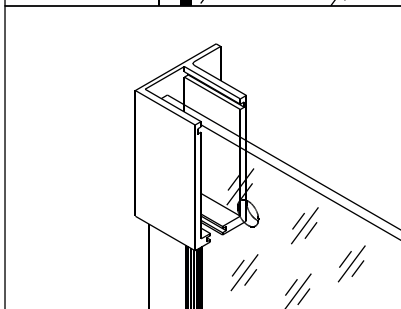
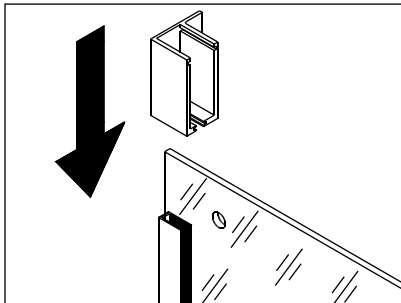

9

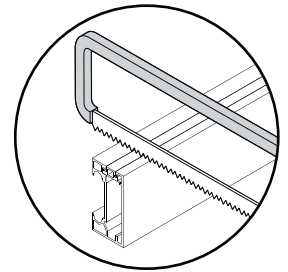
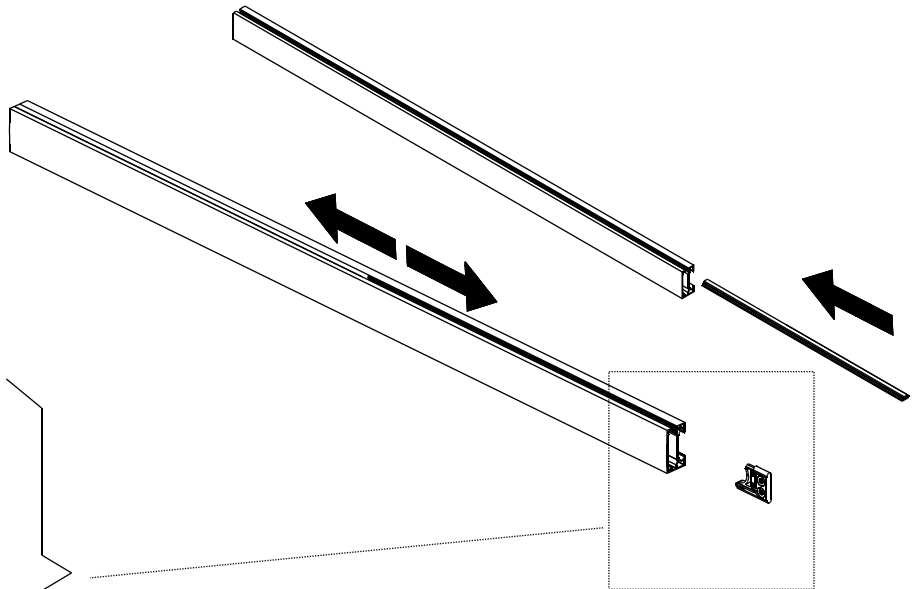
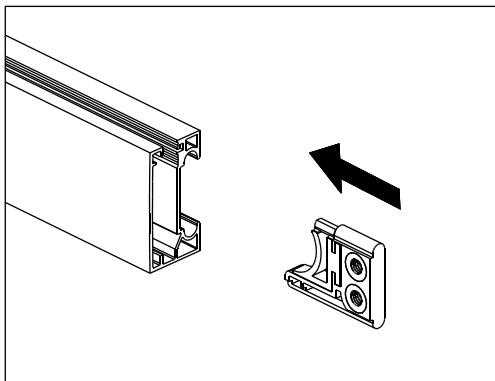
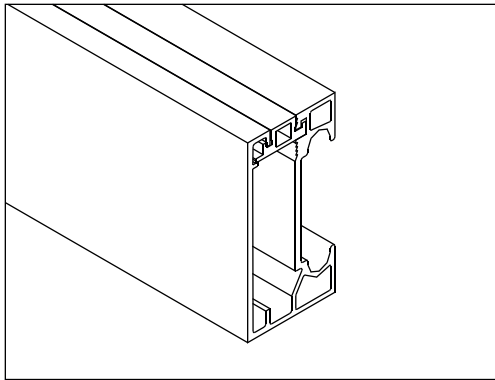

10

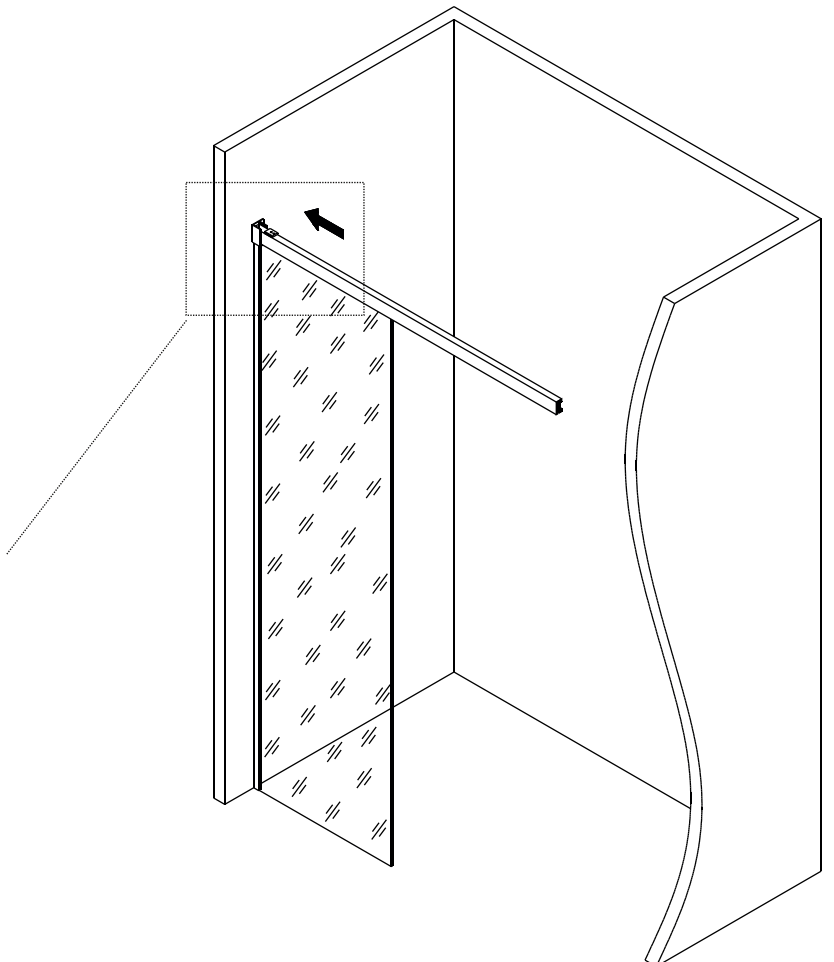
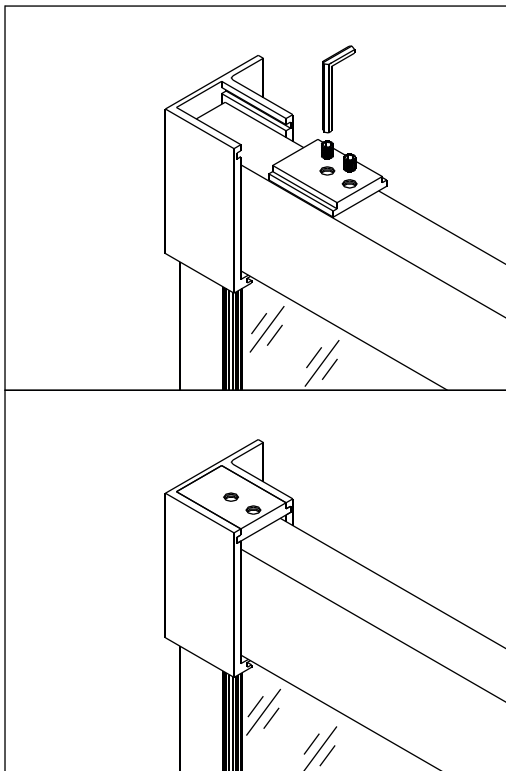

11

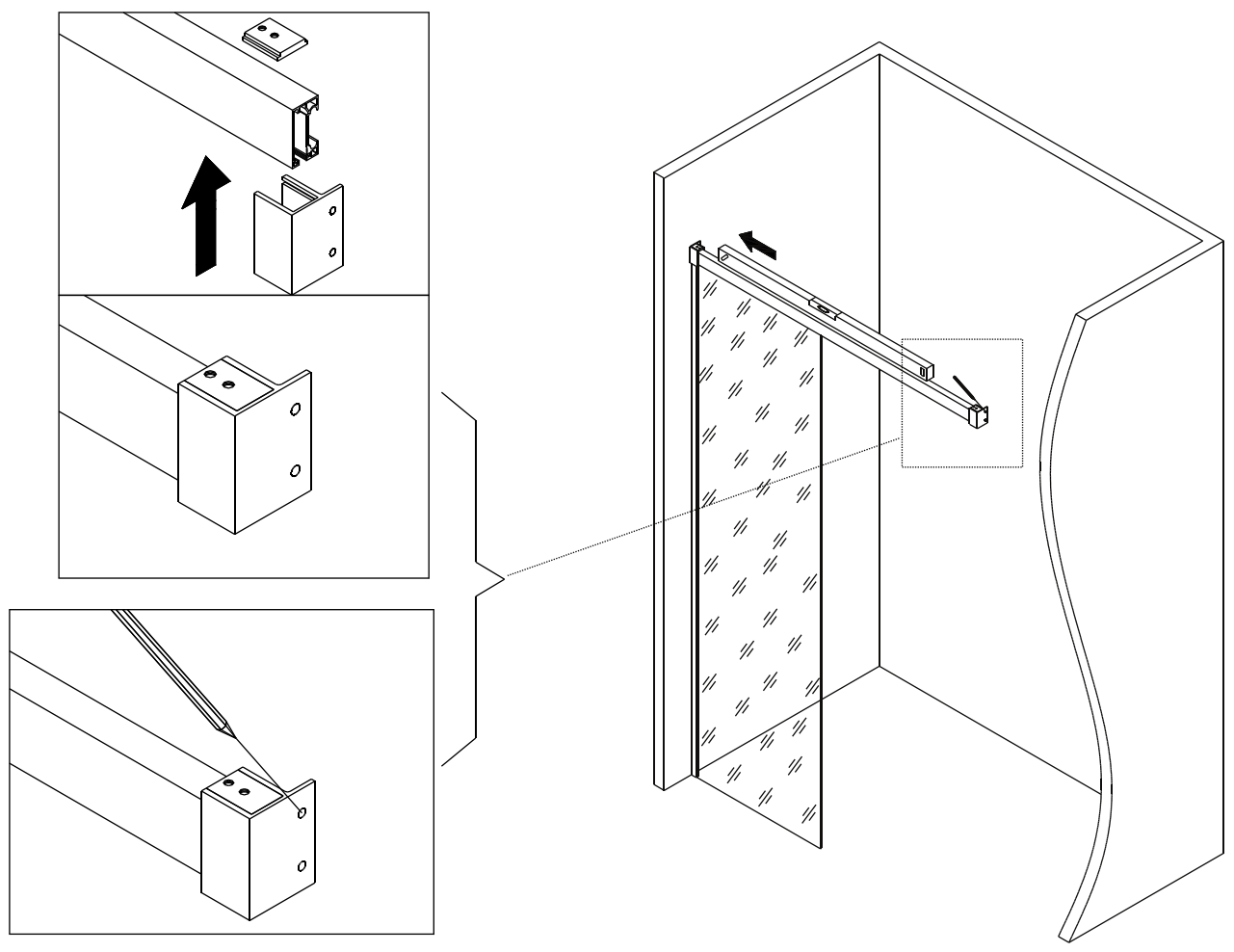

12

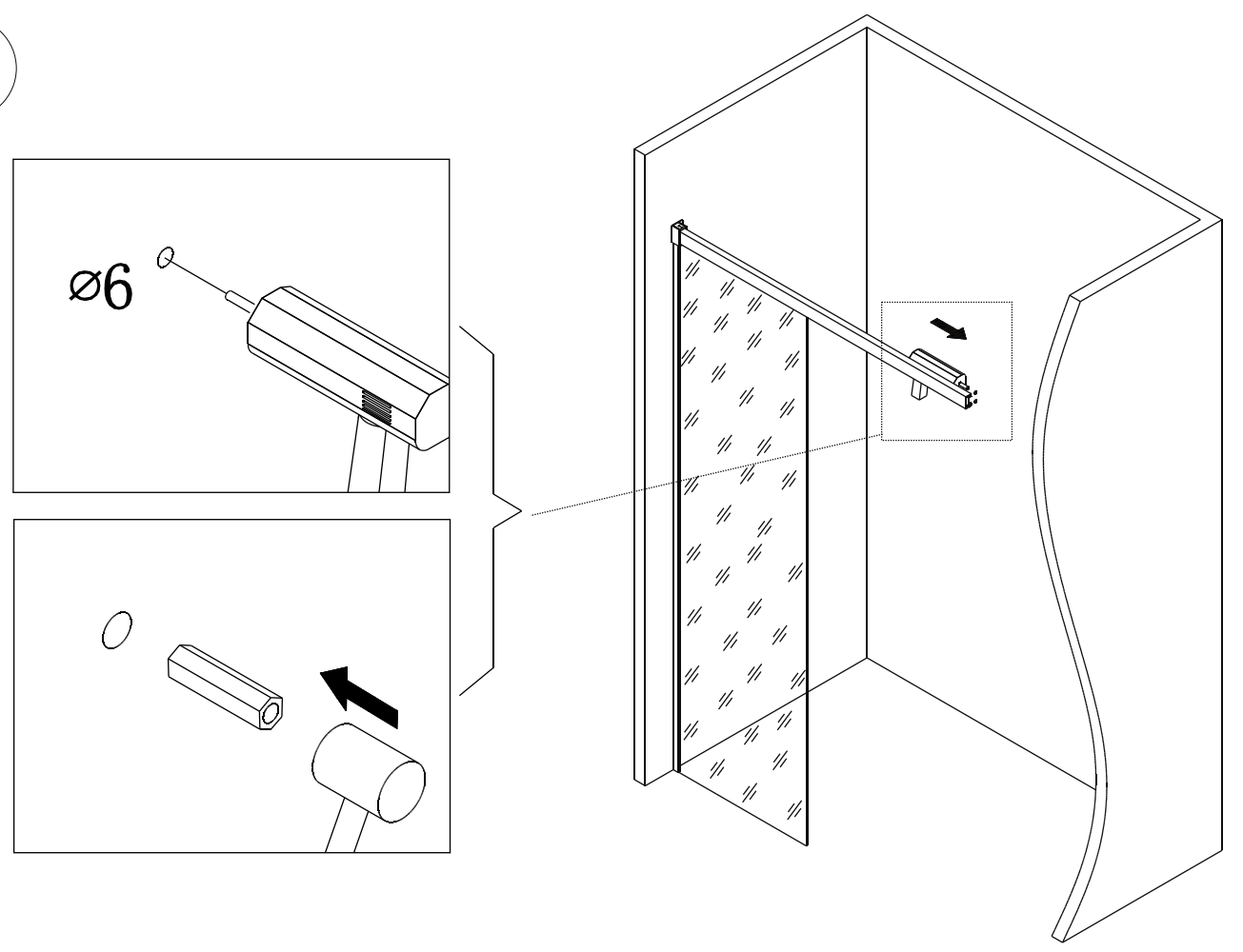

13

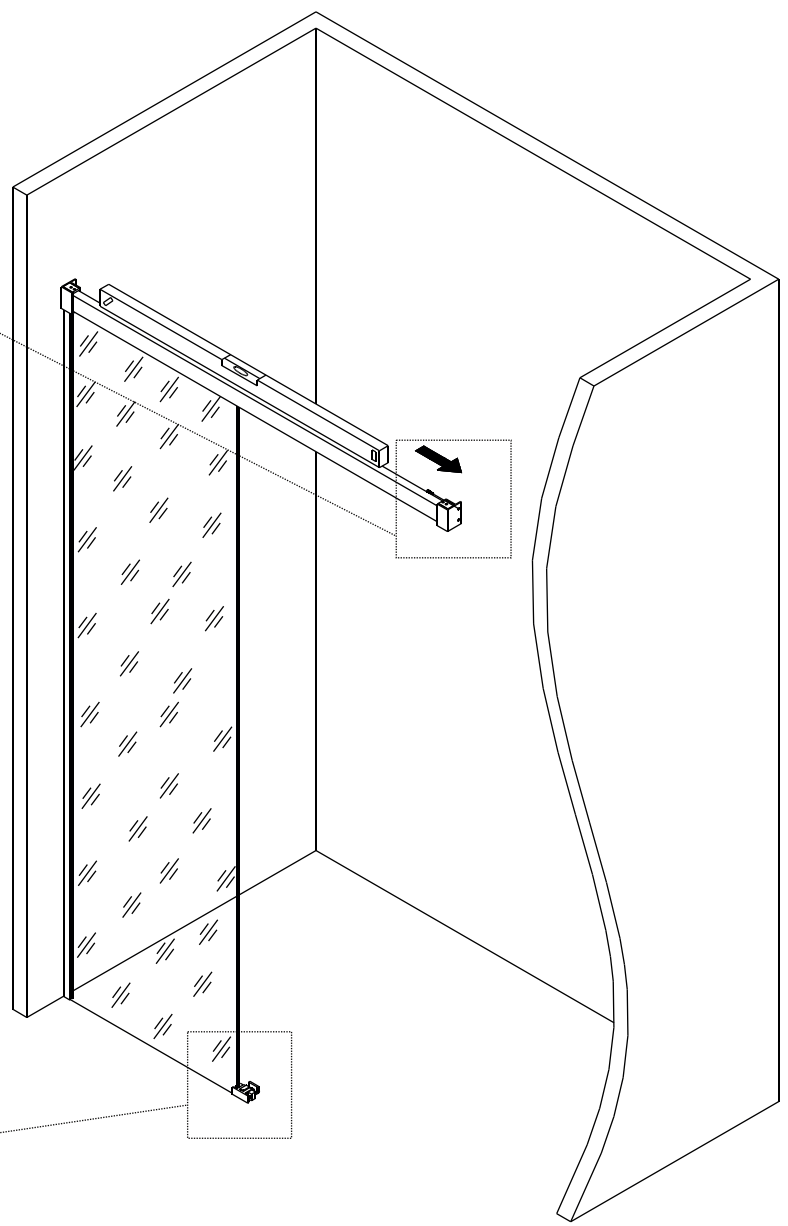
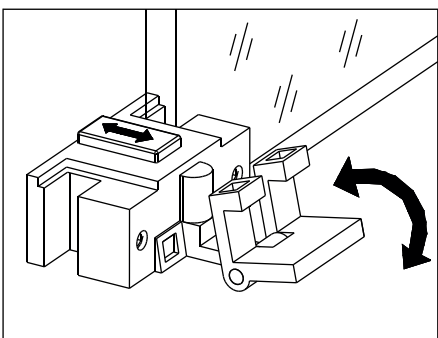
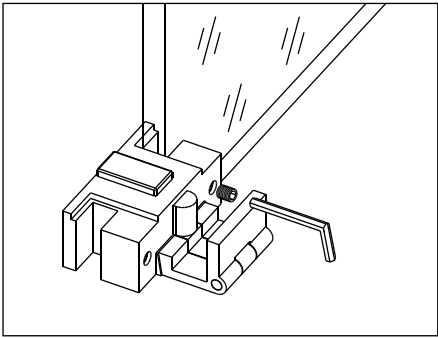
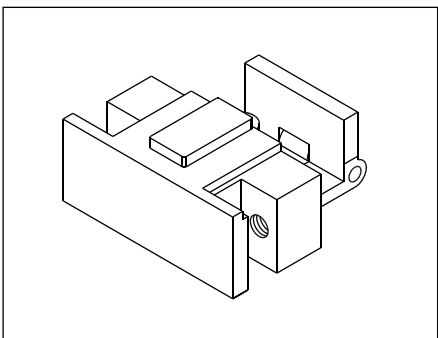
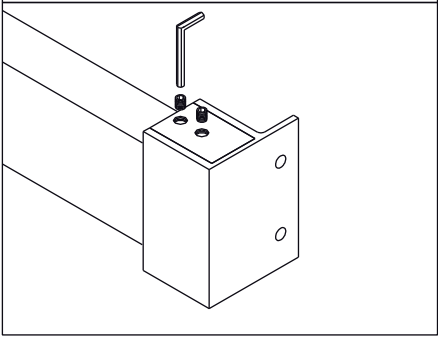
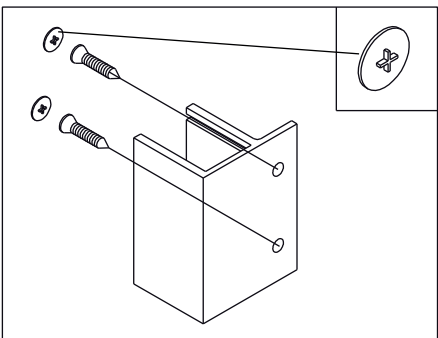

14

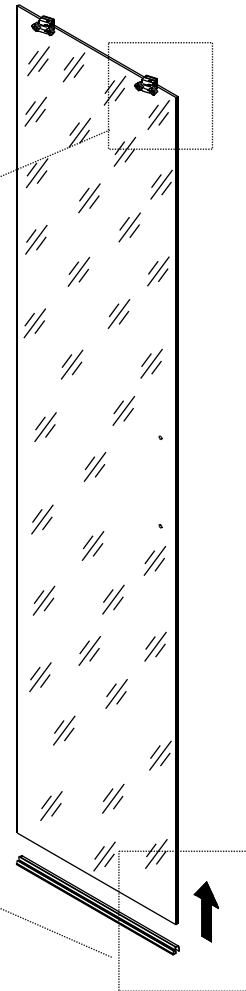
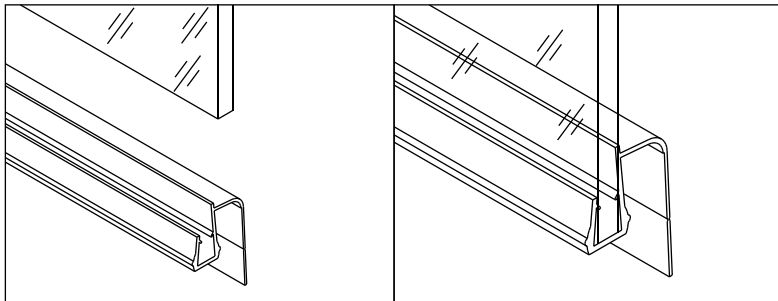
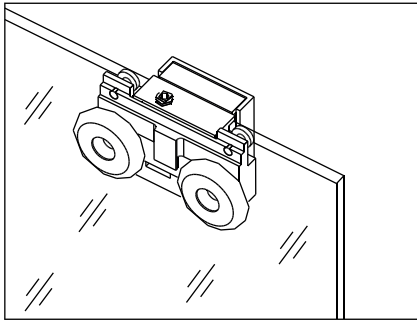
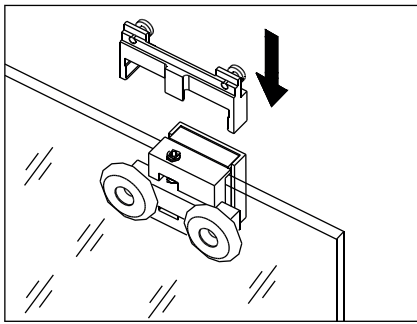

15

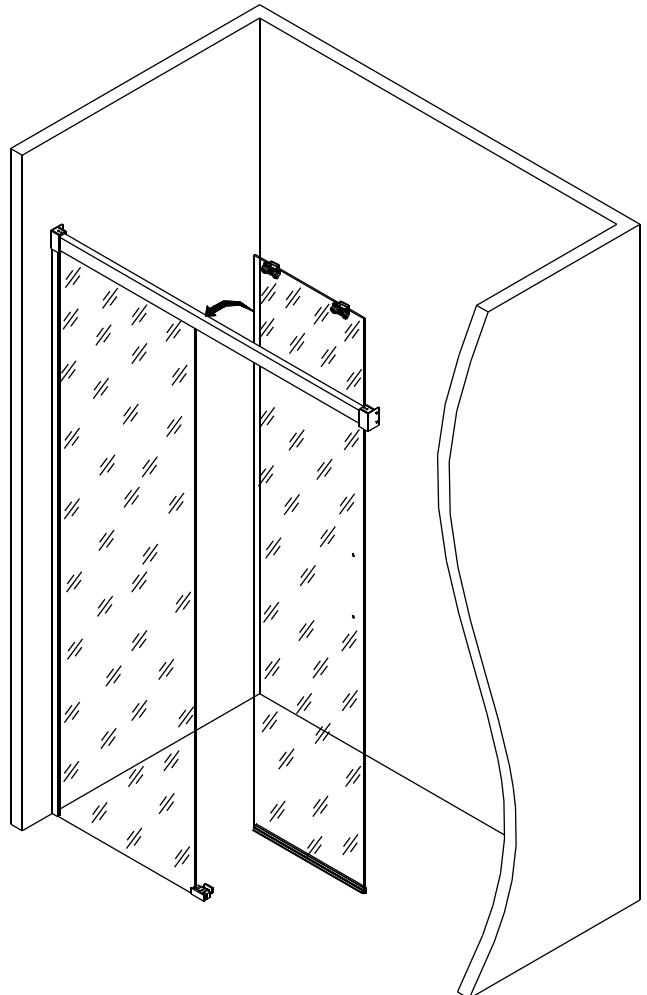
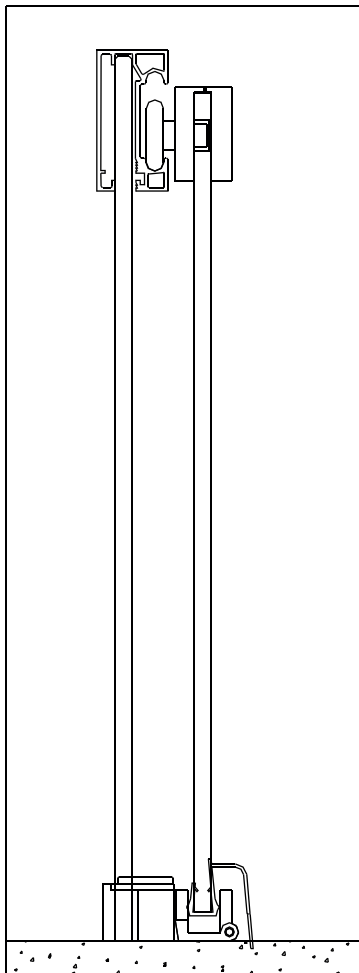

16

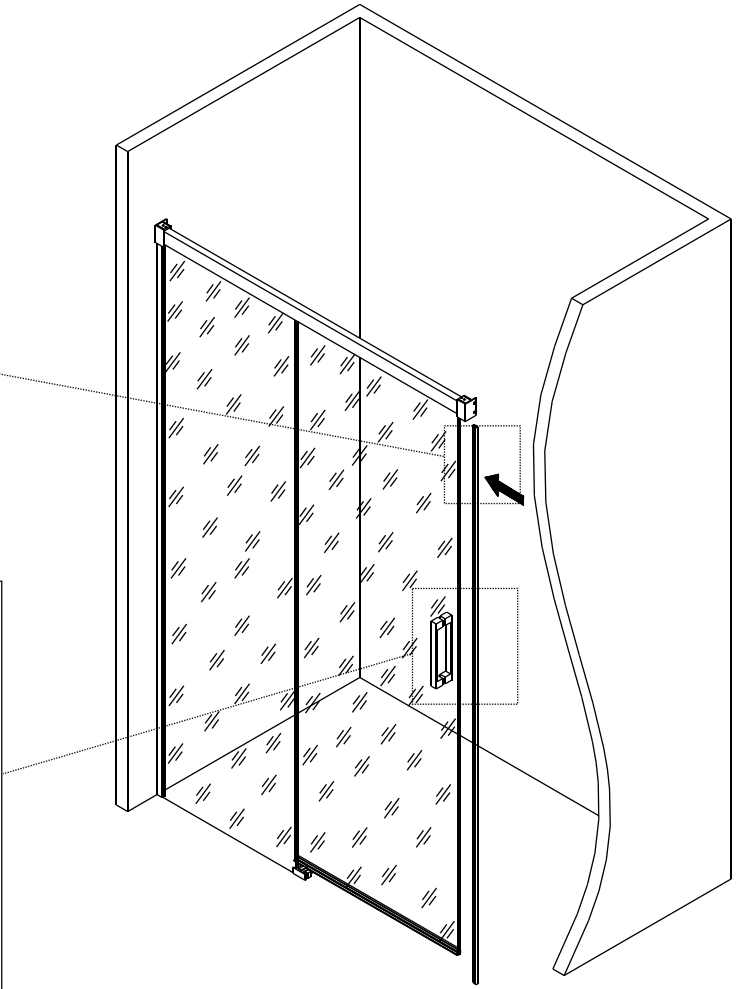
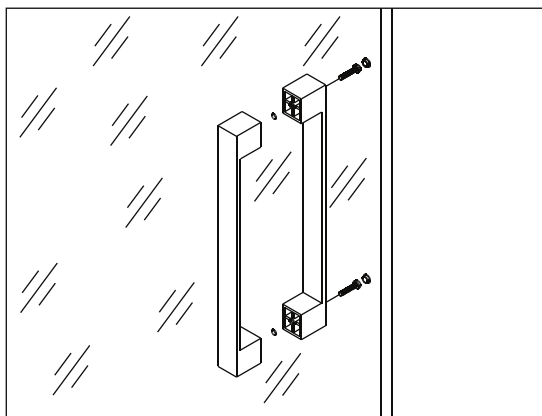
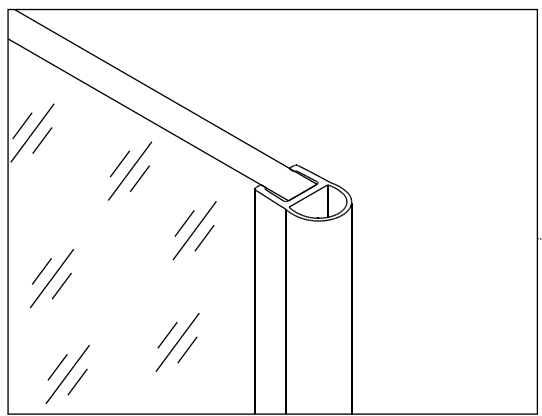

17

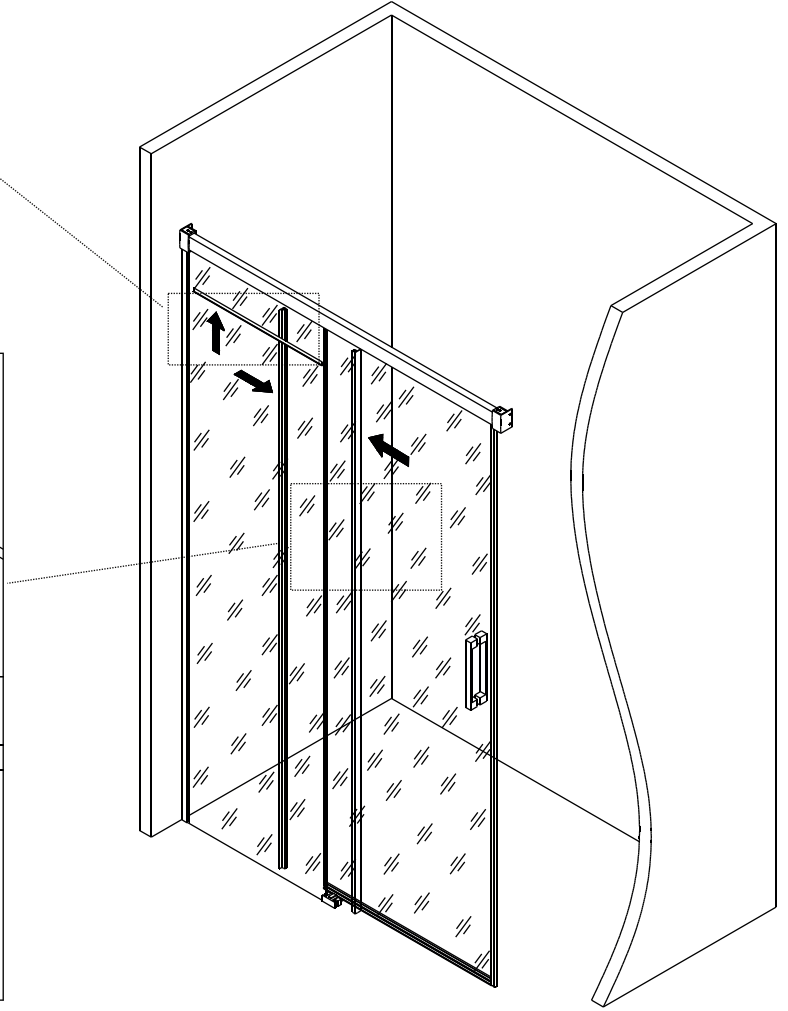
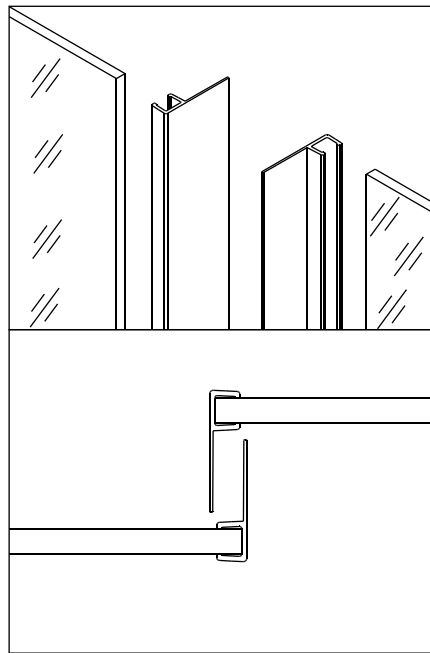
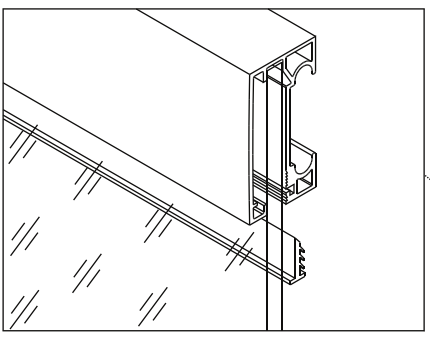

18

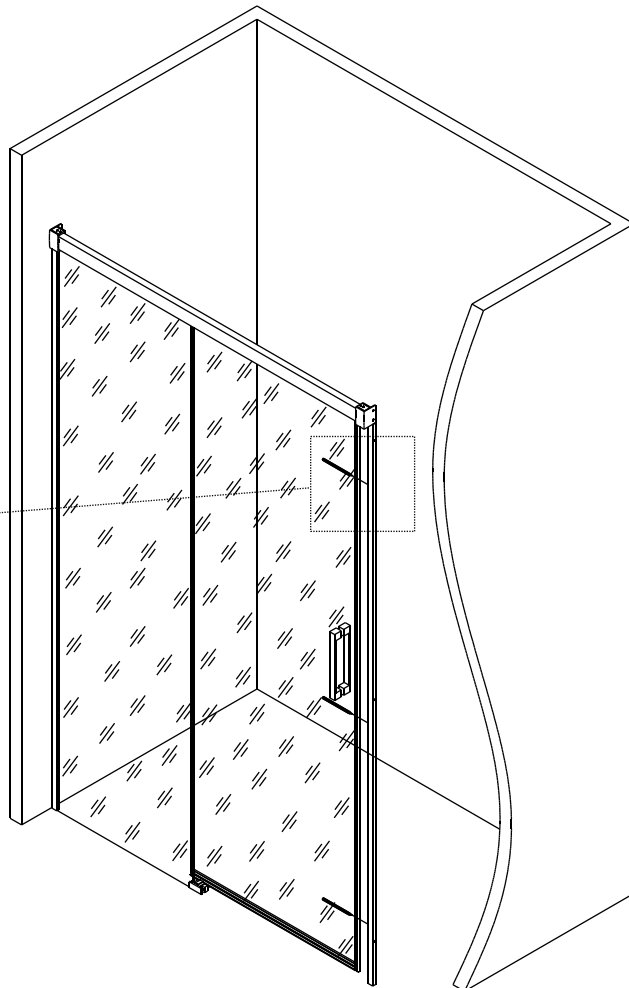
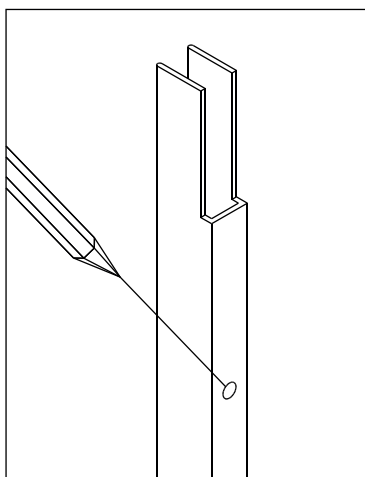
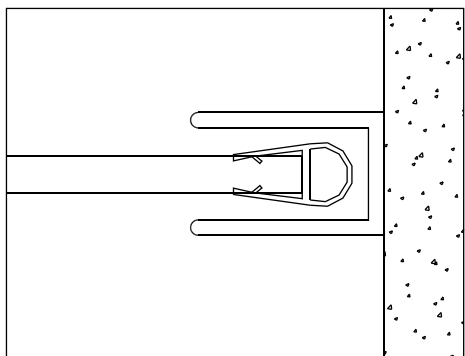

19

ST4*30

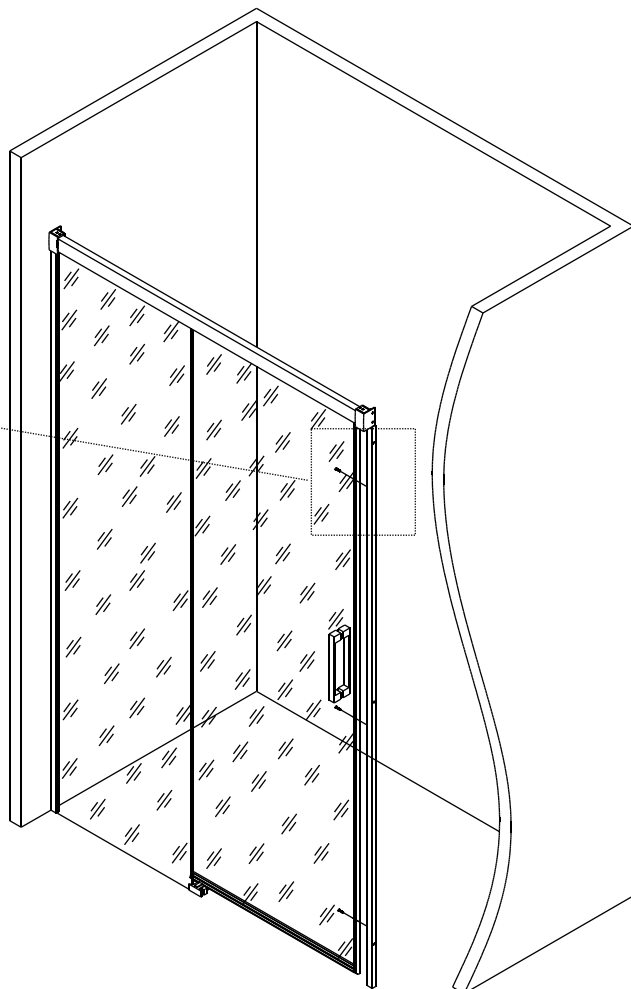
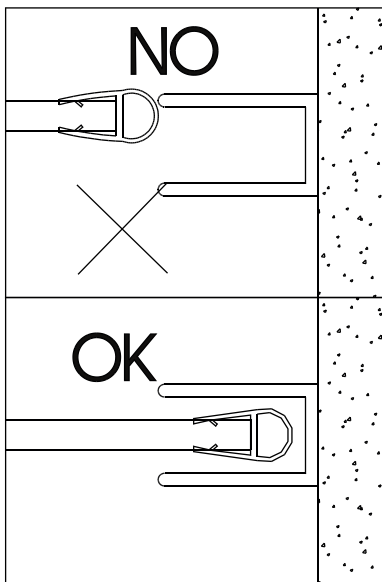
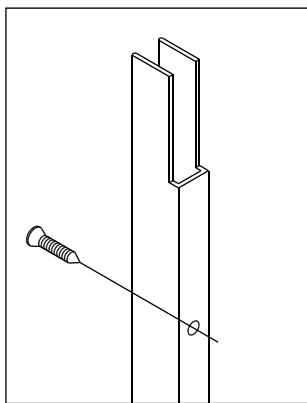

20

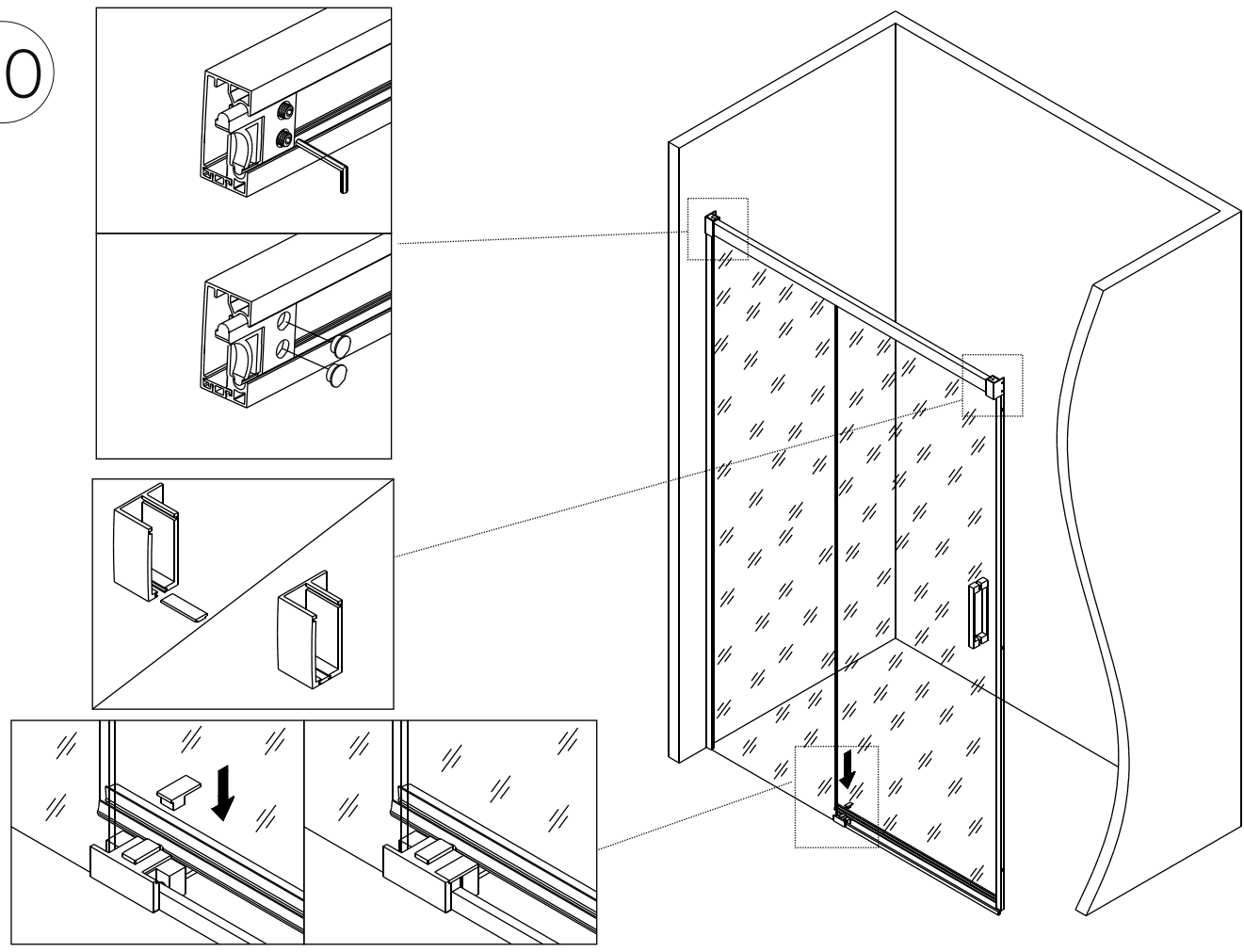

21

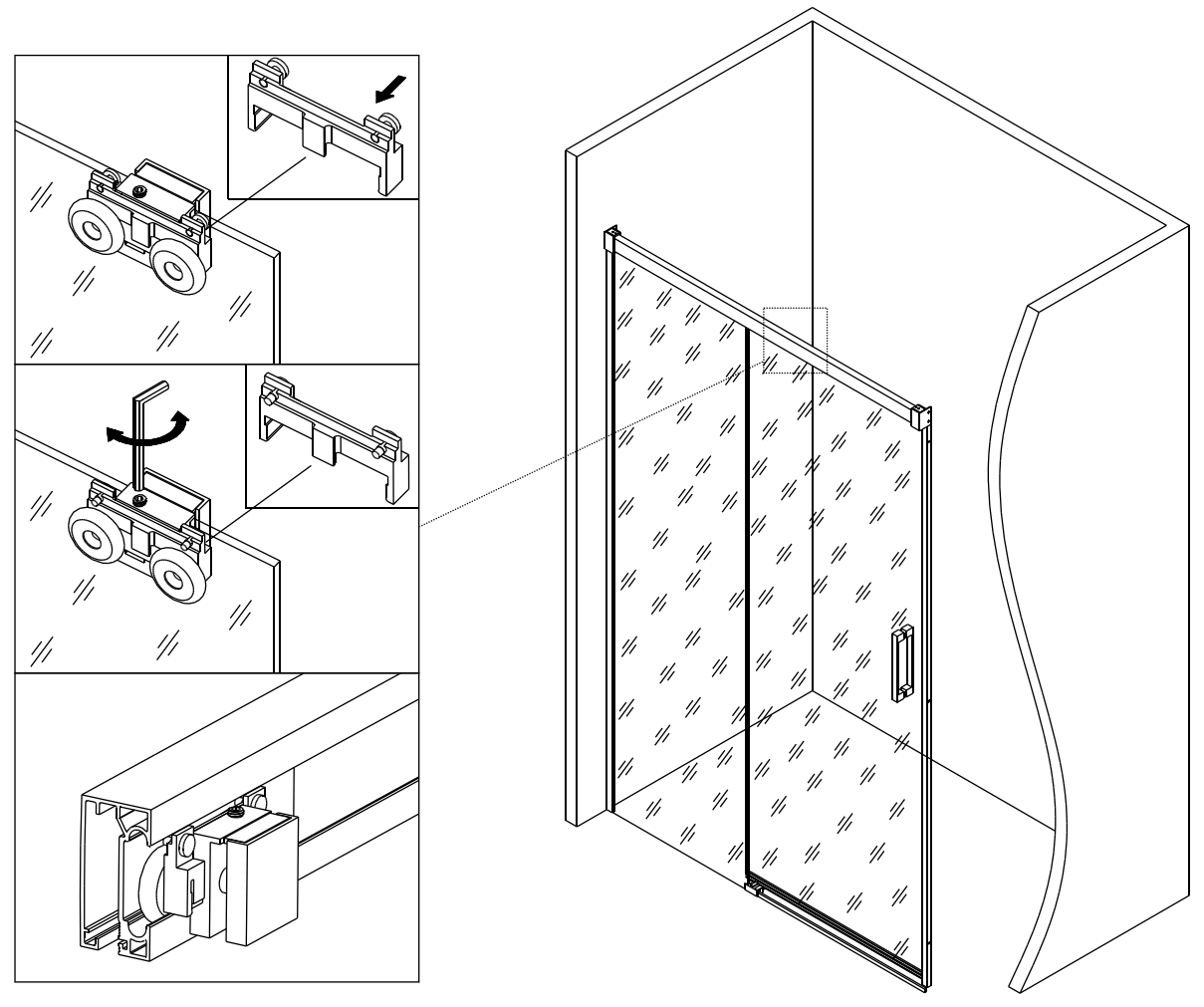

22

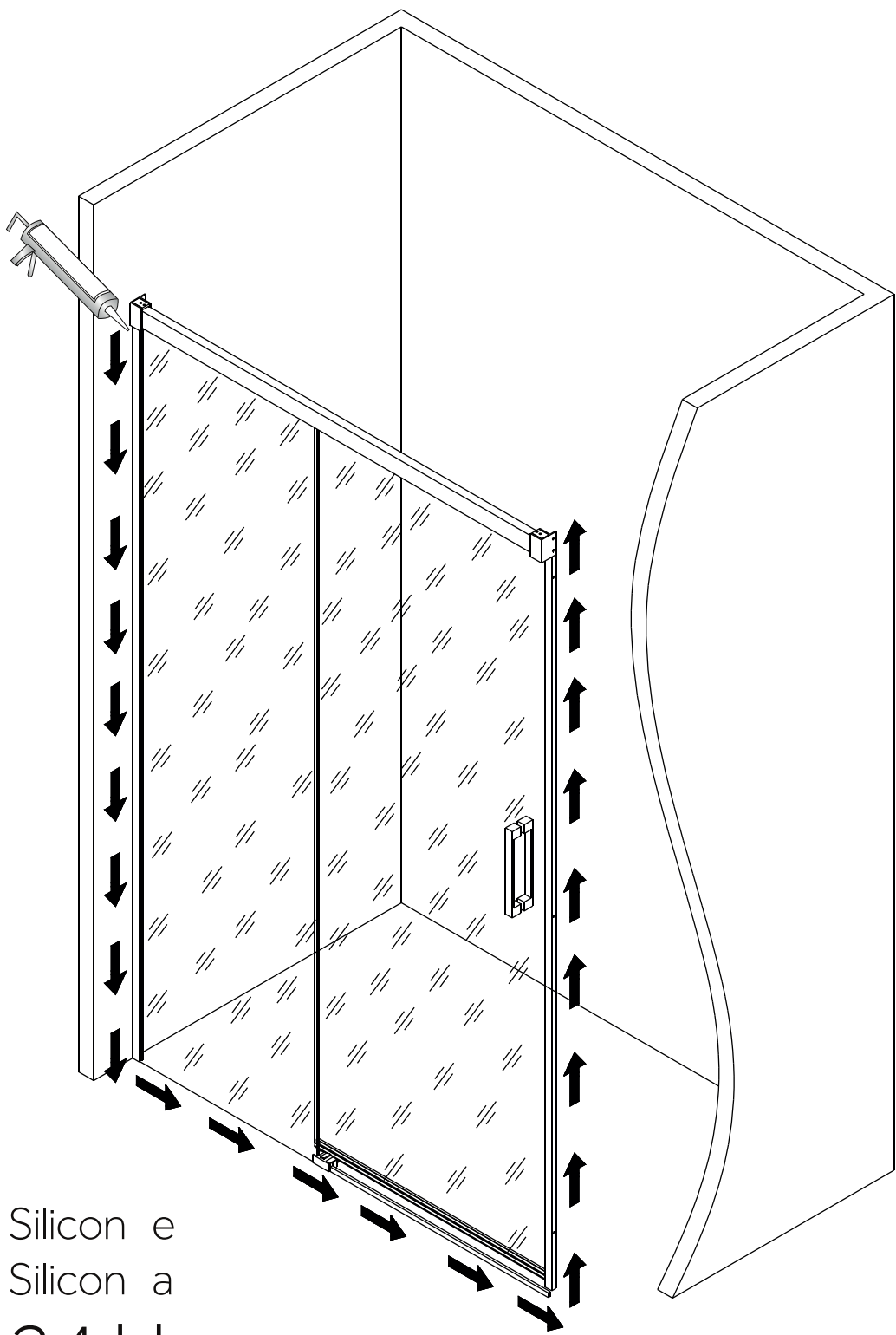

Silicon e
Silicon a
24 H

GME DIVISION BAÑOS S.L.
Avinguda Comarques del País Valencià, 197
46930 - Quart de Poblet
Valencia - España

telf. 00 34 96 252 18 55
fax 00349 252 18 56
info@gmelorente.com
www.gmelorente.com

GME
DIVISIÓN BAÑOS