

SAL

EN INSTALLATION INSTRUCTIONS
FR NOTICE DE MONTAGE
DE MONTAGEANLEITUNG
PT INSTRUÇÕES DE MONTAGEM
ES INSTRUCCIONES DE MONTAJE



EN READ THE SUPPLEMENTARY MANUALS.
FR LIRE LES NOTICES DE MONTAGE SUPPLÉMENTAIRES.
DE LESEN SIE DIE ZUSÄTZLICHEN MONTAGEANLEITUNGEN
PT CONSULTE OS MANUAIS COMPLEMENTARES.
ES LEA LOS MANUALES COMPLEMENTARIOS.



IIV797 | IIV1021

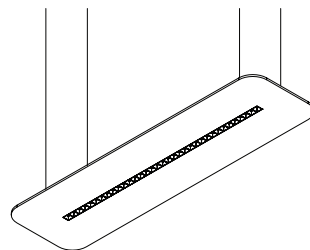

SAL M02 BOPTICS

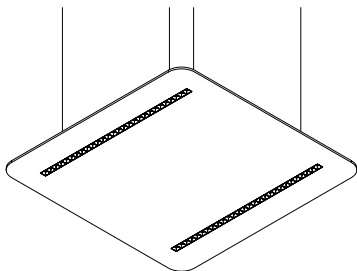

SAL M01 BOPTICS

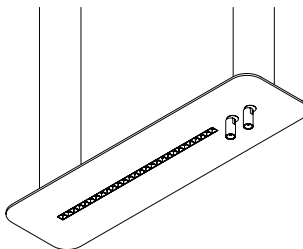

SAL M04 BOPTICS 2 SPOT

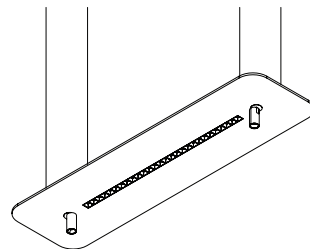

SAL M03 BOPTICS 2 SPOT

Order code / Code com. / Bestell-Nr. / Código / Código: 90973Q120...| 90973L140...| 90973L180...



IP20

650°C

230V/50Hz



EN Carefully read the installation instructions provided before installing the device. Safety and Maintenance: Scan here.
FR Lire attentivement les notices de montage avant l'installation de l'appareil. Sécurité et Entretien: Scannez ici.
DE Bitte lesen die mitgelieferte Montageanleitung vor der Montage des Geräts. Sicherheit und Wartung: Hier scannen.
PT Leia atentamente as instruções de montagem fornecidas antes de instalar o aparelho. Segurança e Manutenção: Scan aqui.
ES Lea atentamente las instrucciones de montaje proporcionadas antes de instalar el aparato. Seguridad y Mantenimiento: Escanea aquí.



SAL

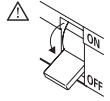

EN PANEL MANUFACTURED ACCORDING TO THE HIGHEST QUALITY STANDARDS, MAY VARY IN COLOUR AND THICKNESS DUE TO THE MIXTURE OF RECYCLED MATERIAL. THESE CHARACTERISTICS OF THE PRODUCT AREN'T COVERED BY WARRANTY SERVICES.

FR LES PANNEAUX FABRIQUÉS SELON LES NORMES DE QUALITÉ LES PLUS STRICTES PEUVENT PRÉSENTER DES VARIATIONS DE COULEUR ET D'ÉPAISSEUR DUES AU MÉLANGE DE MATÉRIAUX RECYCLÉS. CES CARACTÉRISTIQUES DU PRODUIT NE SONT PAS COUVERTES PAR LES SERVICES DE GARANTIE.

DE PANEEL, DAS NACH DEN HÖCHSTEN QUALITÄTSSTANDARDS HERGESTELLT WURDE, KANN FARB- UND DICKENABWEICHUNGEN AUFGRUND DER MISCHUNG VON RECYCELTEM MATERIAL AUFWEISEN. DIESE PRODUKTEIGENSCHAFTEN SIND NICHT DURCH GARANTIELEISTUNGEN ABGEDECKT.

PT PAINEL FABRICADO COM OS MAIS ALTOS PADRÕES DE QUALIDADE, PODE TER VARIAÇÕES DE COR E DE ESPESSURA CAUSADAS PELA MISTURA DE MATERIAL RECICLADO. ESTAS CARACTERÍSTICAS DO PRODUTO NÃO ESTÃO COBERTAS POR SERVIÇOS DE GARANTIA.

ES PANEL FABRICADO CON LOS MÁS ALTOS ESTÁNDARES DE CALIDAD, PUEDE VARIAR EN COLOR Y ESPESOR DEBIDO A LA MEZCLA DE MATERIAL RECICLADO. ESTAS CARACTERÍSTICAS DEL PRODUCTO NO ESTÁN CUBIERTAS POR LOS SERVICIOS DE GARANTIA.

TOOLS | OUTILS | WERKZEUG | FERRAMENTAS | HERRAMIENTAS

Phillips screwdriver



EN USE GLOVES.
FR UTILISEZ DES GANTS.
DE HANDSCHUHE BENUTZEN.
PT UTILIZE LUVAS.
ES USE GUANTES.



EN TO MARK THE HOLES ON THE CEILING, IT IS RECOMMENDED TO USE A LASER.

FR POUR MARQUER LES TROUS DANS LE PLAFOND, IL EST RECOMMANDÉ D'UTILISER UN LASER.

DE UM DIE LÖCHER AN DER DECKE ZU MARKIEREN, WIRD DIE VERWENDUNG EINES LASERS EMPFOHLEN.

PT PARA AS MARCAÇÕES DAS FURAÇÕES NO TETO RECOMENDA-SE O USO DE LASER.

ES PARA MARCAR LOS AGUJEROS EN EL TECHO, SE RECOMIENDA USAR UN LÁSER.

SAL		
⊠ (mm)	A	B
1200x1200	615	800
1400x500	200	1000
1800x500	300	1400

1200x1200

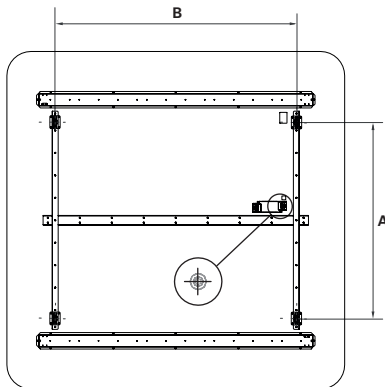

1400x500
1800x500

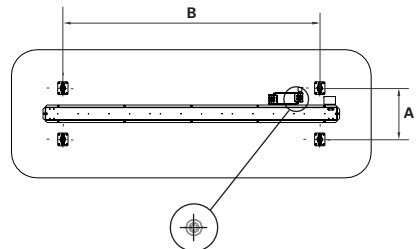

SAL

90973Q120... | 90973L140... | 90973L180...

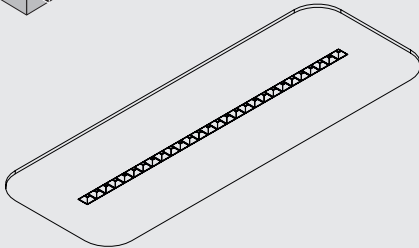

(x1)

S14 SUSPENSION SUSPENSION S14 SEILABHÄNGUNG S14 SUSPENSÃO S14 SUSPENSIÓN S14

+ 
IIV1021

91330...

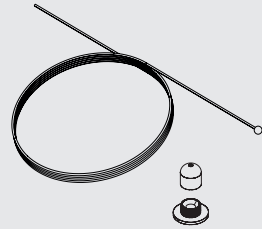

(x1)

CEILING ROSE PATÈRE DE SUSPENSION DECKENDOSE CAIXA DE ALIMENTAÇÃO BASE DE TETTO

978804

RECESSED CEILING ROSE T42 D50
PATÈRE DE SUSPENSION ENCASTRÉE T42 D50
DECKENDOSE ZUM EINBAU T42 D50
CAIXA DE ALIMENTAÇÃO ENCASTRADA T42 D50
BASE DE TETTO DE EMPOTRADA T42 D50



(x1)



(x2/x4)



(x1)



(x1)

978805

SURFACE MOUNTED CEILING ROSE T41 D50
PATÈRE DE SUSPENSION SAILLIE T41 D50
DECKENDOSE ZUM ANBAU T41 D50
CAIXA DE ALIMENTAÇÃO SALIENTE T41 D50
BASE DE TETTO DE SUPERFÍCIE T41 D50



(x2/x4)



(x1)



(x1)

+ 
IIV797

CURRENT SUPPLY CABLE CÂBLE D'ALIMENTATION EINSPEISUNGSKABEL CABO DE ALIMENTAÇÃO CABLE DE ALIMENTACIÓN

94040... | 94050...

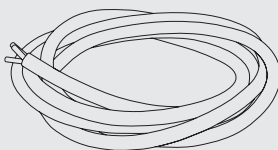

(x1)

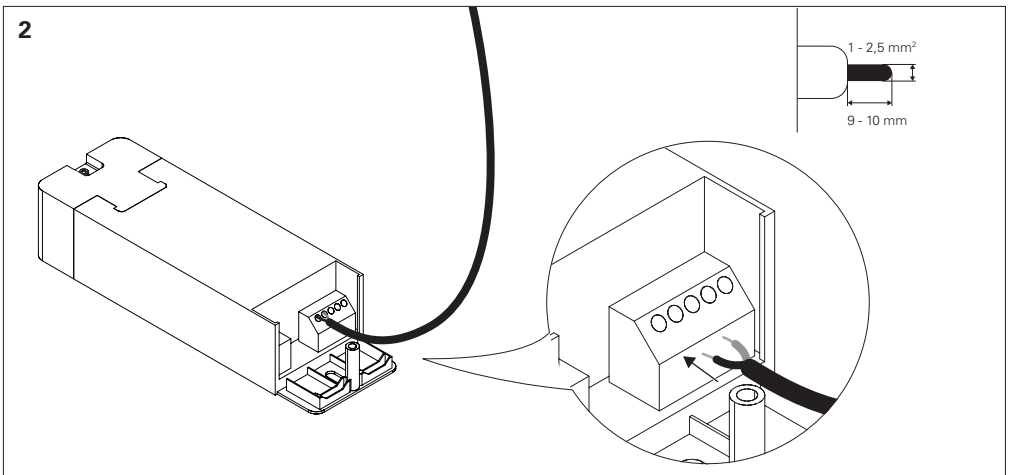
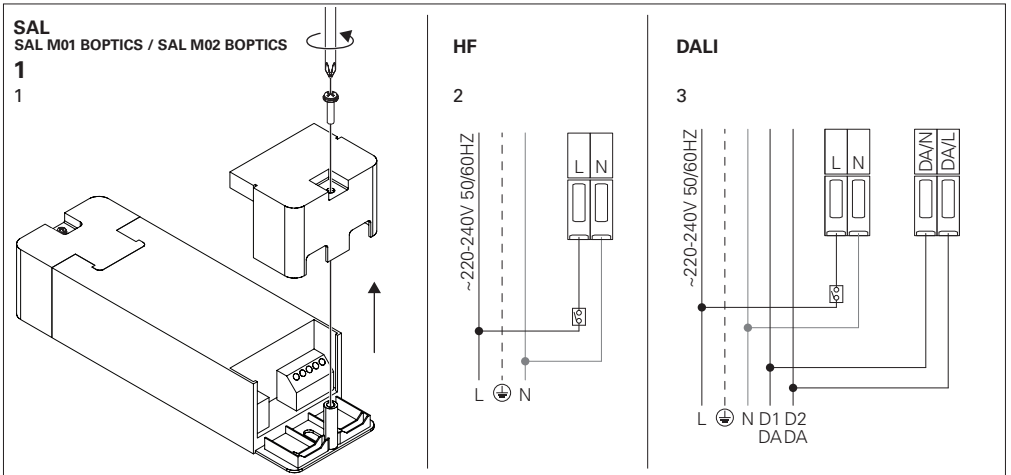
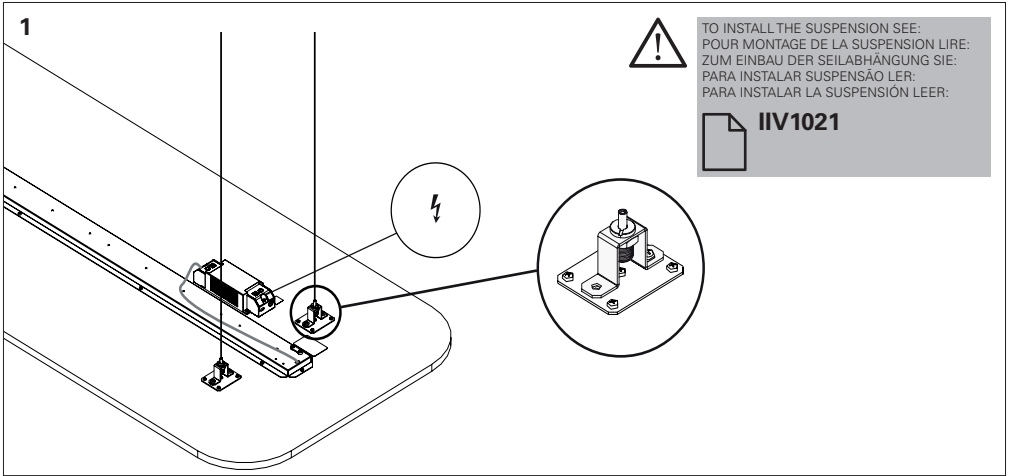

3

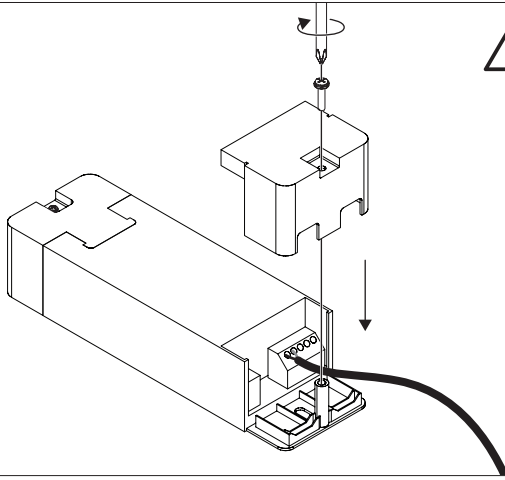

FOR MOUNTING THE CEILING ROSES READ:
POUR LE MONTAGE DES PATÈRE DE SUS-
PENSIONS LIRE:
FÜR DECKENDOSE, LESEN SIE:
PARA A MONTAGEM DAS CAIXAS DE
ALIMENTAÇÃO LER:
PARA MONTAR LAS BASES DE TECHO LEER:



IIV797

SAL + SPOTS

SAL M03 BOPTICS 2 SPOTS / SAL M04 BOPTICS 2 SPOTS

1

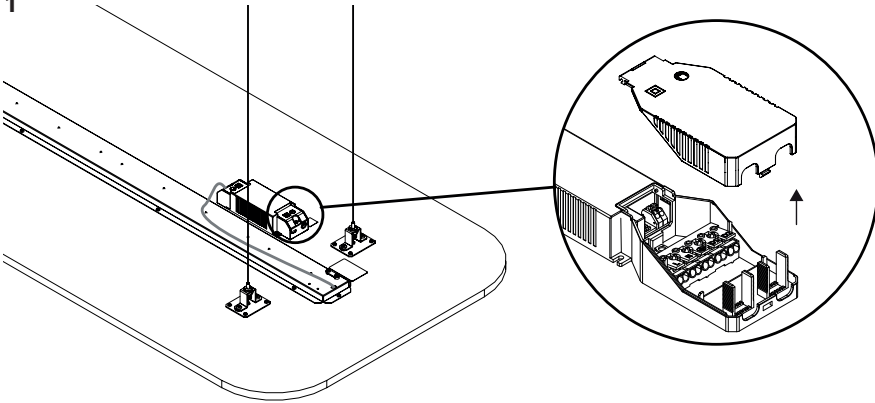

2

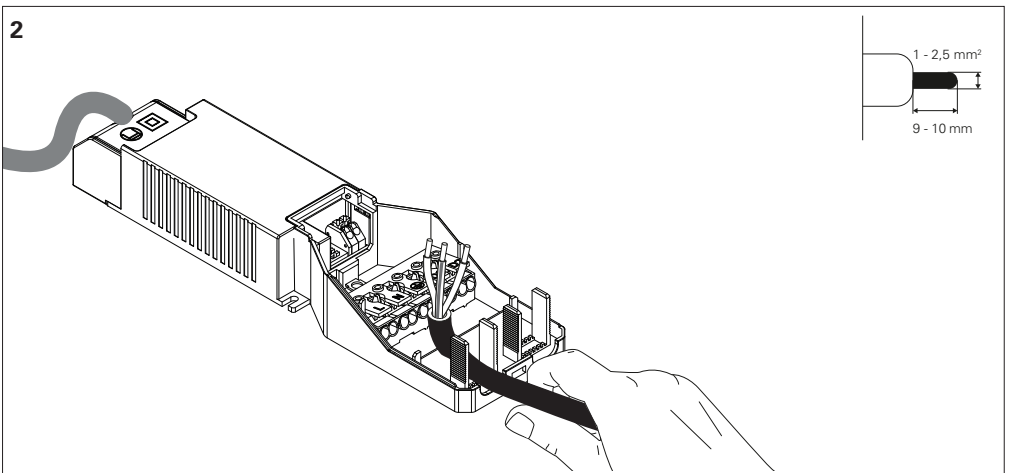

3
HF

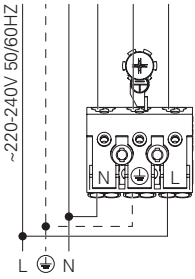

DALI



4

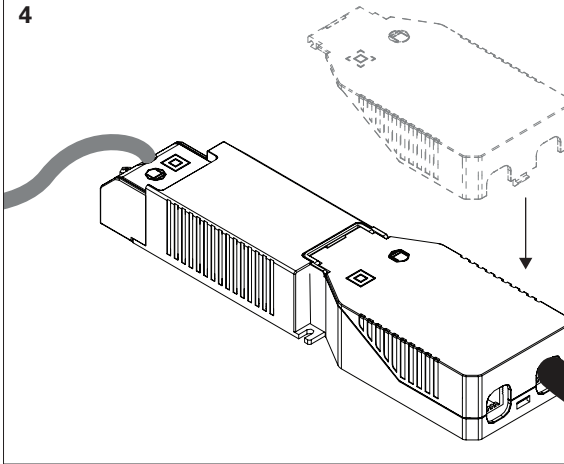

FOR MOUNTING THE CEILING ROSES READ:
POUR LE MONTAGE DES PATÈRE DE SUS-
PENSIONS LIRE:
FÜR DECKENDOSE, LESEN SIE:
PARA A MONTAGEM DAS CAIXAS DE
ALIMENTAÇÃO LER:
PARA MONTAR LAS BASES DE TECHO LEER:



IIV797