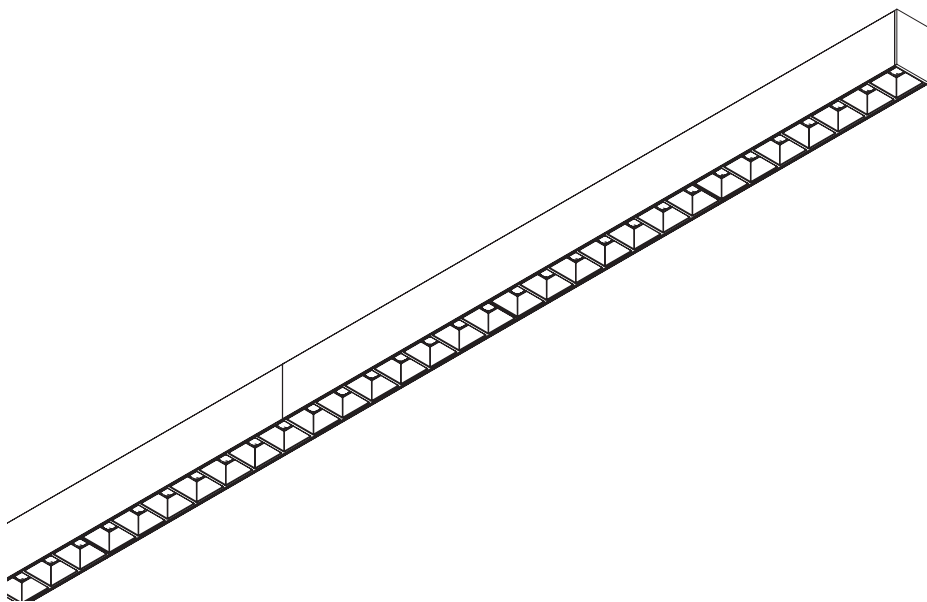
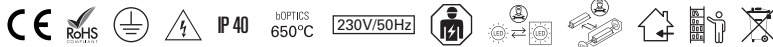

REBA 45 LITE /C Line

(SURFACE MOUNTED | SAILLIE | ANBAUVERSION | SALIENTE | SUPERFICIE)

EN INSTALLATION INSTRUCTIONS**FR** NOTICE DE MONTAGE**DE** MONTAGEANLEITUNG**PT** INSTRUÇÕES DE MONTAGEM**ES** INSTRUCCIONES DE MONTAJE

Order code / Code com. / Bestell-Nr. / Código / Código: 90980L... | 90981L...

**EN** Carefully read the installation instructions provided before installing the device. Safety and Maintenance: Scan here. |**FR** Lire attentivement les notices de montage avant l'installation de l'appareil. Sécurité et Entretien: Sancez ici. |**DE** Bitte lesen die mitgelieferte Montageanleitungen vor de Montage des Geräts. Sicherheit und Wartung: Hier scannen. |**PT** Leia atentamente as instruções de montagem fornecidas antes de instalar o aparelho. Segurança e Manutenção: Scan aqui. |**ES** Lea atentamente las instrucciones de montaje proporcionadas antes de instalar el aparato. Seguridad y Mantenimiento: Escanea aqui. |

REBA 45 LITE /C Line

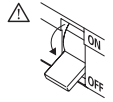

 (mm)
560x45x66
1120x45x66
1400x45x66
1680x45x66
2800x45x66

TOOLS | OUTILS | WERKZEUG | FERRAMENTAS | HERRAMIENTAS

Phillips screwdriver
Level ruler

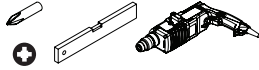

EN USE GLOVES.
FR UTILISEZ DES GANTS.
DE HANDSCHUHE BENUTZEN.
PT UTILIZE LUVAS.
ES USE GUANTES.

REBA 50 LITE /C LINE

90980L... | 90981L...

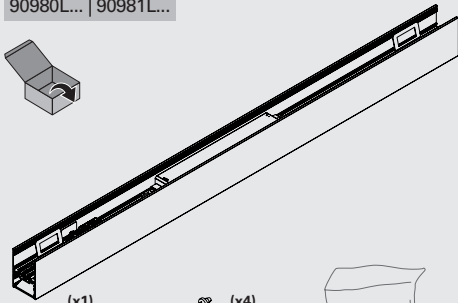

(x1)

 (x4)



(x2)

(x2)



(x2)

START KIT KIT DÉBUT DE LIGNE START KIT START KIT START KIT

924100

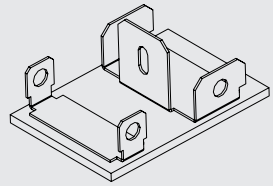

(x2)

(x2)

LINE (TOP VIEW)



EN Dimensions do not include start kit. To complete the line add 6 mm to the length.
FR Dimensions sans kit début de ligne. Veuillez ajouter 6 mm à la longueur pour compléter la ligne.
DE Abmessungen ohne Startkit. Fügen Sie der Länge 6 mm hinzu, um die Linie zu vervollständigen.
PT As dimensões não incluem start kit. Adicione 6 mm ao comprimento para completar a linha.
ES Las dimensiones no incluyen el star kit. Incremente 6 mm a la longitud para completar la línea.

| REBA 45 LITE / C Line | | | |
|-----------------------|-----|------|------|
| ⊠ (mm) | A | B | C |
| 560 | | 460 | |
| 1120 | 50 | 1020 | 22.5 |
| 1400 | | 1300 | |
| 1680 | | 790 | |
| 2800 | 175 | 1225 | |

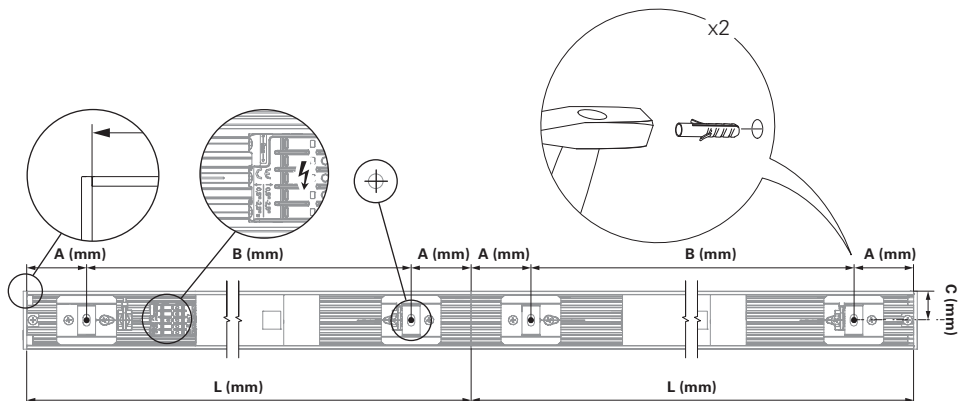

1680mm / 2800mm

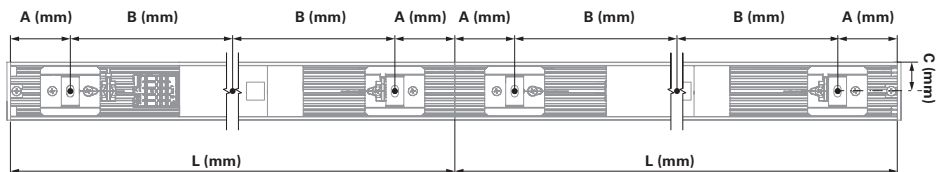

1 - (START/MIDDLE/END MODULE)

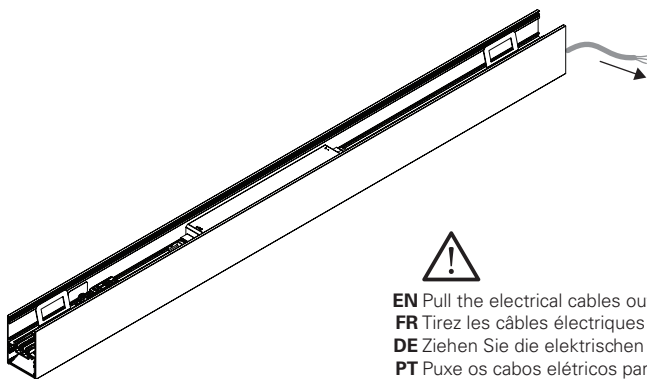

EN Pull the electrical cables out of the luminaire.
FR Tirez les câbles électriques hors du luminaire.
DE Ziehen Sie die elektrischen Kabel aus der Leuchte heraus.
PT Puxe os cabos elétricos para fora da luminária.
ES Saque los cables eléctricos de la luminaria.

2 - (START MODULE)

1.

x1

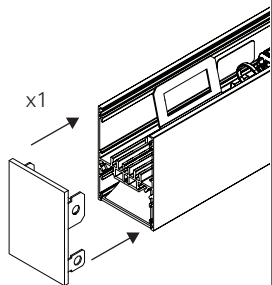

2.

x1

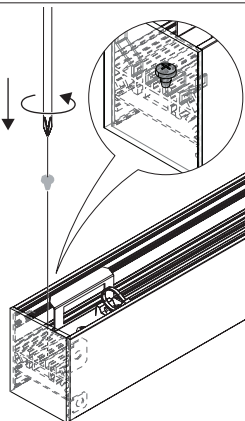

3.

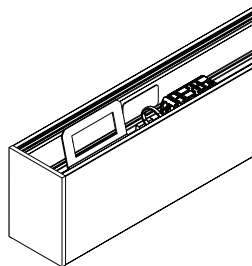

3 - (START MODULE)

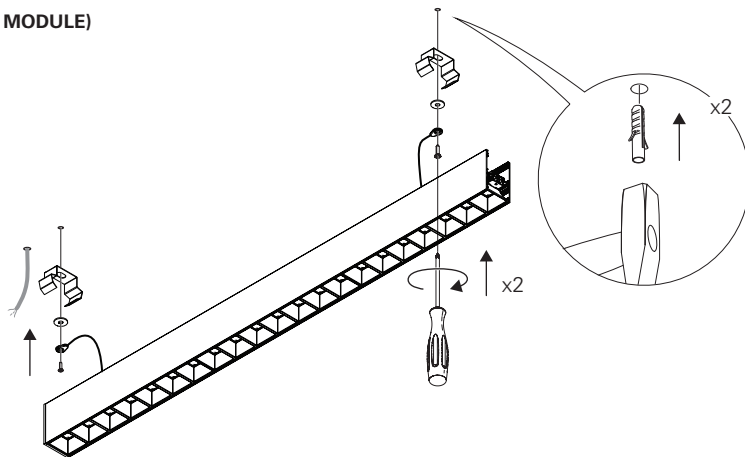

4 - (START MODULE)

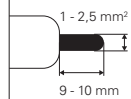
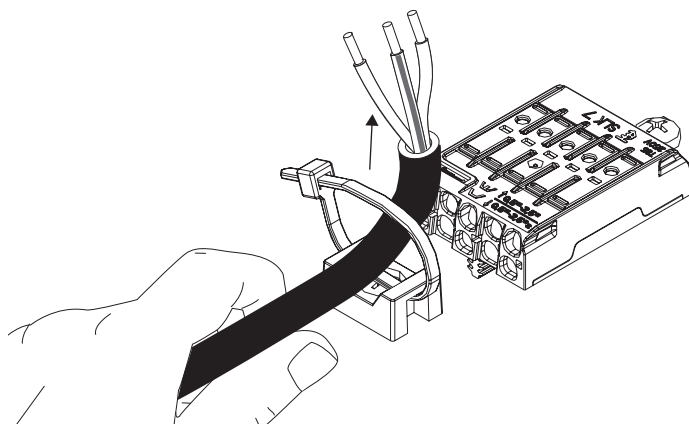

5 - HF (START MODULE)

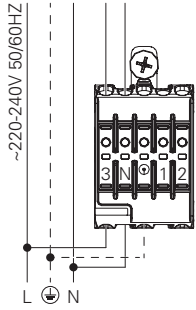

DALI (START MODULE)

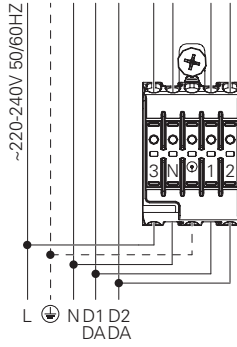

SWD (START MODULE)

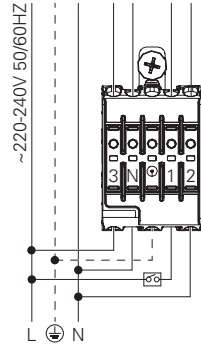

6 - (START MODULE)

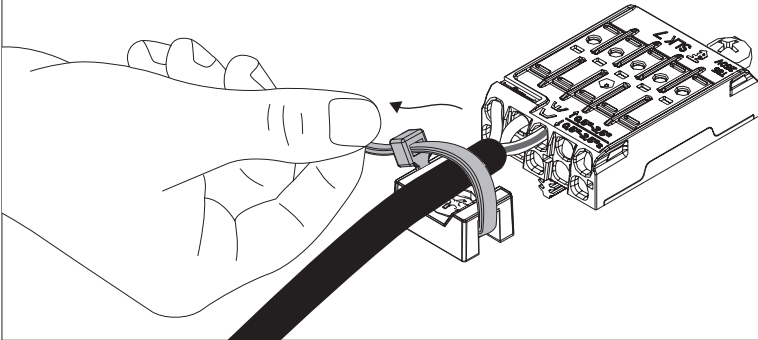

7 - (START MODULE)

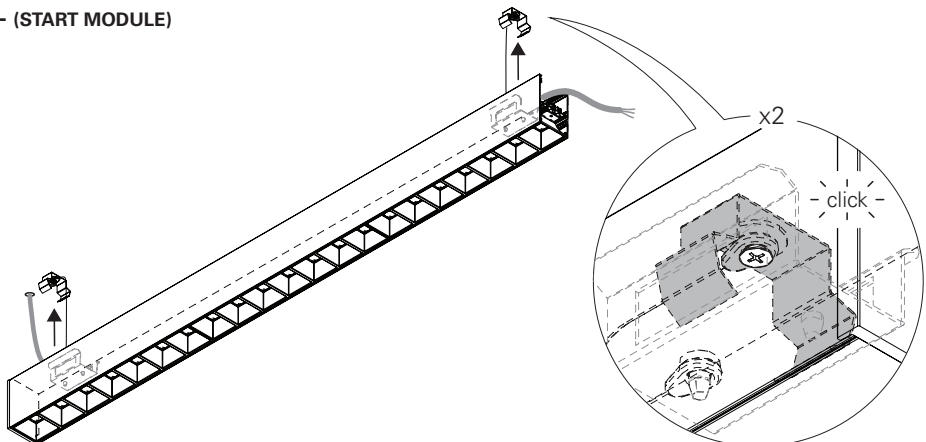

8 - (START MODULE)

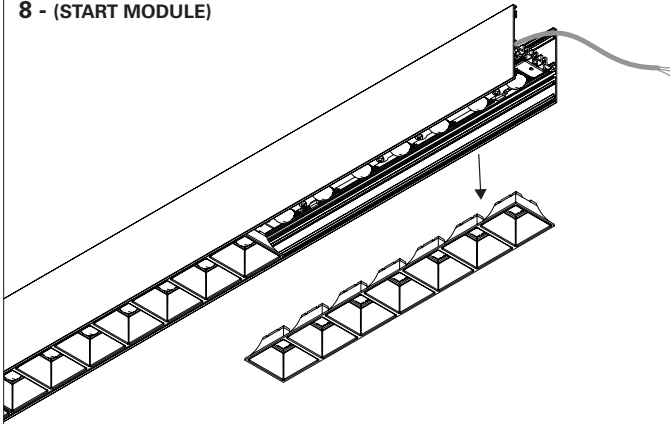

9 - (MIDDLE/END MODULE)

1.

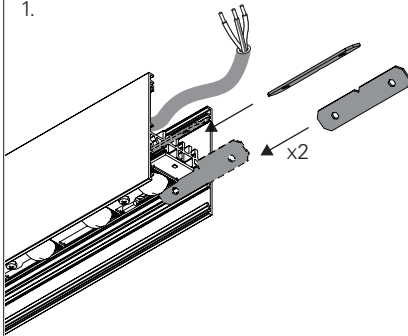

Front View

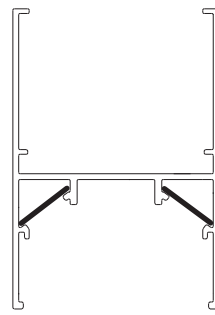

2.

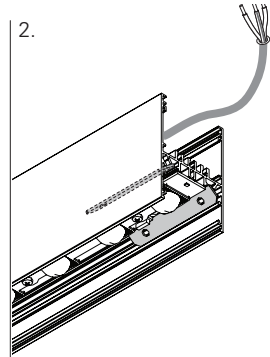

10 - (MIDDLE/END MODULE)

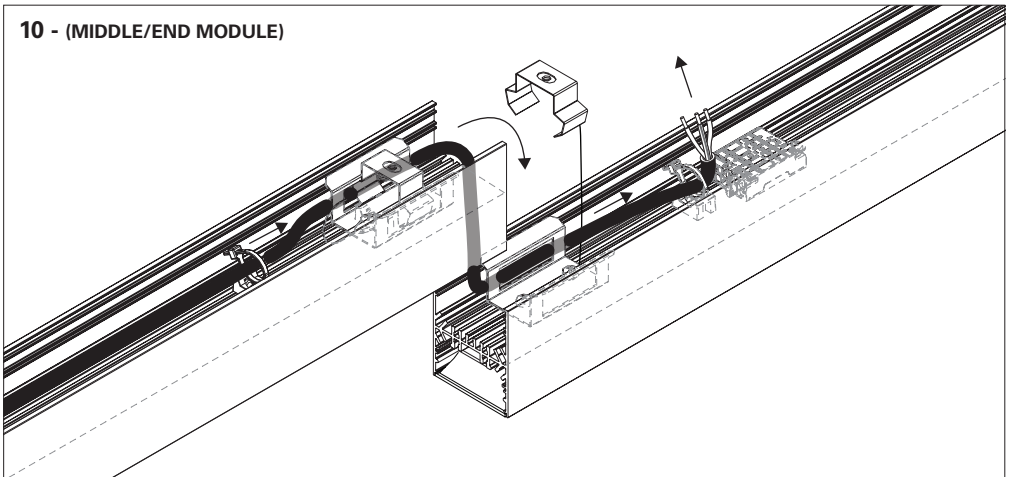

11 - (MIDDLE/END MODULE)

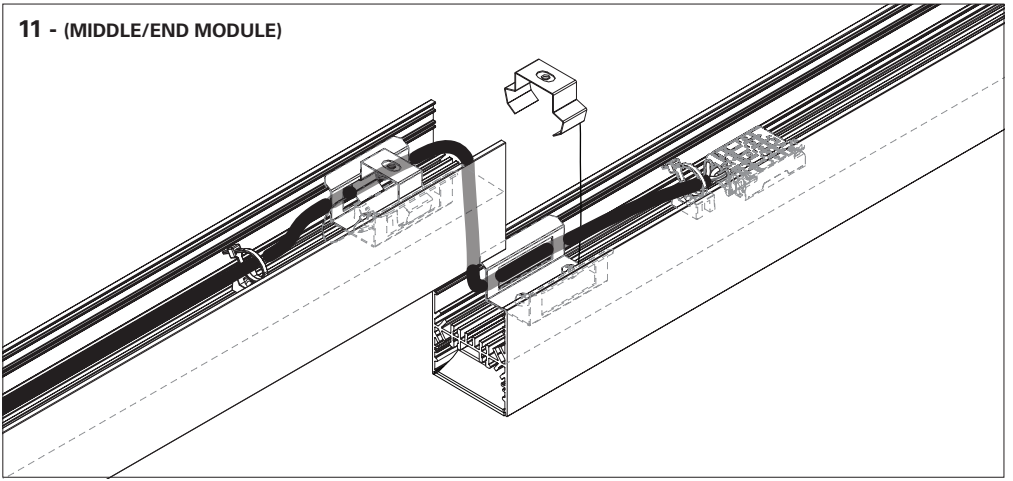

12 - HF (MIDDLE/END MODULE)

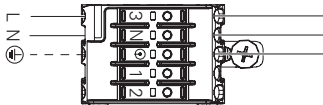

BLUE - N (NEUTRAL)
GREEN AND YELLOW - (EARTH)
BROWN - L (LIVE)

BLEU - N (NEUTRE)
VERT ET JAUNE - (TERRE)
MARRON - L (PHASE)

BLAU - N (NEUTRAL)
GRÜN UND GELB - (ERDE)
BRAUN - L (PHASE)

AZUL - N (NEUTRO)
VERDE E AMARELO - (TERRA)
CASTANHO - L (FASE)

AZUL - N (NEUTRAL)
VERDE Y AMARILLO - (TIERRA)
MARRÓN - L (FASE)

13 - DALI (MIDDLE/END MODULE)

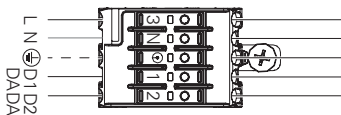

BLUE - N (NEUTRAL)
GREEN AND YELLOW - (EARTH)
BROWN - L (LIVE)
VIOLET - D1
ORANGE - D2

BLEU - N (NEUTRE)
VERT ET JAUNE - (TERRE)
MARRON - L (PHASE)
VIOLET - D1
ORANGE - D2

BLAU - N (NEUTRAL)
GRÜN UND GELB - (ERDE)
BRAUN - L (PHASE)
VIOLETT - D1
ORANGE - D2

AZUL - N (NEUTRO)
VERDE E AMARELO - (TERRA)
CASTANHO - L (FASE)
VIOLETA - D1
LARANJA - D2

AZUL - N (NEUTRAL)
VERDE Y AMARILLO - (TIERRA)
MARRÓN - L (FASE)
VIOLETA - D1
NARANJA - D2

14 - (MIDDLE/END MODULE)

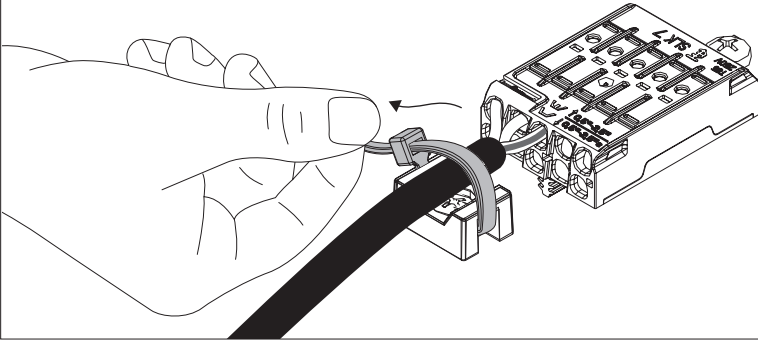

15 - (MIDDLE/END MODULE)

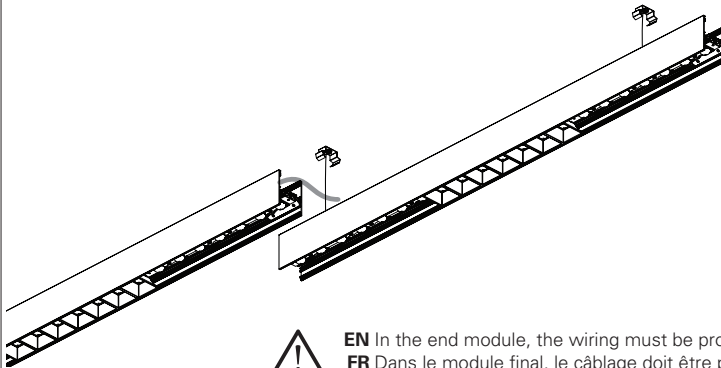

EN In the end module, the wiring must be protected or removed.

FR Dans le module final, le câblage doit être protégé ou retiré.

DE Im Endmodul muss die Verkabelung geschützt oder entfernt werden.

PT No módulo final, a fiação deve ser protegida ou removida.

ES En el módulo final, el cableado debe estar protegido o eliminado.

1.

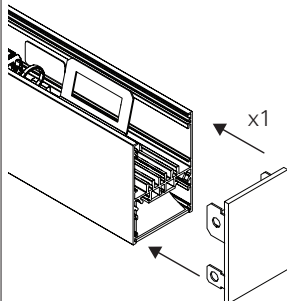

2.

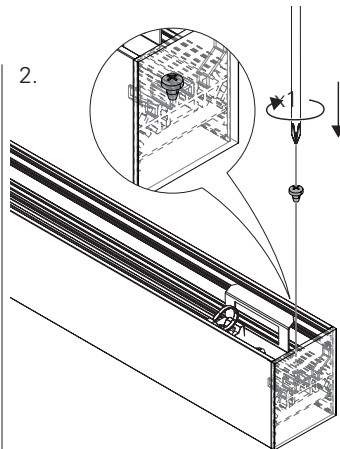

3.

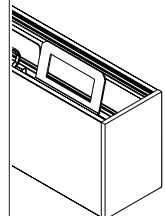

16 - (MIDDLE/END MODULE)

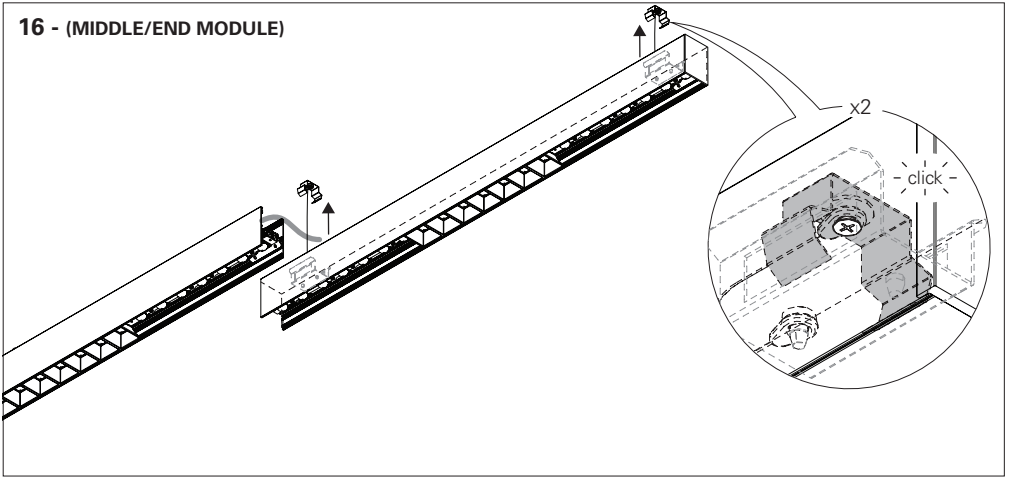

17 - (MIDDLE/END MODULE)

1.

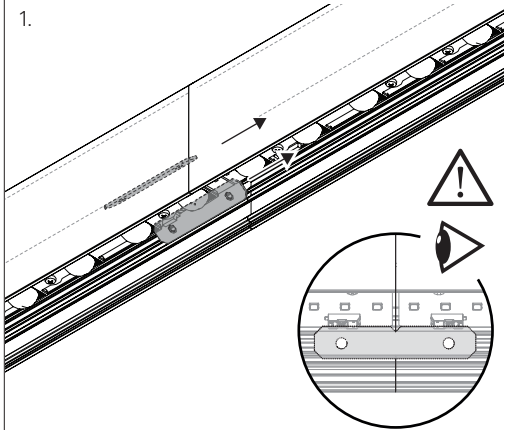

2.

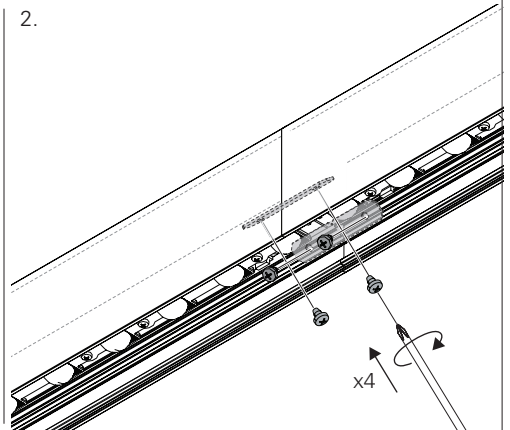

18

