

Ceiling rose T31 | Patère de suspension T31 | Deckendose T31 | Caixa de alimentação T31 | Base de techo T31

EN INSTALLATION INSTRUCTIONS
FR NOTICE DE MONTAGE
DE MONTAGEANLEITUNG
PT INSTRUÇÕES DE MONTAGEM
ES INSTRUCCIONES DE MONTAJE

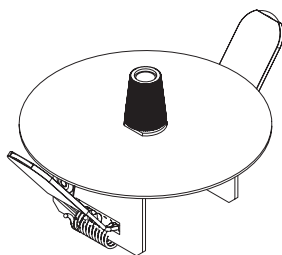

Order code / Code com. / Bestell-Nr. / Código / Código: 97275...



EN Carefully read the installation instructions provided before installing the device. Safety and Maintenance: Scan here.
FR Lire attentivement les notices de montage avant l'installation de l'appareil. Sécurité et Entretien: Scannez ici.
DE Bitte lesen die mitgelieferte Montageanleitungen vor de Montage des Geräts. Sicherheit und Wartung: Hier scannen.
PT Leia atentamente as instruções de montagem fornecidas antes de instalar o aparelho. Segurança e Manutenção: Scan aqui.
ES Lea atentamente las instrucciones de montaje proporcionadas antes de instalar el aparato. Seguridad y Mantenimiento: Escanea aquí.



EN CEILING ROSE
FR PATÈRE DE SUSPENSION
DE DECKENDOSE
PT CAIXA DE ALIMENTAÇÃO
ES BASE DE TECHO

T31

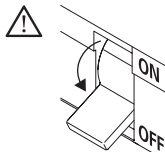
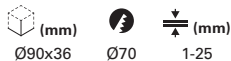

CEILING ROSE
PATÈRE DE SUSPENSION
DECKENDOSE
CAIXA DE ALIMENTAÇÃO
BASE DE TECHO

97275...

RECESSED CEILING ROSE T31 D90
 PATÈRE DE SUSPENSION ENCASTRÉE T31 D90
 DECKENDOSEN ZUM EINBAU T31 D90
 CAIXA DE ALIMENTAÇÃO ENCASTRAR T31 D90
 BASE DE TECHO DE EMPOTRAR T31 D90

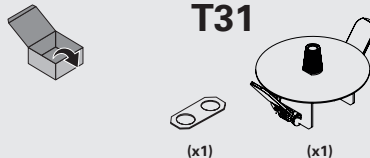

CURRENT SUPPLY CABLE
CÂBLE D'ALIMENTATION
EINSPEISUNGSKABEL
CABO DE ALIMENTAÇÃO
CABLE DE ALIMENTACIÓN

9402...|

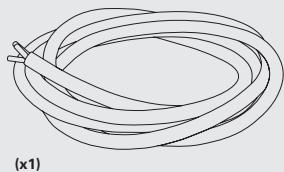

S13 SUSPENSION
SUSPENSION S13
SEILABHÄNGUNG S13
SUSPENSÃO S13
SUSPENSIÓN S13

9102...

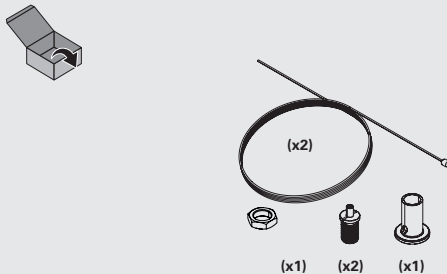

1

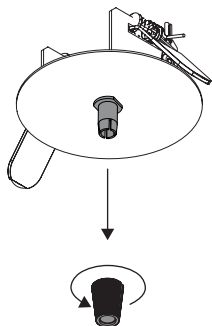

2

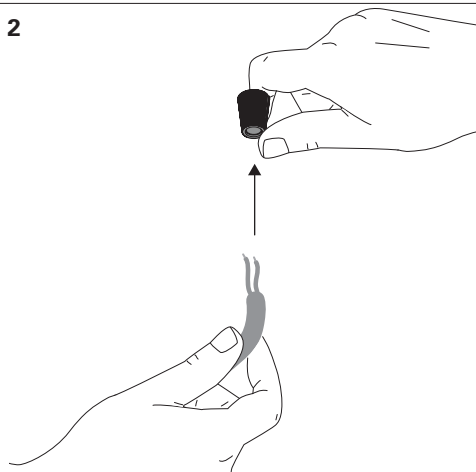

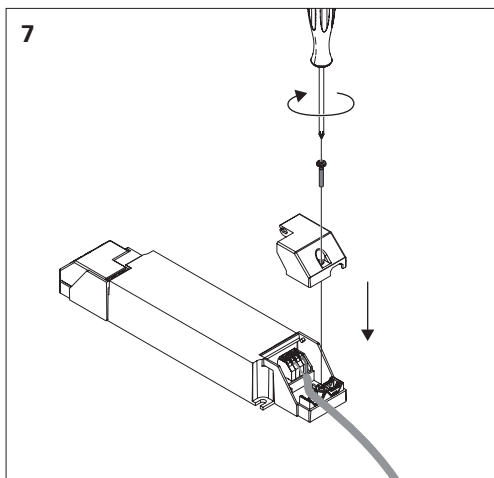
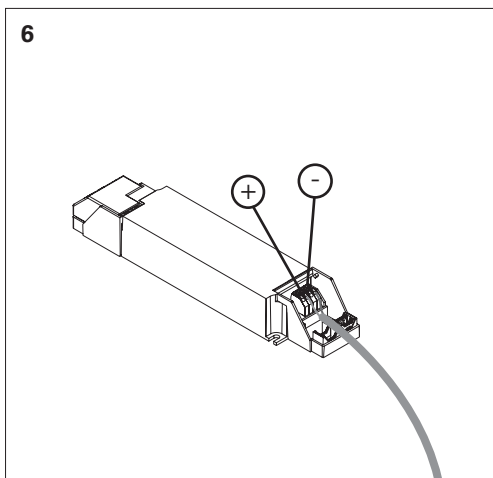
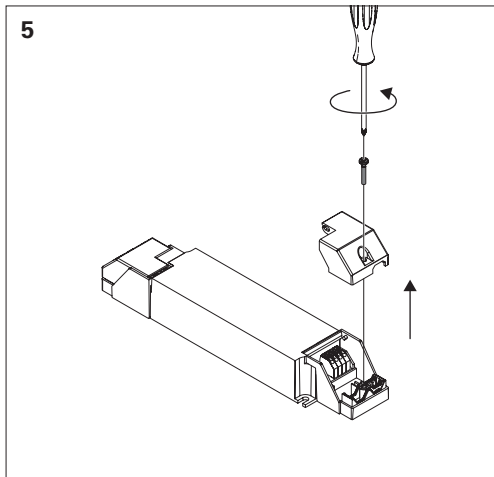
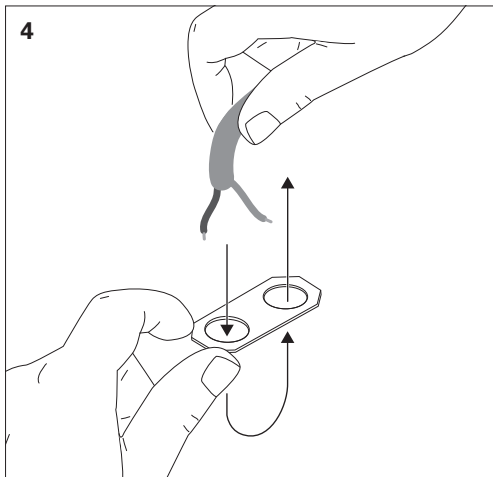
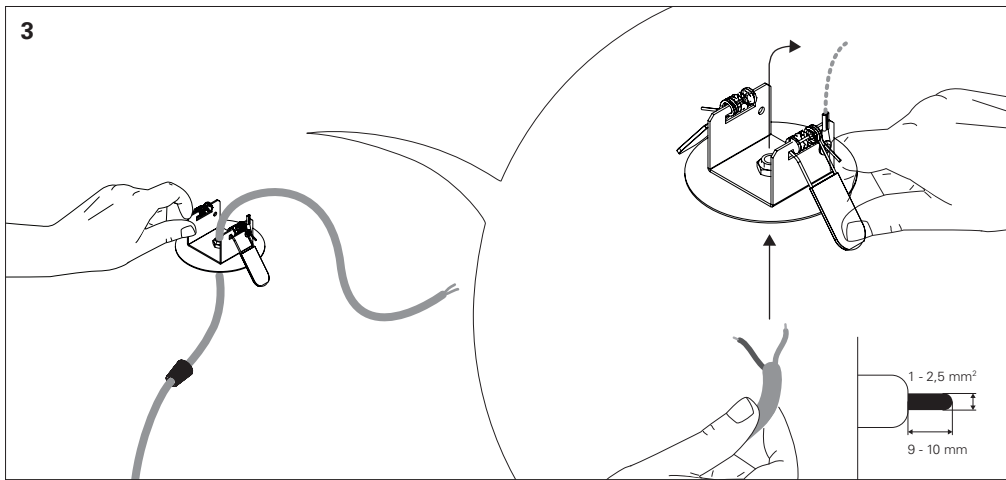

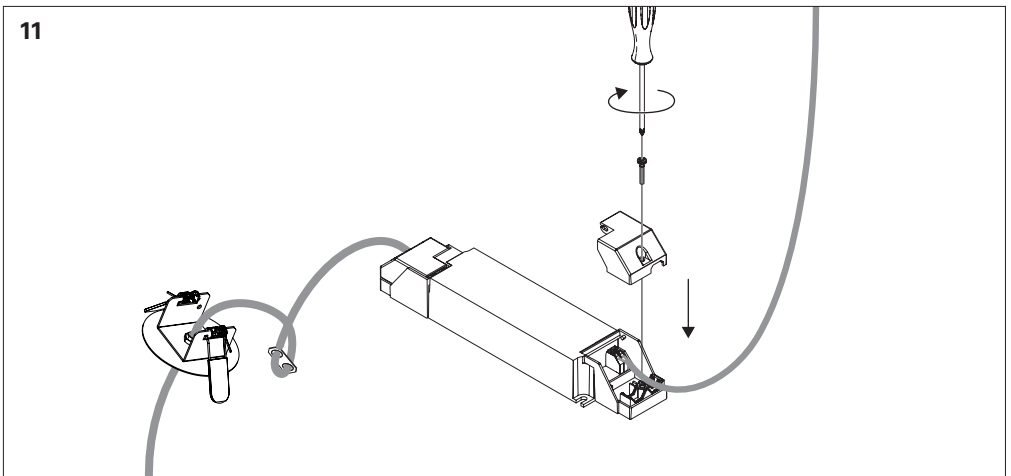
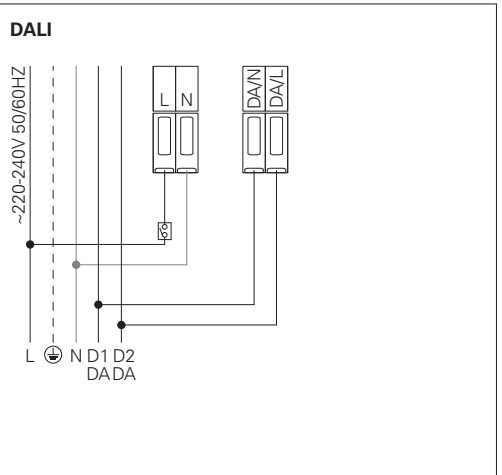
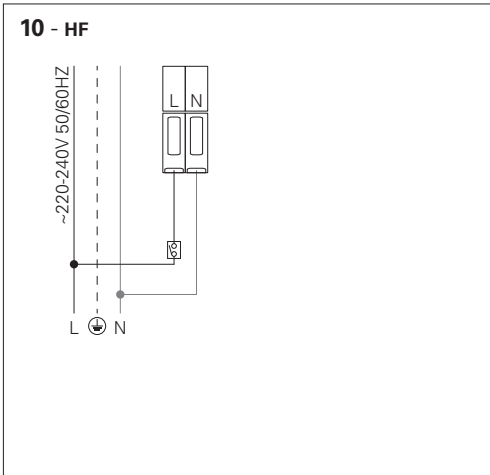
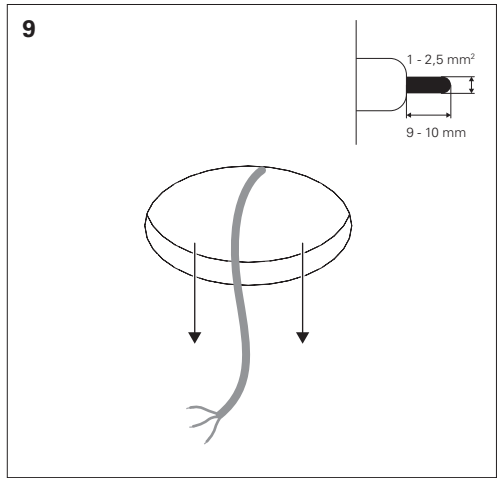
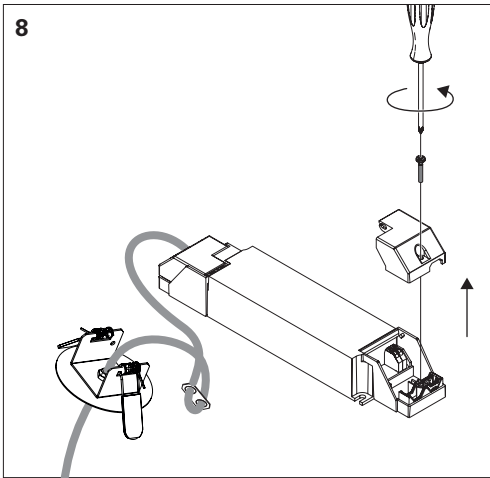

12

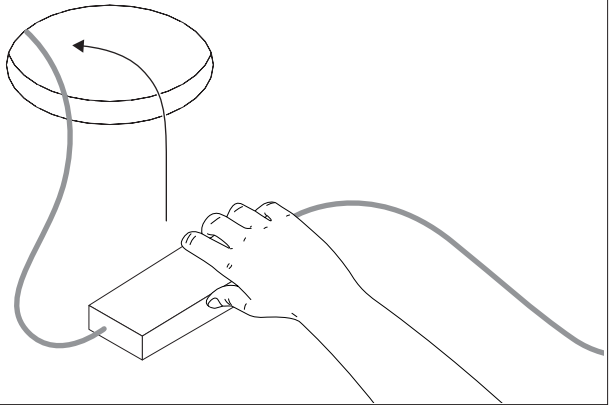

13

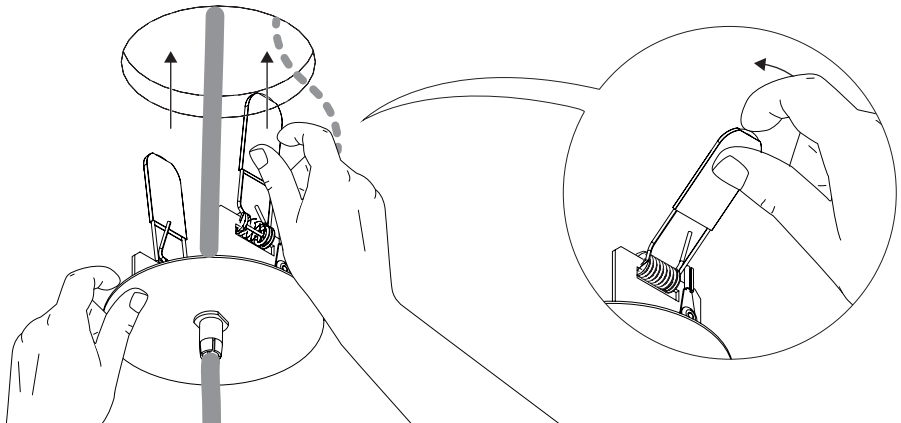

14

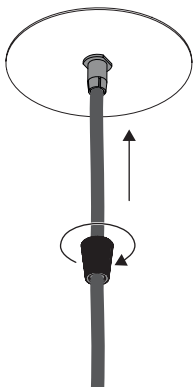

15



EN TO COMPLETE THE INSTALLATION READ THE COMPLEMENTARY MANUALS.
FR POUR FINIR L'INSTALLATION VOIR LES NOTICES COMPLÉMENTAIRES.
DE ZUR BEENDIGUNG DER VERSAMMLUNG ZUSÄTZLICHE ANLEITUNG LESEN.
PT PARA CONCLUIR A MONTAGEM LER MANUAIS COMPLEMENTARES.
ES PARA FINALIZAR EL MONTAJE LEER LOS MANUALES COMPLEMENTARIOS.