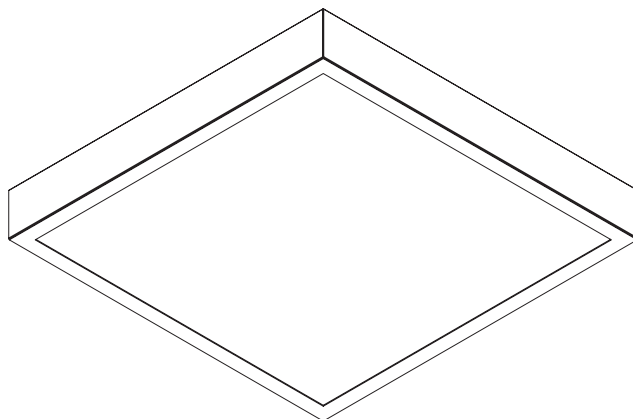

LNS IP

EN INSTALLATION INSTRUCTIONS**FR** NOTICE DE MONTAGE**DE** MONTAGEANLEITUNG**PT** INSTRUÇÕES DE MONTAGEM**ES** INSTRUCCIONES DE MONTAJE

Order code / Code com. / Bestell-Nr. / Código / Código: 90809L... |90810L...

**EN** Carefully read the installation instructions provided before installing the device. Safety and Maintenance: Scan here.**FR** Lire attentivement les notices de montage avant l'installation de l'appareil. Sécurité et Entretien: Sancez ici.**DE** Bitte lesen die mitgelieferte Montageanleitungen vor de Montage des Geräts. Sicherheit und Wartung: Hier scannen.**PT** Leia atentamente as instruções de montagem fornecidas antes de instalar o aparelho. Segurança e Manutenção: Scan aqui.**ES** Lea atentamente las instrucciones de montaje proporcionadas antes de instalar el aparato. Seguridad y Mantenimiento: Escanea aqui.

LNS IP



(mm)
597x597x80
1149x320x80
1425x320x80

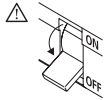

TOOLS | OUTILS | WERKZEUG | FERRAMENTAS | HERRAMIENTAS

Phillips screwdriver



EN USE GLOVES.
FR UTILISEZ DES GANTS.
DE HANDSCHUHE BENUTZEN.
PT UTILIZE LUVAS.
ES USE GUANTES.



LNS IP

90809L... | 90810L...

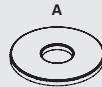
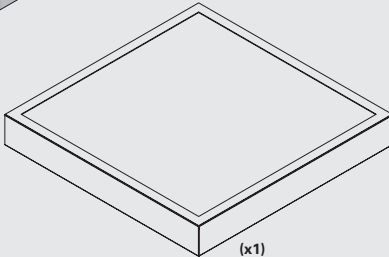
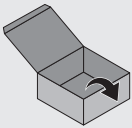

A Steel washer DIN 9021 M5
Rondelle en tôle DIN 9021M5
Unterlegscheiben aus Blech DIN 9021 M5
Anilha em chapa DIN 9021 M5
Arandela en chapa DIN 9021 M5



B Rubber washer
Rondelle en caoutchouc
Unterlegscheiben aus Gummi
Anilha de Borracha
Arandela en goma

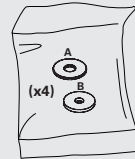

LNS IP

(mm)	A	B	C	D
1149x320x90	1042	220	45	160
1425x320x90	1318	220	45	160
597x597x90	490	450		299

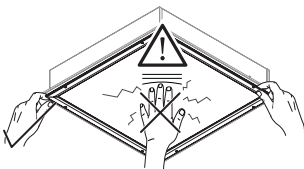

EN DO NOT PRESS – RISK OF BREAKAGE.
FR NICHT DRÜCKEN – BRUCHGEFAHR.
DE NE PAS APPUYER – RISQUE DE CASSE.
PT NÃO PRESSIONE – RISCO DE QUEBRA.
ES NO PRESIONAR – RIESGO DE ROTURA.

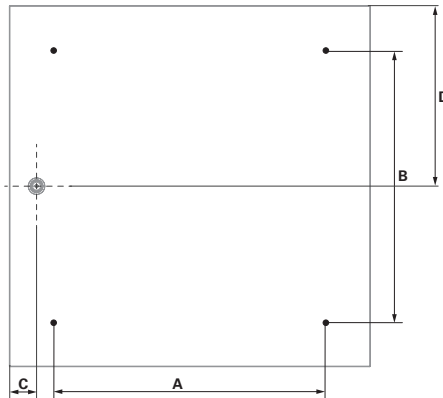

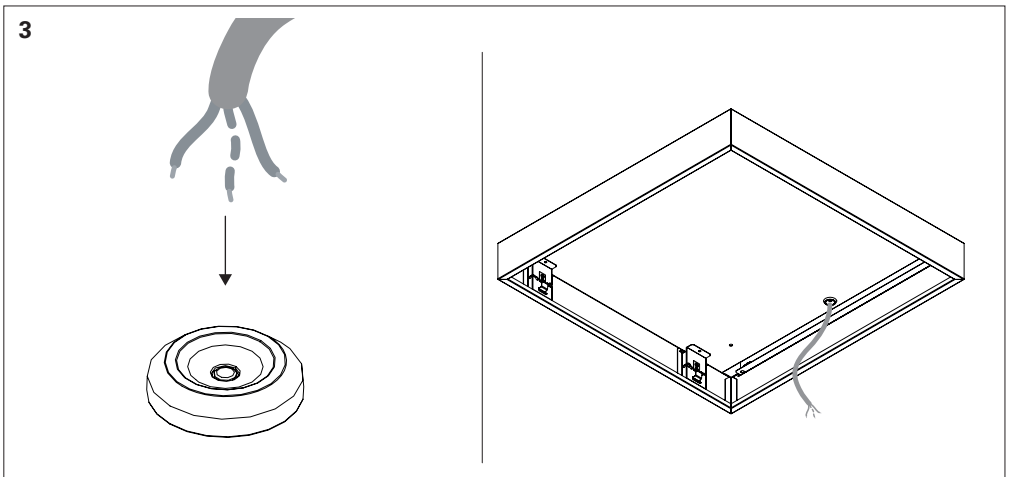
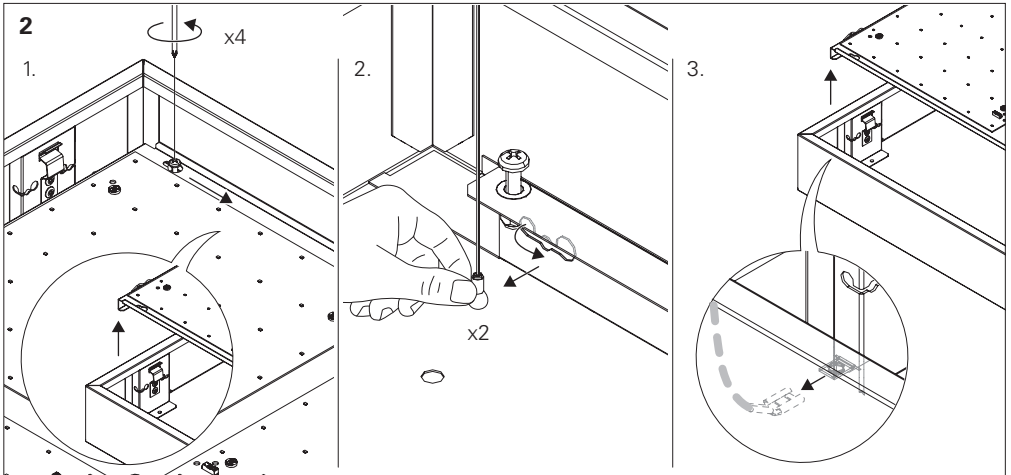
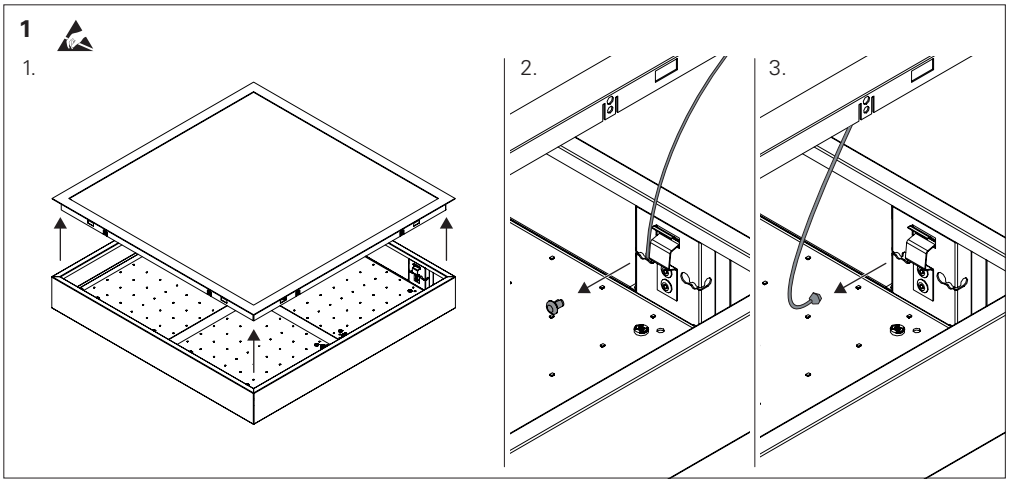

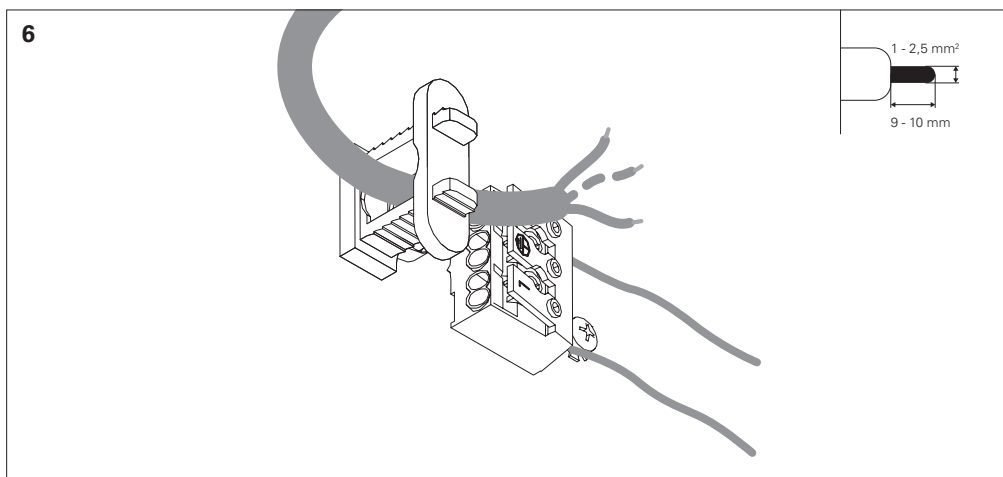
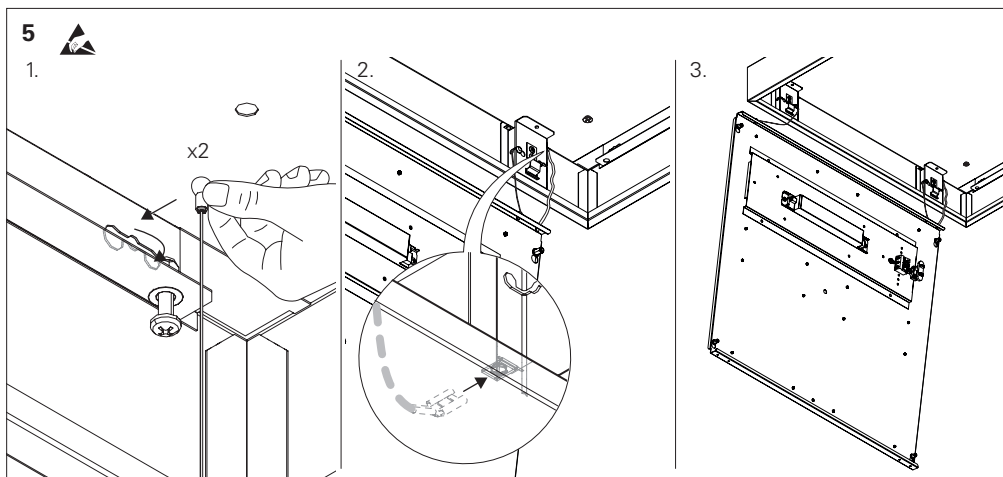
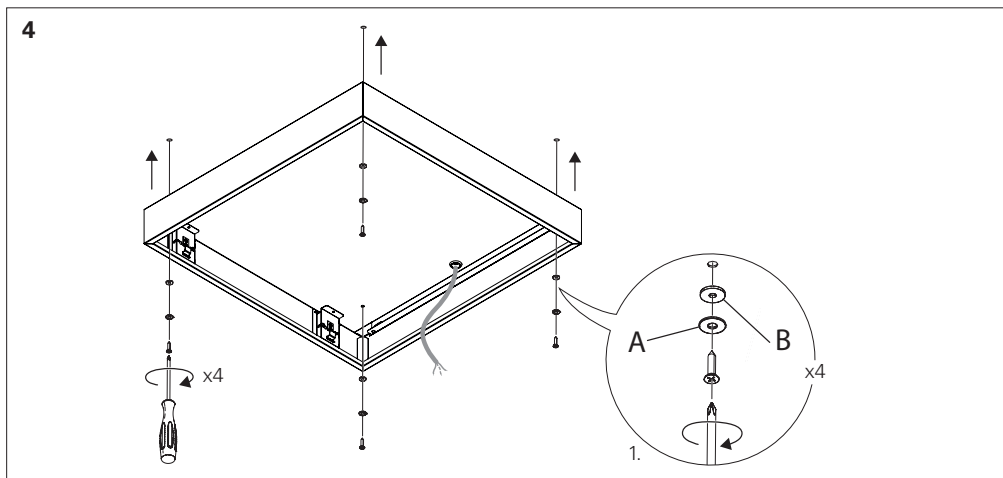

7 - HF

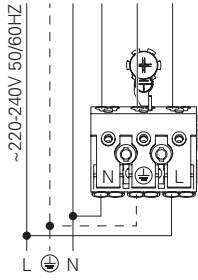

DALI

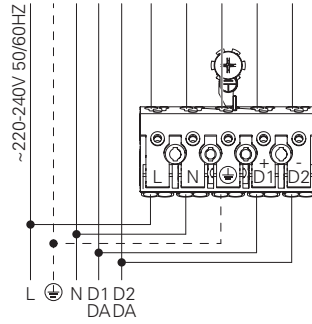

7 - HF + K3 + TEL.

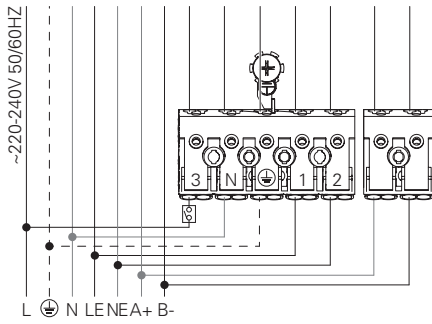

7 - DALI + K3 + TEL.

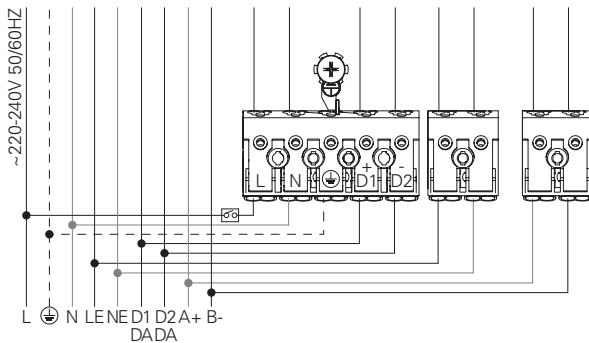

8

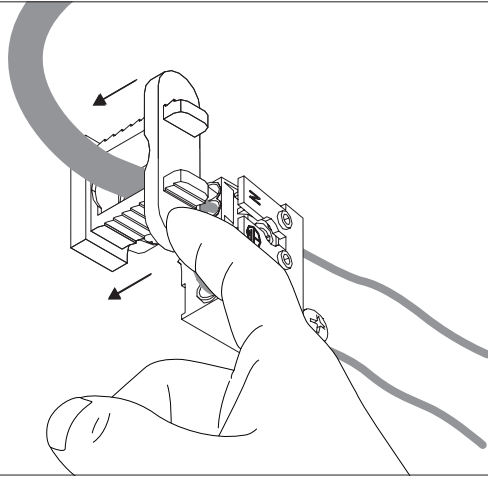

9



1.

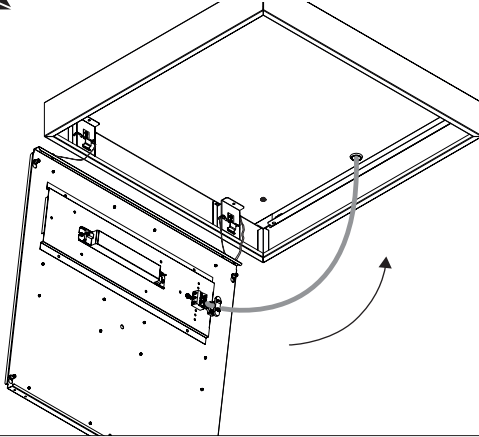

2.

x4

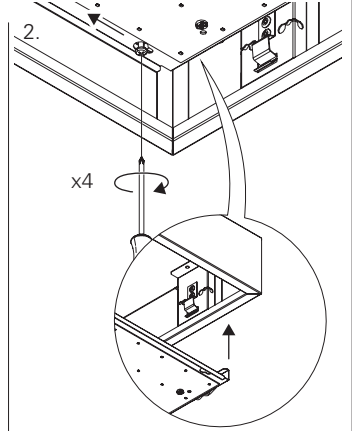

10

1.

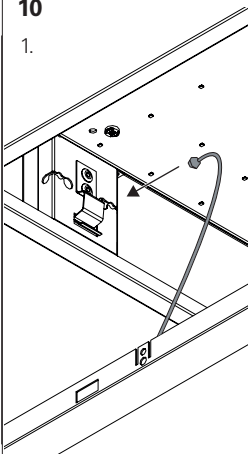

2.

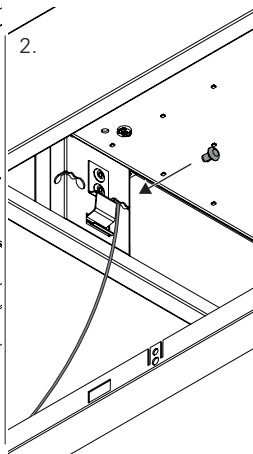

3.

