

SPECIFICATION

CUSTOMER PART NO. : XEA-040A01-DI9509-G020

PRODUCT NO. : X040DTLT-C01X6

VERSION : Ver 1.0

ISSUED DATE : 2022-12-05

This module is RoHS compliant

FOR CUSTOMER: _____

: APPROVAL FOR SPECIFICATION

: APPROVAL FOR SAMPLE

DATE	APPROVED BY

Xinli Optoelectronics :

Presented by	Reviewed by	Organized by

Note:

1.Xinli Optoelectronics reserves the right to make changes without further notice to any products herein to improve reliability, function or design.

2.All rights are reserved. No one is permitted to reproduce or duplicate the whole or part of this document without Xinli Optoelectronics' permission

2. General Description and Features

The 3.95 inch Module named X040DTLT-C01X6 is a-Si TFT-LCD module, which is the type of transmissive. It is consisted of TFT-LCD Panel, one Driver IC, one FPC, and one Back-Light unit. FPC and one Back-Light unit. Features of this product are listed in the following table. listed in the following table.

NO	Item	Contents	Unit
(1)	Module Outline	106(H)*106(V)*6.15(T)	mm
(2)	LCD Active area	71.856(H)*70.176(V)	mm
(3)	Dot Number	480*3(RGB)*480	/
(4)	Pixel pitch	0.1497 (H)*0.1462(V)	mm
(5)	LCD type	Normally Black,Transmissive	/
(6)	Display Color	262K	/
(7)	Viewing direction	All	O'clock
(8)	Backlight Type	14-chip LEDs 7S2P	/
(9)	Power Supply	3.3(TYP)	V
(10)	Drive IC	ST7701S	/
(11)	Interface	FPC0.5mm_Pitch 50pin	/
(12)	Interface type	MIPI Interface	/
(13)	Module weight	TBD	g

3. Mechanical Dimension

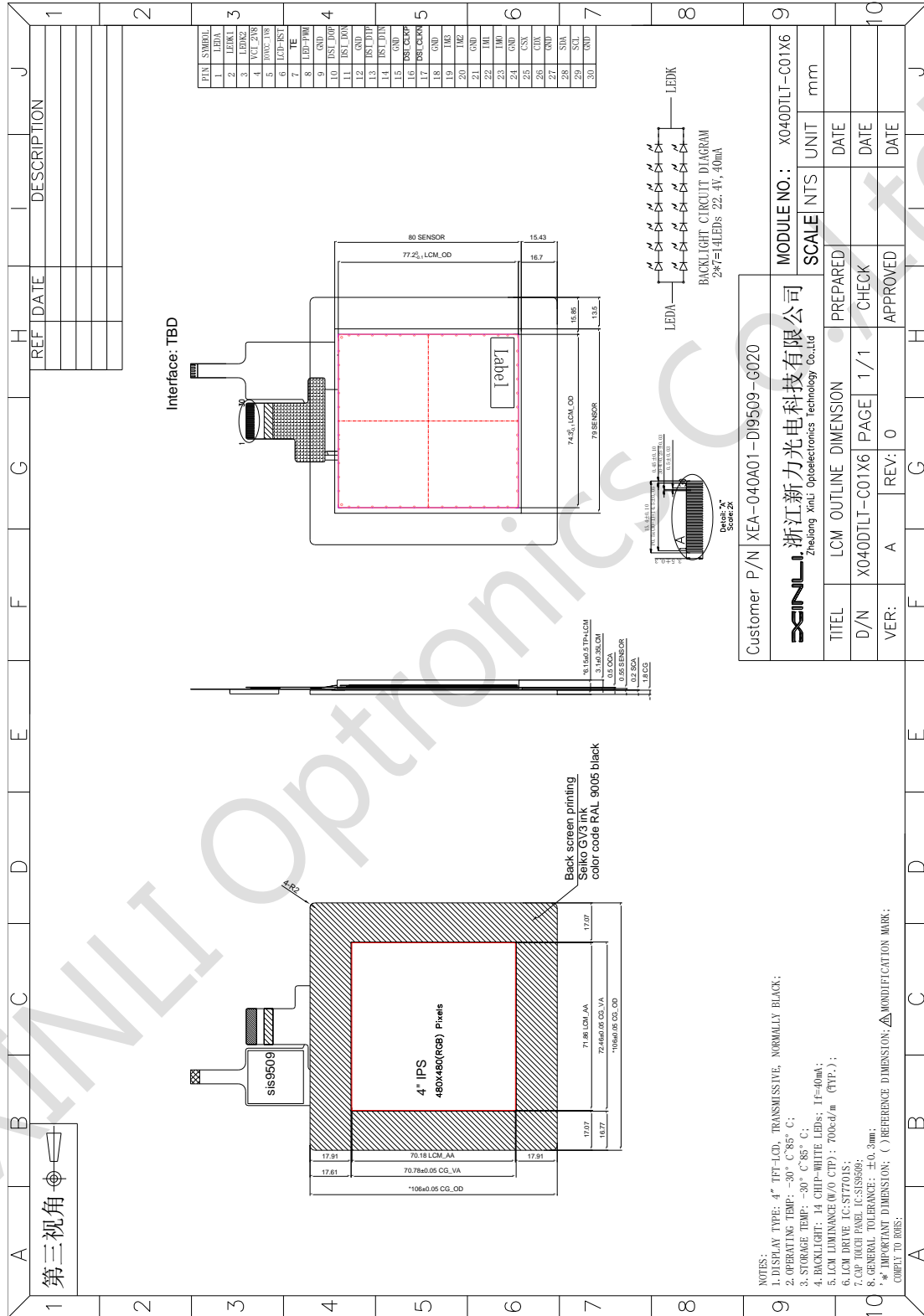

Customer: P/N XEA-040A01-DI9509-G020		MODULE NO.: X040DILT-C01X6	
浙江新力光电科技有限公司 Zhejiang Xinli Optoelectronics Co., Ltd		SCALE	UNIT
TITLE	LCM OUTLINE DIMENSION	PREPARED	DATE
D/N	X040DILT-C01X6	PAGE	1/1
VER:	A	REV:	0
		APPROVED	DATE

- NOTES:
1. DISPLAY TYPE: 4" TFT-LCD, TRANSMISSIVE, NORMALLY BLACK;
 2. OPERATING TEMP: -30° C~85° C;
 3. STORAGE TEMP: -30° C~85° C;
 4. BACKLIGHT: 1, CHIPS WHITE LEDs, IF=40mA;
 5. LCM DIMENSION (W/O CTP): 70.0±0.1mm (TYP.);
 6. LCM DRIVE IC: ST7701S;
 7. GENERAL TOLERANCE: ±0.3mm;
 8. * REFERENCE DIMENSION; () REFERENCE DIMENSION; Δ MODIFICATION MARK;
- COMPLY TO ROHS:

4. Interface Pin Connection

LCM interface Pin

NO	Symbol	Level	Description
1	LEDA	P	LED anode
2	LEDK1	P	LED Cathode
3	LEDK2	P	LED Cathode
4	VCI_2V8	P	Power supply for the analogy circuit.
5	IOVCC_1V8	P	Power supply for the logic circuit.
6	LCD-RST	I	Global reset pin , active Low.
7	TE	O	Serves TE (Tearing Effect) pin on MPU interface.
8	LED-PWM	O	LED PWM output
9	GND	P	Ground
10	DSI_D0P	I	MIPI data Input
11	DSI_D0N	I	MIPI data Input
12	GND	P	Ground
13	DSI_D1P	I	MIPI data Input
14	DSI_D1N	I	MIPI data Input
15	GND	P	Ground
16	DSI_CLKP	I	MIPI clock Input
17	DSI_CLKN	I	MIPI clock Input
18	GND	P	Ground
19	IM3	I	The System interface mode select.
20	IM2	I	The System interface mode select.
21	GND	P	Ground
22	IM1	I	The System interface mode select.
23	IM0	I	The System interface mode select.
24	GND	P	Ground
25	CSX	I	Chip selection pin
26	CDX	I	Display data/command selection pin in 4-line serial interface
27	GND	P	Ground
28	SDA	I/O	SPI_data input/output
29	SCL	I	I SPI_clock

30	GND	P	Ground
----	-----	---	--------

IM3	IM2	IM1	IM0	MPU Interface Mode
0	0	0	1	RGB+8b SPI(fall)
0	0	1	0	RGB+9b SPI(fall)
0	0	1	1	RGB+16b SPI(rise)
0/1	1	0	1	MIPI
0	1	1	0	MIPI+16b SPI(rise)
1	0	0	1	RGB+8b SPI(rise)
1	0	1	0	RGB+9b SPI(rise)
1	0	1	1	RGB+16b SPI(fall)
1	1	1	0	MIPI+16b SPI(fall)

5. Block Diagram

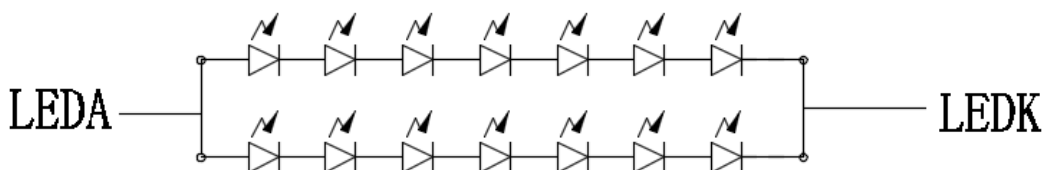
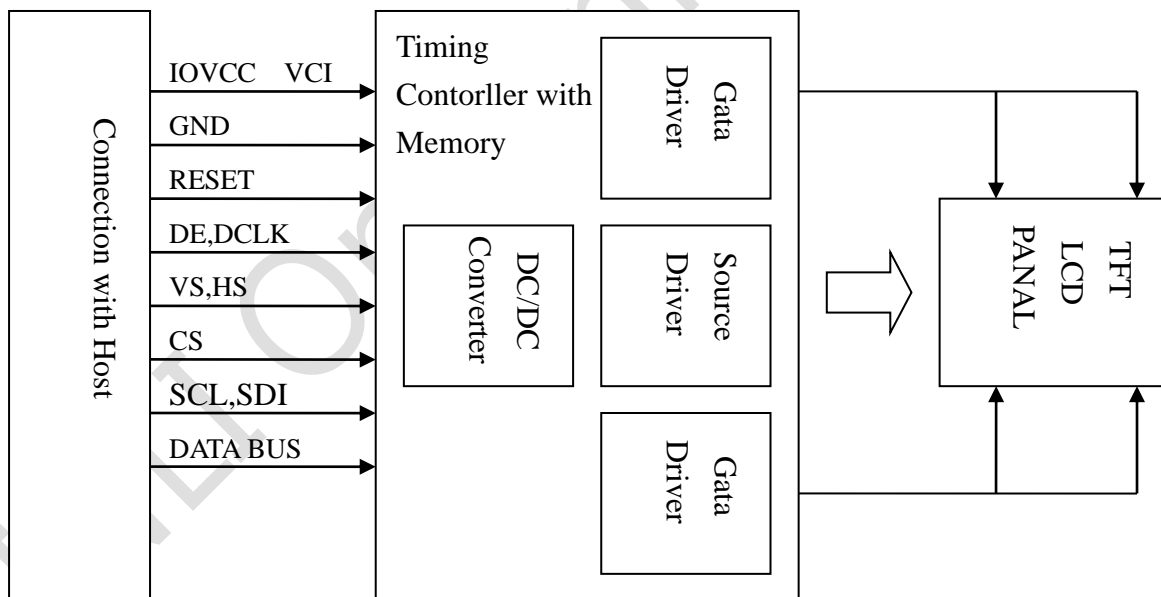

6. Maximum Rating

Item	Symbol	Rating	Unit
Operating temperature	Top	-30 to 85	°C
Storage temperature	Tst	-30 to 85	°C
Analog power supply	VCI	-0.3V ~ 4.6	V
I/O pin Power Supply Voltage	IOVCC	-0.3V ~ 4.6	V

NOTE:

If the module was used these absolute maximum ratings as above, it may be damaged permanently. Using the module within the following electrical characteristic conditions are also exceeded, the module will malfunction and cause poor reliability. VCI>GND must be maintained.

7. Electrical Characteristics

Item	Symbol	Condition	Min.	Typ.	Max.	Unit
Analog power supply	VCI	-	2.5	2.8	3.6	V
I/O pin Power Supply Voltage	IOVCC	-	1.65	1.8	3.6	V
Logic input signal Voltage	H level	V_{IH}	$0.7*IOVCC$	-	IOVCC	V
	L level	V_{IL}	GND	-	$0.3* IOVCC$	V
Logic output signal Voltage	H level	V_{OH}	$0.8* IOVCC$	-	IOVCC	V
	L level	V_{OL}	GND	-	$0.2*IOVCC$	V

8. Backlight Characteristics

Item	syb	Min	Typ	Max	Unit	Condition
Voltage	Vf	-	22.4	-	V	IF=40mA
Number of LED	-	14			pcs	-
Power Consumption	PWF	-	896	-	mW	-
Connection mode	7S2P				-	-
LED life-span	-	-	(50000)	-	Hrs	-

9. Timing Characteristics

9.1 High Speed Mode



VDDI=1.8, VDD=2.8, AGND=DGND=0V, Ta=25 °C

Signal	Symbol	Parameter	MIN	MAX	Unit	Description
DSI-CLK+/-	$2xUI_{INSTA}$	Double UI instantaneous	2.5	25	ns	
DSI-CLK+/-	UI_{INSTA} UI_{INSTB}	UI instantaneous halves	1.25	12.5	ns	$UI = UI_{INSTA} = UI_{INSTB}$
DSI-Dn+/-	tDS	Data to clock setup time	0.15	-	UI	
DSI-Dn+/-	tDH	Data to clock hold time	0.15	-	UI	

9.2 Low Power Mode

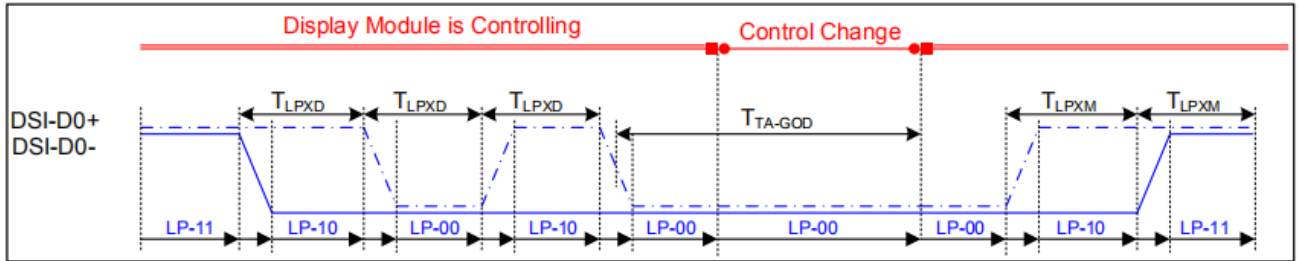
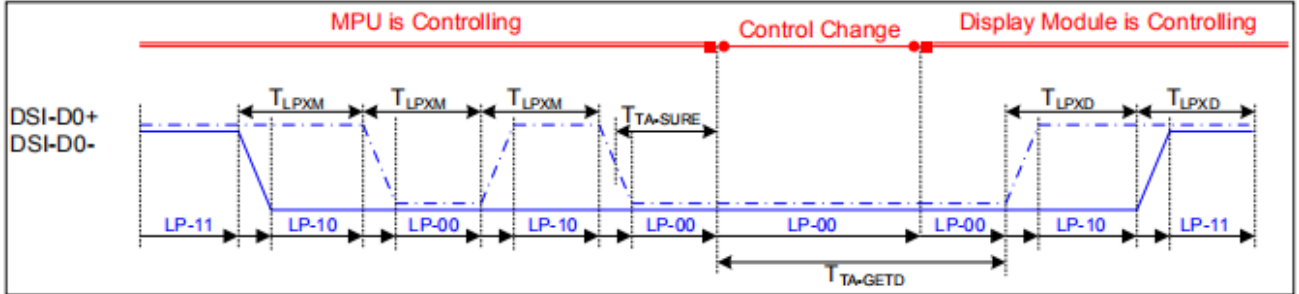

VDDI=1.8, VDD=2.8, AGND=DGND=0V, Ta=25 °C

Signal	Symbol	Parameter	MIN	MAX	Unit	Description
DSI-D0+/-	TLPXM	Length of LP-00, LP-01, LP-10 or LP-11 periods MPU→Display Module	50	75	ns	Input
DSI-D0+/-	TLPXD	Length of LP-00, LP-01, LP-10 or LP-11 periods MPU→Display Module	50	75	ns	Output
DSI-D0+/-	TTA-SURED	Time-out before the MPU start driving	T_{LPXD}	$2 \times T_{LPXD}$	ns	Output
DSI-D0+/-	TTA-GETD	Time to drive LP-00 by display module	$5 \times T_{LPXD}$		ns	Input
DSI-D0+/-	TTA-GOD	Time to drive LP-00 after turnaround request-MPU	$4 \times T_{LPXD}$		ns	Output

10. Application Circuit

Please consult our technical department for detail information.

11. Initial Code

Please consult our technical department for detail information.

12. Electro-Optical Characteristics

Item	Symbol	Condition	Min	Typ	Max	Unit	Note
Transmission (with pol)	T		-	4.2	-	%	
Response time	T_r+T_f	$\theta=0^\circ$	-	25	35	ms	4
Uniformity (Five point)	δ WHITE	$\phi=0^\circ$ $T_a=25^\circ\text{C}$		80	-	%	7
Contrast ratio	C_r		-	800	-	-	3,5
Surface Luminance	L_v		-	700	-	-	3,7
Viewing angle range	θ	$\phi=90^\circ$	-	(80)	-	deg	6
		$\phi=270^\circ$	-	(80)	-	deg	
		$\phi=0^\circ$	-	(80)	-	deg	
		$\phi=180^\circ$	-	(80)	-	deg	
Color filter chromaticity (x, y)	White	X	$\theta=\phi=$	TBD			7
		Y	0°	TBD			
	Red	X	$\theta=\phi=$	TBD			
		Y	0°	TBD			
	Green	X	$\theta=\phi=$	TBD			
		Y	0°	TBD			
	Blue	X	$\theta=\phi=$	TBD			
		Y	0°	TBD			

Note 1: Ambient temperature= $25^\circ\text{C}\pm 2^\circ\text{C}$

Note 2: To be measured in the dark room with backlight unit.

Note 3: To be measured at the center area of panel with a viewing cone of 1 by Topcon luminance meter BM-7A, after 10 minutes operation (module).

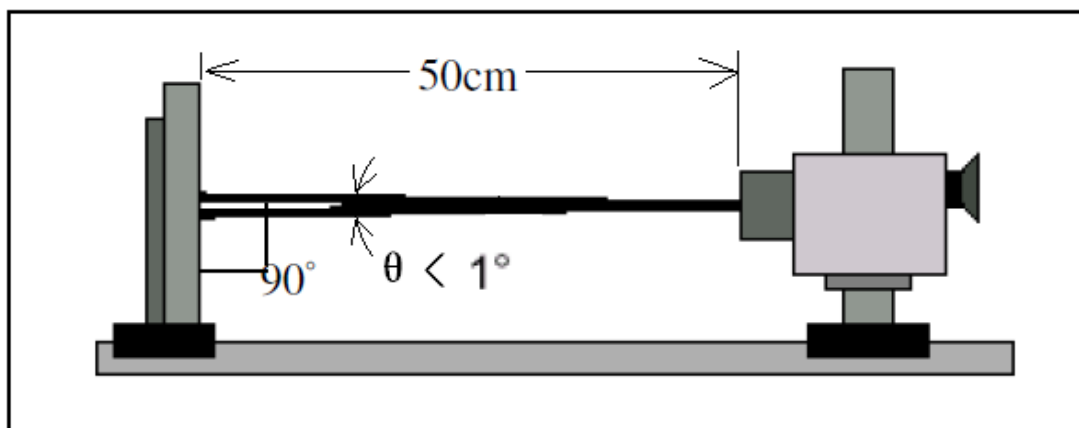

Note 4: Definition of response time:

The output signals of photo detector are measured when the input signals are changed from “black” to “white” (rising time) and from “white” to “black” (falling time), respectively. The response time is defined as the time interval between the 10% and 90% of amplitudes.

Refer to figure as below.

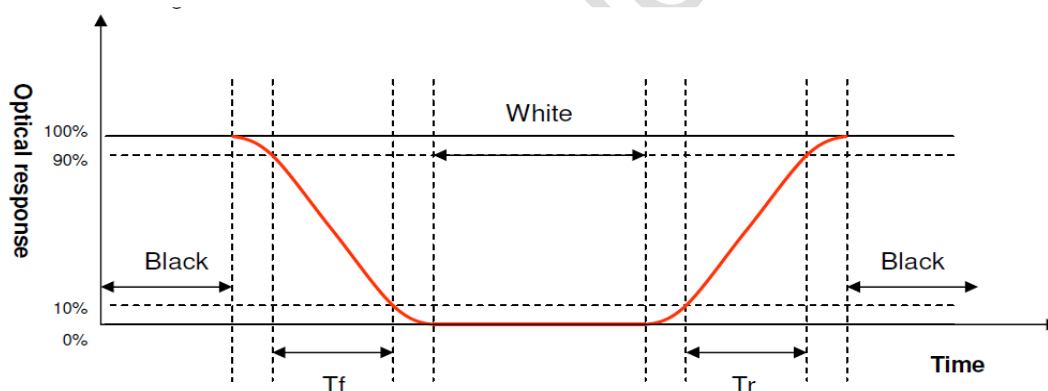

Note 5. Definition of contrast ratio:

Contrast ratio is calculated with the following formula:

$$\text{Contrast ratio (CR)} = \frac{\text{Photo detector output when LCD is at "White" state}}{\text{Photo detector output when LCD is at "Black" state}}$$

Note 6. Definition of viewing angle

Viewing angle is the angle at which the contrast ratio is greater than 2, for TFT module the contrast ratio is greater than 10. The angles are determined for the horizontal or x axis and the vertical or y axis with respect to the z axis which is normal to the LCD surface.

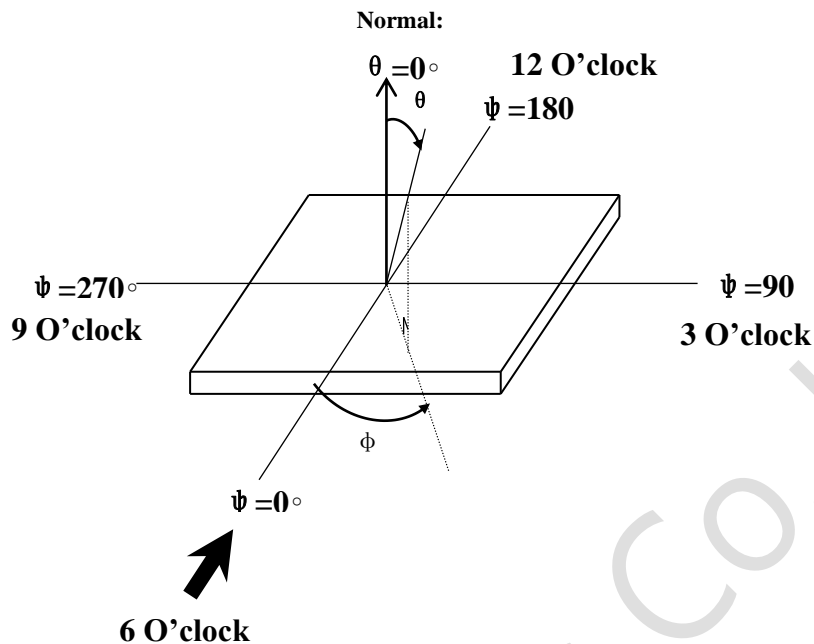

Note 7. Surface luminance is the LCD surface from the surface with all pixels displaying white. Refer to figure as below.

Measuring method for Contrast ratio, surface luminance, Luminance uniformity, CIE (x, y) chromaticity

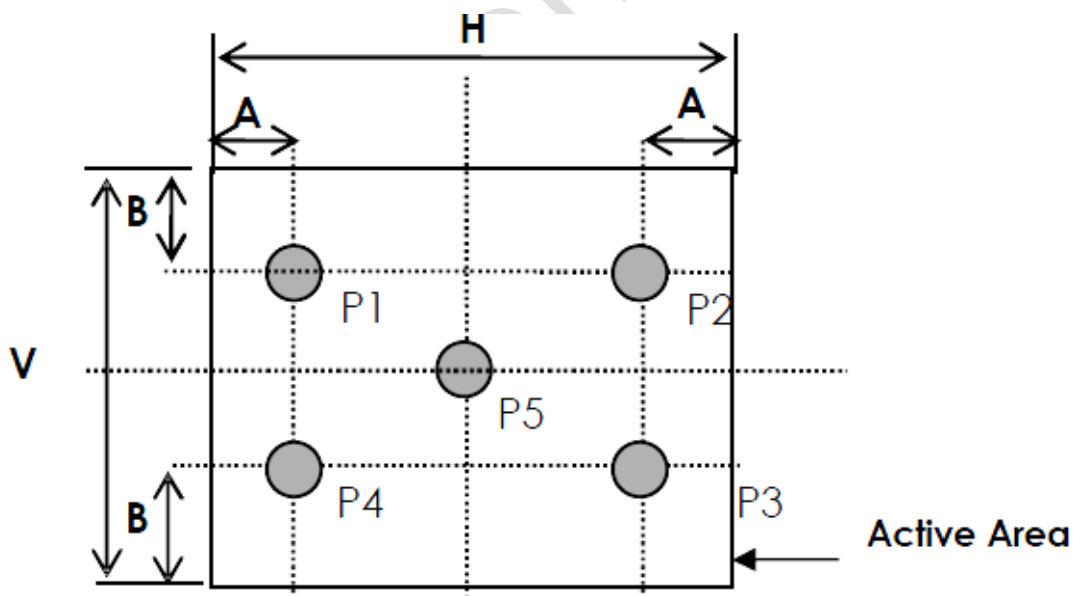

A : 5 mm B : 5 mm H,V : Active Area

Light spot size $\Phi=7\text{mm}$, 500mm distance from the LCD surface to detector lens

measurement instrument is TOPCON's luminance meter BM-7A

Uniformity definition= [min of 5point/max of 5points]x100%

Lv = Surface Luminance with all white pixels (P5)

13. Quality Assurance

TBD.

14. Reliability Test

This standard reliability test is done only for the first lot of MP products.

Customer and supplier must hold a discussion if other reliability test is requested by customer.

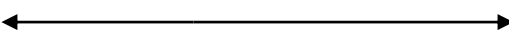
NO.	Test Item	Description	Test Condition
1	High temperature storage	Endurance test applying the high storage temperature for a long time	85°C, 240H
2	Low temperature storage	Endurance test applying the low storage temperature for a long time	-30°C, 240H
3	High temperature operation	Endurance test applying the electric stress under high temperature for a long time	85°C, 240H
4	Low temperature operation	Endurance test applying the electric stress under low temperature for a long time	-30°C, 240H
5	High temperature /humidity storage	Endurance test applying the high temperature and high humidity storage for a long time	60°C, 90% RH, 120H
6	Temperature Cycle	Endurance test applying the low and high temperature cycle $-30^{\circ}\text{C} \leftarrow \rightarrow 25^{\circ}\text{C} \leftarrow \rightarrow 80^{\circ}\text{C}$ $30\text{min} \leftarrow \rightarrow 5\text{min} \leftarrow \rightarrow 30\text{min}$  one cycle	-30°C/80°C, 100 cycles
7	ESD Test	To check the product operating capability after electrostatic environment.	Voltage: $\pm 2\text{KV}$ (contact discharge); $\pm 4\text{KV}$ (air discharge)
8	FPC (pull-plugging test and flexural test)	To check the product after FPC pull-plugging test and flexural test.	Pull-plug: 10 times under normal use; Flexural: radiang0.38mm 10 times

9	Drop Test (package)	To check the product break or not after dropping from 0.7m.	drop direction/times: 1.one time each 6 faces 2.one time any 3 ridges 3.one time any 1 corner
10	Pencil hardness	A pencil with a hardness of 7H an a load of 750g. Without scratching the surface,can be judged as OK.	Will noe scratch the surface
11	UV aging	UV Light 340nM,0.668mW/m ² @62° C,for 600 hours.	No change color
12	Collision level	The impact of a 1.7Kg object falling from a height of 300mm on the surface	No rupture

15. Precautions for Operation and Storage

1. Precautions for Operation

- (1)Since LCD panel made of glass,in order to prevent from glass broken or color tone change,please do not apply any mechanical shock or impact or excessive force to it when installing the LCD module.
- (2)If LCD panel is broken and liquid crystal substance leaks out and contact your skin or clothes,please immediately wash it off by using soap and water.
- (3)The polarizer on the LCD surface is soft and easily scratched.Please be careful when handling.
- (4)If LCD surface becomes contaminated,please wipe it off gently by using moisten soft cloth with normal hexane,do not use acetone,ketone,ethanol, alcohol or water.If there is saliva or water on the LCD surface,please wipe it off immediately.
- (5)When handing LCD module,please be sure that the body and the tools are properly grounded.And do not touch I/F pins with bare hands or contaminate I/F pins.
- (6)Do not attempt to disassemble or process the LCD module.
- (7)LCD module should be used under recommended operating conditions shown in chapter 6 and 7.
- (8)Response time will be extremely slower at lower temperature than at specified temperature and LCD will show different color when at higher temperature.The phenomenon will disappear when returning to specified condition.
- (9)Foggy dew,moisture condensation or water droplets deposited on surface

and contact terminals will cause polarizer stain or damage, the deteriorated display quality and electrochemical reaction then leads to the shorter life time and permanent damage to the module probably. Please pay attention to the environmental temperature and humidity.

1. Precautions for Storage

(1) Please store LCD module in a dark place, avoid exposure to sunlight, the light of fluorescent lamp or any ultraviolet ray.

(2) Keep the environment temperature at between 10°C and 35 °C and at normal humidity. Avoid high temperature, high humidity or temperature below 0°C.

(3) That keeps the LCD modules stored in the container shipped from supplier before using them is recommended.

(4) Do not leave any article on the LCD module surface for an extended period of time.

2. Warranty period

Warrants for a period of 12 Months from the shipping date when stored or used under normal condition.

16. Package Specification

TBD.