

# event line array

EVENT-28A / EVENT-118A

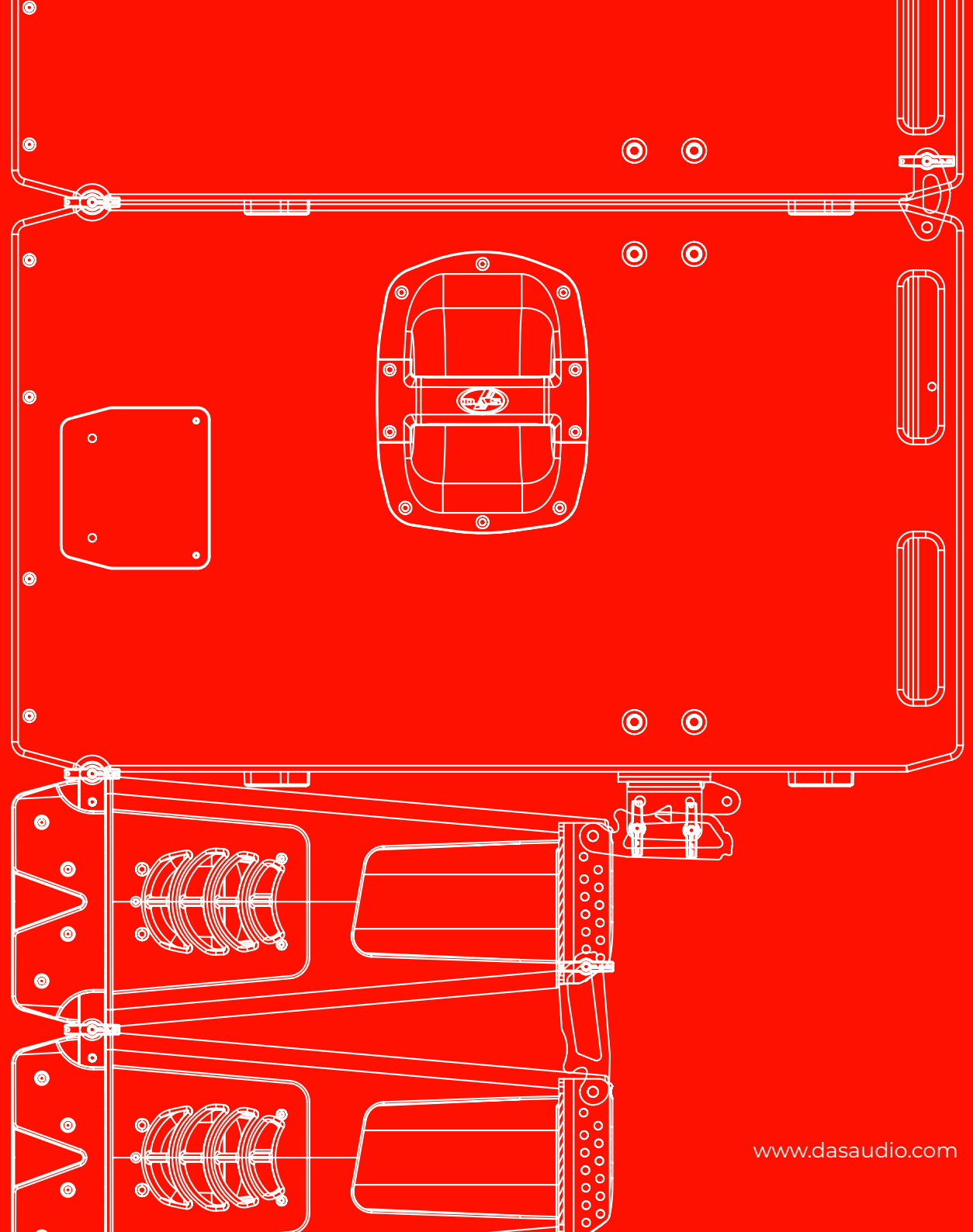

SOUND WITH SOUL

[www.dasaudio.com](http://www.dasaudio.com)



Before operating the device, please read the “Safety precautions” section of this manual. Retain this manual for future reference.

<b>1. Safety precautions</b>	<b>5</b>	<b>8. Rigging system</b>	<b>27</b>
<b>2. Declaration of conformity</b>	<b>6</b>	4 or 6 units mounting on a PL-EV28S flatbed dolly	
<b>3. Warranty</b>	<b>7</b>	Array mounting of groups of 4 units on a flatbed dolly	
<b>4. Introduction</b>	<b>9</b>	EVENT-118A array mounting	
<b>5. Configurations</b>	<b>10</b>	EVENT-28A array mounting “one by one”	
2 x EVENT-28A + 2 x EVENT-118A		EVENT-118A + EVENT-28A array mounting	
8 x EVENT-28A + 2 x EVENT-118A		Stacking EVENT-28A on EVENT-118A	
8 x EVENT-28A + 4 x EVENT-118A		Transporting	
12 x EVENT-28A + 6 x EVENT-118A		<b>9. Annex:</b>	<b>41</b>
16 x EVENT-28A + 8 x EVENT-118A		Line connections: unbalanced and balanced	
24 x EVENT-28A + 12 x EVENT-118A			
12 x EVENT-28A + 4 x EVENT-118A			
<b>6. Specifications</b>	<b>15</b>		
<b>7. Line drawing</b>	<b>16</b>		
<b>8. Amplifiers</b>	<b>18</b>		
DAScontrol and display navigation			
Recommendations of use			
Troubleshooting			



## Safety precautions

The exclamation point inside an equilateral triangle is intended to alert the users to the presence of important operating and maintenance (servicing) instructions in the literature accompanying the product. Heed all warnings. Follow all instructions. Keep these instructions.

**WARNING:** This is a class A product. In a domestic environment this product may cause radio interferences in which case the user may be required to take adequate measures.

Use this product only in E1, E2, E3 or E4 environments according to EN55103-2.

Do not remove mains connector ground, it is dangerous and illegal. Class I device. The product must be connected to a mains socket outlet with protective earth connection. Only use this equipment with an appropriate mains cord for your country.

The lightning and arrowhead symbol warns about the presence of uninsulated dangerous voltage. To reduce the risk of electric shock, do not remove the cover.

Do not install near any heat sources such as radiators, heat registers, stoves or other apparatus that produce heat. The circulation of air through the heatsink must not be blocked.

Do not expose this device to rain or moisture. Do not use this apparatus near water (for example, swimming pools and fountains). Do not place any objects containing liquids, such as bottles or glasses, on the top of the unit. Do not splash liquids on the unit. IP-43 equipment.

This symbol on the product indicates that this product should not be treated as household waste. Instead it shall be handed over to the applicable collection point for the recycling of electrical and electronic equipment.

Working temperature ranges from 15°C to 45°C with a relative humidity of 95%, with  $\pm 10\%$  of the rated main voltage value indicated on the rear label. If the fuse needs to be replaced, please pay attention to correct type and ratings.

The outer wiring connected to the device requires installation by an instructed person or the use of a flexible cable already prepared.



If the apparatus is connected permanently, the electrical system of the building must incorporate a multipolar switch with a separation of contact of at least 3mm in each pole.

To disconnect the device, you should use the mains plug. Unplug this apparatus during lightning storms, earthquakes or when unused for long periods of time.

Do not place loudspeakers in proximity to devices sensitive to magnetic fields such as television monitors or data storage magnetic material.

For EVENT-28A, the maximum safety height from floor to bottom of enclosure when mounting on a TRD-2 tripod (it needs also AXS-EV28),

with legs spread 55cm from the central pole, is:

1x EVENT-28A----- >142 cm

2x EVENT-28A----- >132 cm



The appliance should be flown only from the rigging points and by qualified personnel. Do not suspend the box from the handles.

No user serviceable parts inside. Refer all servicing to qualified service personnel. Servicing is required when the apparatus has been damaged in any way, such as power-supply cord or plug is damaged, liquid has been spilled or objects have fallen into the apparatus, the apparatus has been exposed to rain or moisture, does not operate normally or has been dropped.

Clean only with a dry cloth. Do not use any solvent based cleaners.



## Declaration of conformity

### **DAS Audio Group, S.L.**

C/ Islas Baleares, 24 - 46988

Pol. Fuente del Jarro - Valencia. Spain

Declares that models EVENT-26A and EVENT-115A:

Abide by essential objectives relating Directives:

- Low Voltage Directive 2014/35/UE
- EMC Directive 2014/30/UE
- RoHS Directive 2011/65/UE
- WEEE Directive 012/19/UE
- Commission Delegated Directive 2015/863/EU and amendments

In accordance with Harmonized European Norms:

- EN 62368-1:2020 + A11:2020
- Audio/video, information and communication technology equipment - Part 1: Safety requirements
- EN 55032:2015 + A11:2020 + A1:2020
- Electromagnetic compatibility of multimedia equipment. Emission requirements.
- EN 55035:2017 + A11:2020 Electromagnetic compatibility of multimedia equipment. Immunity requirements.
- EN IEC 63000:2018 Technical documentation for the assessment of electrical and electronic products with respect to the restriction of hazardous substances.

## Event Series | **Warranty**

All our products are warranted against any manufacturing defect for a period of 24 months from date of purchase.

The warranty excludes damage from incorrect use of the product.

All warranty repairs must be exclusively undertaken by the factory or any of its authorised service centers.

To claim a warranty repair, do not open or intend to repair the product.

All the details related to the warranty (such as extended warranties) can be found in the SUPPORT section on our website: [www.dasaudio.com](http://www.dasaudio.com)

### EVENT-28A

The EVENT-28A is an advanced symmetrical, compact, two-way powered line array system. Designed to provide outstanding performance and ease of use, this system features a stylish and portable polypropylene cabinet design that is both road-worthy and highly durable. With a comprehensive range of accessories, the EVENT-28A is perfect for small to mid-size rental and installation applications seeking superior sound quality.

- Ultra-compact, lightweight powered line array
- High-efficiency Class D amplifier with SMPS
- Dual voltage mains for use anywhere in the world
- Easy system configuration thanks to DAScontrol™
- High-end 24-bit DSP with LCD screen
- FIR processing for constant phase response
- FSS™ Fast Set Splay rigging for quick deployment

This system integrates two 8" neodymium transducers and a single M-60 compression driver into a robust yet lightweight polymer cabinet. The 8" transducers, enhanced with neodymium magnets for reduced weight, ensure efficient sound projection and superior low-frequency response. The symmetric "V" shaped configuration of the cone transducers delivers consistent 100° horizontal coverage down to 200 Hz. The M-60 compression driver remains coupled to an advanced waveguide design, which controls the vertical dispersion and ensures precise coupling between units in vertical arrays.

Powered by a two-channel Class D amplifier, the EVENT-28A boasts 1300 W<sub>peak</sub> power. The amplifier's rear panel is equipped with high-quality Neutrik® XLR and powerCON connectors. Using the DAScontrol™ interface, users can quickly select presets based on the number of units in the array. The onboard DSP utilizes a 24-bit high-end processor to manage crossover, EQ, delay, and limiter functions.

Incorporating FIR filtering technology, the EVENT-28A maintains constant phase response, leading to transparent sound and exceptional clarity that enhances the overall listening experience.

Installation and deployment of EVENT-28A arrays are streamlined with the innovative Fast Set Splay (FSS™) rigging system, which allows for quick angle selection while stacked on dollies. The stainless-steel rigging hardware supports flown arrays of up to 18 units, adjustable in 1° increments from 0° to 10°.

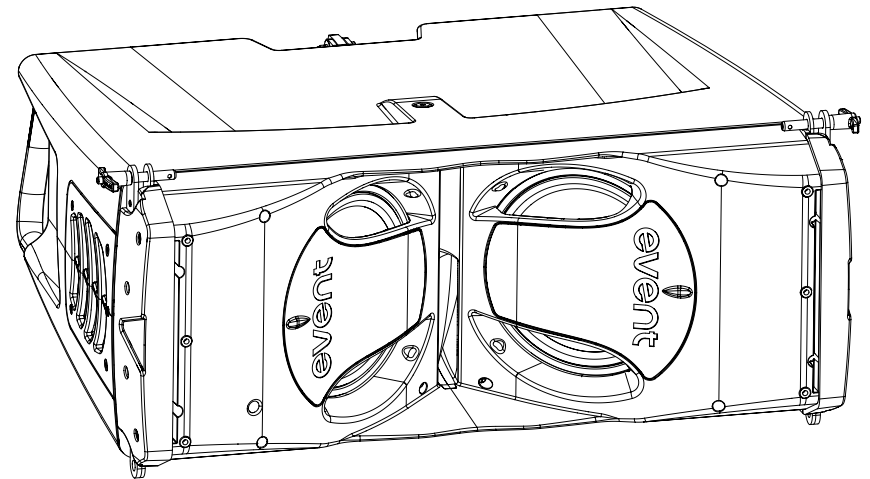

The EVENT-28A pairs seamlessly with the flyable companion subwoofer, the EVENT-118A, ensuring robust low-frequency reinforcement. Weighing 20 kg, the EVENT-28A strikes an excellent balance between size, performance, and portability, making it an ideal solution for a wide array of sound reinforcement applications.

### EVENT-118A

The EVENT-118A is a robust powered subwoofer system that incorporates a frontloaded 18" lowfrequency transducer developed by DAS, designed to deliver profound and accurate bass reinforcement. As the companion subwoofer for the EVENT-28A, it shares a compatible rigging system, allowing for seamless integration whether the EVENT-28A is flown from or stacked above the EVENT-118A.

The 18FWN 18" loudspeaker, engineered by DAS, is central to the EVENT-118A's powerful performance. Optimized using Finite Element Analysis (FEA) and equipped with neodymium magnets for reduced weight, the 18FWN offers an extended 3" voice coil for high efficiency and long excursion. This design allows for a power handling capacity of 2000 W<sub>peak</sub>, ensuring the subwoofer delivers deep, impactful bass.

Efficient cooling is achieved through the vented pole piece and numerous apertures in the speaker's back plate, which significantly reduce power compression and enable high acoustic output over extended periods.

The system is driven by a cutting-edge 2000 W<sub>peak</sub> Class D amplifier, providing ample power for any setting. Quality Neutrik® XLR input connectors and stereo "loop thru" outputs on the rear panel provide signal continuity for the EVENT-28A systems or other components in a larger setup. Digital presets accessible via the DAScontrol™ interface on the rear of the cabinet simplify system configuration, making setup quick and user-friendly. The EVENT-118A also offers a simple selection of cardioid presets when used in pairs or groups of three units, effectively minimizing rearward sound radiation and optimizing bass coverage.

Constructed from Birch plywood, the EVENT-118A's enclosure is robust and designed for longevity. The cabinet is finished with DAS ISO-flex protective coating, enhancing durability and making it suitable for both installation and touring applications. The rigging hardware is fully compatible with the EVENT-28A, allowing various configurations, whether flown or stacked. Additionally, a pole mount socket on the top of the unit supports combo configurations with the EVENT-28A or other compatible full-range systems.

- Active front-loaded subwoofer system
- 1 x 18" DAS 18FW4N loudspeaker
- High-efficiency Class D amplifier with SMPS
- Dual voltage mains for use anywhere in the world
- Easy system configuration thanks to DAScontrol™
- High-end 24-bit DSP with LCD screen
- EVENT-28A compatible rigging hardware

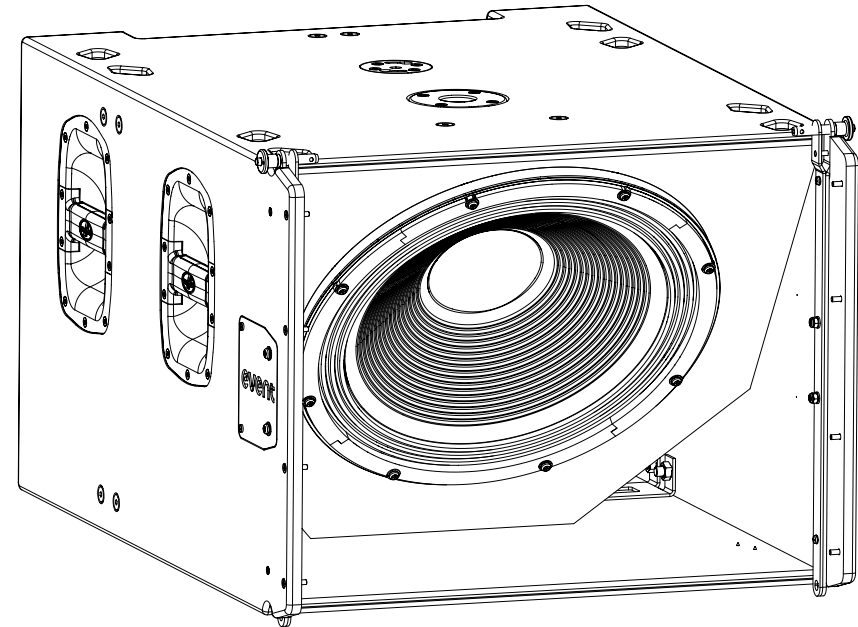

## Event Series | **Configurations**

2 x EVENT-28A + 2 x EVENT-118A

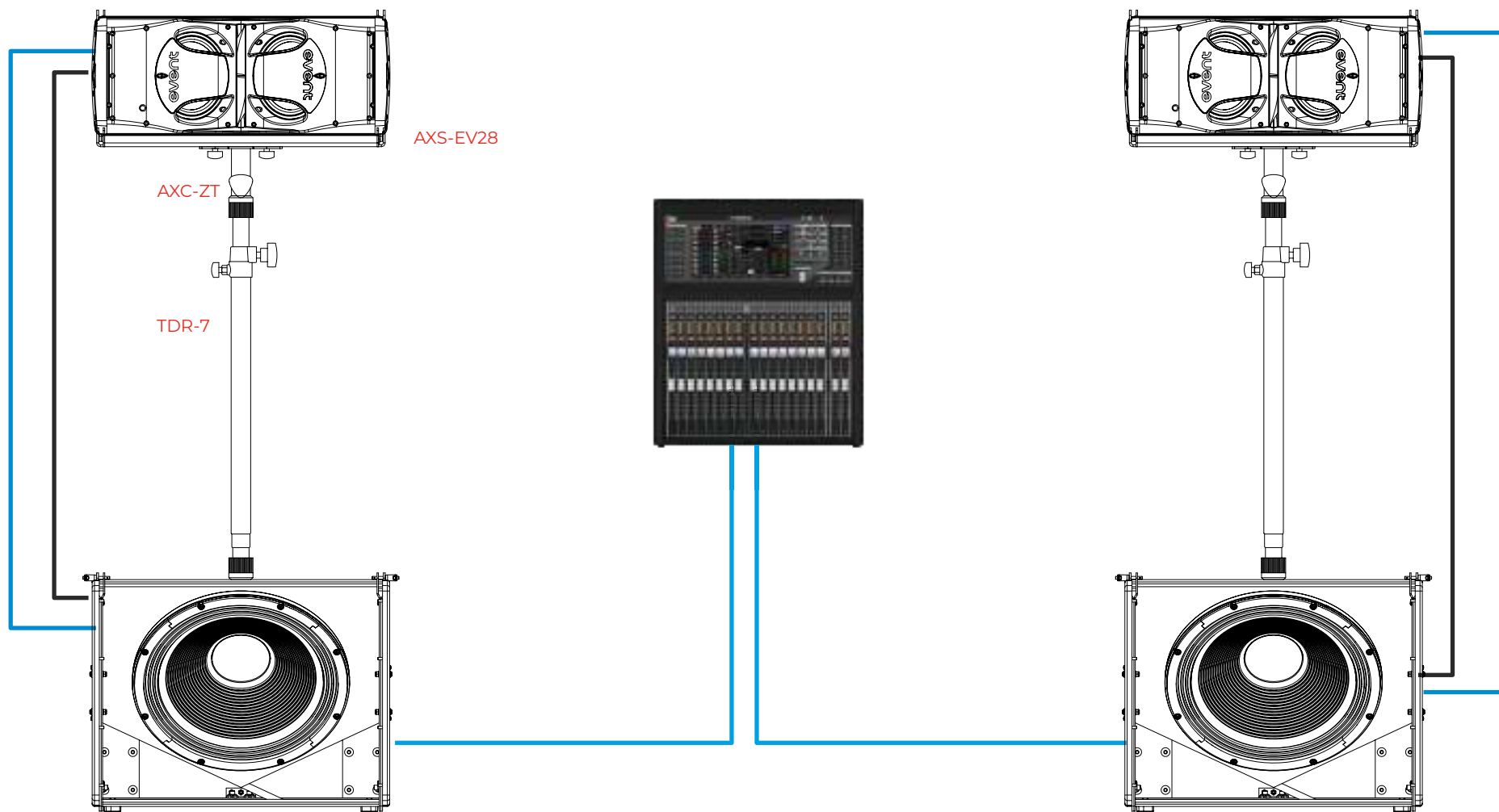

# Event Series | Configurations

8 x EVENT-28A + 2 x EVENT-118A

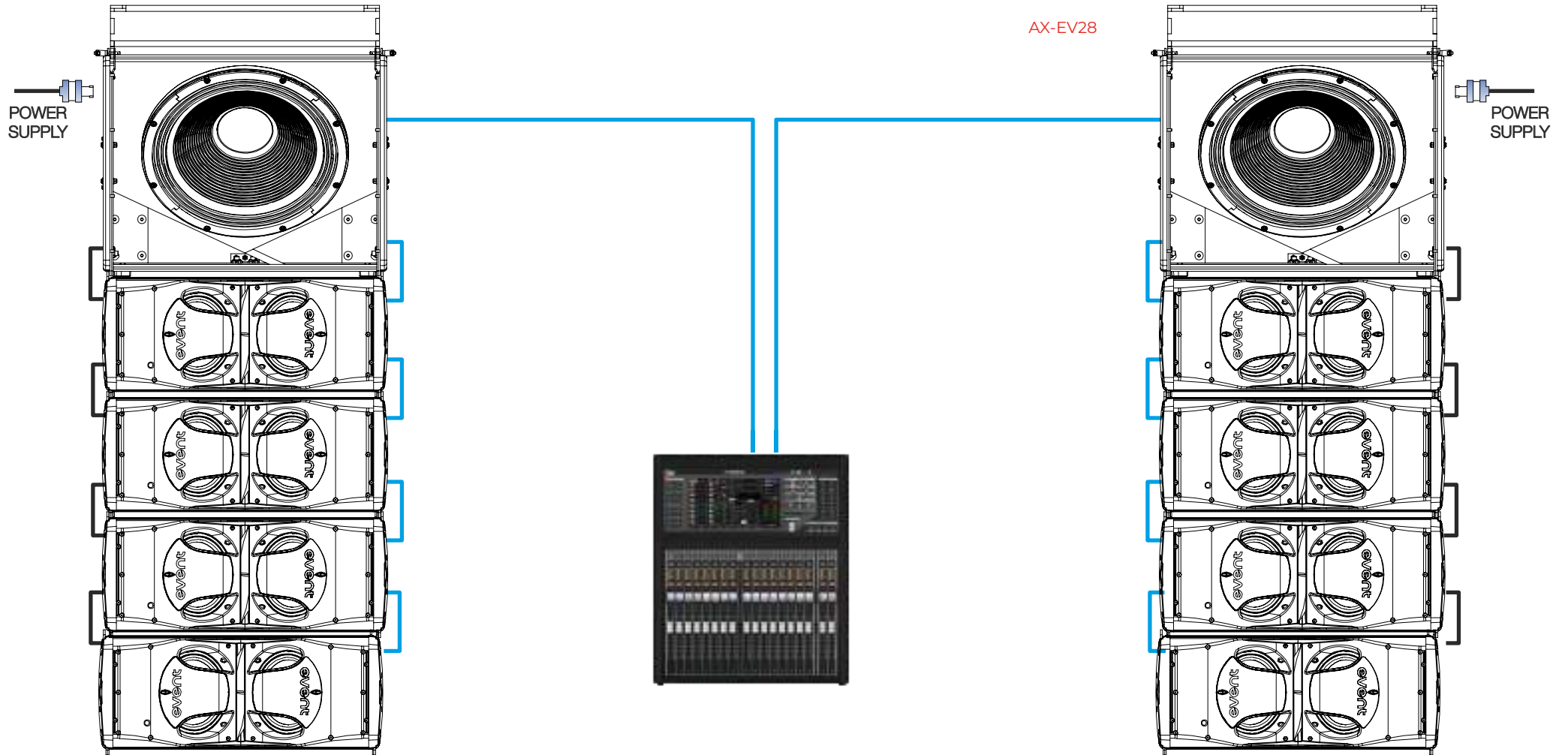

# Event Series | Configurations

8 x EVENT-28A+ 4 x EVENT-118A

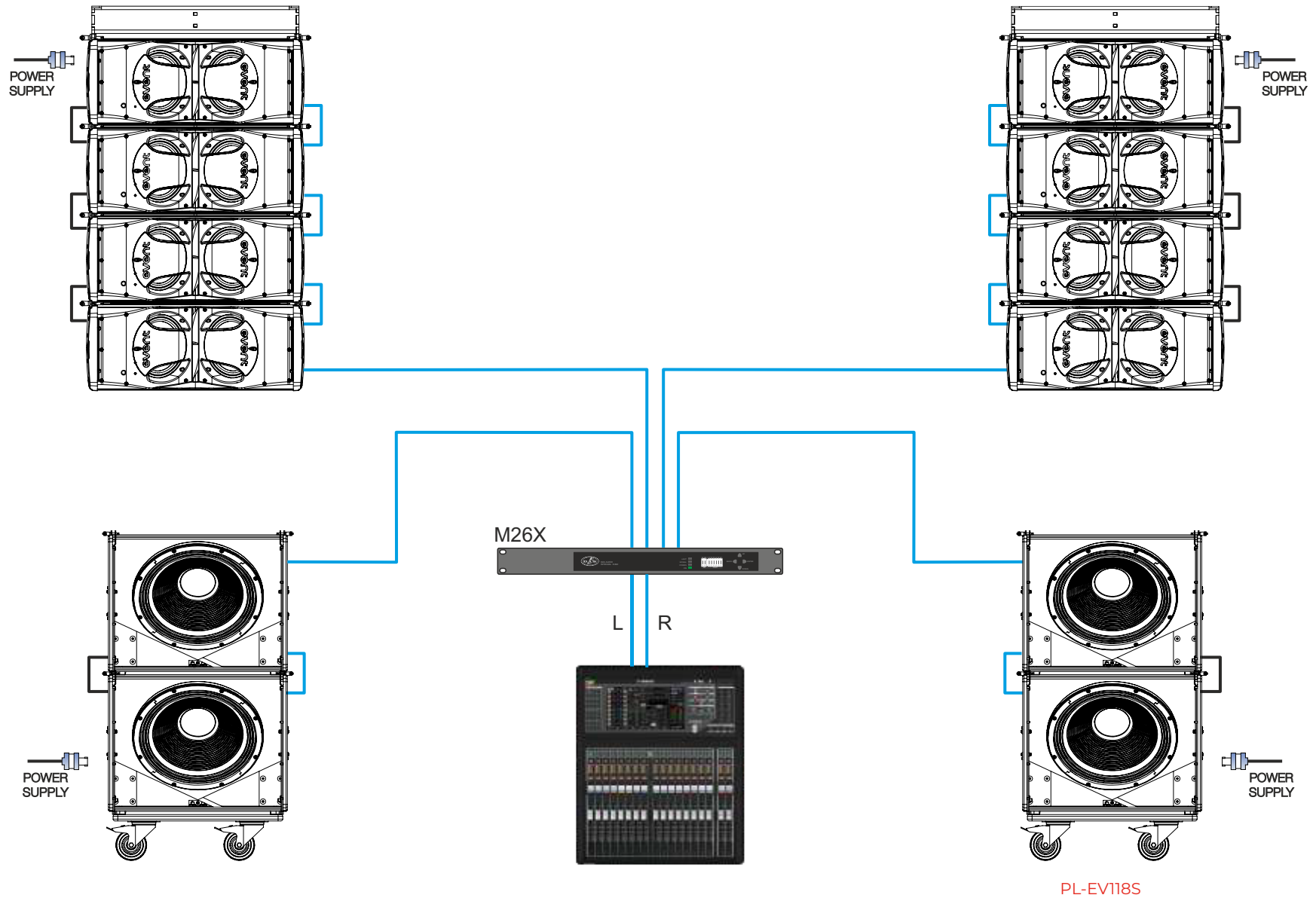

# Event Series | Configurations

12 x EVENT-28A + 6 x EVENT-118A

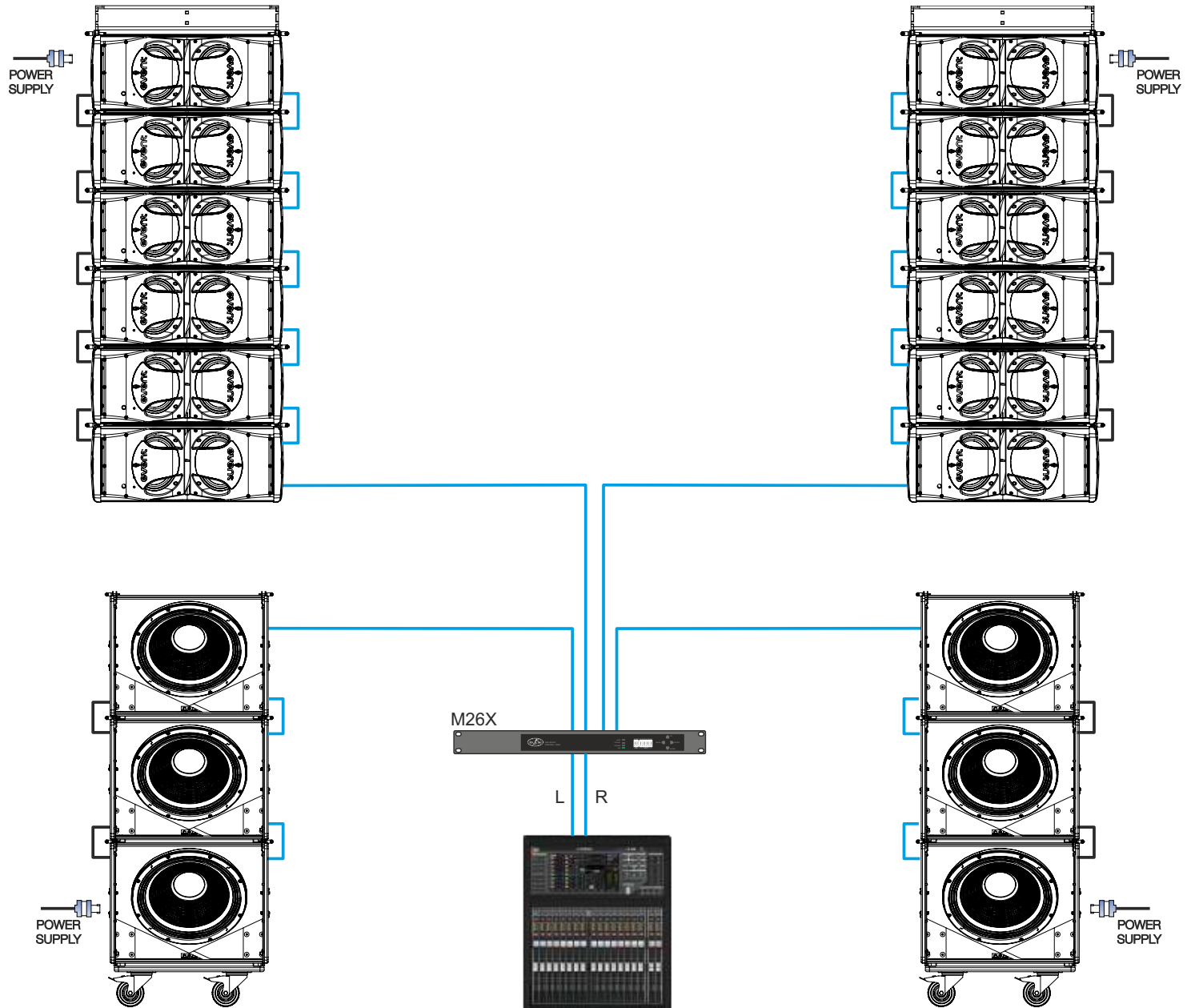

## Event Series | Configurations

16 x EVENT-28A + 8 x EVENT-118A

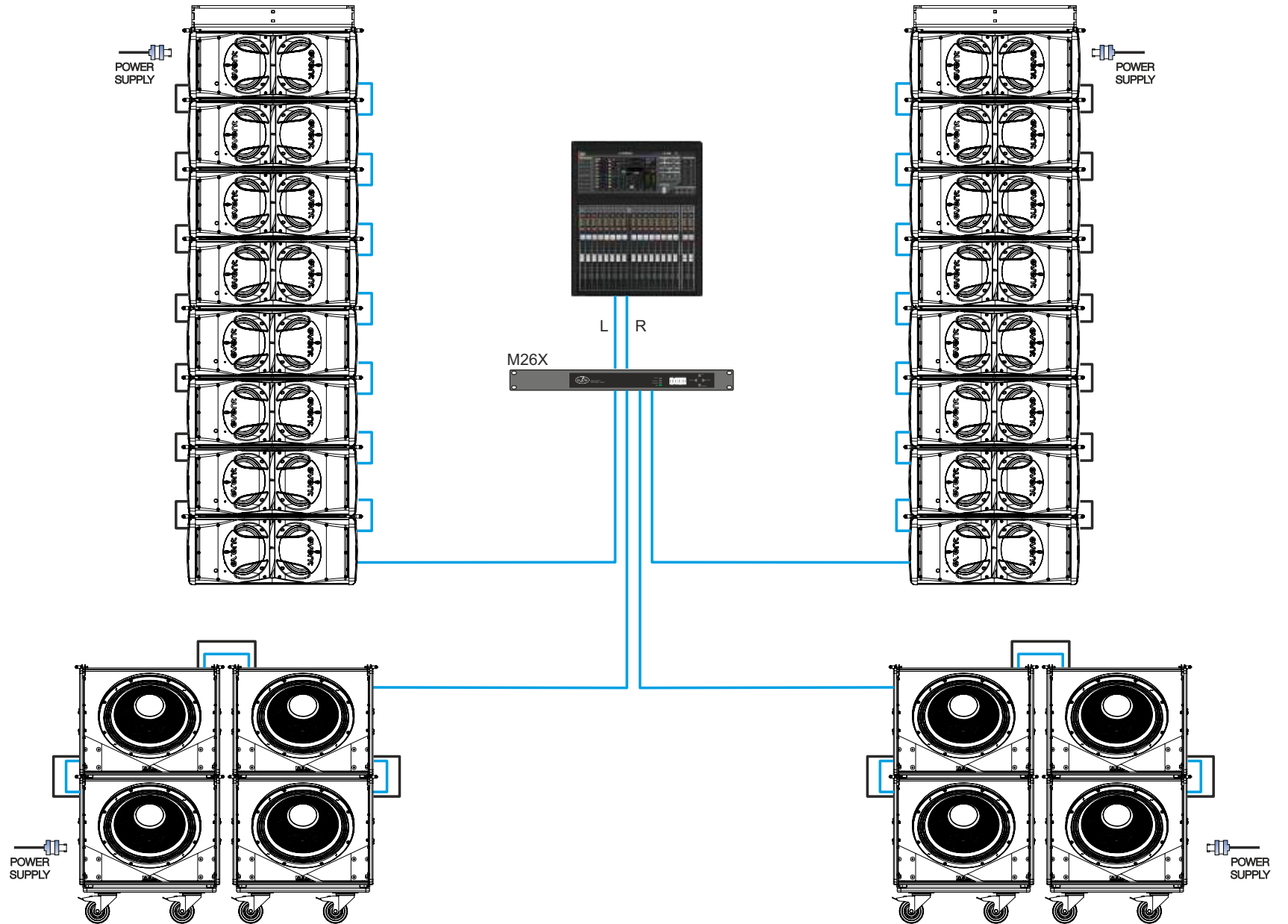

# Event Series | Configurations

24 x EVENT-28A + 12 x EVENT-118A

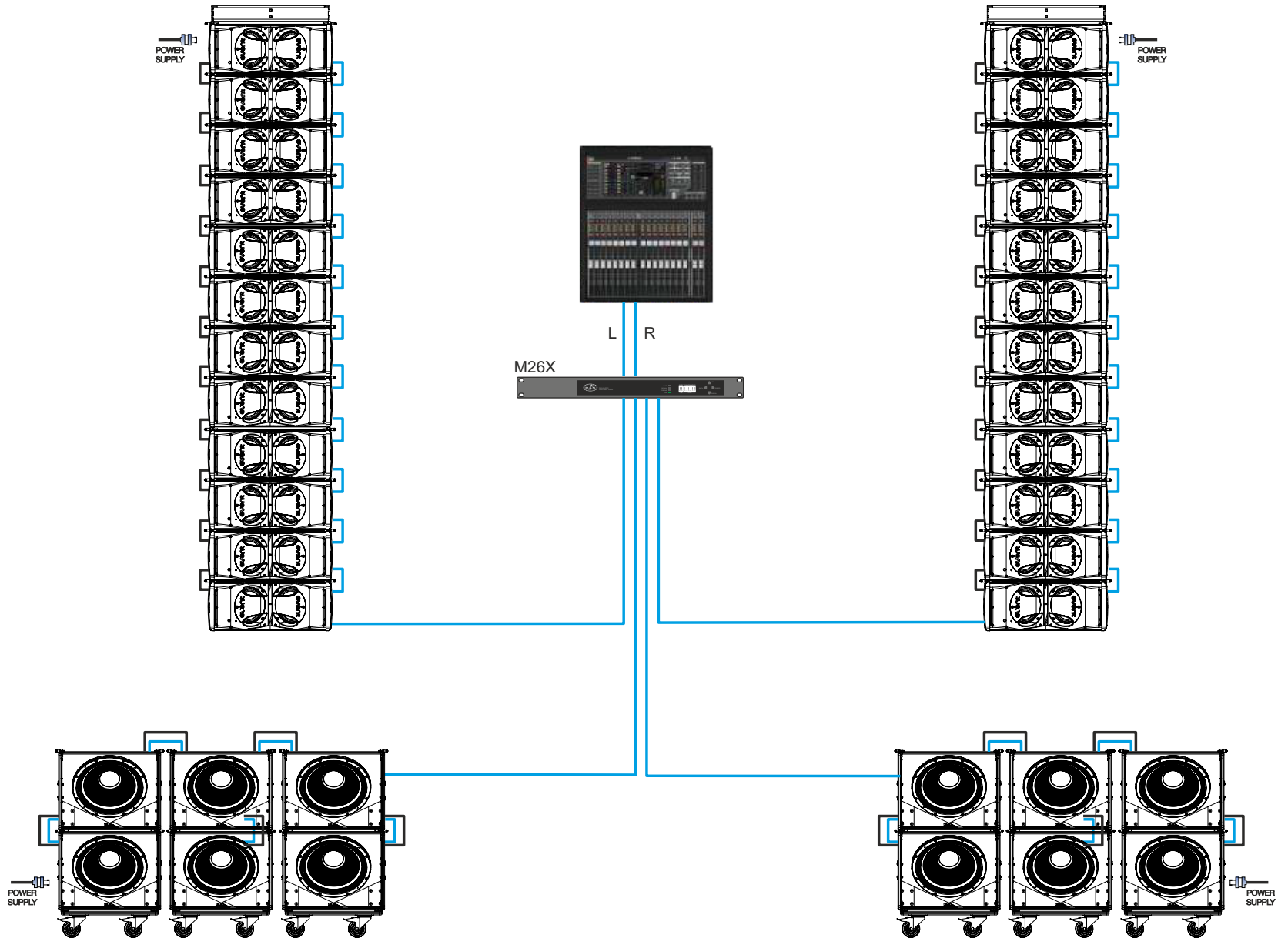

# Event Series | Configurations

12 x EVENT-28A + 4 x EVENT-118A

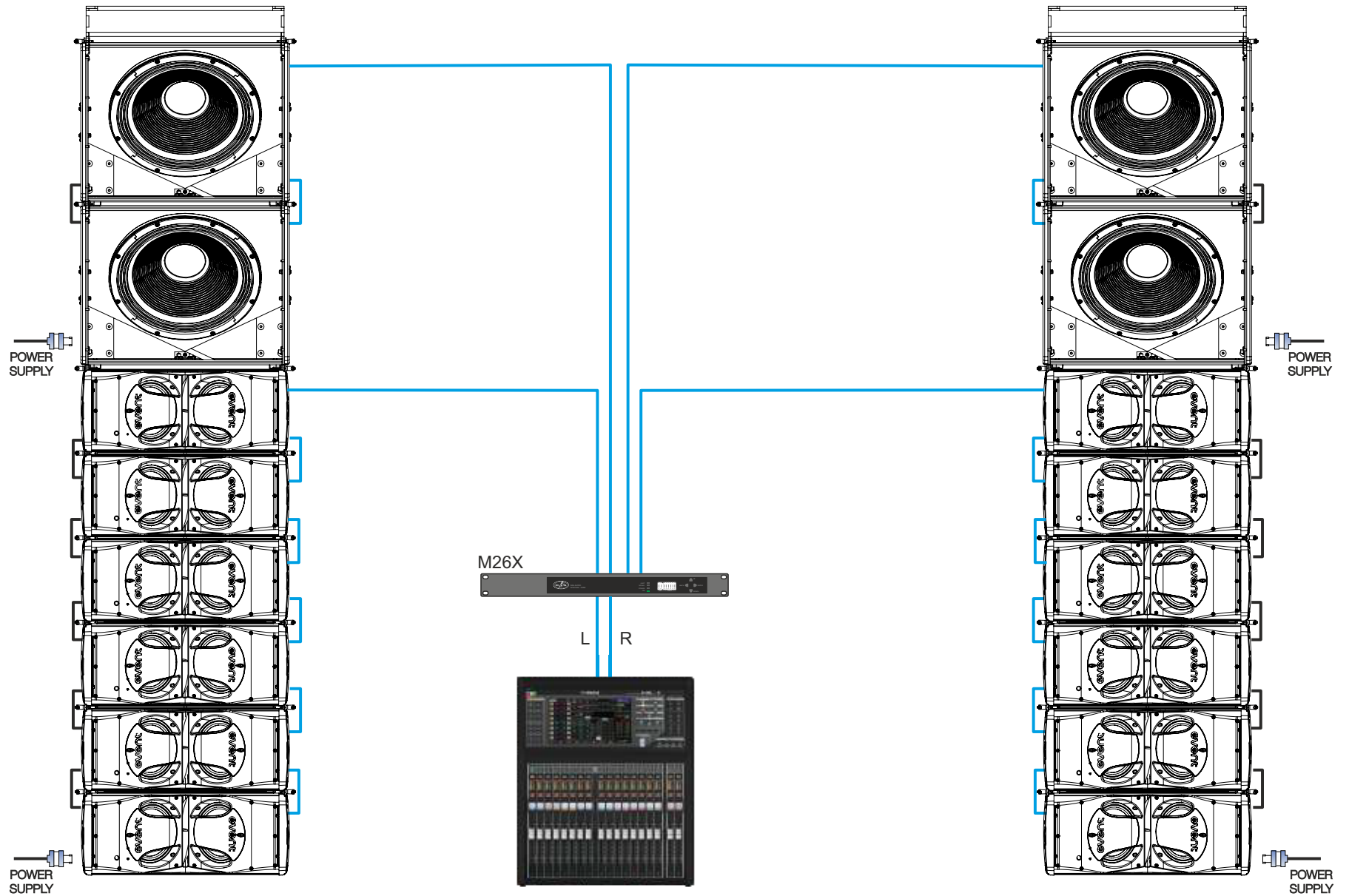

## Event Series | Specifications

Model	EVENT-28A	EVENT-118A
Nominal LF Power Amplifier	1000W peak - 500 W continuous Class D Amplifier	2000W peak - 1000 W continuous Class D Amplifier
Nominal HF Power Amplifier	300W peak - 150 W continuous Class D Amplifier	---
Input Type	Balanced Differential Line	Balanced Differential Line
Input Impedance	Line: 20 kohms	Line: 20 kohms
Sensitivity	Line: 6.2 V (+18 dBu)	Line: 1.95 V (+8 dBu)
Frequency Range (-10 dB)	70 Hz -20 kHz	35 Hz -125 Hz
Horizontal Coverage (-6dB)	100° Nominal	-
Vertical Coverage	Splay Dependent	-
Rated Maximum Peak SPL at 1 m <sup>(1)</sup>	133 dB	134 dB
Transducers/Replacement Parts	LF: 2 x 8MIN/ 8MIN HF: 1 x M-60/GM-M60N	LF: 1 x 18FWN/GM-18FW
Enclosure Geometry	Trapezoidal	Rectangular
Enclosure Material	Injected Polypropylene	Birch Plywood
Color/Finish	Black Polyurea Paint	Black Polyurea Paint
Rigging System Splay Angles	Integrated in box design	Integrated in box design
Connectors	INPUT: 1 x Female XLR LOOP THRU: 1 x Male XLR AC INPUT: 1 x powerCON NAC3FCA AC OUTPUT: 1 x powerCON NAC3FCB	INPUT: 1 x Female XLR LOOP THRU: 1 x Male XLR AC INPUT: 1 x powerCON NAC3FCA AC OUTPUT: 1 x powerCON NAC3FCB
AC Power Requirements	115 V, 2.4A, 50 Hz/60 Hz 230 V, 1.2A, 50 Hz/60 Hz	115 V, 4.2A, 50 Hz/60 Hz 230 V, 2.1A, 50 Hz/60 Hz
Dimensions (H x W x D)	280 x 635 x 525 mm 11.0 x 25.0 x 20.7 in	510 x 635 x 840 mm 20.0 x 25.0 x 33.0 in
Weight	20.5 kg (44.1 lb)	43.0 kg (94.8 lb)
Accessories	AX-EV28 Rigging System AXS-EV28 Stacking Base PL-EV28S Stacking Dolly JP-EV28 Joining plate AXC-ZT TRD-2 Tripod TRD-6 Extensible Pole Mount TRD-7 Extensible Pole Mount	AX-EV28 Rigging System AXS-EV28 Stacking Base PL-EV118S Stacking Dolly JP-EV28 Joining plate TRD-6 Extensible Pole Mount TRD-7 Extensible Pole Mount

**Event-28A**

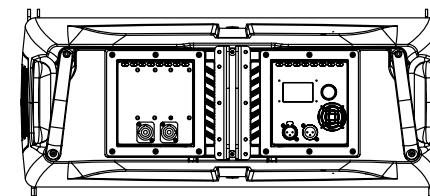
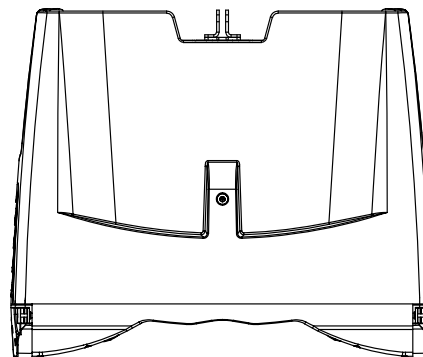
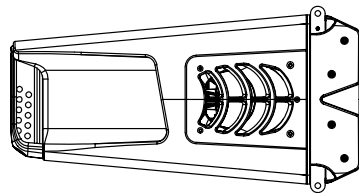
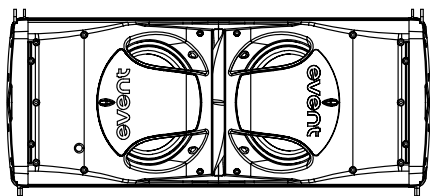

**Event-118A**

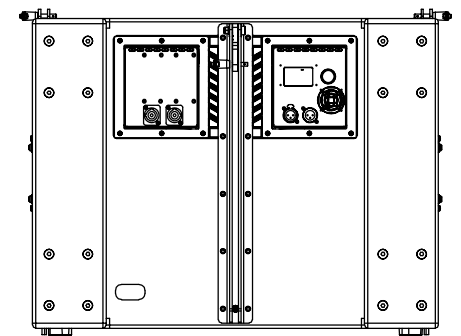
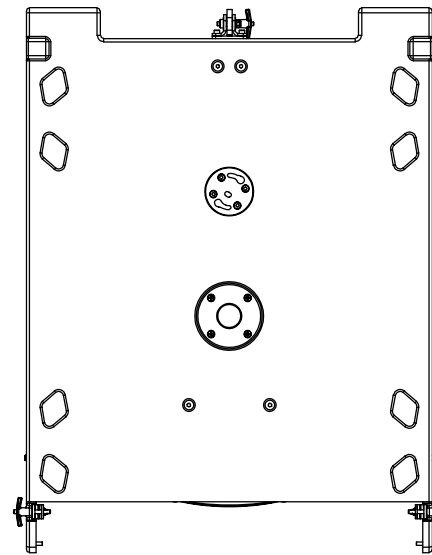
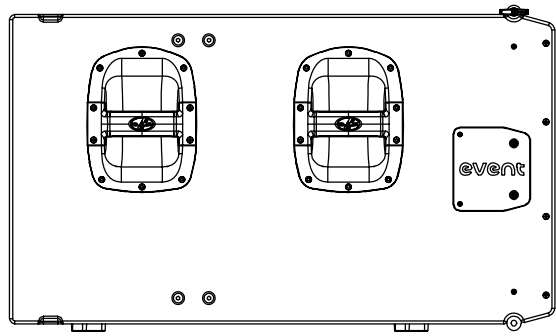
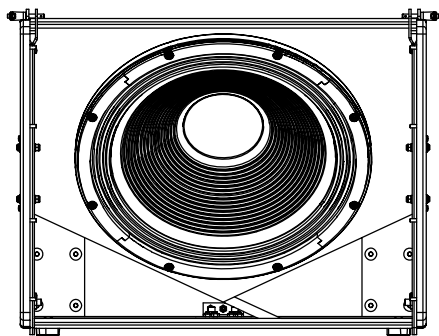

## Event Series | Amplifiers

### Event-28A Amplifier

#### 1. Input

XLR socket-type input signal connector. This is a balanced connector just like the OUTPUT connector with the following pin assignments:

1 or S =GND (ground) 2 or T =(+) Non inverted input 3 or R =(-) Inverted input

#### 2. Output:

XLR-type output signal connectors for connecting several units together and sending them all the same input signal (THRU).

#### 3. Display:

LIMIT / INPUT CLIP:

The signal's input level can be monitored in the LCD screen on the left meter. When the signal level is too high the Display will show "INPUT CLIP". Please reduce the level accordingly.

The output level with respect to the Limiter threshold can be monitored on the right meter. When the value reaches the limiter threshold the Display will show "LIMIT" (depending on the configuration mode the Display can be programmed to blink when the system is limiting).

SIGNAL:

The left meter indicates the presence of signal.

ON:

The Display will be illuminated when the system is on.

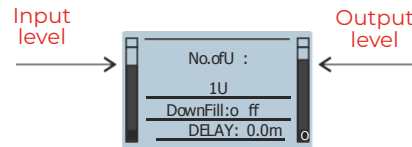

The background light of the display can be switched off permanently by selecting in the options / Dimming menu, the "dark" preset. This option will make the Display blink (on and off) when the system reaches its limit. This option may be useful in theaters or similar applications in order to reduce the visual contamination.

#### 4. ENCODER (DAScontrol):

Use the rotary encoder to navigate for preset selection (number of units, downfill) and options (reset, dimming etc).

## Event Series | Amplifiers

### 5. AC INPUT:

PowerCon NAC3FCA mains connector (inserted, rotated and locked for ON). Only use this equipment with an appropriate mains cord.

### 6. AC OUTPUT:

PowerCon NAC3FCB connector for AC loop thru (see unit's label)). Only use this equipment with an appropriate mains cord.

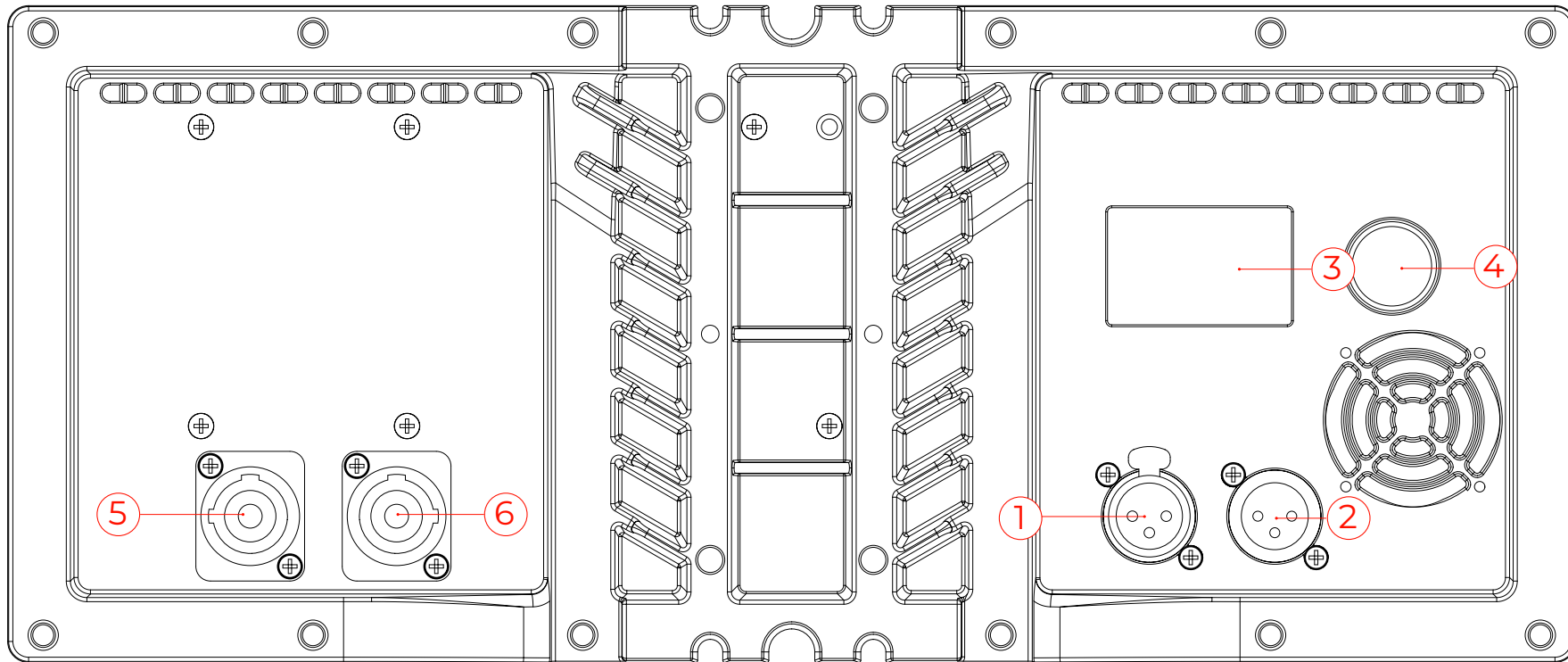

# Event Series | DAScontrol and display navigation

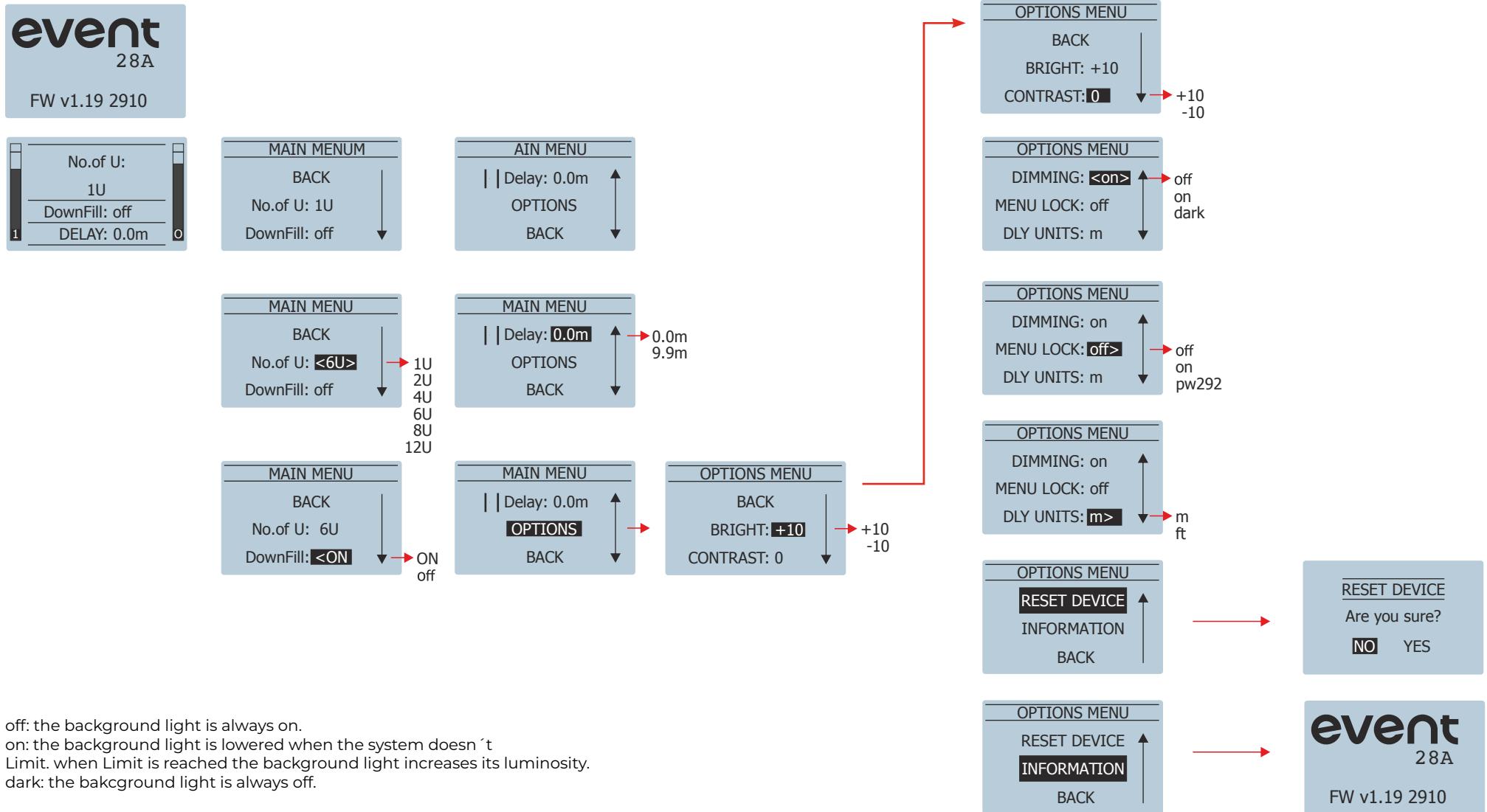

off: the background light is always on.  
 on: the background light is lowered when the system doesn't  
 Limit. when Limit is reached the background light increases its luminosity.  
 dark: the background light is always off.

# Event Series | DAScontrol and display navigation

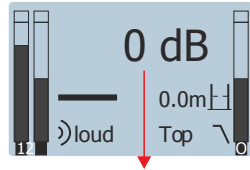

Level control: can be adjusted between MUTE (-60dB) and 0dB

Top: recommended when using the subwoofer with EVENT-28A

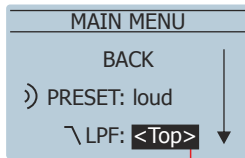
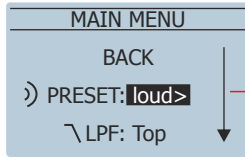
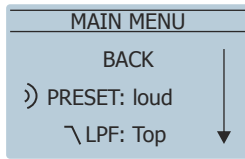

63Hz  
Top  
100Hz

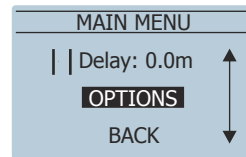
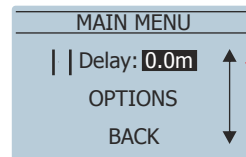
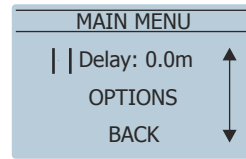

0.0m  
9.9m

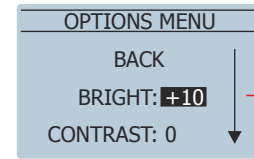

+10  
-10

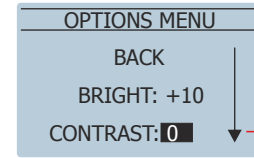

+10  
-10

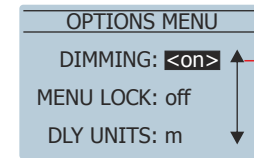

off  
on  
dark

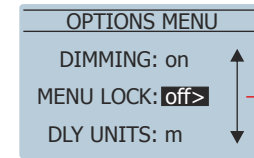

off  
on  
pw292

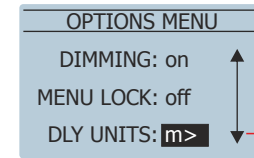

m  
ft

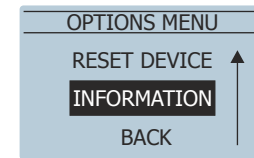
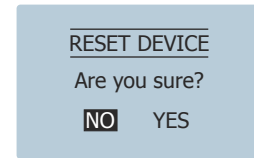
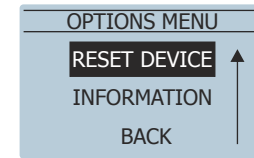

off: the background light is always on.  
on: the background light is lowered when the system doesn't Limit. when Limit is reached the background light increases its luminosity.  
dark: the background light is always off.

## Event Series | Recommendations of use

### ON / OFF

A sound system should be switched on sequentially. Switch on the self-powered units last in your sound system (switch on the subwoofer before the mid-high system). Switch on the sound sources such as CD players or turntables, then the mixer, then the processors, and finally the self-powered unit. If you have several units, it is recommended that you switch them on sequentially one at a time.

Follow the inverse order when switching off, turning self-powered units off before any other element in the sound system.

Disconnect the device by removing the mains connector from the mains socket. The mains connector and mains socket must always be freely accessible and never covered or blocked in any way.

The models use a power cable equipped with a Neutrik PowerCon NC3FCA connector. Power can be daisy chained via the NC3FCB output connector (see details on product label).

**IMPORTANT:** Do not disconnect the unit while in use. Ensure that the device is disconnected from the mains by observing that the display is turned off.

### Overload indicator (LIMIT / INPUT CLIP)

This device has an indicator (LIMIT / INPUT CLIP) that is shown on the display when the signal level is excessive.

The indicator should not be lit continuously. This distorts the signal (quickly fatiguing your ears) and may damage the speakers. Therefore, it is recommended that you never work with these two messages engaged; at most it should blink only occasionally.

### Equalisation

It is recommended the use of a computer based dual-channel FFT platform to view the frequency content of signals or measure the response of the entire electro-acoustic system, all to better make informed decisions about the deployment and operation of these systems.

The unit does not need extreme settings of equalisation to produce quality sound, just select the parameter “number of units” in the amplifier that corresponds to the amount of systems used and you will achieve a very good and balanced starting point before measuring and tuning the system.

Avoid high levels of gain on the equalisers. Gain values above +6 dB on a console's / processor's EQ are not recommended.

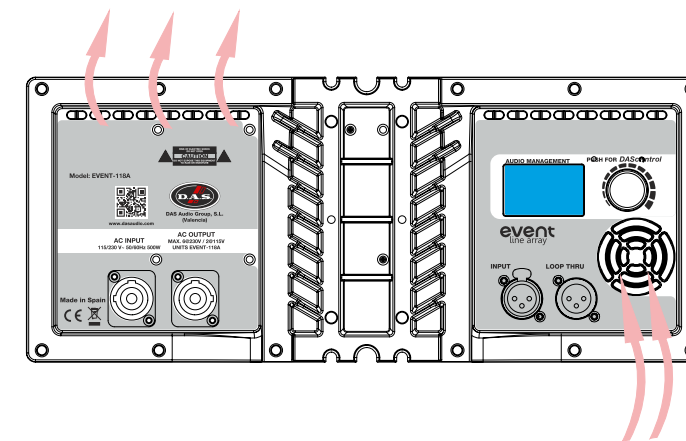
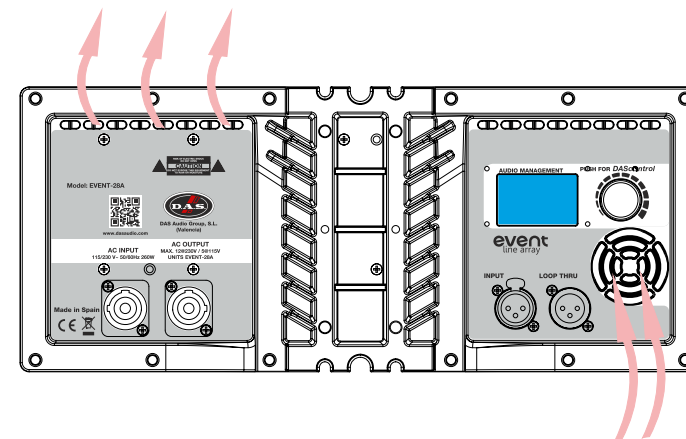

## Event Series | **Recommendations of use**

### **Overheating**

This equipment does not normally overheat during normal conditions of use. When overheating occurs, the FAN will automatically start working reducing the temperature of the unit. Make sure that the rain protectors are properly separated from the amplifier's back plate in order to not block the air flux thru the fan.

### **Low mains voltage**

If mains voltage falls below the shutdown voltage for the unit, it will stop playing, typically this value would be below 90Volts. When acceptable levels are regained, the unit will switch back on automatically.

Therefore the current consumed by a 115V version is double the 230V version to achieve the same acoustic power level.

<b>Pink Noise Mains 230 Vrms</b>	<b>EVENT-28A</b>	<b>EVENT-118A</b>
1/3 Power	1.2A	2.1A

## Event Series | Troubleshooting

Problem	Cause	Solution
<b>No sound from the unit. The DISPLAY does not light up.</b>	<ul style="list-style-type: none"> <li>1 - No power to the unit.</li> <li>2 - Defective cable / connector.</li> <li>3 - Defective amplifier.</li> </ul>	<ul style="list-style-type: none"> <li>1 - Check all the connections and the power distro.</li> <li>2 - Check that the cable and connector are working properly.</li> <li>3 - Contact with the dealer/tech support in the area.</li> </ul>
<b>Full power cannot be obtained. The LIMIT message is never displayed.</b>	<ul style="list-style-type: none"> <li>1 - The signal source does not have a hot enough output.</li> <li>2 - There could be some equalisations, filters or compressors applied in other devices (console, processor).</li> </ul>	<ul style="list-style-type: none"> <li>1 - If you use a mixer, be sure to use the balanced output if you have it. Use a professional mixer or signal source with more output level.</li> <li>2 - Double check the signal path and erase all Eqs, compressors applied.</li> </ul>
<b>Sound is distorted. The LIMIT message is not on, or only lights up occasionally but INPUT Clip is on.</b>	The mixer or signal source is distorting or it has excessive level.	Turn mixer channel gains down. Check that none of your signal sources are distorting.
<b>Sound is distorted and very loud and LIMIT message is shown.</b>	The system is overloaded and has reached maximum power.	Turn down the mixer's output.
<b>Hum or buzz when a mixer is connected to the unit.</b>	<ul style="list-style-type: none"> <li>1 - The console probably has un-balanced outputs. You may be using an incorrect un-balanced to balanced cable.</li> <li>2 - The mixer and the powered speaker are not plugged into the same mains outlet.</li> <li>3 - The audio signal cable is too long or too close to an AC cable</li> </ul>	<ul style="list-style-type: none"> <li>1 - Read the appendix of this manual to make a correct un-balanced to balanced cable.</li> <li>2 - Connect the mixer and the unit to the same mains outlet.</li> <li>3 - Use a cable that is as short as possible and/or move the audio signal cable away from mains cables.</li> </ul>
<b>Hum or buzz when using lighting controls in the same building.</b>	<ul style="list-style-type: none"> <li>1 - The audio signal cable is too long or too close to the lighting cable.</li> <li>2 - On a sound system with three-phase AC, the lighting equipment and the UNIT are connected to the same phase.</li> </ul>	<ul style="list-style-type: none"> <li>1 - Move the audio signal cable away from lighting cables. Try to find out at what point the noise is leaking into the system.</li> <li>2 - Connect the sound system to a different phase than the lights. You may need the help of an electrician.</li> </ul>
<b>The DISPLAY does not light up when the mains connector is connected and the unit is switched to ON.</b>	<ul style="list-style-type: none"> <li>1 - Bad or loose AC connection to the UNIT or the mains outlet.</li> <li>2 - Faulty AC cable.</li> <li>3 - Blown Fuse.</li> <li>4 - The mains voltage is out of range.</li> </ul>	<ul style="list-style-type: none"> <li>1 - Check your connections.</li> <li>2 - Check the cables, connectors and AC power with a suitable mains tester.</li> <li>3 - Replace the blown fuse for another of the same type and size. 4.- If the multimeter determines that the mains voltage is out the range, you may need the assistance of an electrician to find an appropriate solution.</li> </ul>



### Warning

This manual offers all the necessary information for flying or stacking EVENT Line Array series systems of DAS Audio. This information is illustrated with drawings and required safety precautions.

To any operations related to flying a system, read the present document first and act on the warnings and advice given. The goal is to allow the user to become familiar with the mechanical elements required to fly the acoustic system, as well as the safety measures to be taken during set-up and teardown.

Only experienced installers with adequate knowledge of the equipment and local safety regulations should fly speaker boxes. It is the user's responsibility to ensure that the systems to be flown (including flying accessories) comply with state and local regulations.

The working load limits in this manual are the results of tests by independent laboratories. It is the user's responsibility to follow and comply with safety factors, resistance values, periodical supervisions and warnings given in this manual. Product improvement by means of research and development is on going at DAS Audio Group, S.L. Specifications are subject to change without notice.

It is common practice to apply 5:1 safety factors for enclosures and static elements. For slings and elements exposed to material fatigue due to friction and load variation the following ratios must be met; 5:1 for steel cable slings; 4:1 for steel chain slings and 7:1 for polyester slings. Thus, an element with a breaking load limit of 1000 kg may be statically loaded with 200 kg (5:1 safety factor) and dynamically loaded with 142 kg (7:1 safety factor).

When a system is flying, the working load must be lower than the resistance of each individual flying point in the enclosure, as well as each box. Hanging hardware should be regularly inspected and suspect units replaced if in doubt. This is important to avoid injury and absolutely no risks should be taken in this respect. It is highly recommended that you implement an inspection and maintenance program on flying elements, including reports to be filled out by the personnel that will carry out the inspections. Local regulations may exist that, in case of accident, may require you to prevent evidence of inspection reports and corrective actions after defects were found.

Absolutely no risks should be taken with regards to public safety. When flying enclosures from ceiling support structures, extreme care should be taken to assure the load bearing capabilities of the structures so that the installation is absolutely safe. Do not fly enclosures from unsafe structures. Consult a certified professional if needed. All flying accessories that are not supplied by DAS Audio are the user's responsibility. Use at your own risk.

## Event Series | Rigging system

### 4 or 6 units mounting on a PL-EV28S flatbed dolly

Groups of four or six units are easy to transport by truck as we will see in this manual.

Once the packaging is removed, you can see four security locking pins on the rear enclosure's rigging system. These pins are going to be used to stack the cabinets; always use the pins of the unit to attach the one that is going to be located above it. The rigging system of the EVENT-28A employs a 3 point attaching system. Use two of the pins in the front left and right structures and the other two in the rear one.

The PL-EV28S includes 3 locking pins to stack the first unit.



**Warning:** For transport, introduce the pin in hole 1° at "Rear Link" in the first EVENT-28A



"Rear link" at 1°

Use 3 pins (PIN-6) of the PL-EV28S 2 at the front, one on each side

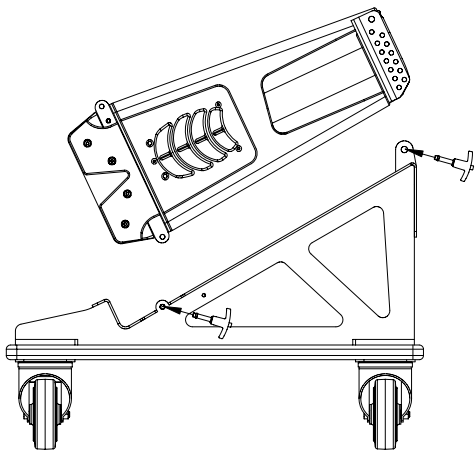

Fig. 1

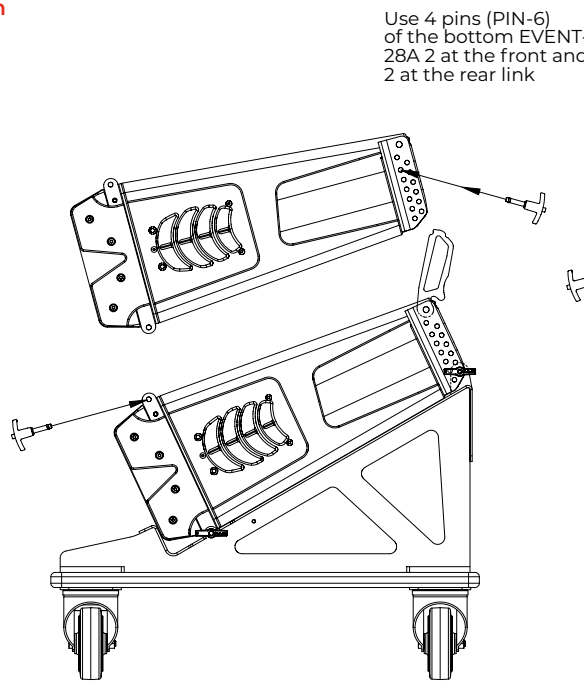

Fig. 2

Use 4 pins (PIN-6) of the bottom EVENT-28A 2 at the front and 2 at the rear link

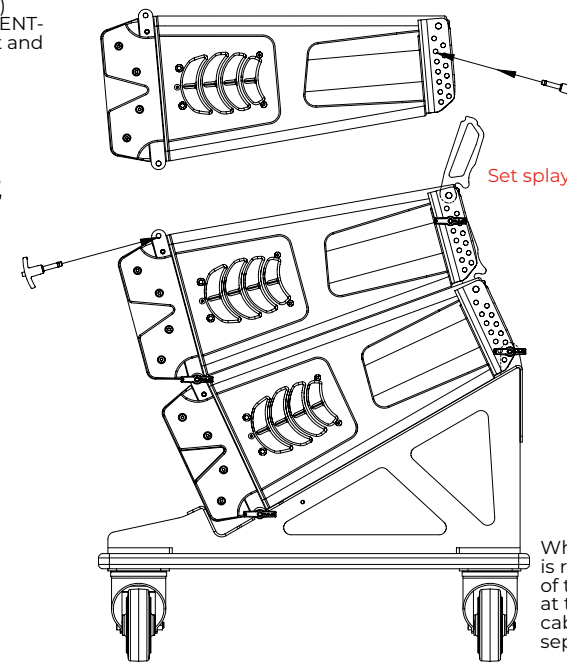

Fig. 3

The next figure shows the detail of the label located at the rear rigging structure of the EVENT-28A.

Splay angles vary from 0° to 10° in steps of 1°.

To secure (lock the movement) the systems when flying or stacking them, two pins are needed at the rear. One must be introduced in the "splay" angle hole, and the other in the "splay+1°" hole.

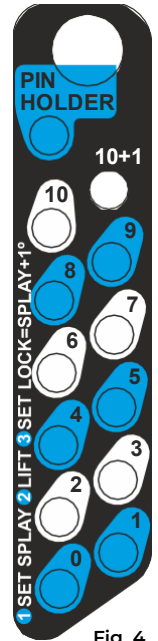

Fig. 4

When transporting the systems is recommended to insert one of the pins in the 10° splay angle at the rear. By doing this the cabinets wouldn't be able to get separated from the rear.

## Event Series | Rigging system

### 4 or 6 units mounting on a PL-EV28S flatbed dolly

Repeat the process shown in the previous figures with the rest of the cabinets. In this case, the set up of 4 units is shown.

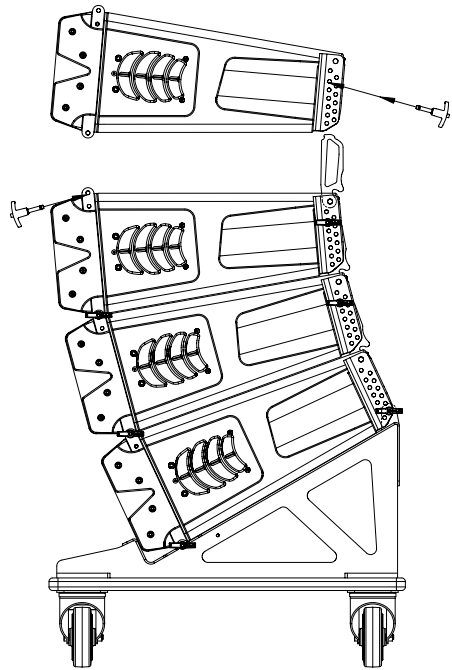

Fig. 5

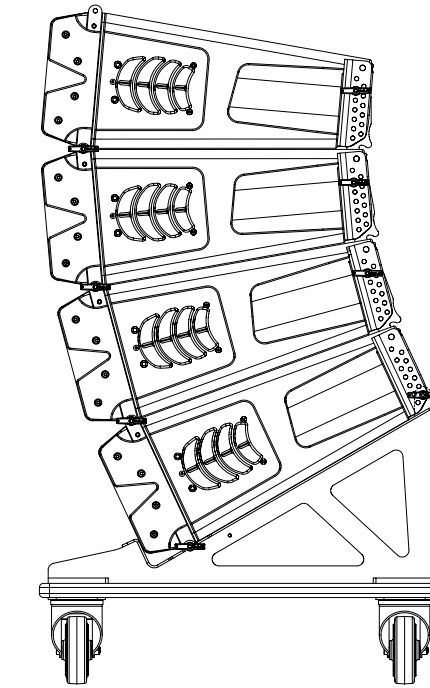

Fig. 6

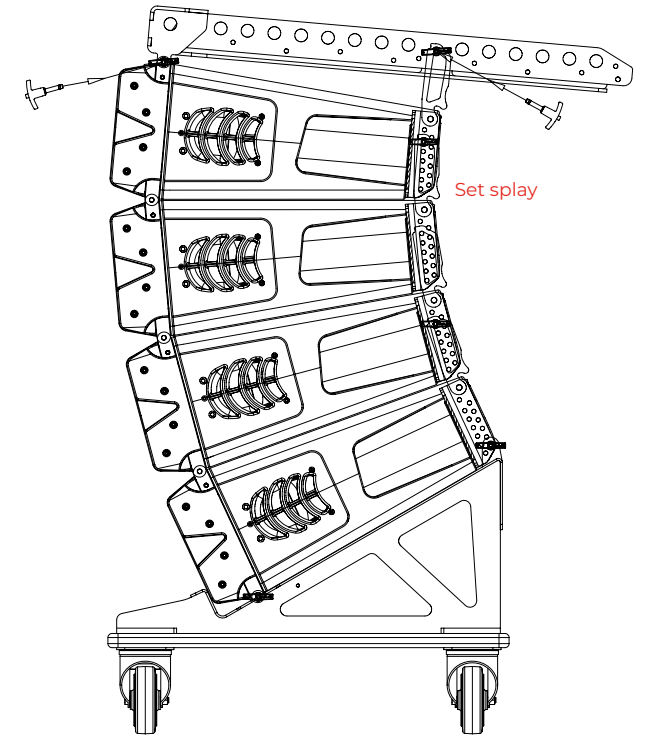

Fig. 7

Finally, the rigging bumper, AX-EV28 can be attached to the top cabinet using its available pins. Insert two pins at the front and one at the rear. Keep the extra pin stored in the cabinet.

At this point the cover for 4 units could be placed to protect them during transportation:

### Array mounting of groups of 4 units on a flatbed dolly

Groups of to 4 or 6 units are easy to transport by truck. We will see in this section the assembly of an array system with groups of four units previously placed on the PL-EV28S dollies.

The first group with 4 units will be the superior group, that is to say, the group where we will install the AX-EV28. To assembly the AX-EV28, first, remove the cover from the stack and use the pins of the top cabinet. Insert the pins of the top cabinet in the dedicated holes of the AX-EV28, as shown in the figure 8 (3 pins are needed). Next step would be running an Ease Focus simulation in order to know the different splay angles between the units and the pick up

position. (pin point of the central bar).

Before attaching the chain hoist to the AX-EV28, the user should be able to vary the splay angles between units and modify them accordingly to the Ease Focus 3 simulation. Set the splay angles between the units accordingly to the Ease Focus Project. In this case  $0^\circ$ ,  $2^\circ$  and  $4^\circ$ .

Fix the shackle in the pin point hole of the AX-EV28 determined by the Ease Focus 3 project and remove the pins that attach the bottom cabinet to the dolly before lifting the system.



**Warning: Verify the correct installation of the security pins. These pins will support the inferior load.**

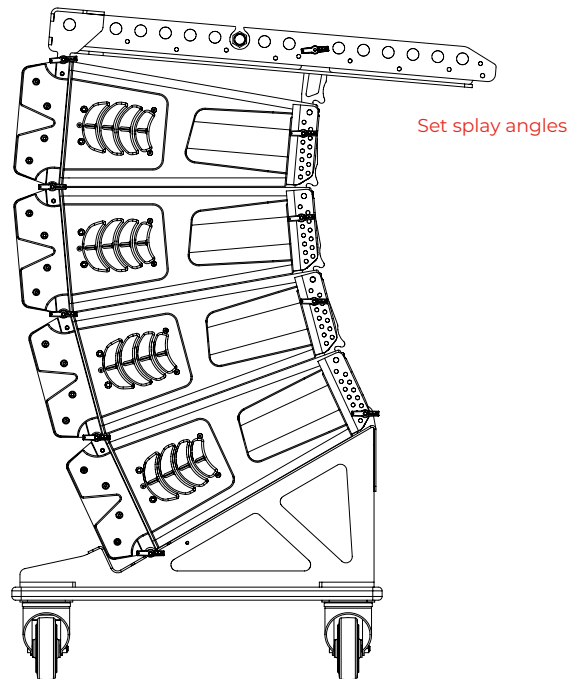

Fig. 8

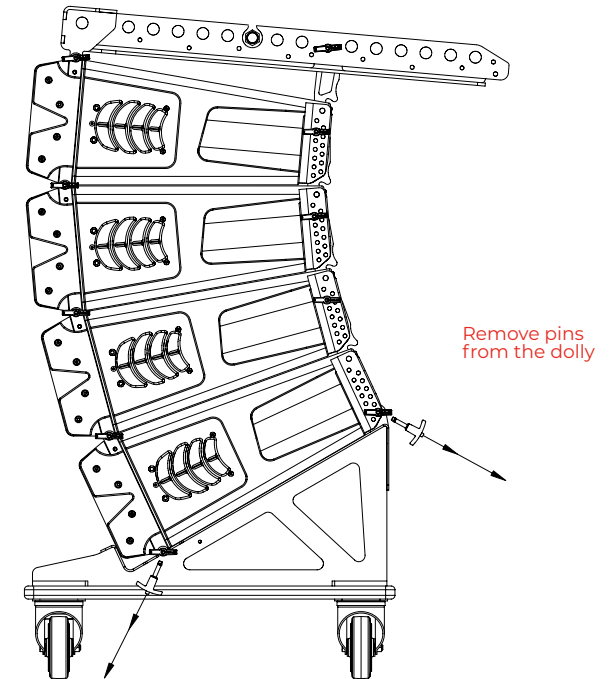

Fig. 9

## Event Series | Rigging system

Rise the system and splay angles between cabinet will be set automatically:

**NOTE:** To rig the system the simplest approach is using three pins (two at the front and one at the rear). With this method the splay angle between units is set automatically while the cabinets are lifted up.

If the user needs to lock the splay angle between the units, an extra pin (pin number 4), has to be inserted in the rear structure in hole named "splay+1°".

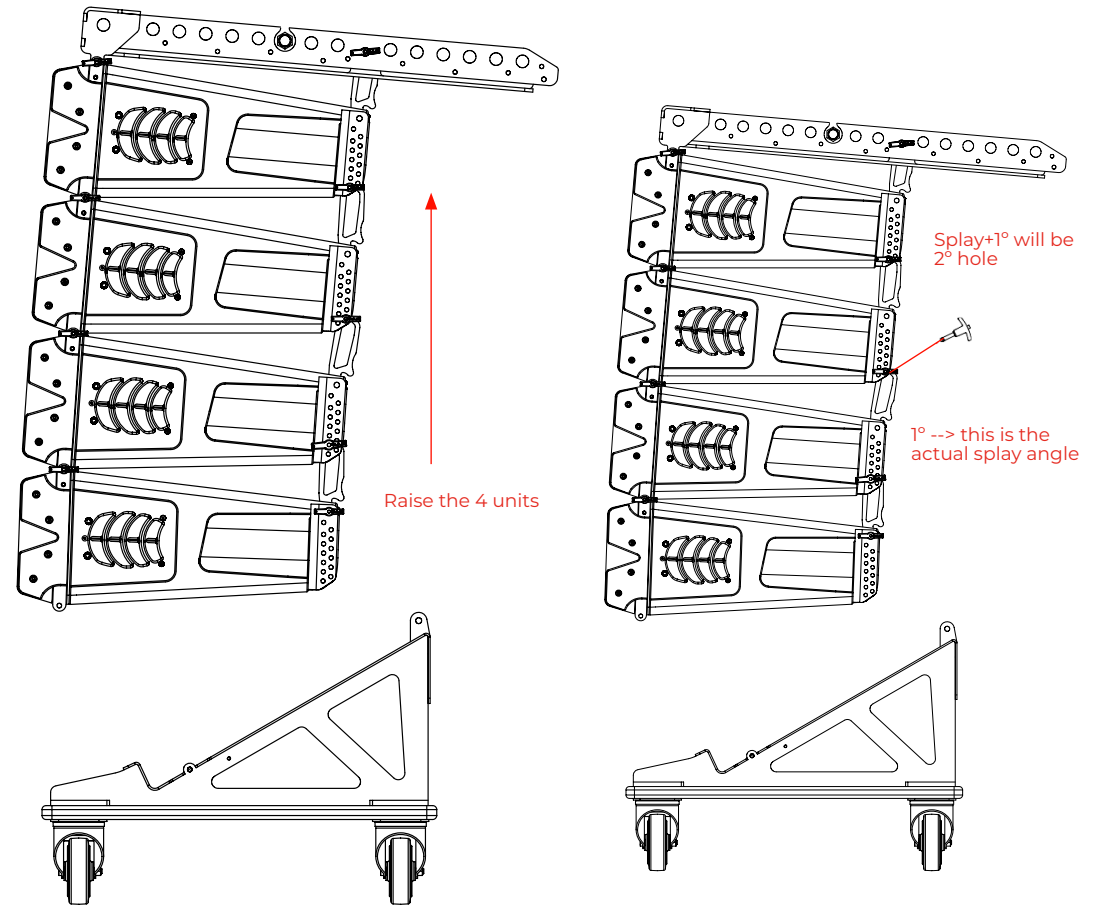

Fig. 10

## Event Series | Rigging system

Repeat the process with the second dolly. Lower the first four units, set splay angle in the ones stacked on the dolly, attach the two groups and rise it. In the sample shown only three pins per cabinet are used:

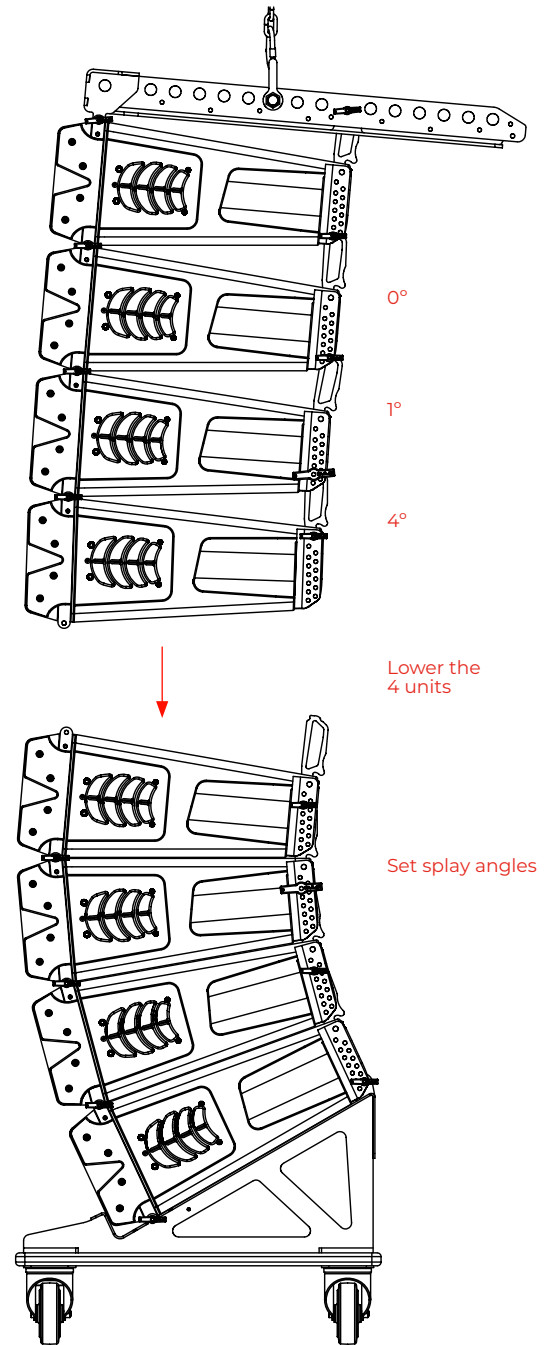

Fig. 11

EVENT-118A Array mounting

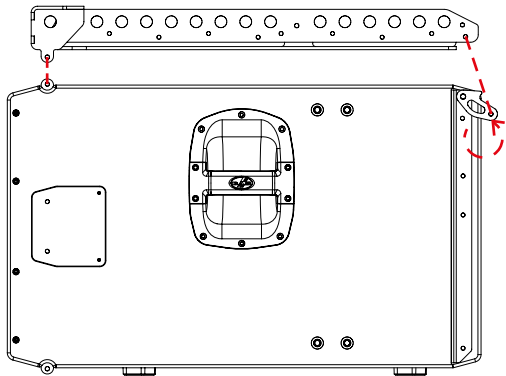

Fig. 12

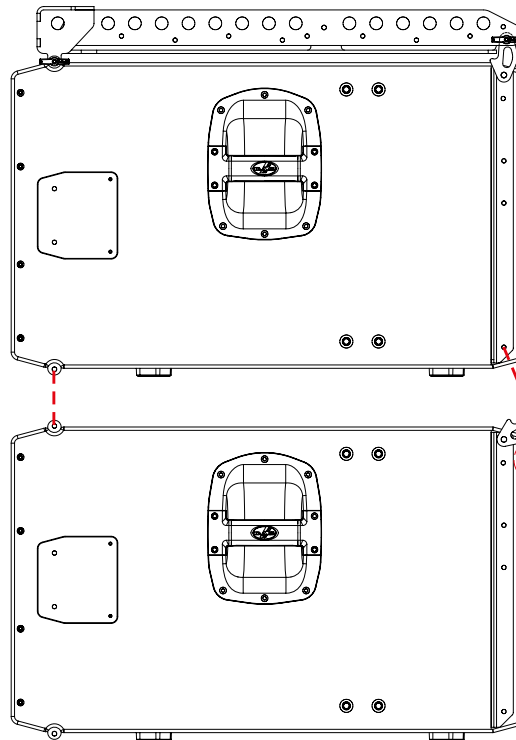

Fig. 14

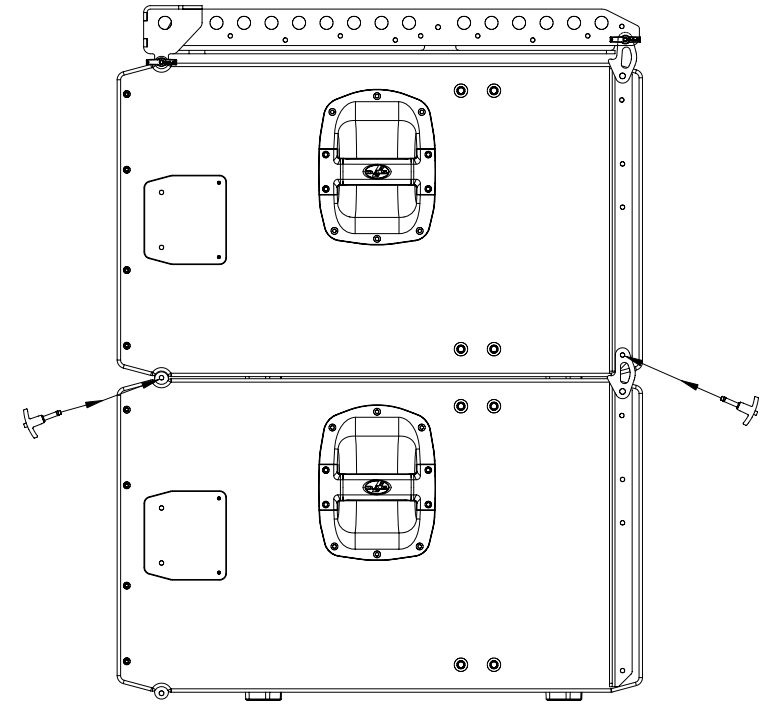

Fig. 15

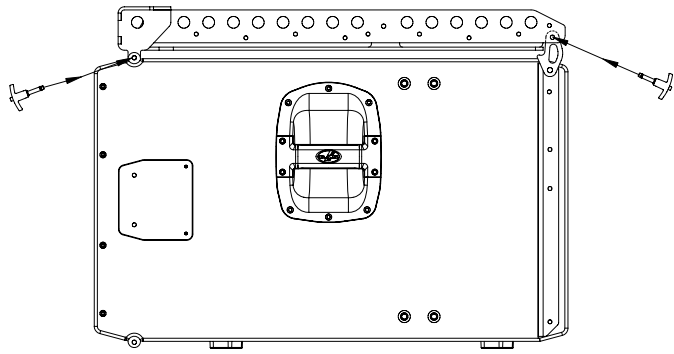
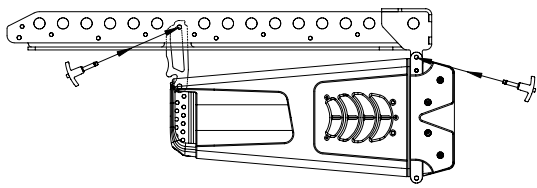

Fig. 13

EVENT-28A Array mounting "one by one"



Set splay

Fig. 16

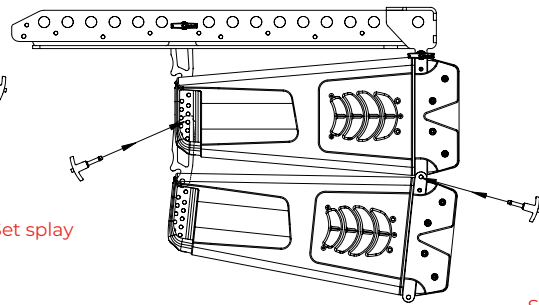

Set splay

Fig. 17

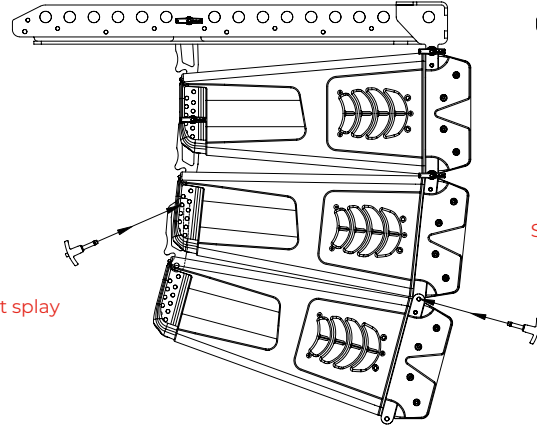

Set splay

Fig. 18

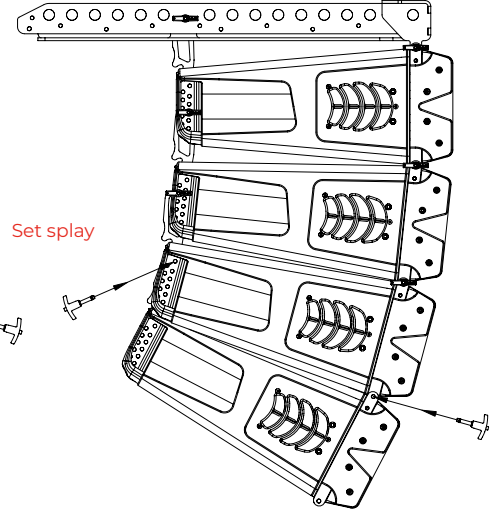

Fig. 19

### EVENT-118A + EVENT-28A Array mounting

First step will be assembling the subwoofers with the AX-EV28. follow the process shown on previous pages.

Next step, before hanging the EVENT-28A units is to fix to the bottom EVENT-118A the joining plate JP-EV28.

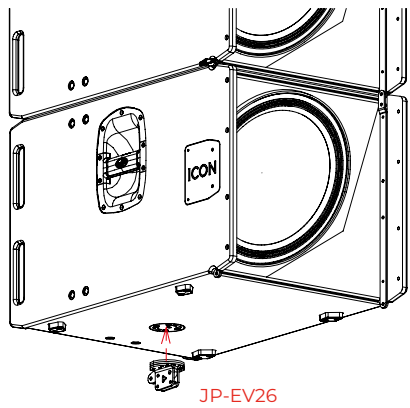

Fig. 20

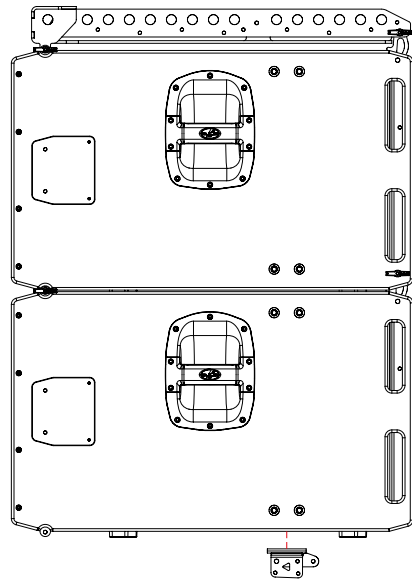

Fig. 21

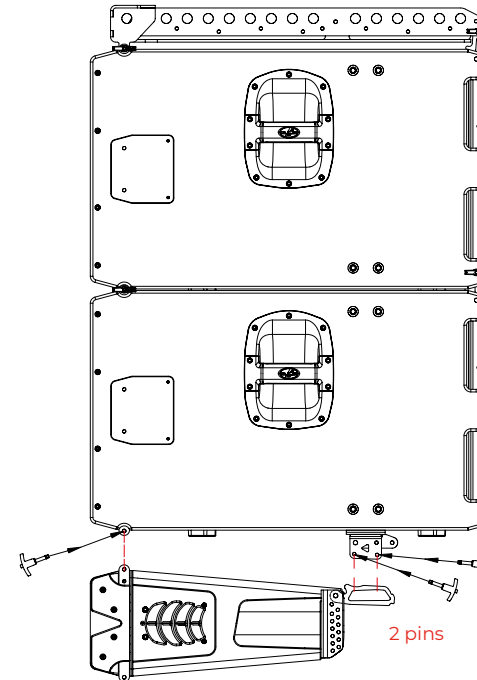

Fig. 22

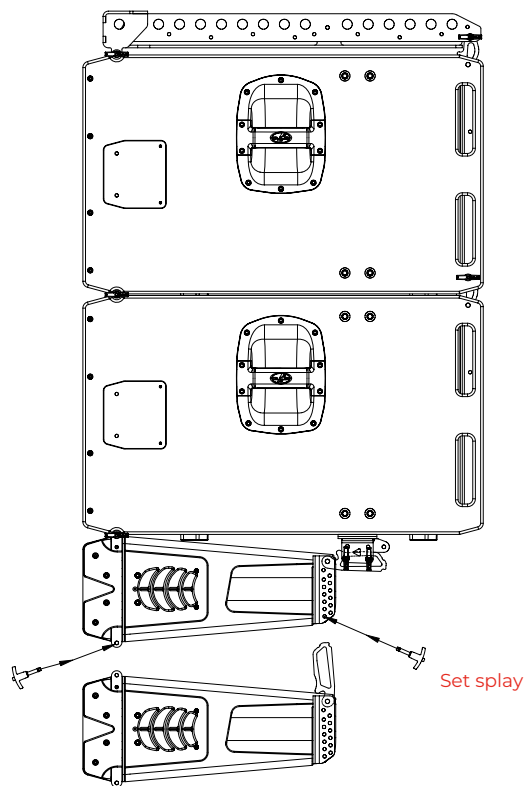

Fig. 23

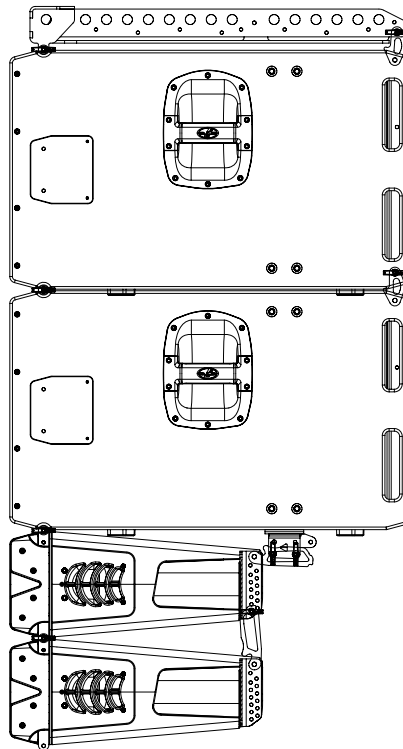

Fig. 24

**Stacking EVENT-28A on EVENT-118A**

JP-EV28 joining plate is needed to stack the systems.

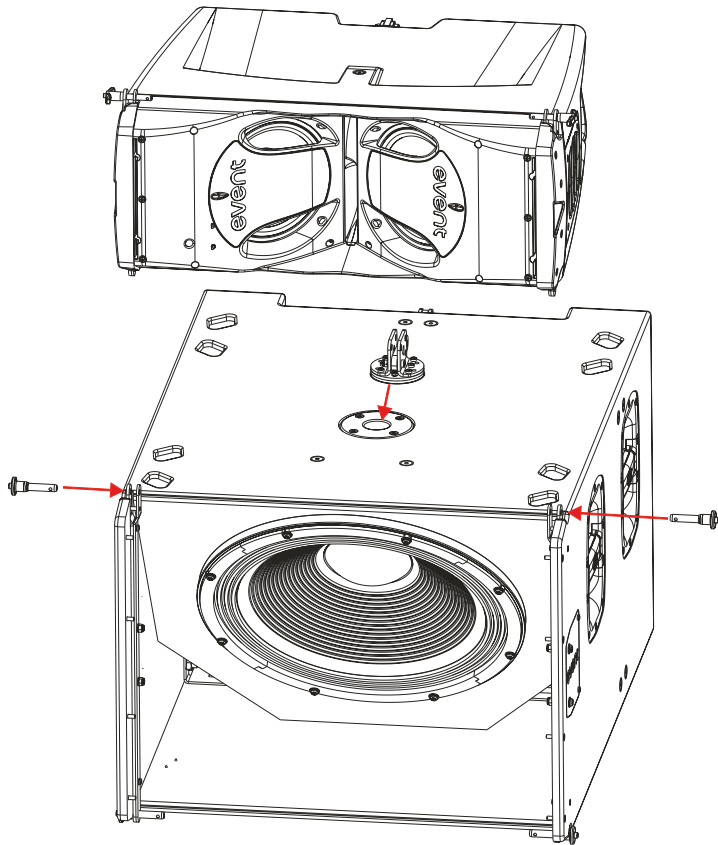

Fig. 25

Fig. 26

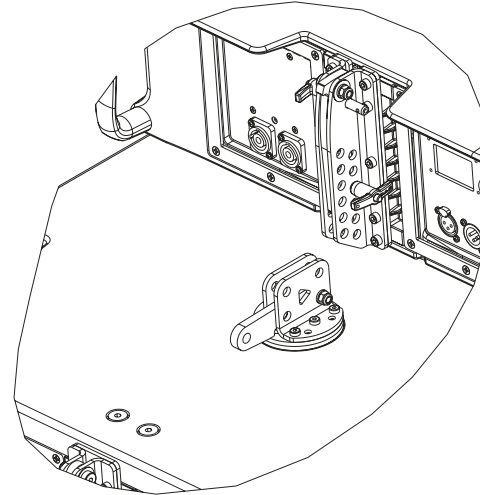
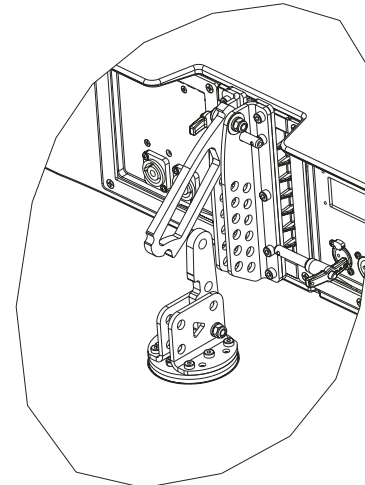

Fig. 27



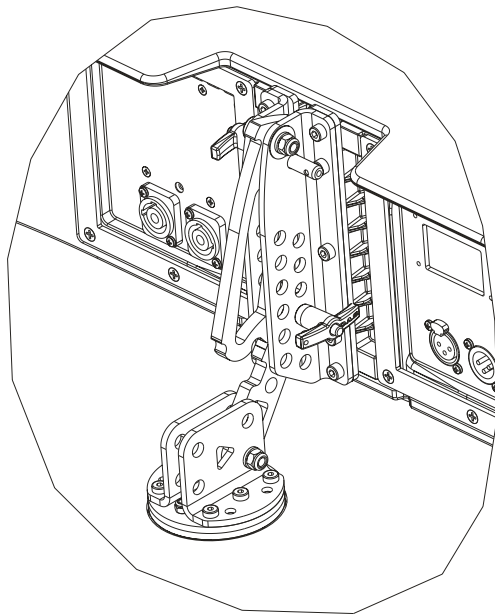

Fig. 28

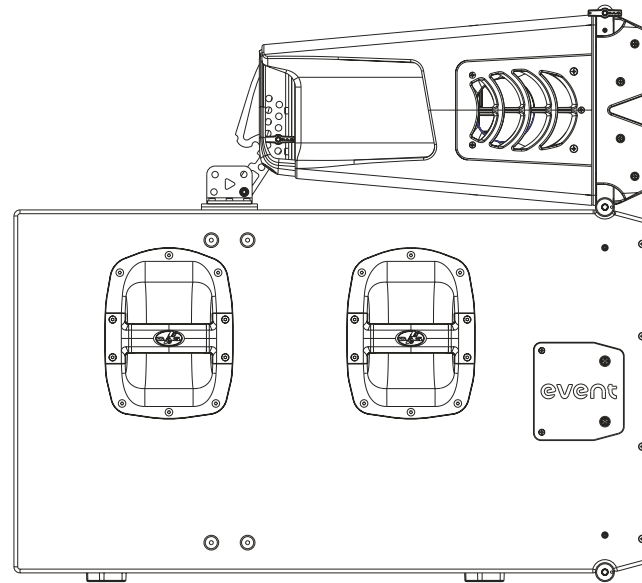

Fig. 29

**Angle between first EVENT-26A and EVENT-115A:**

Cam link Hole - real splay angle

- 9°= +4°
- 8°= +4°
- 7°= +2°
- 6°= +2°
- 5°= 0°
- 4°= 0°
- 3°= -2°
- 2°= -2°
- 1°= -3°
- 0°= -3°

## Stacking EVENT-28A on AXS-EV28

When using the AXS-EV28 to stack the system on a tripod TRD-2 or TRD-7 pole mount, AXC-ZT accessory is also needed.

First step, fix the EVENT-28A to the AXS-EV28

Next, fix the AXC-ZT to the AXS-EV28

When using the AXS-EV28 to stack the system on a EVENT-118A, AXC-ZT accessory is also needed.

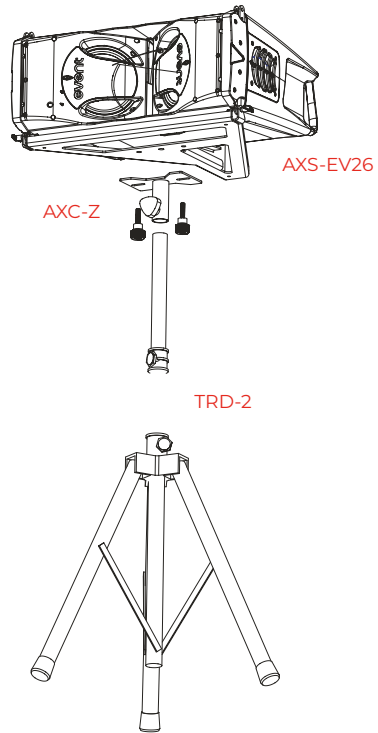

Fig. 30

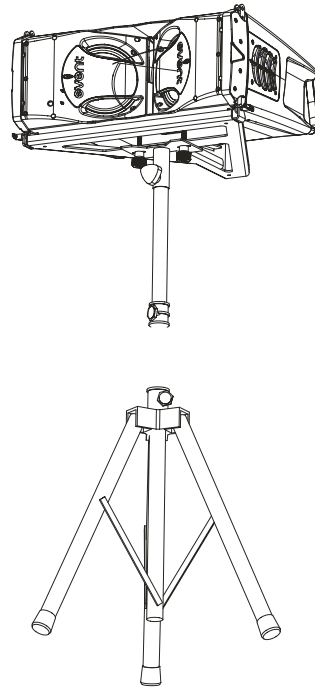

Fig. 31

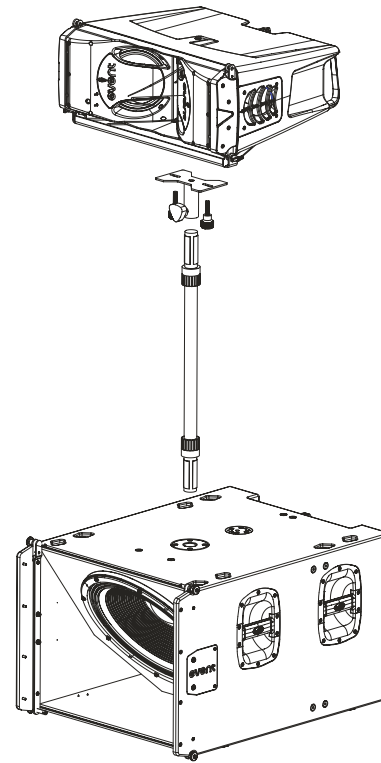

Fig. 32

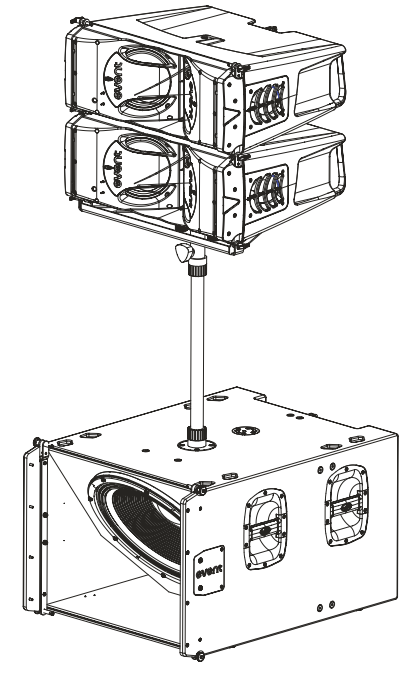
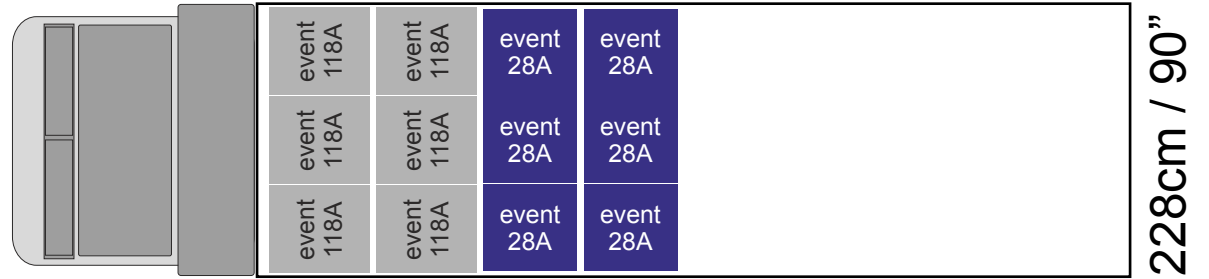
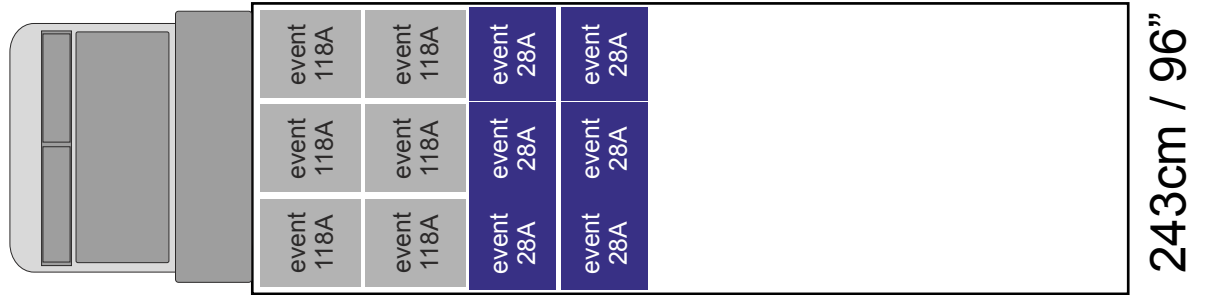

Fig. 33

## Event Series | **Transport**

As a compact system, tops and subs can be transported:



**Line connections: unbalanced and balanced**

There are two basic ways to transport an audio signal with microphone or line level:

**Unbalanced line:** Utilising a two conductor cable, it transports the signal as the voltage between them. Electromagnetic interference can get added to the signal as undesired noise. Connectors that carry unbalanced signals have two pins, such as RCA (Phono) and 1/4" (6.35mm, often referred to as jack) mono. 3 pin connector such as XLR (Cannon) may also carry unbalanced signals if one of the pins is unused.

**Balanced line:** Utilising a three conductor cable, one of them acts as a shield against electromagnetic noise and is the ground conductor. The other two have the same voltage with respect to the ground conductor but with opposite signs. The noise that cannot be rejected by the shield affects both signal conductors in the same way. At the device's input the two signals get summed with opposite sign, so that noise is cancelled out while the programme signal doubles in level. Most professional audio devices use balanced inputs and outputs. Connectors that can carry balanced signal have three pins, such as XLR (Cannon) and 1/4" (6.35mm) stereo.

The graphs that follow show the recommended connection with different types of connectors to balanced processor or amplifier inputs. The connectors on the left-hand side come from a signal source, and the ones on the right hand side go to the inputs of the processor or amplifier. Note that on the unbalanced connectors on the left-hand side, two terminals are joined inside the connector. If hum occurs with balanced to balanced connections, try disconnecting the sleeve (ground) on the input connector. Note that the illustrations show what should be connected to what, but that pin locations on an actual XLR connector are different. Also, pin 2 hot is assumed on XLR connectors.

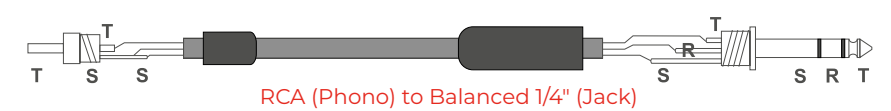
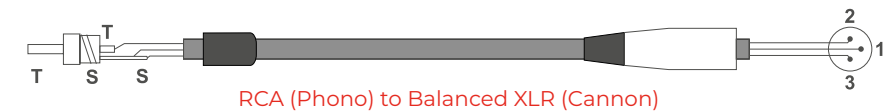
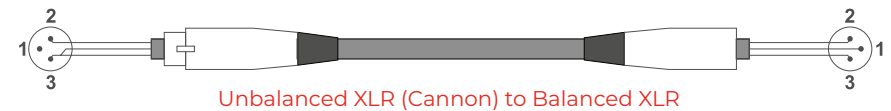





SOUND WITH SOUL

**DAS Audio Group, S.L.**

C/ Islas Baleares, 24  
46988. Fuente del Jarro  
Valencia - Spanien  
Tel. +34 961 340 860

**DAS do Brasil Ltd.**

Rua Dos Andradas, 382 SL  
Santa Efigênia, São Paulo  
Brasilien. CEP: 01208-000  
Tel. +551133330764

**DAS Audio of America, Inc.**

6900 NW 52nd Street Miami, FL  
33166 – U.S.A  
Tel. +1 305-436-0521

**DAS Audio China**

Han Kou Road 309, Room 302  
Huang Pu District  
上海市黄浦区汉口路309号302室  
200001 – Shanghai – China  
Tel. +86 21 5169 0869

**DAS Audio Asia PTE. LTD.**

9 Gray Lane 03-01  
Signature Crest  
Singapore 438951  
Tel. +65-9739-5000

**DAS Audio GmbH**

Mülheimer Str. 48  
53840 Troisdorf  
Germany  
Tel. +49 2241 945880



SOUND WITH SOUL

[www.dasaudio.com](http://www.dasaudio.com)