

EVENT-30A | EVENT-S218A

event
line array

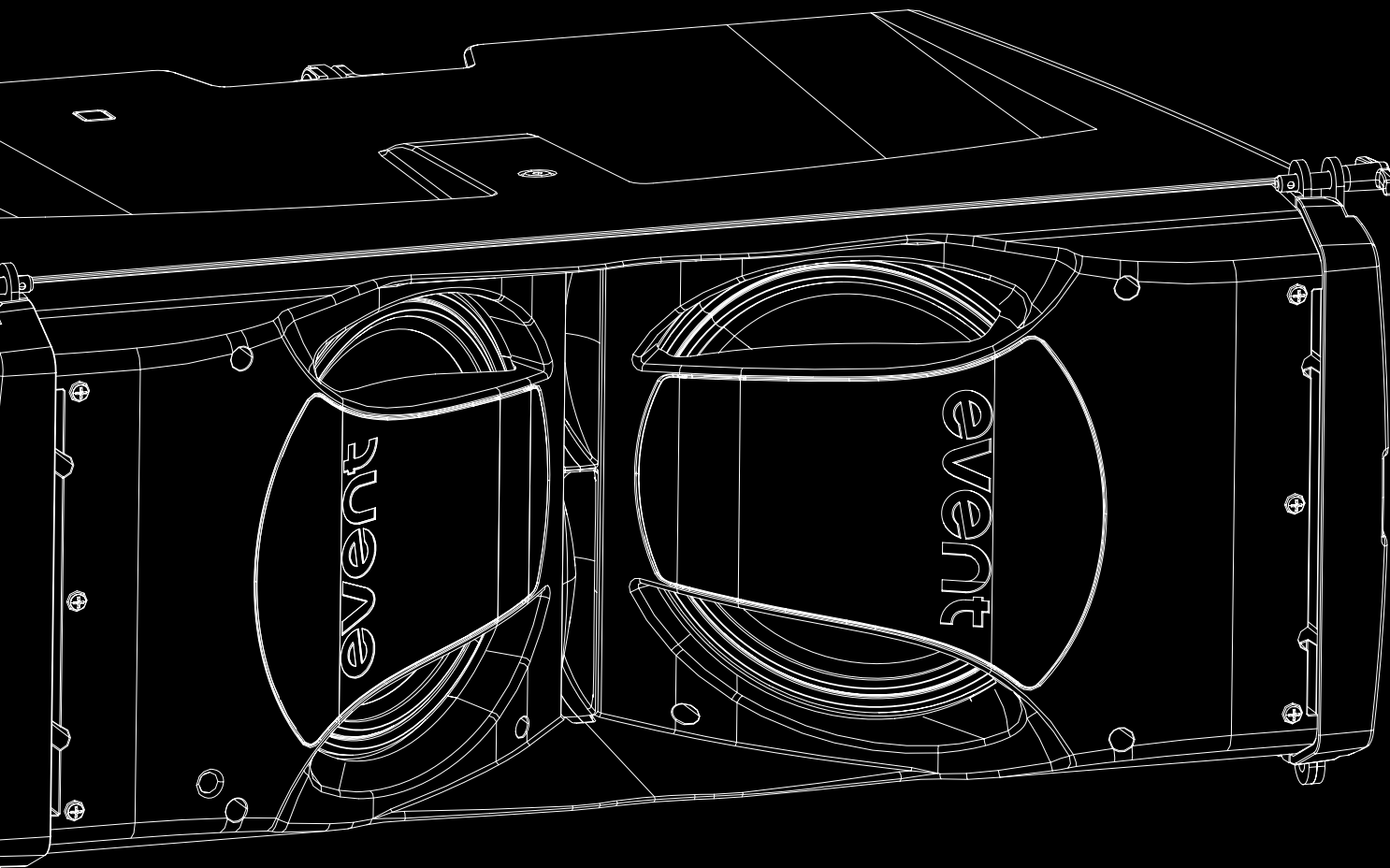

 **DAS AUDIO**

www.dasaudio.com



Before operating the device, please read the “Safety precautions” section of this manual.

Retain this manual for future reference.

Safety precautions	4
Declaration of conformity	5
Warranty	6
Introduction	7
System Configurations	9
Technical Specifications	14
Line drawing	15
Amplifiers	17
Amplifiers	
DAScontrol and Display Navigation	
Operating Recommendations	
Self Tuning	24
Firmware Update	28
Troubleshooting	30
Rigging	31
Assembly on PL-EV30S transport doll	32
Array assembly — groups of 4 units	34
EVENT-30A — cabinet to cabinet	36
EVENT-S218A transport dolly assembly	37
Mounting with AXS-EV30	38
Transport	39
Appendix	
Line Connections: unbalanced and balanced	40

Safety precautions

The exclamation point inside an equilateral triangle is intended to alert the users to the presence of important operating and maintenance (servicing) instructions in the literature accompanying the product. Heed all warnings. Follow all instructions. Keep these instructions.

WARNING: This is a class A product. In a domestic environment this product may cause radio interferences in which case the user may be required to take adequate measures.

Use this product only in E1, E2, E3 or E4 environments according to EN55103-2.

Do not remove mains connector ground, it is dangerous and illegal. Class I device. The product must be connected to a mains socket outlet with protective earth connection. Only use this equipment with an appropriate mains cord for your country.

The lightning and arrowhead symbol warns about the presence of uninsulated dangerous voltage. To reduce the risk of electric shock, do not remove the cover.

Do not install near any heat sources such as radiators, heat registers, stoves or other apparatus that produce heat. The circulation of air through the heatsink must not be blocked.

Do not expose this device to rain or moisture. Do not use this apparatus near water (for example, swimming pools and fountains). Do not place any objects containing liquids, such as bottles or glasses, on the top of the unit. Do not splash liquids on the unit. IP-43 equipment.

This symbol on the product indicates that this product should not be treated as household waste. Instead it shall be handed over to the applicable collection point for the recycling of electrical and electronic equipment.

Working temperature ranges from 15°C to 45°C with a relative humidity of 95%, with ±10% of the rated main voltage value indicated on the rear label. If the fuse needs to be replaced, please pay attention to correct type and ratings.



The outer wiring connected to the device requires installation by an instructed person or the use of a flexible cable already prepared.

If the apparatus is connected permanently, the electrical system of the building must incorporate a multipolar switch with a separation of contact of at least 3mm in each pole.

To disconnect the device, you should use the mains plug. Unplug this apparatus during lightning storms, earthquakes or when unused for long periods of time.

Do not place loudspeakers in proximity to devices sensitive to magnetic fields such as television monitors or data storage magnetic material.

For EVENT-30A, the maximum safety height from floor to bottom of enclosure when mounting on a TRD-2 tripod (it needs also AXS-EV30), with legs spread 55cm from the central pole, is:

1x EVENT-30A----- >142 cm

The appliance should be flown only from the rigging points and by qualified personnel. Do not suspend the box from the handles.

No user serviceable parts inside. Refer all servicing to qualified service personnel. Servicing is required when the apparatus has been damaged in any way, such as power-supply cord or plug is damaged, liquid has been spilled or objects have fallen into the apparatus, the apparatus has been exposed to rain or moisture, does not operate normally or has been dropped.

Clean only with a dry cloth. Do not use any solvent based cleaners.

Declaration of conformity

DAS Audio Group, S.L.

C/ Islas Baleares, 24 - 46988

Pol. Fuente del Jarro - Valencia. Spain

Declares that models EVENT-26A and EVENT-115A:

Abide by essential objectives relating Directives:

- | | |
|---|------------|
| · Low Voltage Directive | 2014/35/UE |
| · EMC Directive | 2014/30/UE |
| · RoHS Directive | 2011/65/UE |
| · WEEE Directive | 012/19/UE |
| · Commission Delegated Directive 2015/863/EU and amendments | |

In accordance with Harmonized European Norms:

- EN 62368-1:2020 + A11:2020 Audio/video, information and communication technology equipment - Part 1: Safety requirements
- EN 55032:2015 + A11:2020 + A1:2020 Electromagnetic compatibility of multimedia equipment. Emission requirements.
- EN 55035:2017 + A11:2020 Electromagnetic compatibility of multimedia equipment. Immunity requirements.
- EN IEC 63000:2018 Technical documentation for the assessment of electrical and electronic products with respect to the restriction of hazardous substances.

Warranty

All our products are warranted for a period of 24 months from the date of purchase.

The warranty excludes damage resulting from incorrect use of the product.

All warranty repairs must be carried out exclusively by the manufacturer or the authorized technical service.

To request a warranty repair, do not open the product or attempt to repair it.

All warranty details (including warranty extension) can be found in the SUPPORT section of our website: www.dasaudio.com

Introduction

EVENT-30A

The EVENT-30A is a compact, symmetrical, self-powered two-way line array system designed to deliver high acoustic performance with exceptional ease of use. Its reinforced polypropylene enclosure houses two 10" neodymium transducers and two M-60 (1.75") compression drivers coupled to a high-precision waveguide. The symmetrical "V" transducer configuration ensures consistent horizontal coverage of 90° down to 200 Hz, while the waveguide controls vertical dispersion and guarantees precise coupling between units in vertical arrays.

- » Compact lightweight self-powered line array
- » High-efficiency Class D amplifier with SMPS
- » Universal power supply for worldwide use
- » Self Tuning IR based auto adjustment tool
- » Easy configuration with DAScontrol™
- » 24-bit DSP with LCD display
- » FIR processing for flat-phase response
- » FSS™ Fast Set Splay for rapid angle adjustment
- » Wi-Fi connectivity for firmware updates

The EVENT-30A incorporates Smart Self Tuning, an intelligent alignment technology using infrared sensor detection. Each unit identifies its position in the array and automatically loads the appropriate presets (long throw / short throw), significantly reducing setup time.

Powered by a high-efficiency Class D amplifier with universal SMPS, the EVENT-30A delivers 2000 W peak power and a maximum linear SPL of 138 dB (AES75). FSS™ supports arrays of up to 24 units, with splay angle from 0° to 10° in 1° increments.

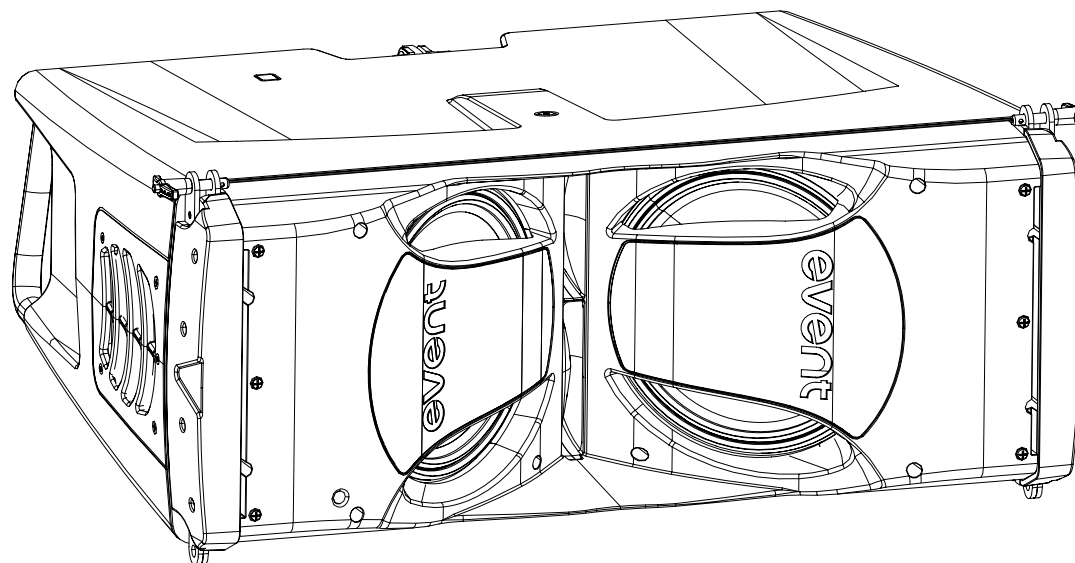

Its 24-bit DSP integrates FIR processing for flat-phase response and full compatibility with EVENT-26A and EVENT-28A. Combined with DAScontrol™, Smart Self-Tuning provides precise control and a streamlined workflow for touring and rental.

Designed to integrate with the EVENT-S218A subwoofer, the EVENT-30A forms a powerful full-range system. Weighing just 26.5 kg (58.4 lbs), it combines power, technology and portability for medium-to-large events, fixed installations and professional rental.

Introduction

EVENT-S218A

The EVENT-S218A is a high-performance self-powered subwoofer designed for professional applications, providing extended low-frequency output with high SPL and exceptional control. It features two 18" neodymium transducers (18ESN) with 4" dual-layer voice coils for increased power handling, reduced distortion, and improved thermal stability. The enclosure is made from multi-layer birch plywood with a black ISOFlex polyurea finish for durability and impact protection.

Integrated 4-channel bridged Class-D amplification delivers up to 4500 W peak power, while the DSP allows easy access to system parameters, cardioid configurations for 2 or 3 units, minimising rear sound radiation. Wi-Fi connectivity ensures firmware updates are simple and reliable.

The bass-reflex enclosure includes rubber feet on the base and side, and two M20 mounting points. The rigging system is fully compatible with the EVENT-30A, enabling fly or ground-stack configurations.

A pole socket on the upper panel allows the system to be used in combination with the EVENT-30A or other compatible full-range systems.

- » Self-powered dual 18" bass-reflex subwoofer
- » 2 × 18ESN neodymium transducers with 4" dual-layer voice coils
- » 4-channel bridged Class D amplifier with SMPS
- » Universal power supply for worldwide use
- » Easy configuration with DAScontrol™
- » Cardioid presets for 2 or 3 units
- » Wi-Fi connectivity for firmware updates
- » Dedicated Low Pass Filters for Event-26A, 28A and 30A

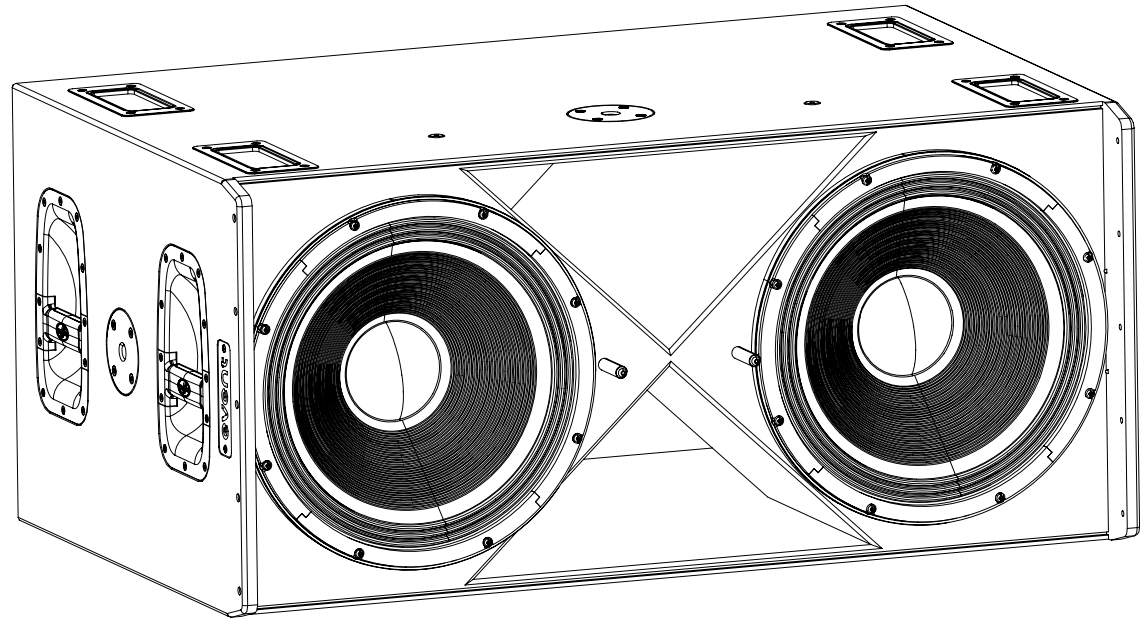

System Configurations

2 x EVENT-30A + 2 x EVENT-S218A

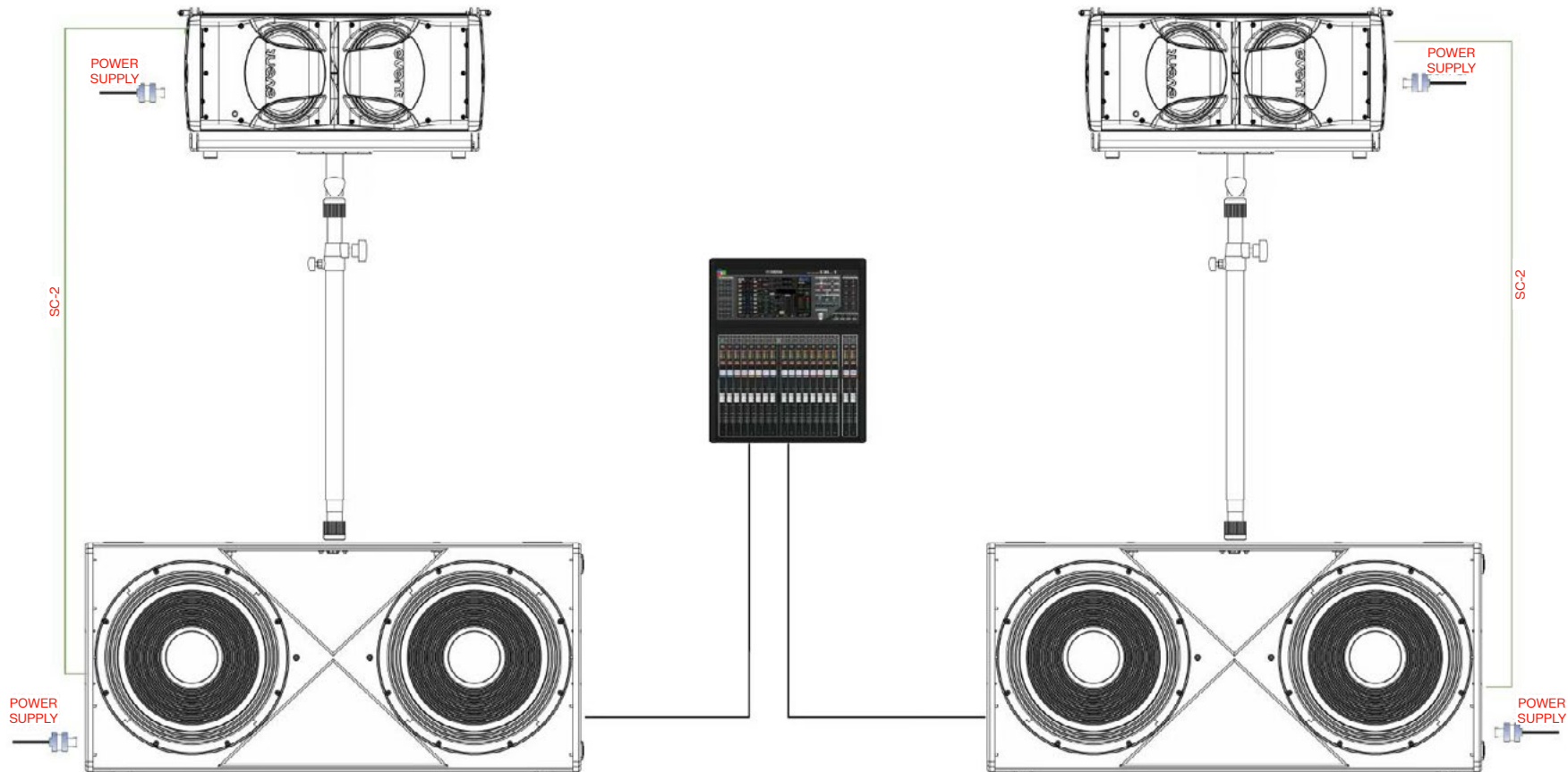

List of material

- 2 x SC-2
- 2 x AXS-EV30
- 2 x TRD-8
- 1 x PL-EVS218
- 1 x FUN-2-EVS218

System Configurations

8 x EVENT-30A + 4 x EVENT-S218A

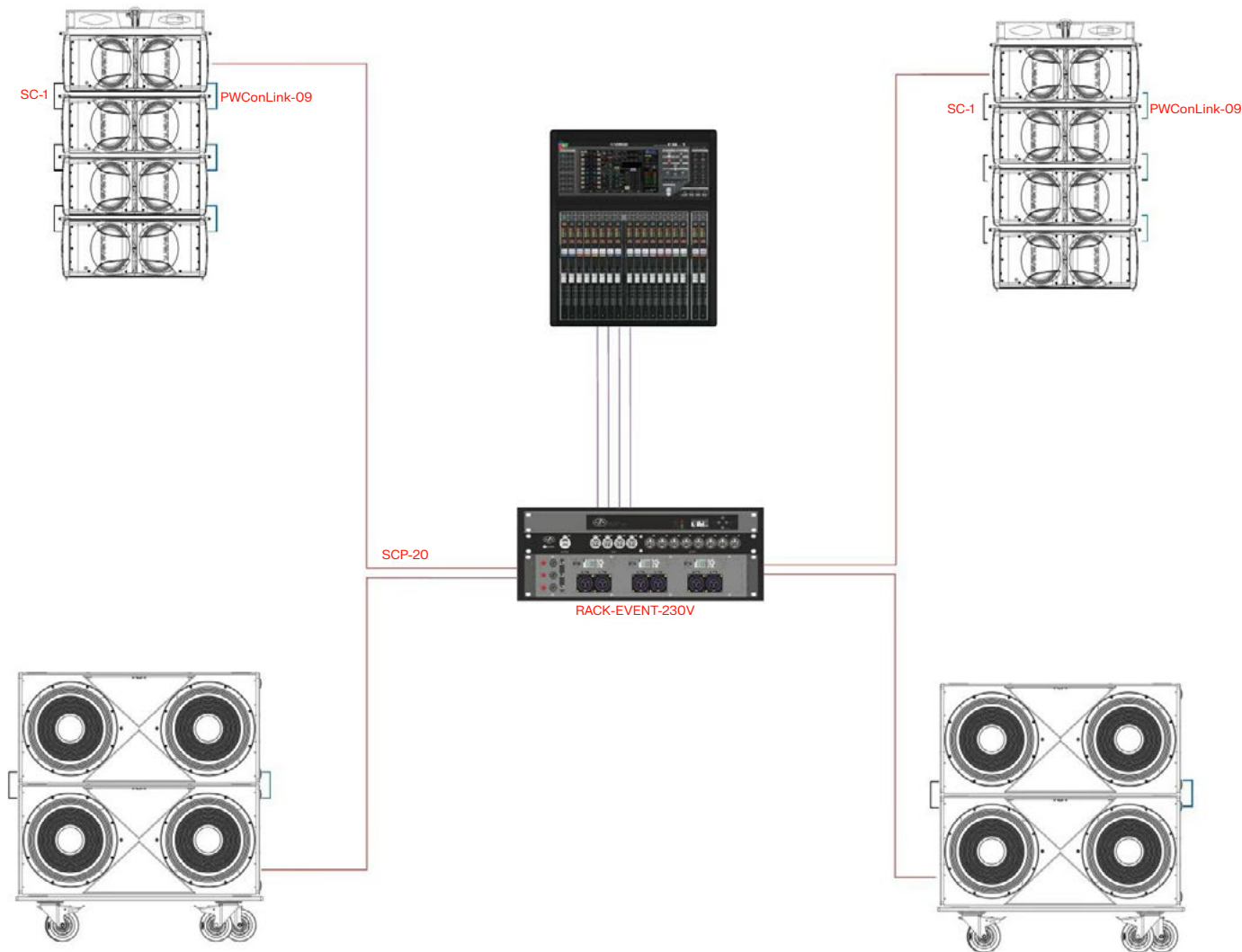

- List of material**
- 8 x PWCONLINK-09
 - 8 x SC-1
 - 4 x SCP-20
 - 2 x AX-EV30
 - 2 x PL-EV30S
 - 2 x FUN-4-EV30
 - 2 x PL-EVS218
 - 2 x FUN-2-EVS218
 - 1 x RACK-EVENT-230V

System Configurations

12 x EVENT-30A + 8 x EVENT-S218A

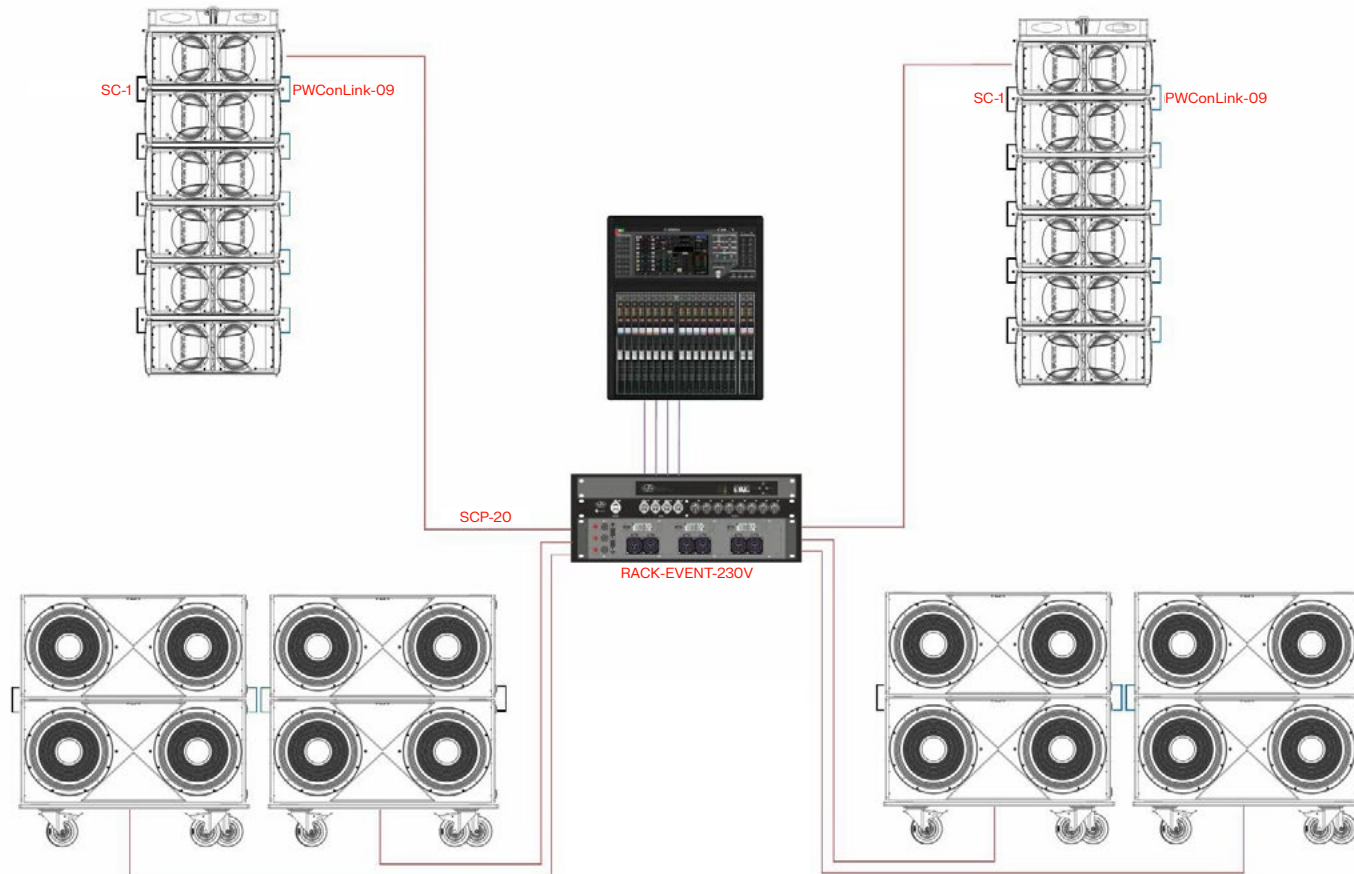

List of material

- 14 x PWCONLINK-09
- 14 x CS-1
- 6 x SCP-20
- 2 x AX-EV30
- 2 x PL-EV30S
- 2 x FUN-4-EV30
- 4 x PL-EVS218
- 4 x FUN-2-EVS218
- 1 x RACK-EVENT-230V

System Configurations

16 x EVENT-30A + 12 x EVENT-S218A

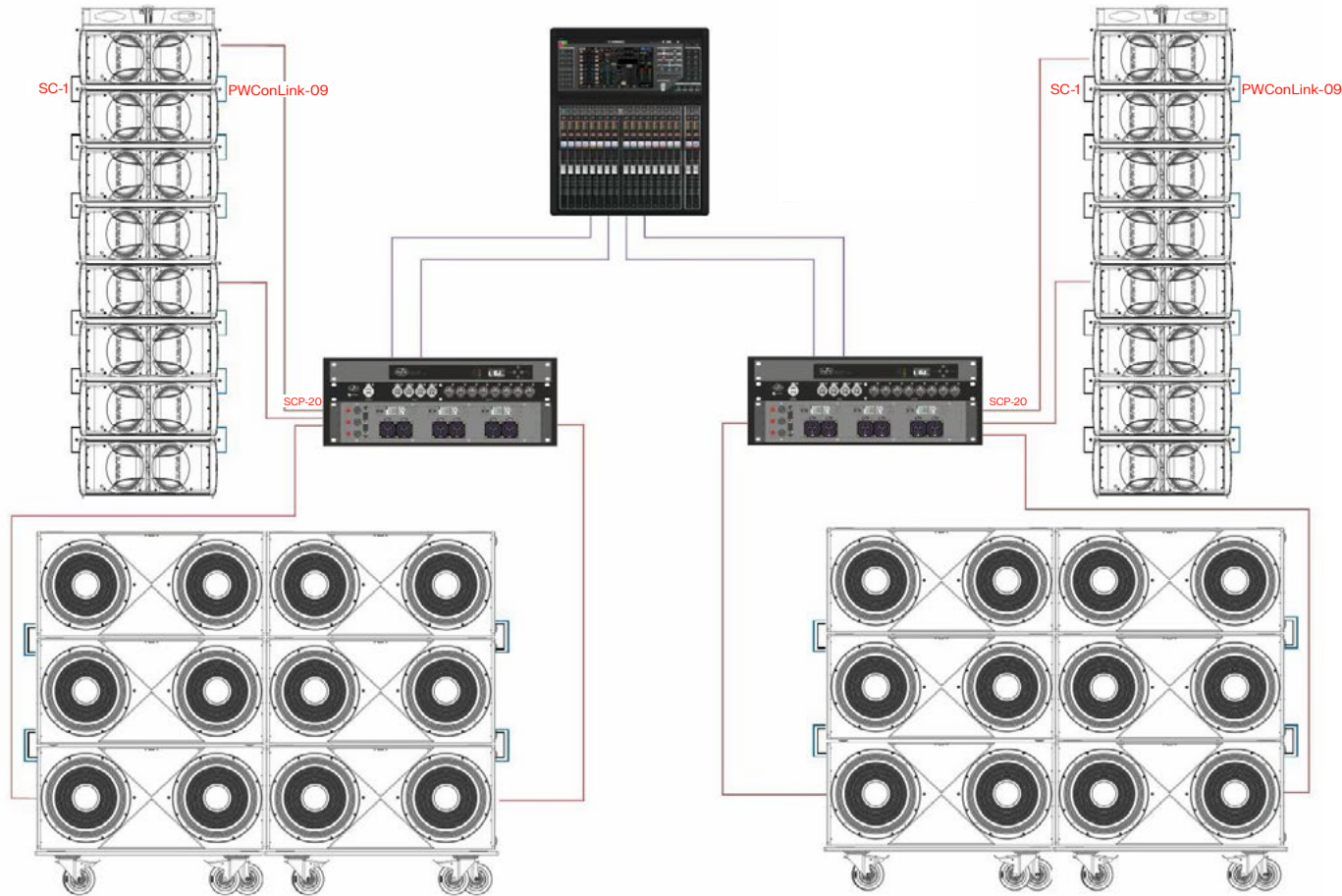

- List of material**
- 20 x PWCONLINK-09
 - 20 x CS-1
 - 8 x SCP-20
 - 2 x AX-EV30
 - 4 x PL-EV30S
 - 4 x FUN-4-EV30
 - 4 x PL-EVS218
 - 4 x FUN-3-EVS218
 - 2 x RACK-EVENT-230V

System Configurations

24 x EVENT-30A + 16 x EVENT-S218A

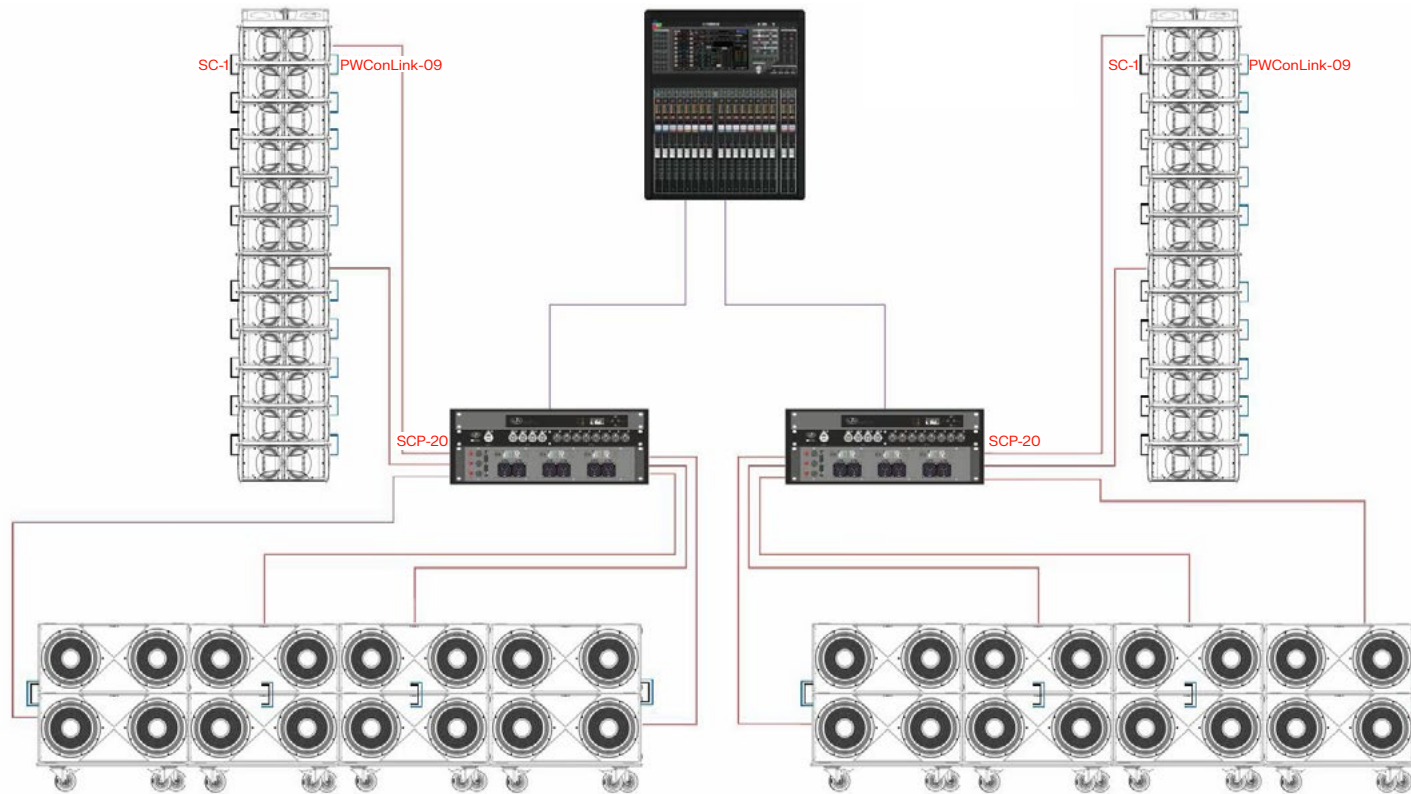

- List of material**
- 28 x PWCONLINK-09
 - 28 x SC-1
 - 12 x SCP-20
 - 2 x AX-EV30
 - 4 x PL-EV30S
 - 4 x FUN-4-EV30
 - 8 x PL-EVS218
 - 8 x FUN-3-EVS218
 - 2 x RACK-EVENT-230V

Technical Specifications

	EVENT-30A	EVENT-S218A
Amplifier Power LF (peak / continuous)	1700 W / 850 W	4500 W / 2250 W
Amplifier Power HF (peak / continuous)	300 W / 150 W	--
Amplifier Class	Class D	Class D (4-ch. Bridged 2+2)
Input Impedance	20 k Ω	20 k Ω
Input Sensitivity	6.2 V (+18 dBu)	6.2 V (+18 dBu)
Frequency Range (-10 dB)	63 Hz – 20 kHz	30 Hz – 100 Hz
Horizontal Coverage (-6 dB)	90°	--
Maximum Linear SPL ¹ at 1 m	138 dB	138 dB
Maximum SPL ² at 1 m	142 dB	142 dB
Transducers / Spare parts	LF: 2x 10WN4 (2.5") HF: 2x M-60 (1.75")	2x 18ESN (4")
Enclosure material	Reinforced polypropylene	Multi-layer birch plywood
Finish	Black paint	Black / ISOFlex polyurea
Rigging splay range	0°–10° in 1° steps (FSS™, up to 24 units)	--
Audio Signal Input Connector	1x XLR female	1x XLR female
Audio Signal Loop Thru Connector	1x XLR male	1x XLR male
AC Input / Output	powerCON NAC3FCA / NAC3FCB	powerCON NAC3FCA / NAC3FCB
Current Draw 230 V / 115V	1.5 A / 3.0 A	3.0 A / 6.0 A
Dimensions (HxWxD)	307 x 710 x 560 mm 12,1 x 28,0 x 22,0 in	555 x 1180 x 755 mm 21,9 x 46,5 x 29,8 in
Weight	26.5 kg (58.3 lbs)	78.0 kg (172.0 lbs)
Accessories	AX-EV30, AXS-EV30, PL-EV30S, FUN-4-EV30, FUN-6-EV30, TRD-8, SC-1, PWCONLINK-09	PL-EVS218, FUN-2-EVS218, FUN-3-EVS218, TRD-8, SC-1, PWCONLINK-09

Line Drawings

EVENT-30A

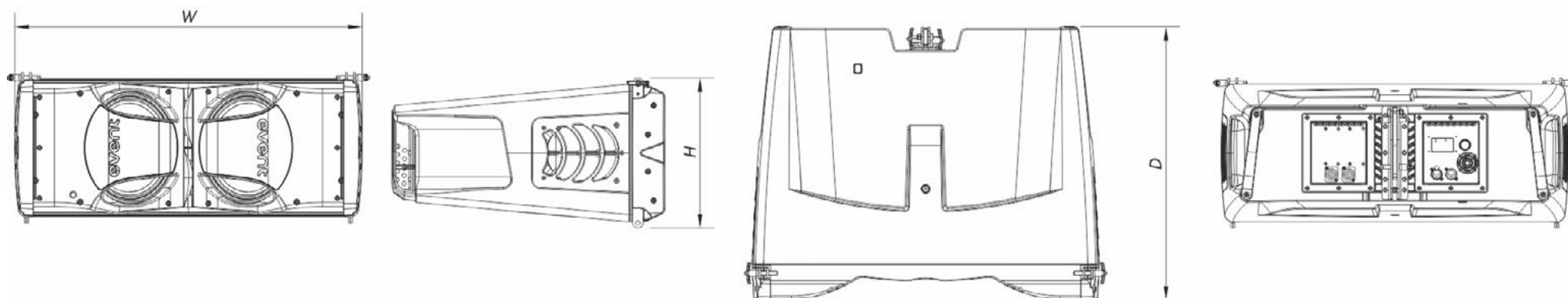

Line Drawings

EVENT-S218A

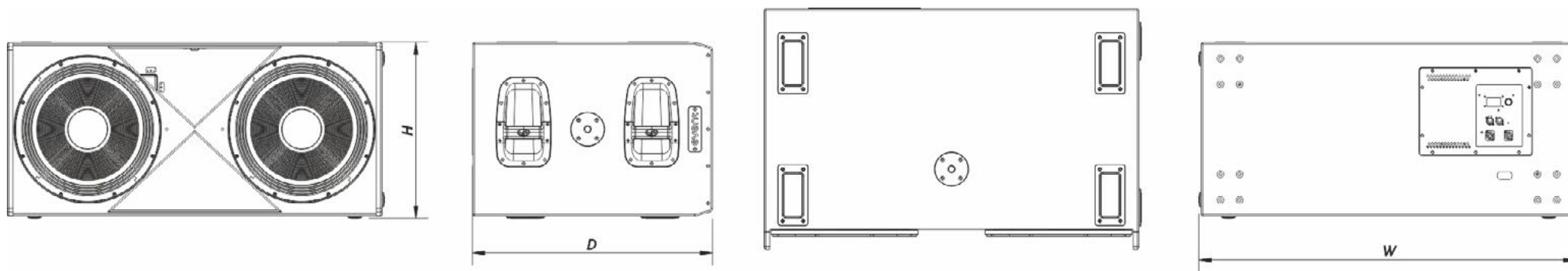

Amplifiers

EVENT-30A Amplifier

1. Input

Balanced XLR input signal connector. Like the OUTPUT connector, it is a balanced connector with the following pin assignment:

- 1 or S = GND (ground)
- 2 or T = (+) non-inverted signal
- 3 or R = (-) inverted signal

2. Output

XLR output signal connector for connecting several units and feeding all of them the same input signal (THRU).

3. Display

LIMIT / INPUT CLIP: The input signal level can be monitored on the left indicator of the LCD display. When the signal level is too high, "INPUT CLIP" will appear. Reduce the level accordingly in order to avoid distortion.

The output level relative to the limiter threshold is shown on the right indicator. When the limit is exceeded, "LIMIT" appears.

SIGNAL: The left indicator shows signal presence.

POWER ON: The display lights up when the system is switched on.

4. ENCODER (DAScontrol)

Use the rotary control (Encoder) to navigate through preset selection (number of units, throw, self tuning) and options (reset, dimming, etc.).

5. AC INPUT

PowerCon NAC3FCA connector (locking mechanism). Use only with the appropriate power cable.

6. AC OUTPUT

PowerCon NAC3FCB connector (see unit label). Use only with the appropriate power cable.

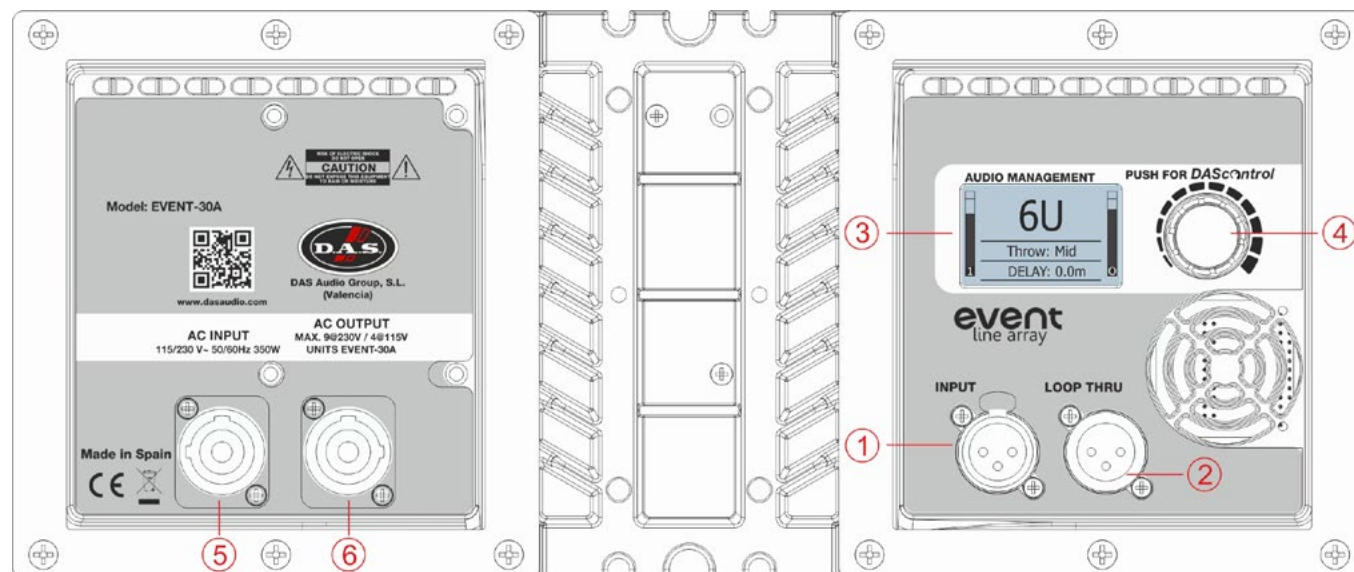

Amplifiers

EVENT-30A - DAScontrol and Display Navigation

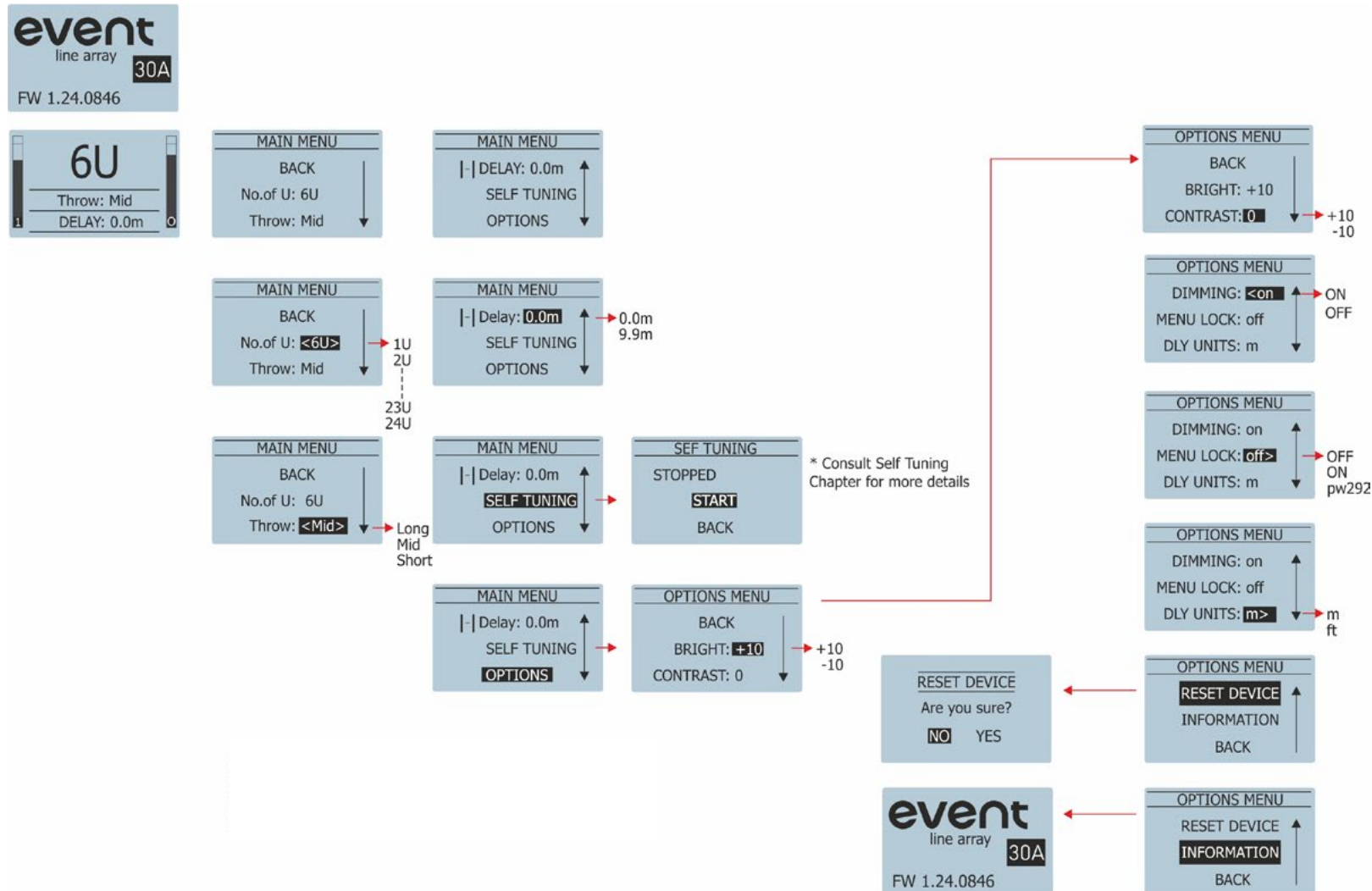

DIMMING
 OFF: the background light is always on.
 ON: the background light is lowered when the system doesn't Limit. When Limit is reached the background light increases its luminosity.

Amplifiers

Event-S218A Amplifier

1. Input

Balanced XLR input signal connector. Like the OUTPUT connector, it is a balanced connector with the following pin assignment:

- 1 or S = GND (ground)
- 2 or T = (+) non-inverted signal
- 3 or R = (-) inverted signal

2. Output

XLR output signal connector for connecting several units and feeding all of them the same input signal (THRU).



3. Display

LIMIT / INPUT CLIP: The input signal level can be monitored on the left indicator of the LCD display. When the signal level is too high, "INPUT CLIP" will appear. Reduce the level accordingly in order to avoid distortion.

The output level relative to the limiter threshold is shown on the right indicator. When the limit is exceeded, "LIMIT" appears.

SIGNAL: The left indicator shows signal presence.

POWER ON: The display lights up when the system is switched on.

4. ENCODER (DAScontrol)

Use the rotary control (Encoder) to navigate through preset selection (Low pass filters, deep & loud, cardioid preset) and options (reset, dimming, etc.).

5. AC INPUT

PowerCon NAC3FCA connector (locking mechanism). Use only with the appropriate power cable.

6. AC OUTPUT

PowerCon NAC3FCB connector (see unit label). Use only with the appropriate power cable.

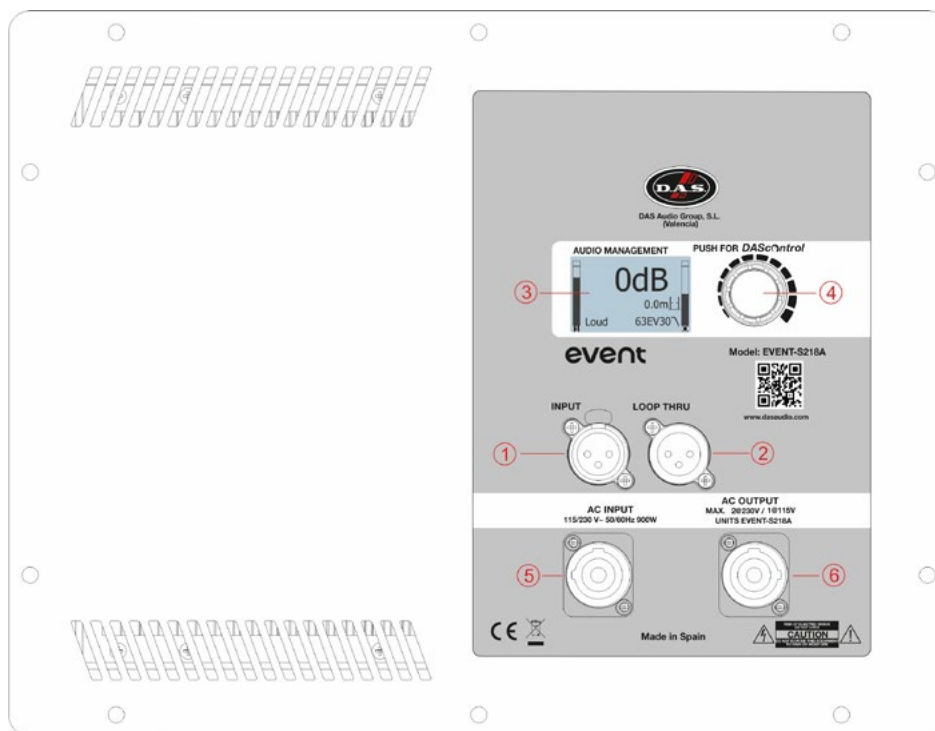

Amplifiers

EVENT-S218A - DAScontrol and Display Navigation

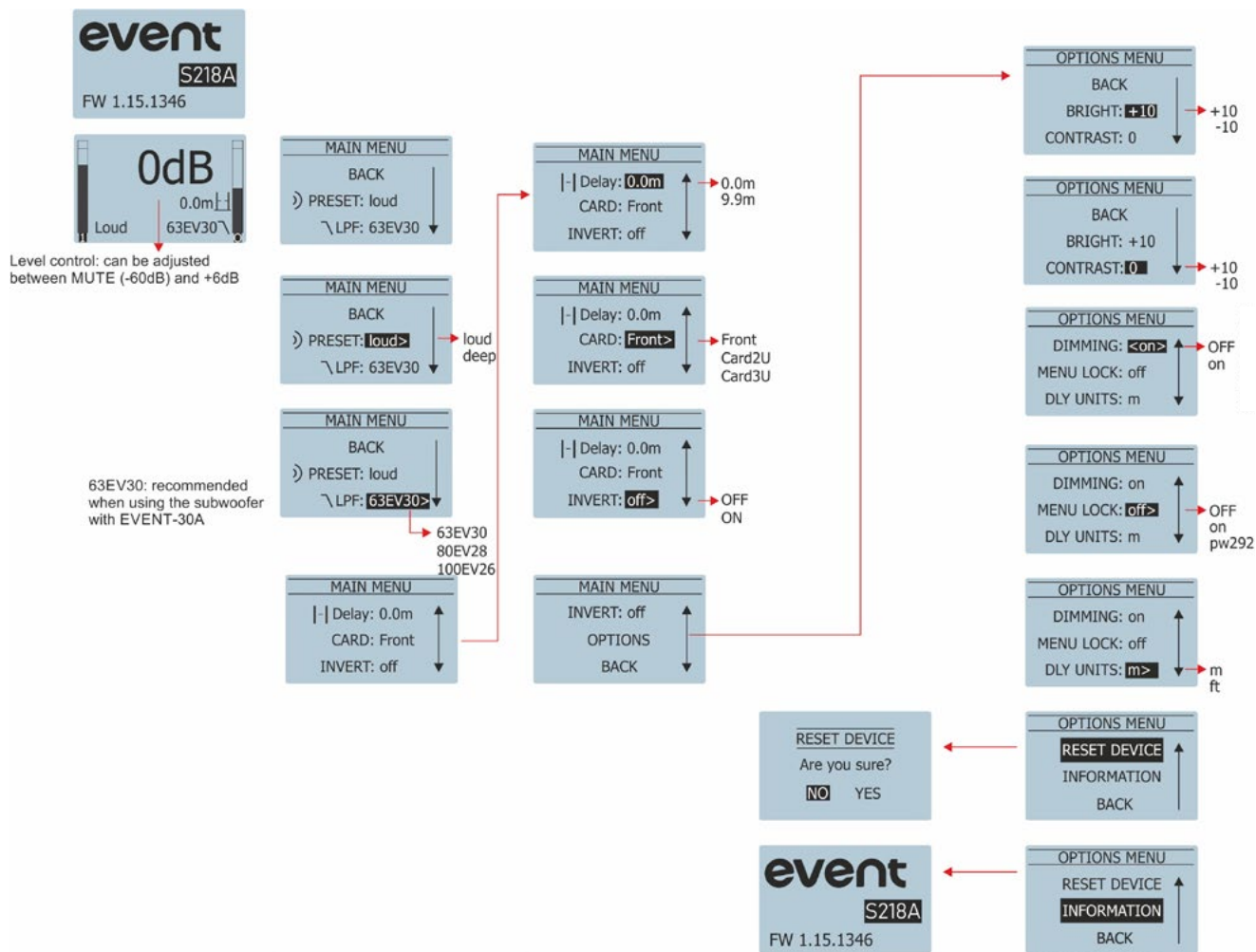

DIMMING
 OFF: the background light is always on.
 ON: the background light is lowered when the system doesn't Limit. When Limit is reached the background light increases its luminosity.

Amplifiers

Operating Recommendations

ON / OFF

When starting up a sound system, follow a set sequence.

Connect all signal cables before switching on the units.

Switch on self-powered systems last (subwoofers before mid/high-frequency systems). Switch on sound sources, then the mixing desk, processors, and finally the self-powered unit. If you have several units, switch them on sequentially, one by one or by groups.

When switching off, follow the reverse process and switch off the speakers before any other element in the system.

Disconnect the device by unplugging from the mains. The connector and socket must always be accessible and must never be covered or obstructed.

The models use a power cable with a Neutrik PowerCon NC3FCA connector. Several units can be daisy-chained using an NC3FCB connector (see product label).

IMPORTANT: Do not disconnect the equipment while it is in use. Verify that the equipment is disconnected from the mains by checking that the display is off.

Overload Indicator (LIMIT / INPUT CLIP)

The system incorporates two independent overload indicators on the display: INPUT CLIP and LIMIT, each corresponding to a different point within the signal chain.

INPUT CLIP indicates that the input stage is being overdriven due to excessive signal level. This condition is directly related to the input level meter (VU meter) and reflects insufficient headroom at the system input.

The INPUT CLIP indicator must never illuminate under normal operation. Input clipping results in severe signal distortion and may cause damage to the loudspeaker components. If this indication appears, immediately reduce the input signal level and review the system gain structure.

LIMIT indicates that one or more of the internal DSP limiters have been engaged. These limiters manage the dynamic range of the system and provide protection for both the low-frequency and high-frequency transducers.

The system is designed to operate safely with the LIMIT indicator appearing sporadically under high output conditions. However, continuous or excessive activation of the limiters is not recommended, as it may lead to reduced performance and increased thermal stress.

Number of Units

In all EVENT Series line array models, the **Number of Units** parameter compensates for the acoustic summation of low-mid frequencies that occurs when multiple enclosures are coupled in a vertical array. This effect is a natural consequence of the interaction between transducers operating in close proximity along the vertical plane.

To ensure a balanced frequency response, set the **Number of Units** parameter on each cabinet to match the total number of elements in the array.

For example, in a six-cabinet array, all units must be set to **Number of Units = 6**.

This adjustment allows the system's DSP to apply the appropriate correction, minimizing low-mid buildup and maintaining tonal consistency across the array.

The configuration process can be further optimized using the Self Tuning tool available in the EVENT-30A models.

For proper stereo balance and system coherence, both sides of the PA must be configured with the same **Number of Units** setting.

Amplifiers

Operating Recommendations

LPF

The subwoofer incorporates selectable low-pass filter (LPF) settings, which can be adjusted using the DAScontrol encoder.

These presets define the upper frequency limit of the subwoofer and are optimized to match different EVENT Series full-range systems:

- » 63EV30 – 63Hz low-pass filter, optimized for use with EVENT-30A systems
- » 80EV28 – 80Hz low-pass filter, optimized for use with EVENT-28A systems
- » 100EV26 – 100Hz low-pass filter, optimized for use with EVENT-26A systems

Each setting ensures proper crossover alignment between the subwoofer and the corresponding top cabinets, providing a smooth transition and consistent system response.

Select the LPF preset that matches the full-range system in use to achieve optimal performance.

Self Tuning

Smart Self-Tuning is an intelligent alignment technology that automatically optimizes system performance within a line array via bidirectional infrared communication. Consult the dedicated chapter for more information.

Cardioid Presets

The subwoofer includes dedicated **cardioid presets**, accessible through the display menu, designed to reduce sound radiation behind the system.

These presets allow the creation of cardioid subwoofer configurations by combining multiple units with specific orientation and DSP processing.

For a standard **2-unit cardioid configuration (2U)**:

- » One subwoofer must be oriented facing forward.
- » A second subwoofer must be oriented facing rearward.
- » The rear-facing unit must have the **Cardioid 2U** preset activated.

For larger setups, a **3-unit cardioid configuration (3U)** preset is also available, providing enhanced rear attenuation and improved directivity control.

In both configurations, the system applies optimized delay, polarity, and filtering to achieve cardioid behavior.

When properly configured, these presets provide a rear sound pressure level reduction of **more than 12 dB** compared to the forward radiation.

For correct operation, ensure proper physical placement and orientation of the subwoofers, and apply the appropriate preset only to the designated (rear-facing) unit(s).

Amplifiers

Operating Recommendations

Deep / Loud Preset

The subwoofer includes two selectable operating modes: Deep and Loud, allowing the system to be optimized according to application requirements.

Deep mode applies low-frequency equalization to enhance the perceived low-end depth of the system. This setting increases the subjective sense of bass presence and warmth, but does not extend the subwoofer's actual frequency range.

Loud mode prioritizes maximum output and efficiency, avoiding additional low-frequency boost in order to preserve headroom and achieve higher SPL capability. This setting is recommended for high-demand applications where maximum output and system impact are required.

Select the appropriate preset depending on the desired balance between perceived low-frequency enhancement and overall system output.

Equalization and System Alignment

The use of dual-channel FFT-based measurement software is strongly recommended to evaluate the system's frequency and phase response. This enables precise optimization based on objective data, including magnitude response, phase trace, and coherence.

This system does not require excessive equalization. By correctly setting the Number of Units parameter (or by using the Self Tuning tool), the system establishes a highly optimized baseline. This adjustment compensates for array coupling and low-mid summation effects, providing a well-balanced response with minimal need for corrective EQ.

Once this baseline is established, system optimization should follow a structured workflow:

1. Measurement: Acquire reliable transfer function data (magnitude, phase, and coherence) using a dual-channel FFT system. Ensure proper reference signal and adequate signal-to-noise ratio.

2. Time Alignment: Align subwoofers and full-range systems in the time domain to achieve optimal phase summation across the crossover region. Verify alignment through phase trace overlap and constructive summation.

3. Level Adjustment: Set the relative gain between subwoofers and tops according to the desired system voicing and application requirements.

4. Equalization: Apply minimal and targeted equalization only where necessary. Focus on broad-band corrections and avoid excessive filtering. Use EQ primarily to compensate for environmental effects such as room acoustics, boundary interactions, or system placement.

Maintaining this workflow—measurement → alignment → level → equalization—ensures optimal system performance, maximum headroom, and consistent tonal balance.

Avoid excessive equalization, as it can negatively affect phase response, reduce headroom, and compromise overall system coherence.

Self Tuning

Advanced Automatic Array Configuration in EVENT-30A

Overview

Smart Self-Tuning is an intelligent alignment technology that automatically optimizes system performance within a line array. Via bidirectional infrared communication (two sensors per unit), each system identifies its position in the array and communicates with the rest of the enclosures. The system determines the total number of cabinets, detects the top and bottom units, and recognizes the exact position and angle of each enclosure and the shape of the array. Then, it automatically selects the appropriate preset based on the array size, including long throw and short throw modes. This process ensures correct system behavior without manual configuration, significantly reducing setup time and potential errors. These parameters are identified:

- » Total number of units in the array
- » Exact position of each system within the array
- » Absolute Vertical angle (splay dependent) of each unit

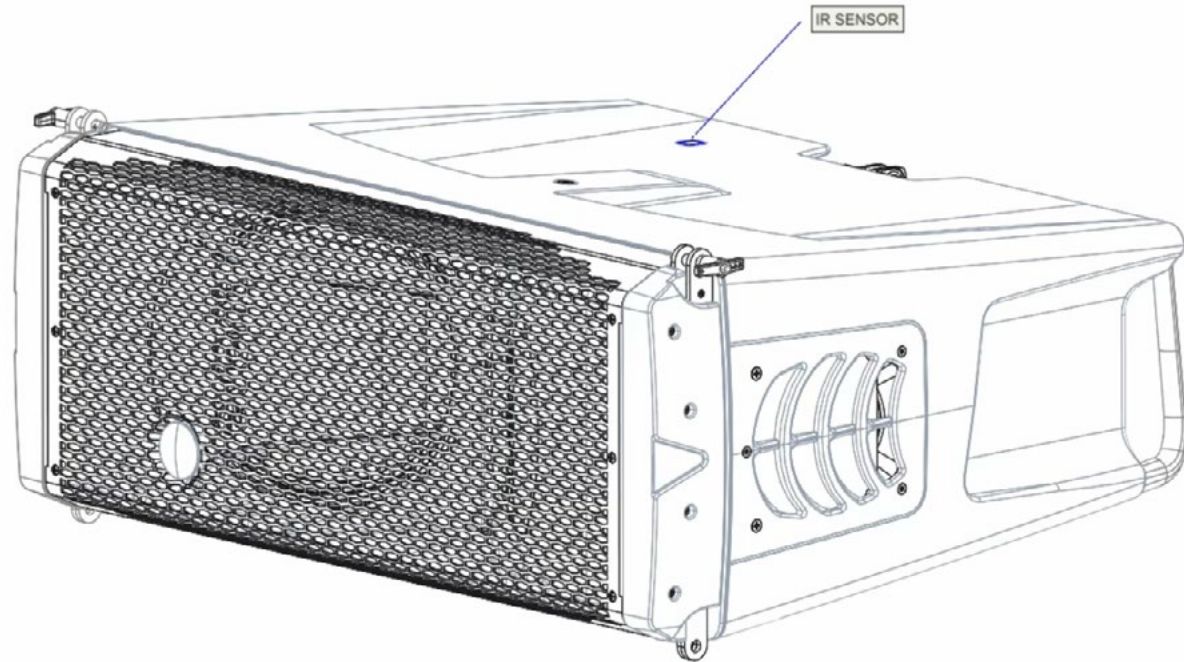

Self Tuning

Advanced Automatic Array Configuration in EVENT-30A

Scope of the Self-Tuning Process

1. Total Array Size Detection

All units are automatically set to the same value.

Number of Units = N

Example: For an array of 8 units: Number of Units = 8

Previously, this had to be manually set on each enclosure in models such as EVENT-26A and EVENT-28A, but now it is automatically synchronized across the system.

2. Position and Splay Angle Identification Through IR communication, each unit determines

» Its exact physical position within the array (system number 1, 2, ...,6 etc).

» The mechanical absolute vertical angle.

Note: The IR system operates reliably across the entire permitted splay range of angles (0°–10°), ensuring accurate detection regardless of angle configuration.

3. Automatic Coverage Assignment

» Long Throw → Upper cabinets, implementing atmospheric High Frequency correction to compensate air absorption at longer distances (D>45-50m).

» Mid Throw → Central cabinets.

» Short Throw → Lower cabinets.

Example for an 8-unit array:

» Top 2 → Long Throw.

» Middle 4 → Mid Throw.

» Bottom 2 → Short Throw.

Parameters Not Affected by the process

» Individual cabinet gain is not user-adjustable within the line array configuration.

» Self-Tuning does not modify presets unrelated to array processing.

» Delay or other system parameters are not altered.

Activation Procedure Steps

1. Power on all units.

2. Verify final mechanical configuration, including splay angles (0°–10°).

3. The process must be initiated from one single unit (any of them) and will temporarily act as the Master unit. To start the process:

» Access the menu via Display & Encoder

» Scroll down to SELF TUNING menu: SELF TUNING → START

4. Confirm execution by pressing the encoder.

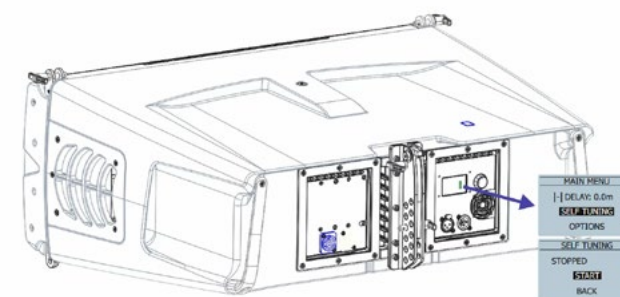

Self Tuning

Advanced Automatic Array Configuration in EVENT-30A

Once activated all the Displays in the array will change configuration and at the end of the process the Displays will show information like this:



All Units in the Array will have the very same “Number of Units” and the ST Icon will be displayed in all of them.

Internal Process Sequence When Self-Tuning starts

1. IR network is activated.
2. All active units are identified.
3. Physical order of units is determined.
4. Vertical Absolute Angles are detected.
5. Total array size is identified.
6. “Number of Units” and “throw” are synchronized across all cabinets
7. DSP adjustments are applied according to position and geometry.

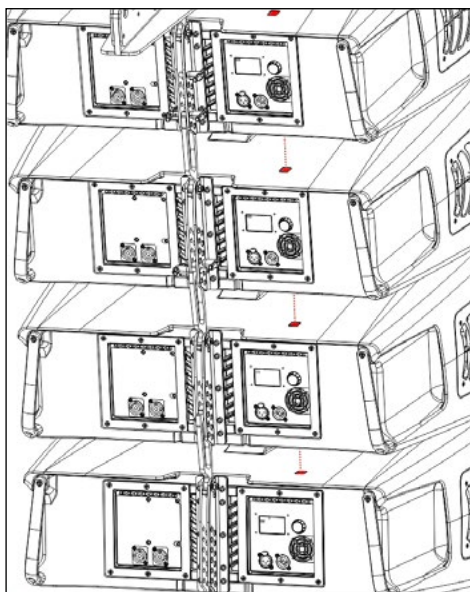

Visual Confirmation Once completed

- » Display confirms successful adjustment.
- » Self-Tuning active icon appears on all units (ST icon shown on Display).
- » Confirms full system synchronization.



If unsuccessful:

- » Icon does not appear and “Numer of Units” will not match the number of elements in the array.
- » Check power, mechanical alignment, and angles, then repeat SELF TUNING → START

Self Tuning

Advanced Automatic Array Configuration in EVENT-30A

Operational Advantages

- » Eliminates manual Number of Units adjustment (saving time).
- » Reduces human error.
- » Automatically detects position and working angle for mechanical confirmation.
- » Reliable operation across 0°–10° splay range.
- » Reduces setup time.
- » Ensures a proper set-up and performance of the arrays in any case.

Recommendations

- » All units must be powered on, before starting the Self-Tuning Process.
- » Execute the process whenever the number of unit changes, the array geometry is modified, or in any new setup.
- » Do not start until the mechanical configuration is complete.
- » Do not power off any unit during execution.
- » The process can be launched from any unit in the array, but only one unit should initiate it.
- » Once enabled, all systems in the array will keep in memory the settings; after any power off/on cycle, the settings will be reloaded as they are stored in the units.
- » The Self-Tuning Process can be stopped (cancelled) from any of the units in the array. Once the process has been disabled, the units will need manual adjustment of Number of Units.

Firmware Update (Wifi/Webserver mode)

The EVENT-30A and S218A systems incorporate an internal WiFi module that enables firmware updates via a built-in webserver interface.

To activate **Webserver Mode**, follow this procedure:

1. Connect the system to mains power using the PowerCON connector.
2. During startup, the DAS logo will appear on the display.
3. At this moment, press the encoder.
4. The system will initialize the internal WiFi access point and enter Webserver Mode.

Once activated, the display will show the WiFi network (SSID) generated by the unit.

For example, on EVENT-30A systems, the SSID will appear as:

» **wEVENT_XXX** (e.g., wEVENT_052)

This is the network to which you must connect using a tablet, mobile device, or computer.

After connecting to the system's WiFi network, open a web browser and enter the following address:

» **192.168.4.1**

This will provide access to the system's web interface, where the firmware update process can be carried out.

Before starting the update, ensure that the firmware file is downloaded and stored locally on your device. The latest firmware version can be obtained from the manufacturer's website.

Note that the system's WiFi network does not provide internet access, as it is intended exclusively for direct communication with the device.

During the update procedure, ensure that the system remains powered and that the connection is not interrupted. Disconnecting the unit or losing connection during the update may result in system malfunction.

Firmware Update (Wifi/Webserver mode)

Before performing a firmware update, it is recommended to verify the current firmware version installed on the system. This information can be accessed through the display menu (Information):



Ensure that the firmware file to be installed corresponds to the correct model (e.g., EVENT-30A or S218A). Installing incorrect or incompatible firmware may result in improper system operation.

When updating multiple units within the same system, it is strongly recommended to maintain all devices on the same firmware version. This ensures consistent behavior, proper DSP processing, and full compatibility between elements.

After completing the update, verify that:

- » The system reboots correctly.
- » The new firmware version is properly displayed.
- » All parameters and presets operate as expected.

If required, restore system settings and recheck key parameters such as **Number of Units**, cardioid presets, and gain structure.

Keeping the system firmware up to date ensures access to the latest performance improvements, feature enhancements, and stability updates.

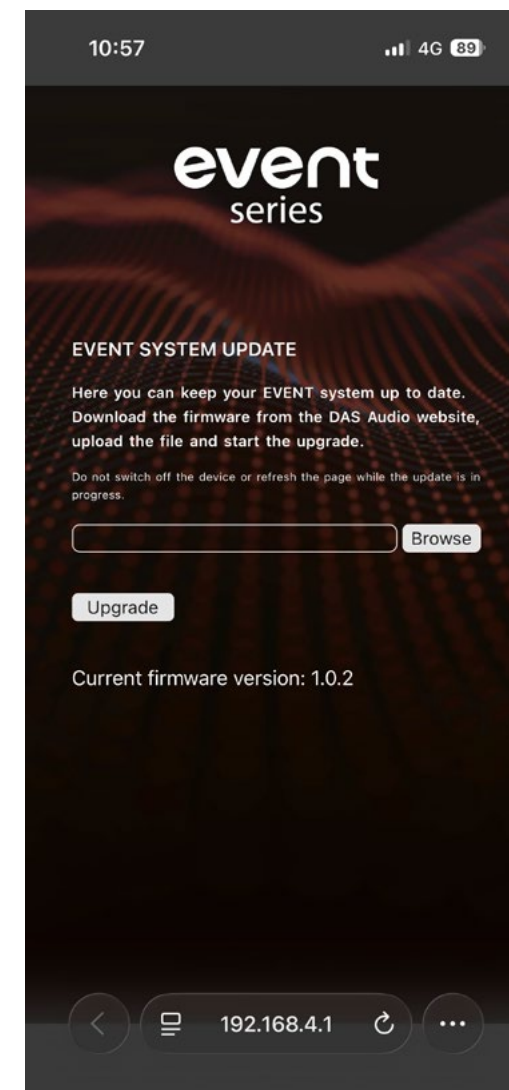

Troubleshooting

Problem	Cause	Solution
Unit does not produce sound. DISPLAY does not light up.	<ol style="list-style-type: none"> 1. No power reaching the unit. 2. Defective cable/connector. 3. Defective amplifier. 	<ol style="list-style-type: none"> 1. Check connections and power distribution. 2. Check cable and connector. 3. Contact your local distributor or service center.
Unit does not reach full level. LIMIT does not appear.	<ol style="list-style-type: none"> 1. Source has insufficient output level. 2. EQ, filters or compressors on other devices. 	<ol style="list-style-type: none"> 1. Use balanced output of a professional source. 2. Check signal path and remove EQ/compression.
Distorted sound. LIMIT not active; INPUT CLIP active.	Mixer or source distorting or input level too high.	Lower channel gain. Check no source is distorting.
Very loud distorted sound. LIMIT indicator lit.	System overloaded, maximum power reached.	Lower the mixer output level.
Noise or hum when mixer is connected.	<ol style="list-style-type: none"> 1. Unbalanced outputs / wrong cable. 2. Different mains outlet. 3. Cable too long or near power cable. 	<ol style="list-style-type: none"> 1. See appendix for unbalanced-to-balanced wiring. 2. Connect mixer and unit to same mains outlet. 3. Use shortest cable; keep signal cable away from power.
Noise or hum with lighting dimmers.	<ol style="list-style-type: none"> 1. Signal cable too close to lighting cables. 2. Sound system on same phase as lighting. 	<ol style="list-style-type: none"> 1. Separate signal cables from lighting cables. 2. Connect sound system to a different phase.
DISPLAY does not light up when unit is connected and ON.	<ol style="list-style-type: none"> 1. Bad cable/socket. 2. Defective AC wiring. 3. Blown fuse. 4. Mains voltage out of range. 	<ol style="list-style-type: none"> 1. Check connections. 2. Check cables with multimeter. 3. Replace fuse with same type. 4. Consult electrician.
Self Tuning process completed but ST icon does not appear on one or more units.	<ol style="list-style-type: none"> 1. IR sensor obstructed or blocked between units. 2. Mechanical splay angle out of permitted range (>10°). 3. Process was started before all units were powered on. 	<ol style="list-style-type: none"> 1. Check that no cable or object is blocking the IR sensors on the rear panel between adjacent units. 2. Verify all splay angles are within 0°–10°. 3. Power on all units, verify mechanical setup is complete, then re-run SELF TUNING → START on any of the units.
"Number of Units" does not match across all displays after Self Tuning.	<ol style="list-style-type: none"> 1. One or more units lost power during the process. 2. Process was cancelled before completion. 3. IR communication interrupted mid-sequence. 4. IR sensor obstructed or blocked between units. 	<ol style="list-style-type: none"> 1. Ensure all units remain powered throughout the entire process. 2. Do not cancel once started. Re-run SELF TUNING → START from any unit. 3. Check IR sensor alignment and repeat the process. 4. Check that no cable or object is blocking the IR sensors on the rear panel between adjacent units.
System sounds incorrect after reconfiguring the array (adding/removing units or changing splay).	Self-Tuning has not been re-executed after the array geometry changed. Units retain previous position and throw presets.	Whenever the number of units changes or the array geometry is modified, always re-run SELF TUNING → START before the event.
After power cycle, one unit reverts to manual settings and does not match the rest of the array.	Self-Tuning was not successfully completed on that unit during the last session. Settings are only stored after a successful process.	Re-run SELF TUNING → START with all units powered on. Verify the ST icon appears on every display before powering off.
Self-Tuning process does not start when initiated.	<ol style="list-style-type: none"> 1. Not all units in the array are powered on. 2. Array mechanical setup is not complete. 3. Another unit is already running the process. 	<ol style="list-style-type: none"> 1. Power on all units and wait for displays to initialize before starting. 2. Confirm all cabinets are mechanically connected and splay angles are set. 3. Only one unit should initiate the process. Check all displays and retry.

Rigging

Warning

This manual provides all the information necessary to fly or ground-stack systems from the EVENT Line Array series by DAS Audio. Before carrying out any operation related to flying the system, read this document and follow all safety warnings and recommendations.

Only highly experienced installers with adequate knowledge of the equipment and local safety regulations should be responsible for flying loudspeaker systems. It is the user's responsibility to ensure that the systems to be flown (including flying accessories) comply with all applicable state and local regulations.

The working load limits in this manual are the result of tests carried out by independent laboratories. It is the user's responsibility to follow and comply with the safety factors, resistance values, periodic inspections and warnings listed in this manual.

It is common practice to apply safety factors of 5:1 for cabinets and static elements. For slings:

- » 5:1 for steel wire rope
- » 4:1 for steel chain
- » 7:1 for polyester

When a system is suspended, the working load must be less than the resistance of each individual anchor point and each cabinet. Suspension accessories must be inspected periodically; replace suspect units if in doubt.

This is essential to avoid accidents. It is highly recommended to implement an inspection and maintenance program for flying elements, including inspection reports. There may be local regulations that, in the event of an accident, require presentation of inspection reports and corrective measures adopted.

Under no circumstances should risks be taken regarding public safety. When cabinets are suspended from ceiling-fixed structures, exercise extreme caution by calculating the load capacity beforehand. Never hang cabinets from structures without safety guarantees. Consult a qualified professional if required. Flying accessories are the sole responsibility of the user.

EVENT-30A:

The splay angle varies from 0° to 10° in 1° steps.

To **lock the splay** angle between units when flying or stacking, two pins are needed at the rear: one to be placed into the desired angle hole (into the upper unit) and the second one, in the "angle +1°" hole.

Rigging

Assembling 4 or 6 units on transport dolly PL-EV30S

Groups of four or six EVENT-30A units are easy and convenient to transport by truck, as shown in this manual.

After removing the packaging, the unit has four safety pins in the suspension system at the rear. The EVENT-30A uses a 3-point fixing system: two pins at the front (one each side) and two at the rear.

The PL-EV30S dolly includes 3 safety pins for stacking the first unit.

Caution: When attaching the first unit to the dolly, insert the rear pin of the dolly in the 1° hole of the first EVENT-30A unit.

To transport the units, in order to secure the package, set all splay angles at 10°. Use one rear pin to be inserted through the 10° hole and store the other pin in the “pin holder” hole as shown in the picture.

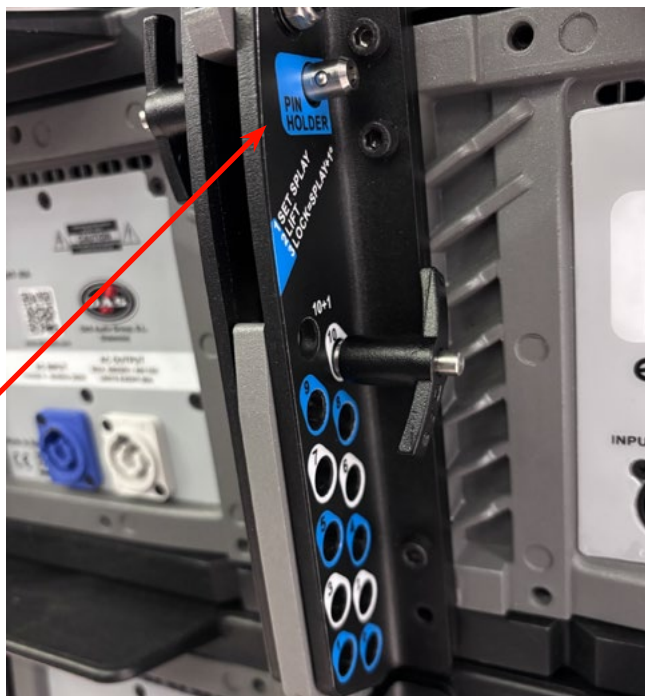

In the image below the PL-30S dolly with the first units are shown.

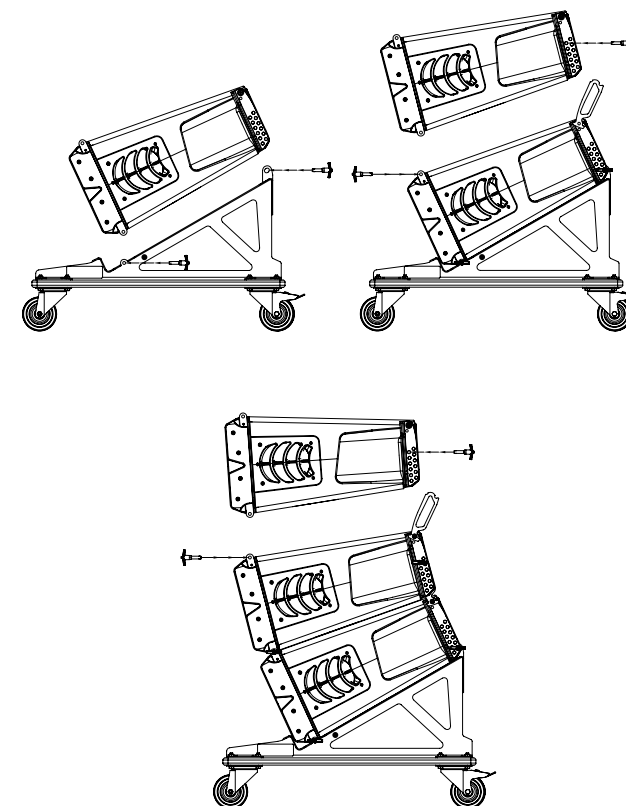

Rigging

Assembling 4 or 6 units on transport dolly PL-EV30S (continued)

Repeat the process shown in the previous section with the remaining units. The image below shows the assembly of 4 units. Remember that a group of six EVENT-30A can also be transported with one dolly.

Prior to rigging the system, the user should attach the AX-EV30 suspension accessory to the top cabinet: two pins at the front, one at the rear. Store the extra pin inside the cabinet's "pin holder" hole.

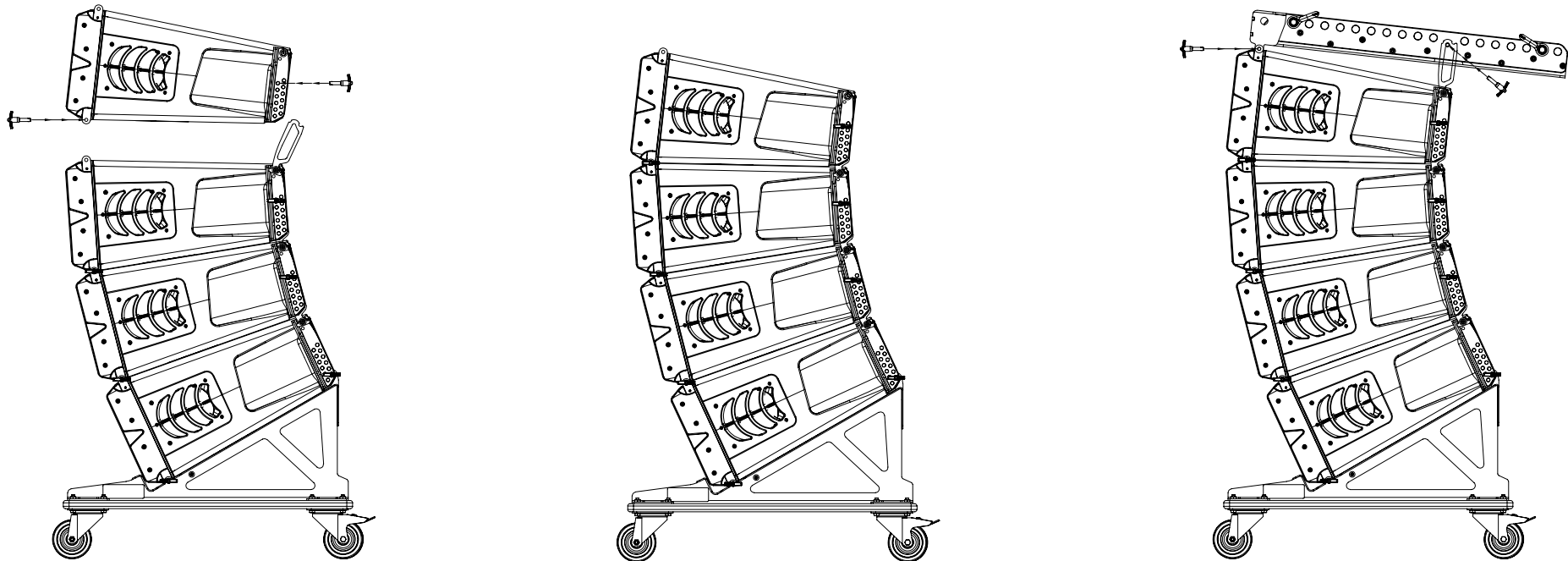

Rigging

Array Assembly — groups of 4 units on transport dolly

Run a simulation with Ease Focus 3 (visit www.dasaudio.com to download the software and the Event GLL files) to determine the splay angle between cabinets and the pin point position. Set the angle according to the simulation before attaching the lifting hoist.

The first selected group of 4 units will be at the top of the array. Before fitting the AX-EV30, remove the protective cover and the pins from the top cabinet.

Fit the AX-EV30 accessory: Insert the top cabinet pins into the corresponding holes of the AX-EV30 (3 pins required).

Place the shackle at the AX-EV30 pin point indicated by Ease Focus 3 and, before lifting, remove the pins connecting the bottom cabinet to the transport dolly.

Adjust splay angle between units according to Ease Focus 3 simulation. At this point use only one rear pin per cabinet. Introduce the pin in the desired splay angle hole.

Remove pins from dolly before lifting.

Caution: Check the correct installation of the safety pins. These pins will support the entire load.

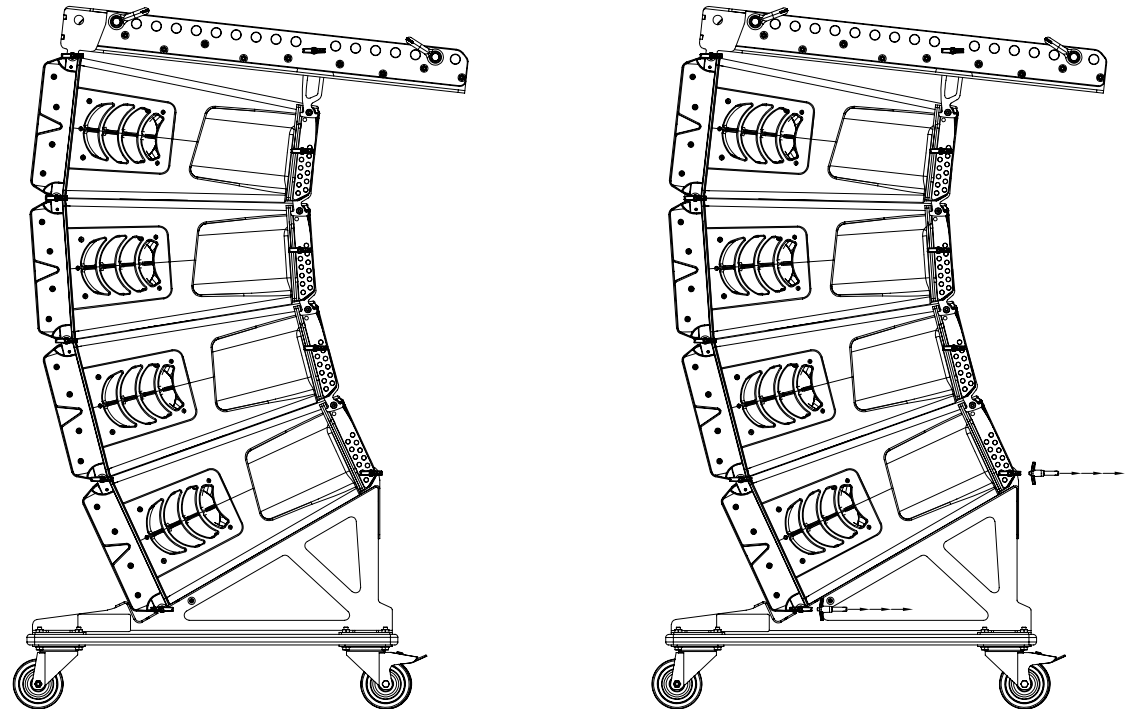

Rigging

Lift the system. The splay angle between cabinets will adjust automatically when using 3 pins (two at the front, one at the rear).

NOTE: If the user needs to lock the splay angle, insert the additional pin (pin 4) in the rear plate in the hole marked "angle+1°".

Repeat the process with the next dolly:

Lower the first four flown units till a convenient height to connect both groups of systems at the front.

Set the splay angle of the systems stacked on the dolly with one pin at the rear.

Continue lowering the first group till the rear cam link connection to the upper group is possible.

Join the two groups and raise all cabinets together.

Once all systems are up in the air, secure with the extra pin the 4 bottom cabinets (splay angle +1° position).

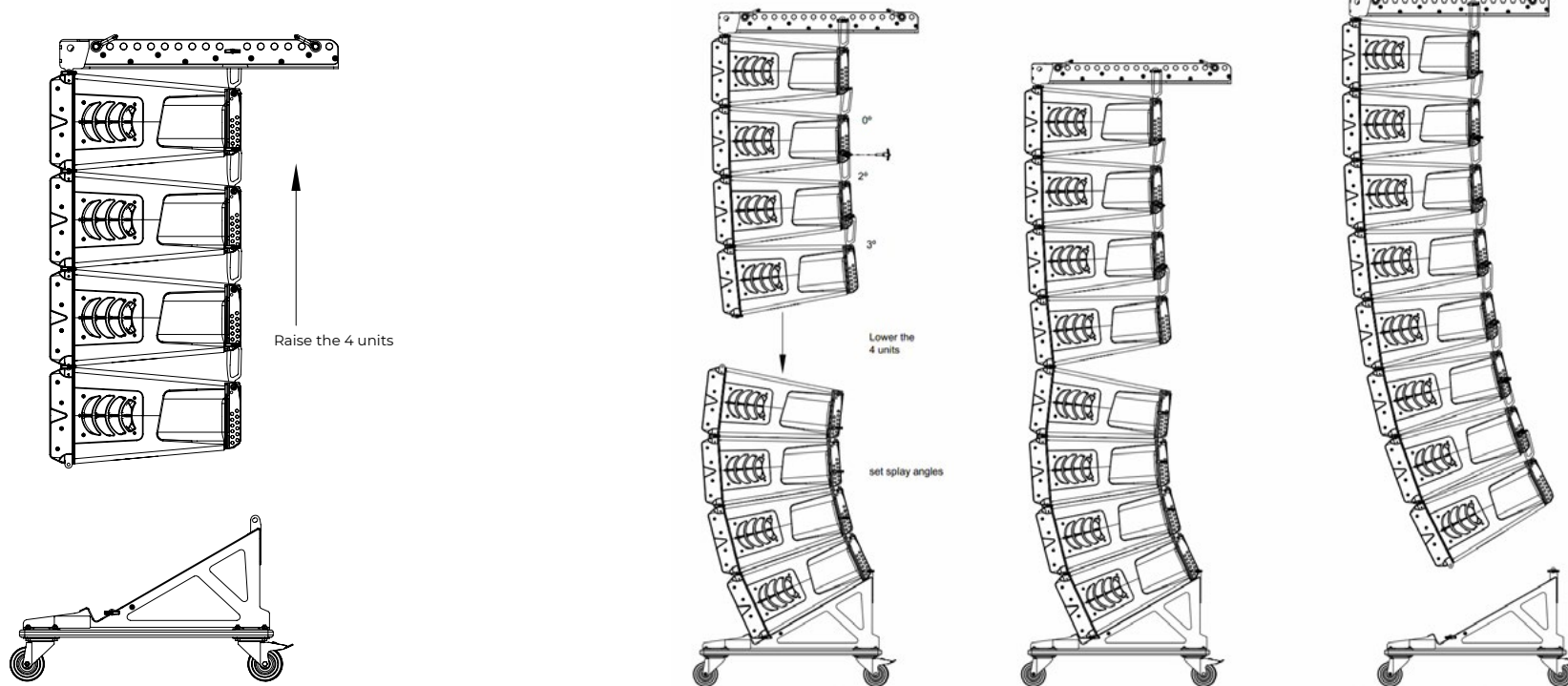

Rigging

EVENT-30A Array Assembly — cabinet to cabinet

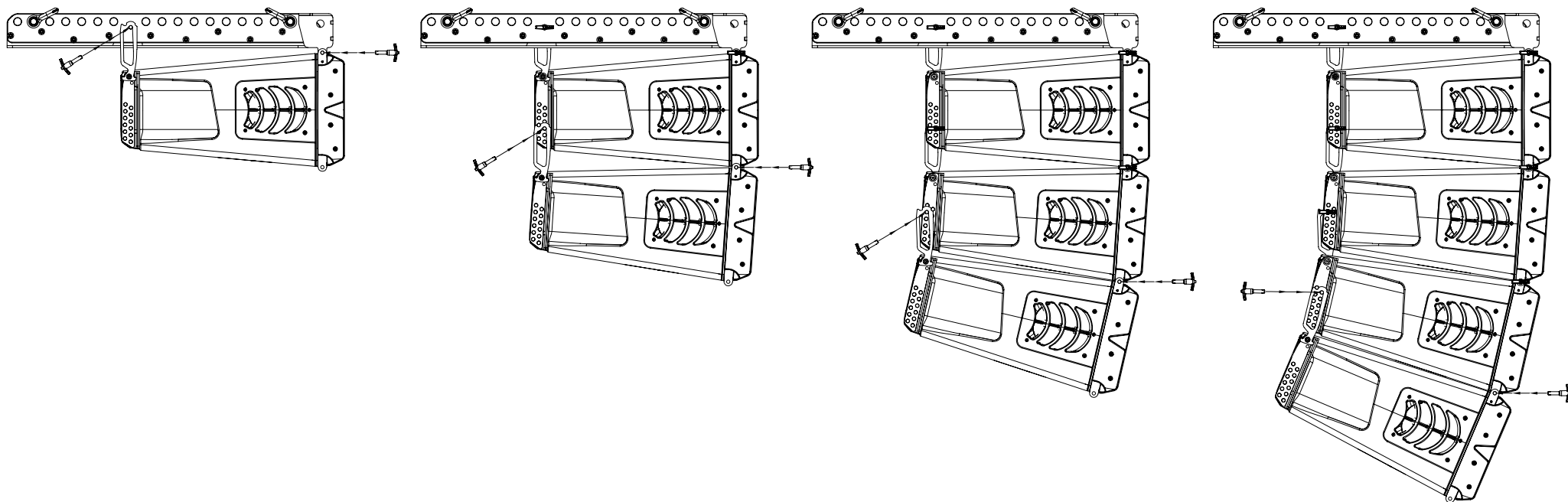

Rigging

EVENT-S218A Transport Dolly Assembly

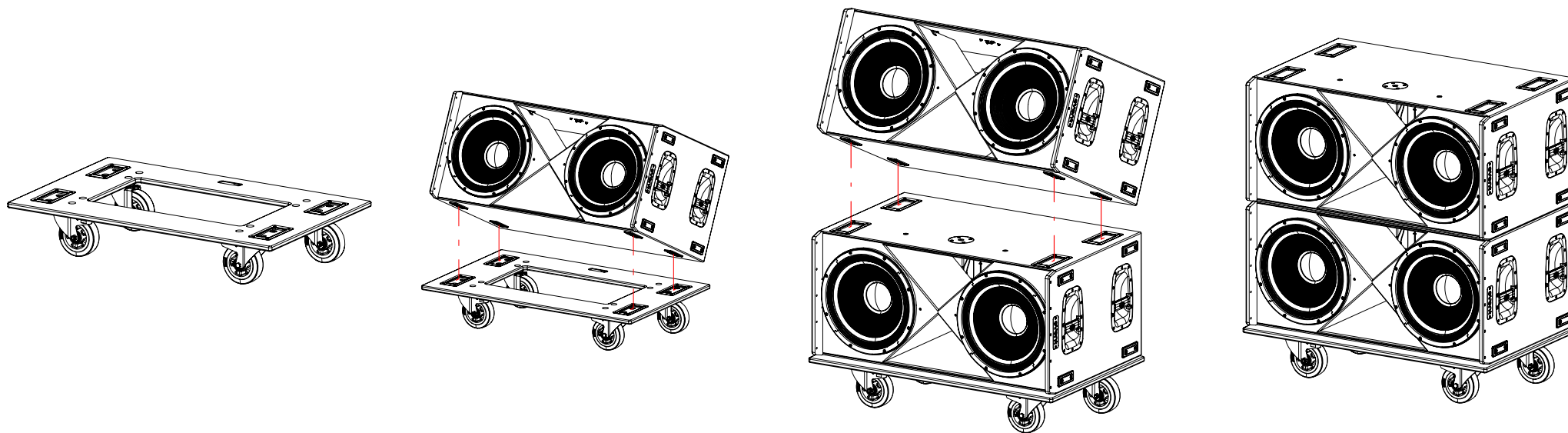

Rigging

Mounting EVENT-30A with AXS-EV30

When using the AXS-EV30 accessory to mount a system on a TRD-2 tripod or TRD-7 mast, the AXC-ZT accessory is required. The same applies when mounting together with an EVENT-S218A system.

Step 1 — Fix the AXS-EV30 accessory to the EVENT-30A.

Step 2 — Fix the AXC-ZT to the AXS-EV30.

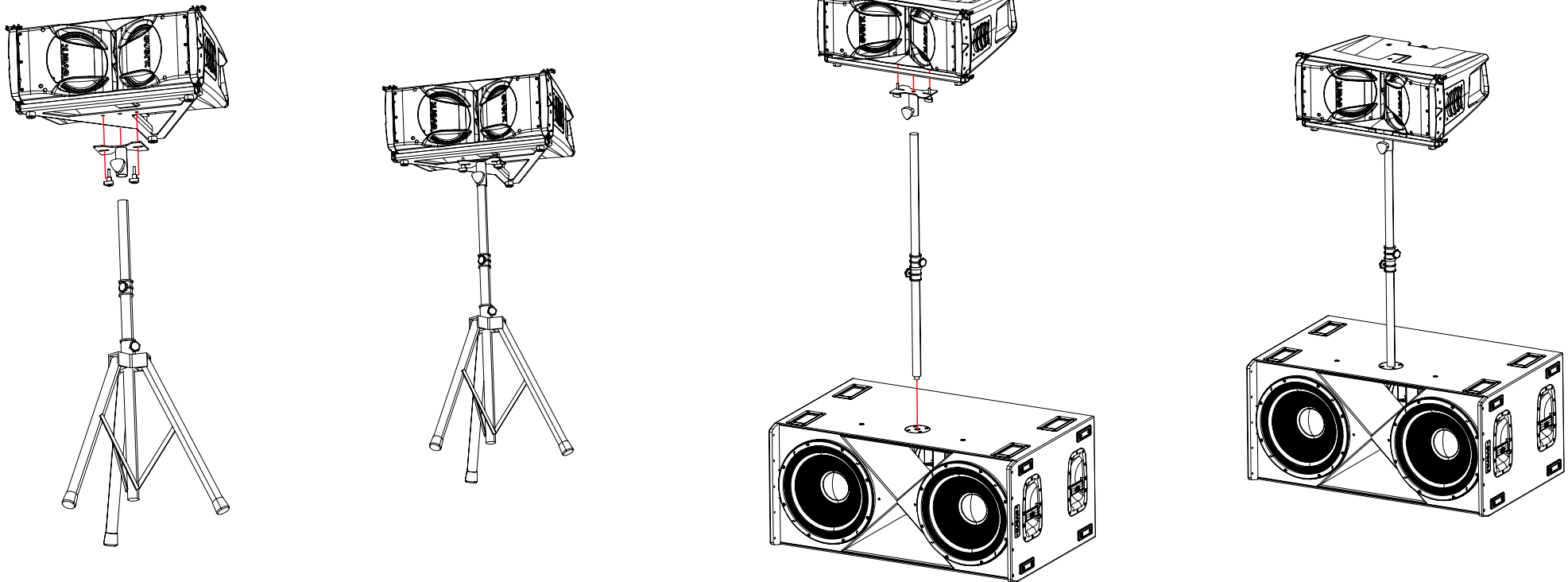

Rigging

Transport

Being a compact system, tops and subs can be transported together efficiently. The diagrams below show standard truck loading configurations.

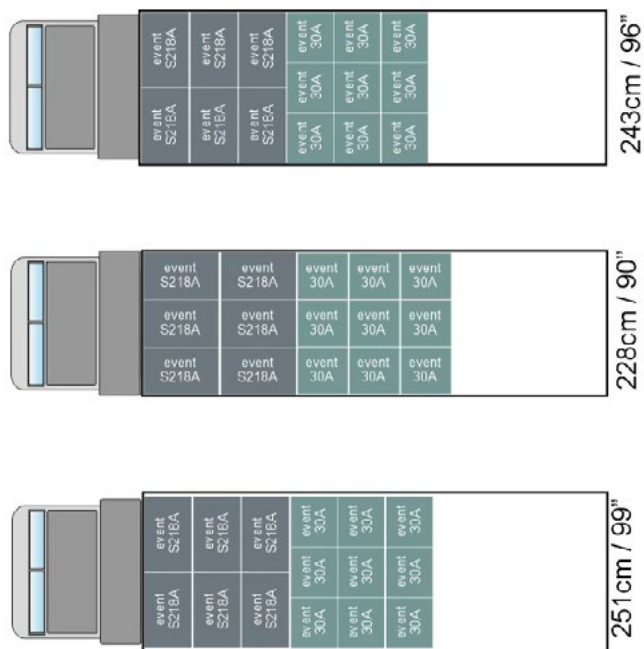

Fig. — Truck loading diagrams:
EVENT-30A and EVENT-S218A
(228 cm / 90"
243 cm / 96"
251 cm / 99")

Appendix

Line Connections - Unbalanced and Balanced

There are two basic methods for transporting audio signal at microphone or line level:

Unbalanced Line: Uses a cable with two conductors, carrying the signal as a potential difference between them. Electromagnetic noise from the environment can add to the signal. Connectors: RCA (Phono) and 1/4" mono 6.35 mm Jack. An XLR connector can also carry an unbalanced signal if one pin is unused.

Balanced Line: Uses a cable with three conductors. One serves as a shield (earth). The other two carry the same voltage relative to earth but with opposite signs. Noise affecting both cables equally is cancelled by the differential input circuit. Balanced connectors: XLR and 1/4" stereo Jack.

The following diagrams show the recommended connections. On the unbalanced connectors (left), two terminals are joined inside the connector. For balanced output to balanced input, if hum appears, try disconnecting the sleeve/ground on the input connector. Pin 2 is assumed as positive on XLR connectors.

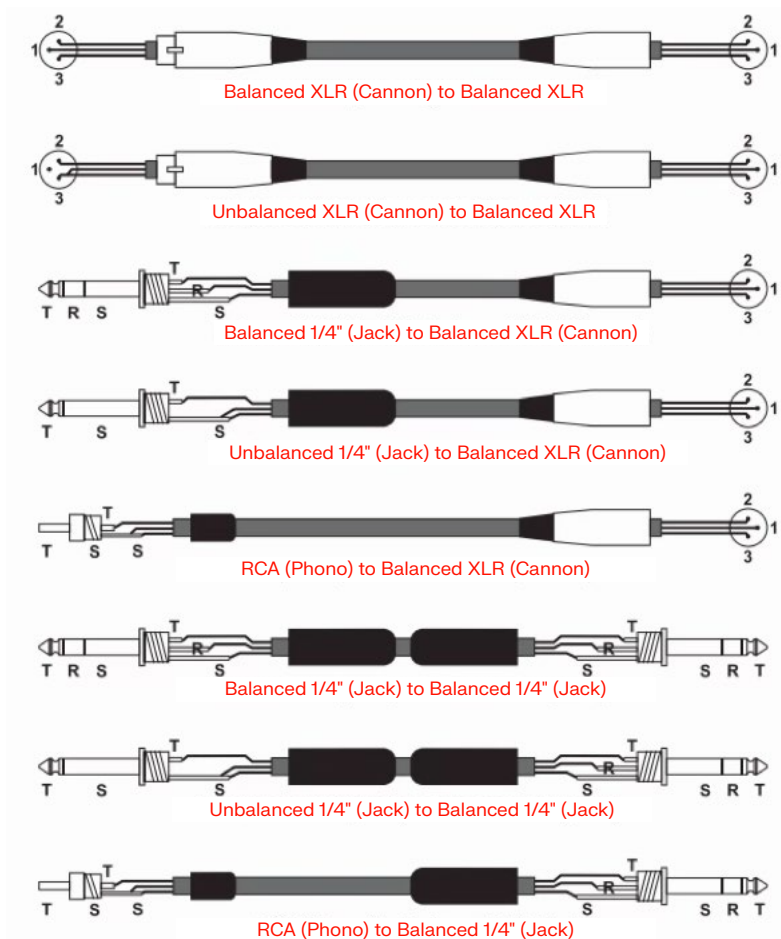

Fig. — Unbalanced XLR – XLR



DAS Audio Group, S.L.

C/ Islas Baleares, 24
46988. Fuente del Jarro
Valencia - Spanien
Tel. +34 961 340 860

DAS do Brasil Ltd.

Rua Dos Andradas, 382 SL
Santa Efigênia, São Paulo
Brasilien. CEP: 01208-000
Tel. +551133330764

DAS Audio of America, Inc.

6900 NW 52nd Street Miami, FL 33166
– U.S.A
Tel. +1 305-436-0521

DAS Audio China

Han Kou Road 309, Room 302
Huang Pu District
上海市黄浦区汉口路309号302室
200001 – Shanghai – China
Tel. +86 21 5169 0869

DAS Audio Asia PTE. LTD.

9 Gray Lane 03-01
Signature Crest
Singapore 438951
Tel. +65-9739-5000

DAS Audio GmbH

Mülheimer Str. 48
53840 Troisdorf
Germany
Tel. +49 2241 945880

