

EVENT-M12A

event
series

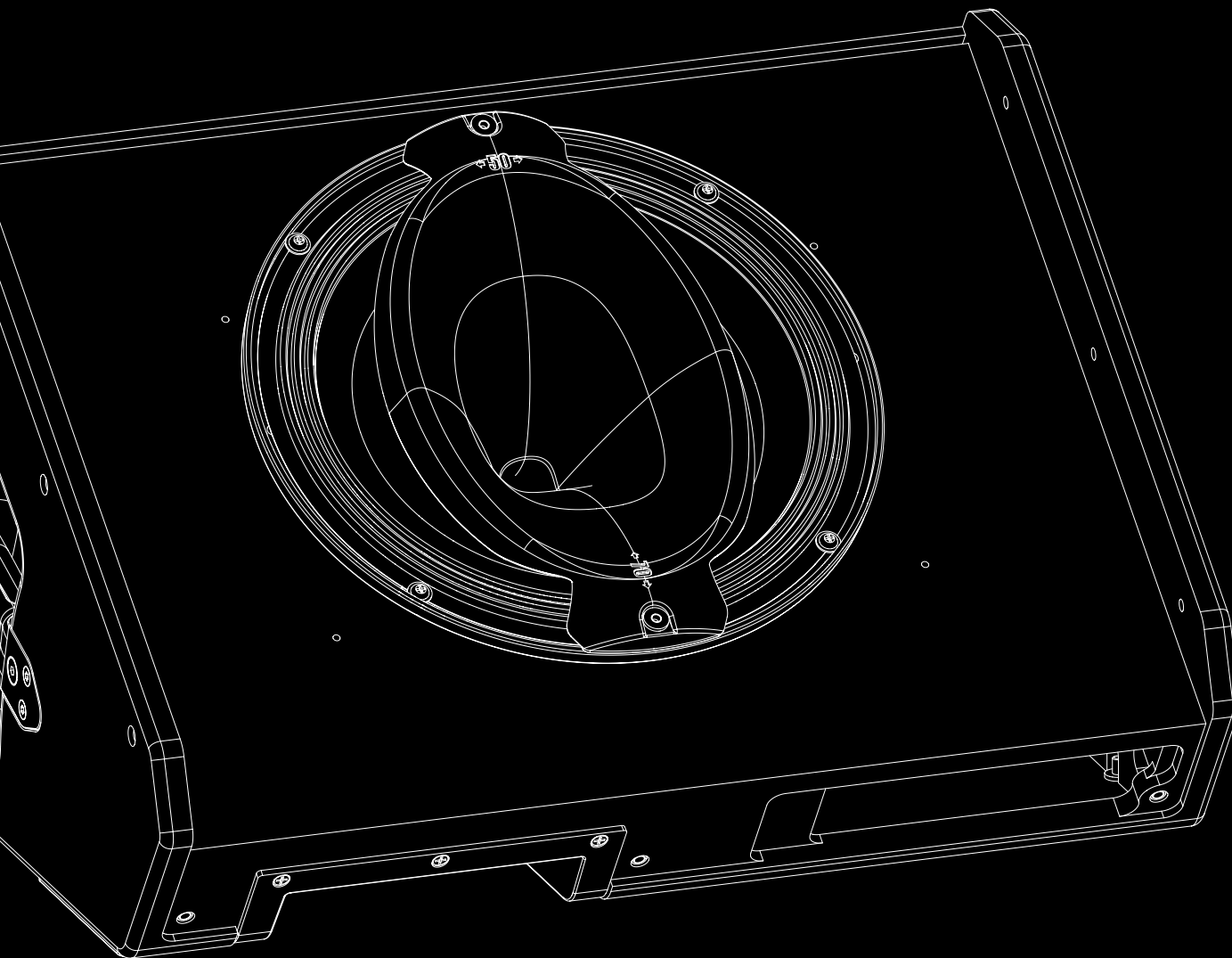

 **DAS AUDIO**

www.dasaudio.com



Before operating the device, please read the “Safety precautions” section of this manual.

Retain this manual for future reference.

Safety precautions	4
Declaration of conformity	5
Warranty	6
Introduction	7
Connectors and controls	8
Installation	9
Configuration	10
DSP & Wi-Fi	13
Specifications	14
Ordering Information	16

Safety precautions

Please read all safety instructions carefully before installing or operating the EVENT-M12A. Failure to observe these precautions may result in injury, equipment damage, or both.

Read all instructions before operating this equipment. Retain all instructions for future reference.

Do not use this equipment near water or in damp environments. Keep the equipment dry at all times.

Ensure adequate ventilation. Do not block ventilation openings or install in a confined space without proper airflow.

Connect only to a power source of the type described in the operating instructions or as marked on the product. The EVENT-M12A operates on universal mains voltage (115/230V - 50/60 Hz).

The powerCON AC connectors are locking connectors. Always ensure they are fully seated and locked before applying power.

Do not defeat the safety purpose of the AC connector. Route power cables to prevent tripping hazards or damage.

Protect the power cord from being walked on or pinched, particularly at plugs, receptacles, and the point where they exit the equipment.

Disconnect the unit from the mains supply before making or changing audio connections.

Do not attempt to service this equipment yourself. Refer all servicing to

qualified service personnel. Servicing is required when the apparatus has been damaged, liquid has entered the unit, or the unit does not operate normally.

The equipment is heavy (21 kg / 46.3 lb). Use proper lifting techniques and engage sufficient personnel when handling or positioning the unit.

When used as a stage monitor, ensure the unit is placed on a stable, level surface. Do not place in positions where it may tip or fall.

When pole-mounting, use only approved pole-mount stands rated for the weight of the system. Verify all mounting hardware is correctly secured before use.

This unit produces high sound pressure levels. Prolonged exposure to high SPL can cause permanent hearing damage. Use hearing protection where appropriate.

Do not expose the unit to extreme temperatures, direct sunlight, or environments with excessive humidity or condensation.

Disconnect the unit from all power sources during electrical storms or when left unused for extended periods.

This equipment must be earthed (grounded). Ensure the building installation provides a proper protective earth connection.

Declaration of conformity

DAS Audio Group, S.L.

C/ Islas Baleares, 24 - 46988

Pol. Fuente del Jarro - Valencia. Spain

Declares that models EVENT-26A and EVENT-115A:

Abide by essential objectives relating Directives:

- | | |
|---|------------|
| · Low Voltage Directive | 2014/35/UE |
| · EMC Directive | 2014/30/UE |
| · RoHS Directive | 2011/65/UE |
| · WEEE Directive | 012/19/UE |
| · Commission Delegated Directive 2015/863/EU and amendments | |

In accordance with Harmonized European Norms:

- EN 62368-1:2020 + A11:2020 Audio/video, information and communication technology equipment - Part 1: Safety requirements
- EN 55032:2015 + A11:2020 + A1:2020 Electromagnetic compatibility of multimedia equipment. Emission requirements.
- EN 55035:2017 + A11:2020 Electromagnetic compatibility of multimedia equipment. Immunity requirements.
- EN IEC 63000:2018 Technical documentation for the assessment of electrical and electronic products with respect to the restriction of hazardous substances.

Warranty

All our products are warranted for a period of 24 months from the date of purchase.

The warranty excludes damage resulting from incorrect use of the product.

All warranty repairs must be carried out exclusively by the manufacturer or the authorized technical service.

To request a warranty repair, do not open the product or attempt to repair it.

All warranty details (including warranty extension) can be found in the SUPPORT section of our website: www.dasaudio.com

Introduction

EVENT-M12A

The EVENT-M12A is an ultra-compact, self-powered two-way coaxial monitor designed to deliver precise coverage, high dynamic range, and discreet integration in demanding professional environments. Its design makes it a versatile solution for both stage monitoring applications and use as a point-source system.

The system is based on a coaxial design that combines a 12" low-frequency transducer with a 3" voice coil and a high-frequency compression driver with a 2.5" voice coil, mounted on a common acoustic axis. This configuration enables a compact enclosure, symmetrical coverage, and coherent behavior across the entire frequency range, ensuring consistent and accurate monitoring. Despite its compact size, the EVENT-M12A delivers a surprisingly extended low-frequency response, reaching down to 60 Hz. Dispersion is controlled by a numerically optimized 50° × 70° horn, providing highly controlled and uniform coverage. This pattern ensures clarity and precision in both stage monitor applications and point-source reinforcement configurations. The system achieves a maximum linear sound pressure level of 132 dB, maintaining excellent control and stability.

The enclosure is constructed from multi-layer birch plywood and finished with ISO-flex paint, offering high structural rigidity, long-term durability, and effective protection against impacts and demanding conditions. An integrated pole-mount socket located within the carry handle allows the system to be used as a point-source solution when required.

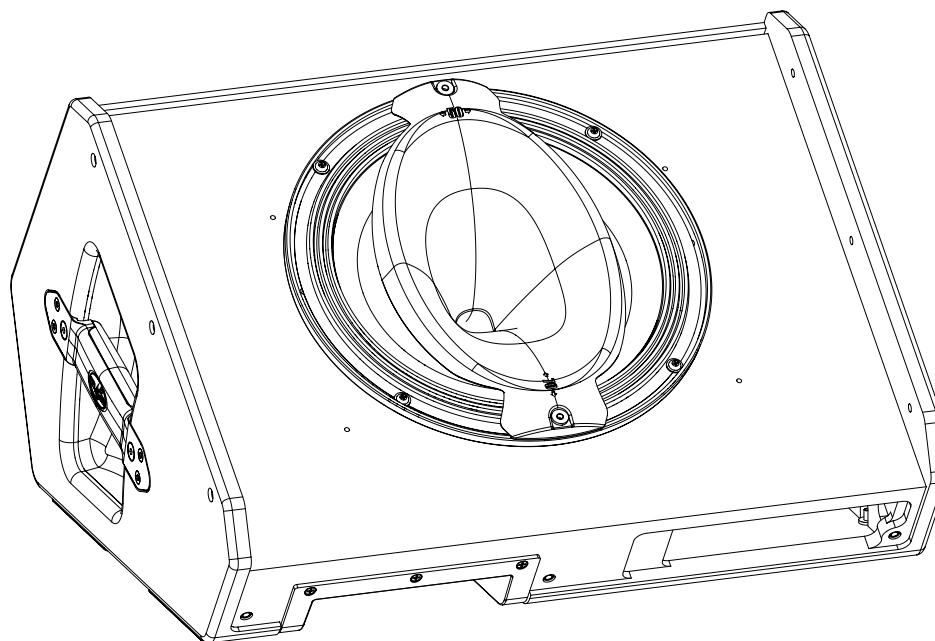

The EVENT-M12A incorporates a state-of-the-art digital signal processor with FIR filtering, ensuring constant phase response and full compatibility with the entire EVENT series, including the latest models as well as EVENT-26A, EVENT-28A, and EVENT-30A. The DSP platform, combined with integrated Wi-Fi connectivity, enables firmware updates via a web-server app, ensuring the system can gain new features and improvements over time.

The amplifier module and system connectors are located on the front of the enclosure, remaining out of the audience's line of sight when used on stage. This layout improves visual integration while also providing convenient access during setup and operation.

- » Ultra-compact, lightweight 12" coaxial powered stage monitor
- » High-efficiency Class D amplifier with 2000 W peak output
- » Universal Mains SMPS with front-hidden design — remains out of audience sight on stage
- » High-end 24-bit DSP with FIR filtering for constant phase response
- » 50° × 70° numerically optimized horn coverage (H x V)
- » 132 dB maximum linear SPL (136 dB peak)
- » Full compatibility with the entire EVENT series (including EVENT-26A, EVENT-28A, EVENT-30A AND SUBs)
- » Integrated Wi-Fi connectivity for firmware updates via web-server app
- » Multi-layer birch plywood enclosure with ISO-flex paint finish
- » Integrated pole-mount socket for point-source use

Connectors and controls

EVENT-M12A

The amplifier panel is recessed into the front face of the enclosure. When the EVENT-M12A is deployed as a stage monitor, this panel faces toward the stage floor and remains out of the audience's line of sight. The panel provides all audio and power connections required for system operation.

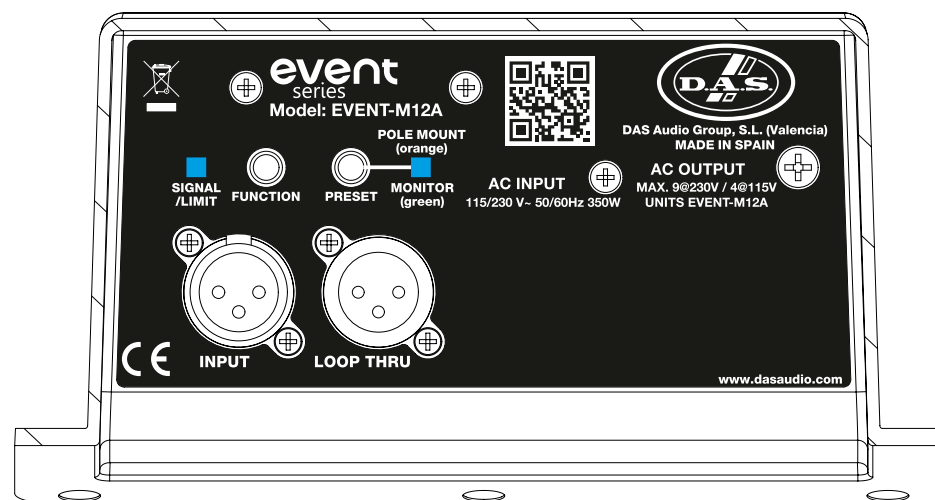

INPUT	Balanced audio signal input (female XLR). Connect the audio source or mixing console send here.
LOOP THRU	Balanced audio signal loop-through output (male XLR). Passes the input signal to additional units in the chain.
AC INPUT	Mains power input (powerCON NAC3MPA). Accepts 115/230 V~, 50/60 Hz. Power consumption: 350 W.
AC OUTPUT	Mains power loop-through (powerCON NAC3MPB). Daisy-chains power to additional EVENT-M12A units. Max: 9 units @230 V / 4 units @115 V.
SIGNAL/LIMIT LED	Indicates audio signal status. Illuminates to confirm active signal; changes state when the system limiter is engaged.
MONITOR / POLE MOUNT LED	Bicolor LED showing active mode. Green = stage monitor mode. Orange = pole-mount (point-source) mode.
FUNCTION Button	Multi-function control button. Press and hold to initiate a Wi-Fi firmware update via the built-in web-server app. Also used to perform a system reset. Refer to the DSP & Wi-Fi section for detailed procedures.
PRESET Button	Selects the system operating preset. Toggles between Monitor mode (LED green) — optimized for stage floor monitoring — and Point-Source mode (LED orange) — dedicated DSP processing for pole-mounted point-source reinforcement. The active mode is indicated by the MONITOR / POLE MOUNT LED. See the Configurations section for full details on each preset.

Installation

Monitor mode

In Monitor Mode, the EVENT-M12A is placed on the stage floor in the wedge position with the grille angled towards the performer. The trapezoidal geometry of the enclosure provides a natural wedge angle optimized for on-stage near-field monitoring. The amplifier panel and all connectors face the stage floor, keeping cables out of the audience's sightline and allowing easy access for the monitor engineer from the side of the stage.

Select Monitor Mode by pressing the PRESET button until the MONITOR / POLE MOUNT LED turns green. The DSP applies processing calibrated for near-field stage use: frequency response, level alignment, and dynamic management are tuned for the acoustic conditions typical of floor monitoring, including floor-coupling and proximity to the performer.

Pole mount mode

In Pole Mount Mode, the EVENT-M12A is mounted vertically on a standard speaker pole stand for use as a point-source speaker pole stand for use as a point-source PA or fill speaker. Insert the pole into the integrated socket located within the carry handle of the enclosure. Always use a stand rated for the weight of the unit (21 kg / 46.3 lb) and verify all couplings are fully secured before operation. Do not leave a pole-mounted unit unattended in locations accessible to the public without additional securing measures.

Select Pole Mount Mode by pressing the PRESET button until the MONITOR / POLE MOUNT LED turns orange. The DSP applies dedicated processing calibrated for vertical deployment: EQ, dispersion compensation, and dynamic management are adjusted for horizontal coverage toward the audience, delivering optimal tonal balance and SPL uniformity for point-source reinforcement.

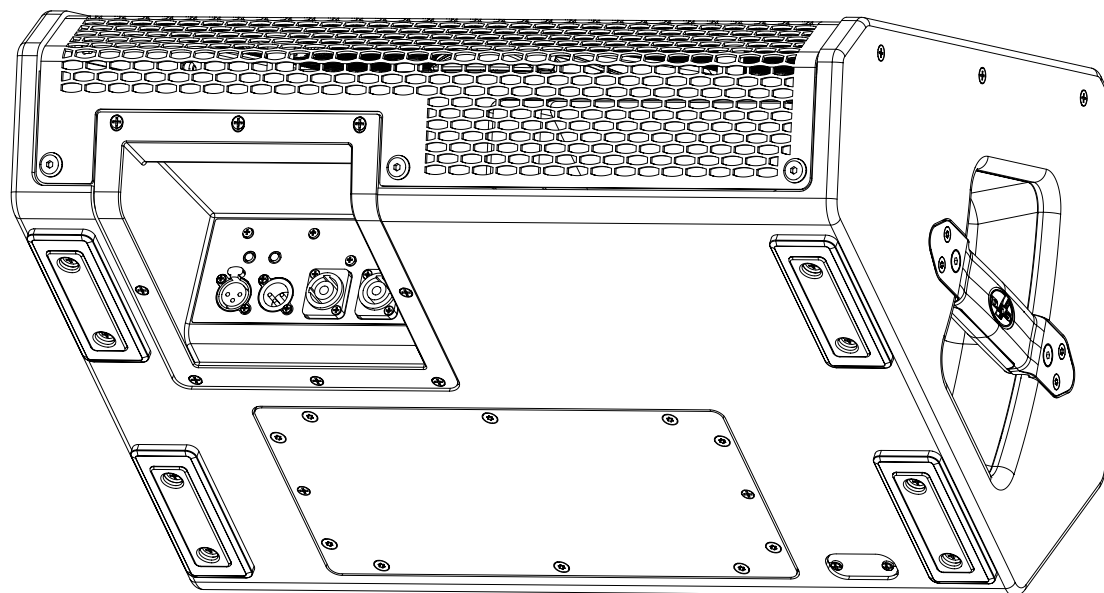

Configurations

The following diagrams show the three main system configurations for the EVENT-M12A. Each configuration requires a different cable routing; ensure the correct preset is selected on the EVENT-M12A using the PRESET button before operation. Refer to the Installation section for preset details.

Configuration 1

Point-Source System (Pole Stand)

Two EVENT-M12A units pole-mounted in stereo, driven from a mixing console. Connect the left XLR output of the console to the INPUT of the left EVENT-M12A, and the right XLR output to the INPUT of the right EVENT-M12A. Power each unit independently via its AC INPUT (powerCON NAC3MPA), or daisy-chain from one unit to the other via the AC OUTPUT (powerCON NAC3MPB) — see Power Daisy-Chaining for limits. Select Pole Mount Mode (LED orange) on both units.

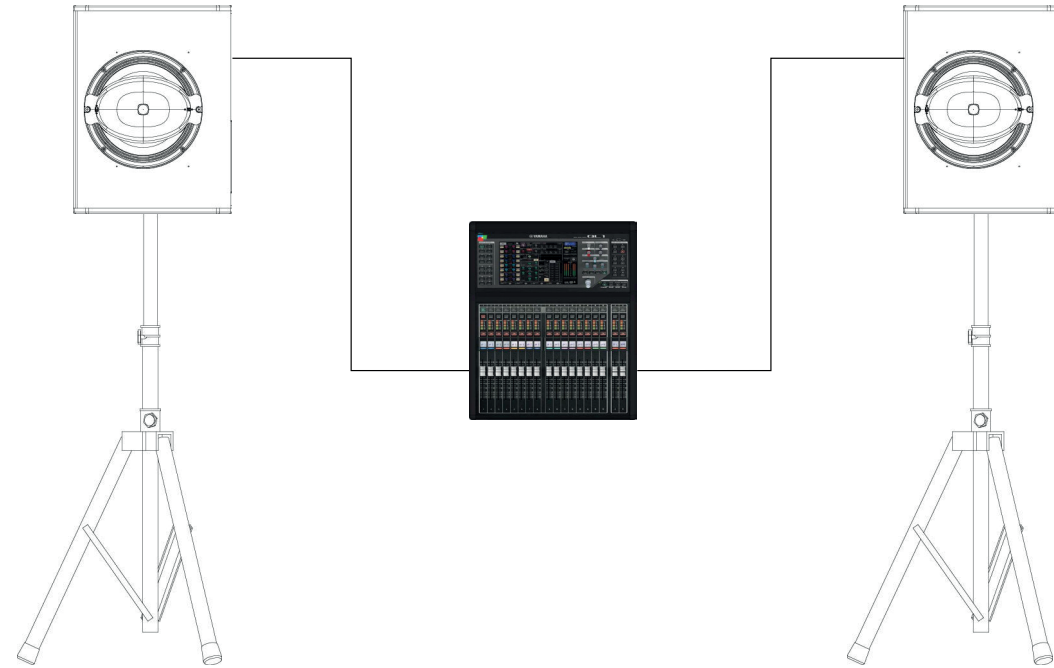

Configurations

The following diagrams show the three main system configurations for the EVENT-M12A. Each configuration requires a different cable routing; ensure the correct preset is selected on the EVENT-M12A using the PRESET button before operation. Refer to the Installation section for preset details.

Configuration 2

EVENT-M12A + EVENT-115A Subwoofer

Two EVENT-M12A units pole-mounted above two EVENT-115A subwoofers, driven from a mixing console. Connect the left and right XLR outputs of the console to the INPUT of each EVENT-115A. Route the LOOP THRU output of each EVENT-115A to the INPUT of the corresponding EVENT-M12A mounted above it. The DSP in each unit applies the appropriate crossover and processing for its frequency band — no external processor or crossover is required. Power each unit independently, or daisy-chain AC power from the EVENT-115A AC OUTPUT to the EVENT-M12A. Select Pole Mount Mode (LED orange) on the EVENT-M12A units.

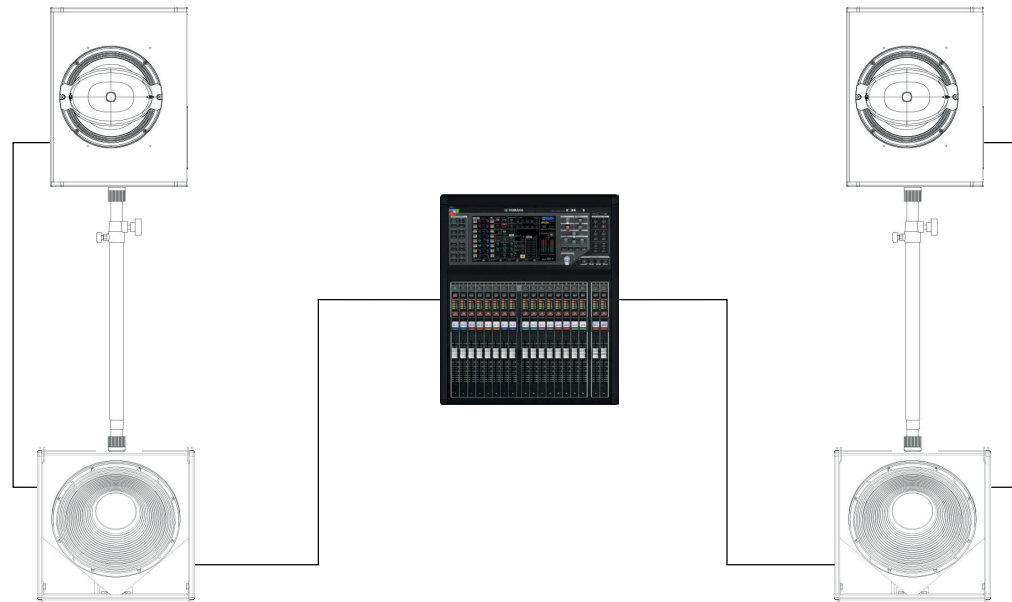

Configurations

The following diagrams show the three main system configurations for the EVENT-M12A. Each configuration requires a different cable routing; ensure the correct preset is selected on the EVENT-M12A using the PRESET button before operation. Refer to the Installation section for preset details.

Configuration 3

EVENT-M12A + EVENT-118A Subwoofer

Two EVENT-M12A units pole-mounted above two EVENT-118A subwoofers, driven from a mixing console. Connection procedure is identical to Configuration 2: console outputs connect to the EVENT-118A INPUTs, and the LOOP THRU of each EVENT-118A feeds the corresponding EVENT-M12A. The EVENT-118A's larger 18" driver extends low-frequency output for applications requiring higher bass SPL. Power each unit independently or via AC daisy-chain. Select Pole Mount Mode (LED orange) on the EVENT-M12A units.

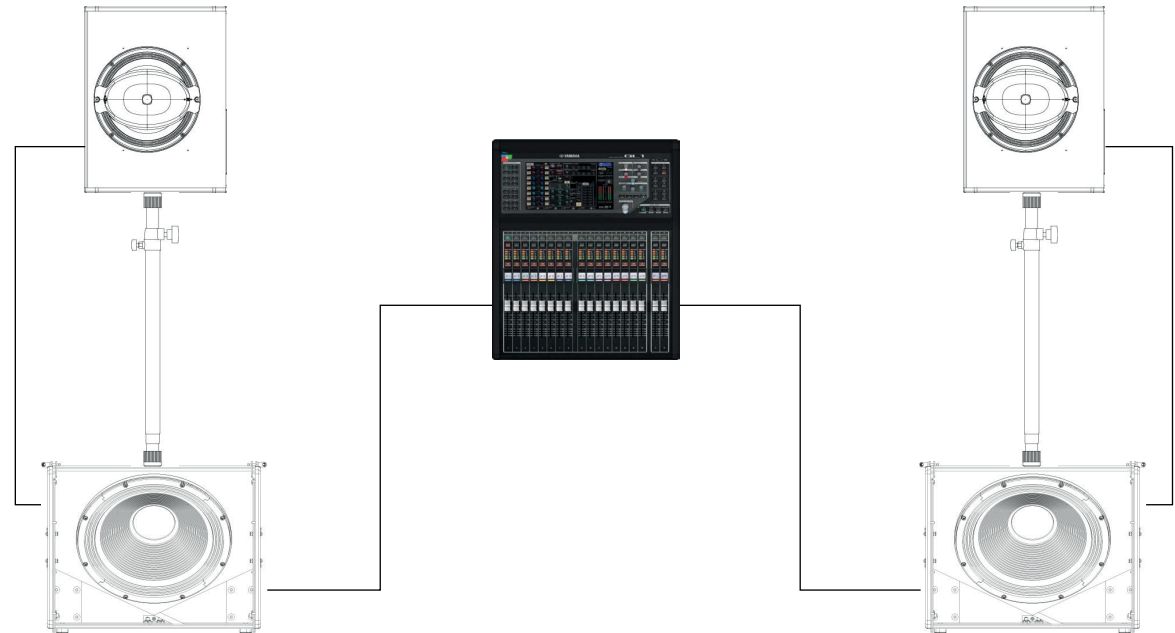

DSP & Wi-Fi

The EVENT-M12A incorporates a high-end 24-bit DSP with FIR filtering, providing a constant phase response across the operating bandwidth. The DSP is pre-configured for optimized performance with the EVENT series and requires no user adjustment for standard operation.

The system includes integrated Wi-Fi connectivity that enables access to a built-in web-server app. This interface allows for firmware updates, ensuring the EVENT-M12A can receive new features and improvements over time without specialist hardware. To connect, enable Wi-Fi on a smartphone, tablet, or laptop and follow the connection procedure described below.

The DSP platform ensures full system compatibility across the EVENT series, including EVENT-26A, EVENT-28A, EVENT-30A and subwoofers facilitating seamless integration in mixed EVENT series deployments.

Firmware Update Procedure

- » Power on the EVENT-M12A and allow the system to fully initialize.
- » To enable WiFi server press FUNCTION Button while power the system on.
- » On a Wi-Fi-enabled device, scan for available networks and connect to the network broadcast by the EVENT-M12A.
- » Open a web browser and navigate to the address 192.168.4.1.
- » Follow the on-screen instructions in the web-server app to check for and apply available firmware updates.
- » Do not power off the unit during a firmware update. Allow the process to complete fully before disconnecting power.
- » After connecting to the unit, to go back and operate the monitor in normal conditions, power off and on the unit.

Specifications

Performance

Frequency Range (-10 dB)	60 Hz – 20 kHz
Horizontal Coverage (-6 dB)	50°
Vertical Coverage	70°
Maximum Linear SPL ¹	132 dB
Maximum SPL ²	136 dB

Electronics & Connectors

Nominal Amplifier Power (continuous)	60 Hz – 20 kHz
Nominal Amplifier Power (peak)	50°
Nominal Amplifier Power LF (continuous)	70°
Nominal Amplifier Power LF (peak)	132 dB
Nominal Amplifier Power HF (continuous)	136 dB
Nominal Amplifier Power HF (peak)	300 W
Input Type	Balanced
Input Impedance	20 k Ω
Input Sensitivity	6.2 V (+18 dBu)
Audio Signal Input Connector	1 x Female XLR
Audio Signal Loop Thru Connector	1 x Male XLR
AC Input Connector	powerCON NAC3MPA
AC Output Connector	powerCON NAC3MPB

¹ Measured Maximum Linear SPL at 1 m according to AES75 standard using 18 dB crest factor M-Noise.

² Measured Maximum SPL at 1 m using burst noise.

Enclosure

Construction	Multi-layer birch plywood
Geometry	Trapezoidal
Finish	ISO-flex Paint
Color	Black
Dimensions (H × W × D)	335 × 555 × 475 mm / 13.1 × 21.8 × 18.7 in
Net Weight	21.0 kg / 46.3 lb

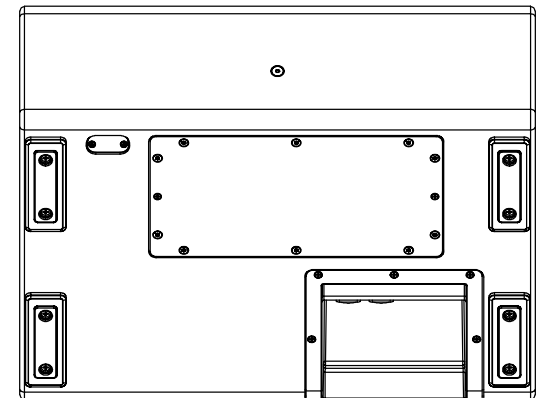
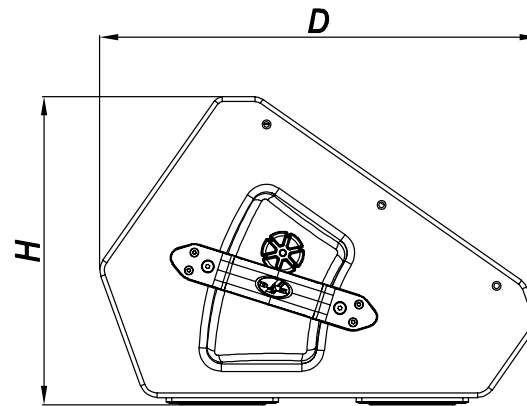
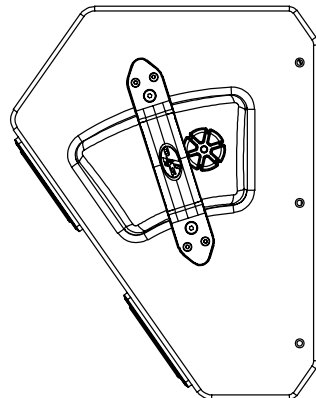
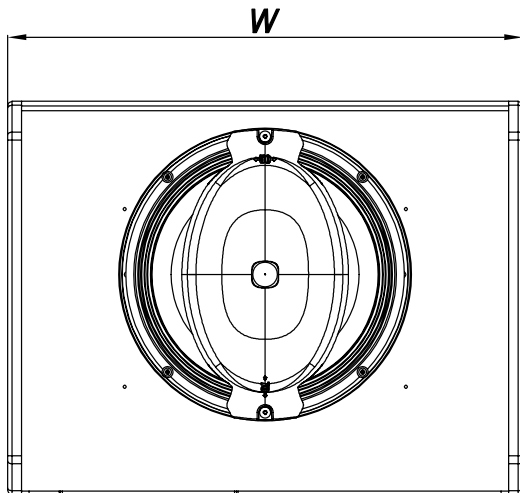

Ordering Information

	Description	P/N
System		
EVENT-M12A	—	15004757
Replacement parts		
DSP-EVENT-M12A	DSP Module	25005277
MP-EVENT-M12A	Power Module	25005234
S-PRO2	Amplifier	20406649
Accessories		
PWCONLINK-09	powerCON Link Cable	20502210
SC-05	Speaker Cable	20501010
TRD-2-PACK	Installation & Stacking Accessory	10104012
TRD-7	Installation & Stacking Accessory	10104471
TRD-8	Installation & Stacking Accessory	15004940



DAS Audio Group, S.L.

C/ Islas Baleares, 24
46988. Fuente del Jarro
Valencia - Spanien
Tel. +34 961 340 860

DAS do Brasil Ltd.

Rua Dos Andradas, 382 SL
Santa Efigênia, São Paulo
Brasilien. CEP: 01208-000
Tel. +551133330764

DAS Audio of America, Inc.

6900 NW 52nd Street Miami, FL 33166
– U.S.A
Tel. +1 305-436-0521

DAS Audio China

Han Kou Road 309, Room 302
Huang Pu District
上海市黄浦区汉口路309号302室
200001 – Shanghai – China
Tel. +86 21 5169 0869

DAS Audio Asia PTE. LTD.

9 Gray Lane 03-01
Signature Crest
Singapore 438951
Tel. +65-9739-5000

DAS Audio GmbH

Mülheimer Str. 48
53840 Troisdorf
Germany
Tel. +49 2241 945880

