

Parts List

ITEM	QTY	PART NUMBER	DESCRIPTION
1	2	10KY	DRIVE KEY
2	1	028-188	SHCS 1/2-20-1 1/4
3	1	10LS	LOCK SCREW

THIS DRAWING IS FOR CUSTOMER APPROVAL ONLY

RETURN FAX: 1-800-866-5917

PLEASE NOTE: 1) PARLEC WARRANTS ALL STANDARD TOOLING AND/OR COMPONENTS. ON ALL SPECIAL CUSTOMER DEFINED TOOLS AND COMPONENTS, PARLEC WARRANTS ONLY THE ACCURACY OF THE SPECIFICATIONS NOTED ON THE APPROVAL DOCUMENT. THE FUNCTIONALITY OF CUSTOMER DEFINED COMPONENTS (SPECIALS) ARE SOLELY THE RESPONSIBILITY OF THE CUSTOMER. 2) PRICING & DELIVERY IS BASED ON THIS CONCEPT. ANY CUSTOMER CHANGES DURING THE APPROVAL PROCESS MAY RESULT IN CHANGES TO PRICE AND LEAD-TIMES.

SIGNATURE \_\_\_\_\_

DATE \_\_\_\_\_

WAS 6175270  
8.00" WAS 8.50"  
APPROVAL REQUIRED

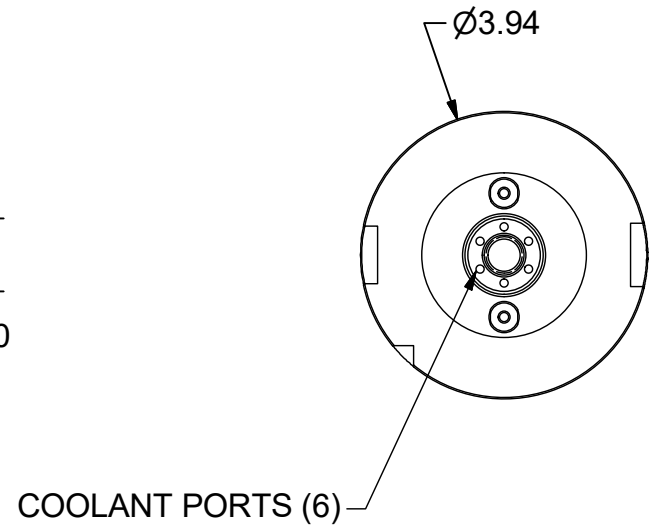
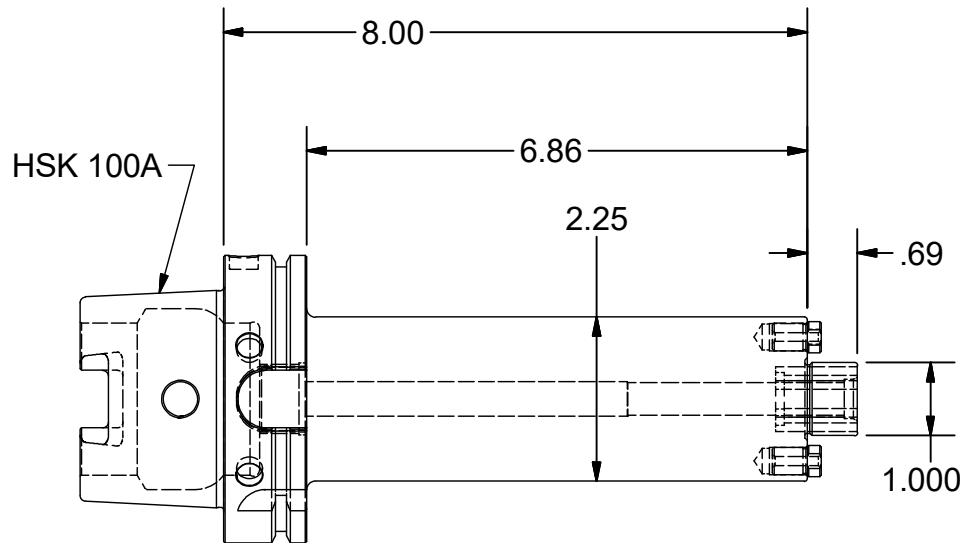
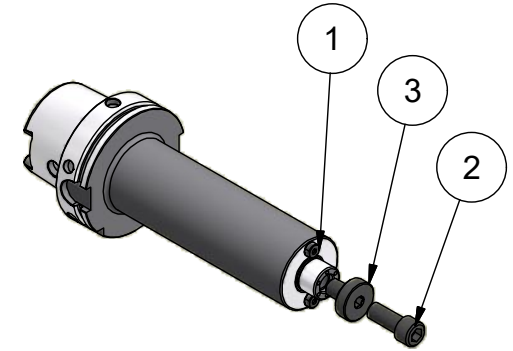

PRE-BALANCE: G2.5 @ 12,000 RPM

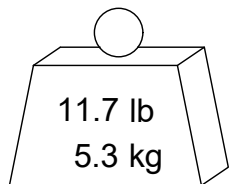

BOEING TDM 00011727

PART  
NUMBER

H100A-10SM800C

**PARLEC**  
(800) TOOL USA  
WORLD HEADQUARTERS  
101 PERINTON PARKWAY  
FAIRPORT, NEW YORK 14450