



Ice dispenser self-contained - Pebble system Daily production up to 105 kg

Hotel	████████████████████
Restaurant	██████████████████
Fast food	██████████████████
Bar	██████████████████
Disco	██████████████████
Fish market	██████████████████
Supermarket	██████████████████
Medical & SPA	██████████████████
Industry	██████████████████

► Position n°



► Features & Plus

- Pebble ice - 91% dry
- 1l (water) - 1kg (ice) - only Air cooled
- AISI 304 SS Scotch Brite finish
- Tropical class +43°C
- AISI 304 SS evaporator
- Air cooling system
- HCFC-Free insulated storage
- Dust-proof water basin
- RoHS Free
- Electromechanical operation
- Automatic water charge
- Standard voltages
- HFC Free



360° innovative design

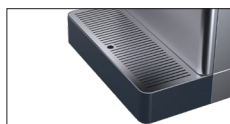

Removable and cleanable basin



Hidden cables to exalt the aesthetics



Spokes with harmonic proportions

► Available pebble size

drawing for reference only

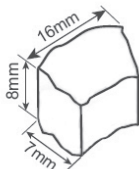

► Prod. 24h

Air temp.		Water temp.		kg	lbs
10° C	50° F	7° C	45° F	105	231
21° C	70° F	15° C	60° F	90	198

2 Years Warranty
subject to limitations

► Certifications available for this model





Ice Pebbles

BSF



Ice dispenser self-contained - Pebble system Daily production up to 105 kg

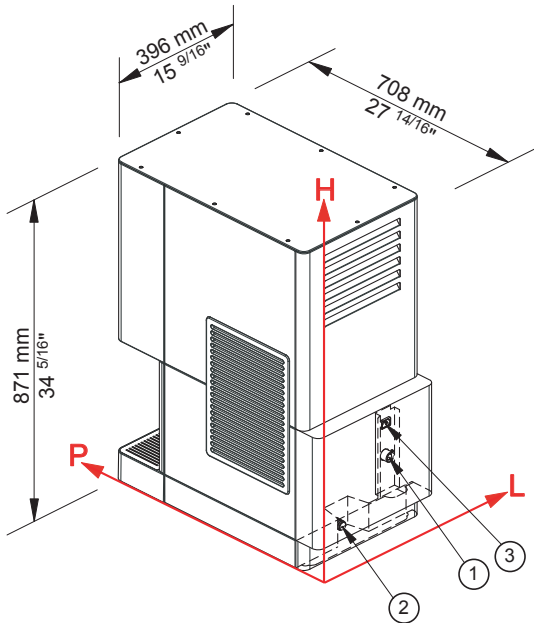

▶ Working conditions

- Location: **Indoor**

	Min	Max
Ambient temperature	+10° C / +50° F	+43° C / 110° F
Water temperature	+3° C / +37° F	+32° C / +90° F
Voltage	-10%	+10%
Water inlet pressure	1bar (14 psi)	6bar (84 psi)

▶ Performances

	Air temperature	Water temperature	Water temperature				
			7° C	45° F	15° C	60° F	21° C
	10° C	105 kg					
	50° F	231 lbs					
	21° C		90 kg				
	70° F			198 lbs			
	32° C				80 kg		
	90° F					176 lbs	

▶ Connections *

All measures are referred to the rear bottom-left corner (L-H-Ø)

- ① Water in.: 317 mm / 12 8/16" - 173,5 mm / 6 13/16" - 3/4"
- ② Water out.: 195 mm / 7 11/16" - 19,5 mm / 12/16" - 24 mm / 15/16"
- ③ Electrical connections: 317 mm / 12 8/16" - 261 mm / 10 4/16"

* Consult the user manual to correctly position the connection inside the specific panel and respect the design of the dispenser

▶ Technical information

Production in 24h	90 kg / 198 lbs	Electrical consumption	19 Kw/h/100 kg
Storage capacity, up to	5 kg / 11 lbs	Water consumption	A: 1 l/kg - 12,0 gal/100 lbs
Cooling system	A	Sizes (L-P-H mm)	396 - 708 - 871
Approximate pebble size	8 x 16 x 7	(L-P-H in)	15 9/16 - 27 14/16 - 34 5/16
Refrigerant	R290	Sizes with pack (L-P-H mm)	465 - 770 - 1040
Standard voltage	220-240 V ~ 50 Hz	(L-P-H in)	18 5/16 - 30 5/16 - 40 15/16
Average power consumption	440 W	Net weight	61 kg / 134 lbs
Fuse	10 A	Gross weight	71,5 kg / 158 lbs
Delivered ice	50 g/sec	Finish	AISI 304 stainless steel, scotch brite

All the technical information must be considered at the following conditions:
 Ambient temperature +21° C
 Water temperature +15° C
 Electrical consumption at +32° C (standard voltage)
 Average power consumption at +43° C (standard voltage)

Models and specifications are subject to change without notice

Rev. 03 - Issued January 2025



www.bremagroup.it
info@bremaicegroup.it

We are Brema

