



**Self-contained ice maker - Sprayer system**  
Daily production up to 46 kg

|               |                      |
|---------------|----------------------|
| Hotel         | ████████████████████ |
| Restaurant    | ██████████████████   |
| Fast food     | ██████████████       |
| Bar           | ████████████████████ |
| Disco         | ████████████████████ |
| Fish market   | ██████████████       |
| Supermarket   | ██████████████       |
| Medical & SPA | ██████████████       |
| Industry      | ██████████████       |

► Position n°



► Features & Plus

- Compact and crystal cube
- AISI 304 SS Scotch Brite finish
- Tropical class +43°C
- Air or water cooling system
- Easy cleanable internal rounded surfaces
- HCFC-Free insulated storage
- RoHS Free
- Electromechanical operation
- Standard and special voltages
- Ice dispenser
- HFC Free



AISI 304 SS Scotch Brite finish



Ice dispenser

► Available ice cube size



► Prod. 24h

| Air temp. | Air temp. |       | Water temp. |       | kg  | lbs |
|-----------|-----------|-------|-------------|-------|-----|-----|
|           | 10° C     | 50° F | 7° C        | 45° F |     |     |
| 10° C     | 50° F     | 7° C  | 45° F       | 46    | 101 |     |
| 21° C     | 70° F     | 15° C | 60° F       | 44    | 97  |     |

**2 Years Warranty**  
subject to limitations

► Certifications available for this model





Ice Cube

# DSS 42 HC



## Self-contained ice maker - Sprayer system Daily production up to 46 kg

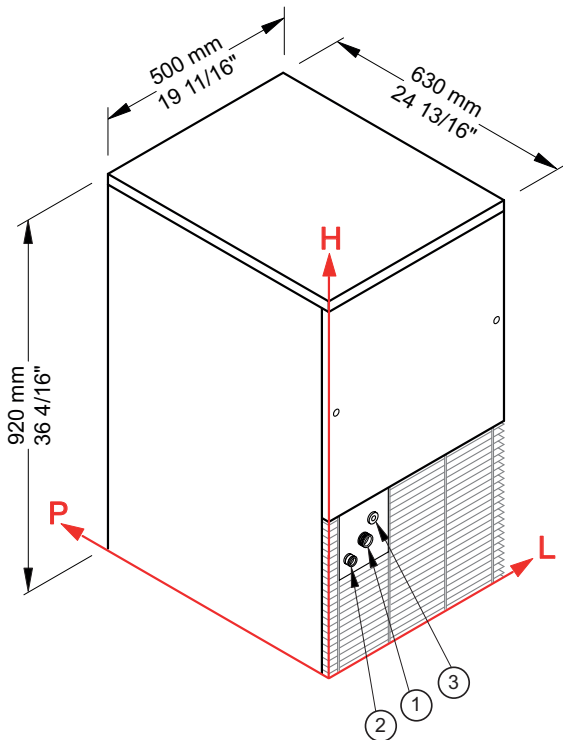

### ► Working conditions

- Location: **Indoor**

|                      | Min             | Max             |
|----------------------|-----------------|-----------------|
| Ambient temperature  | +10° C / +50° F | +43° C / 110° F |
| Water temperature    | +3° C / +37° F  | +32° C / +90° F |
| Voltage              | -10%            | +10%            |
| Water inlet pressure | 1bar (14 psi)   | 6bar (84 psi)   |

### ► Performances

|  | Air temperature | Water temperature |         |       |        |       |        |
|--|-----------------|-------------------|---------|-------|--------|-------|--------|
|  |                 | 7° C              | 45° F   | 15° C | 60° F  | 21° C | 70° F  |
|  | 10° C           | 46 kg             |         |       |        |       |        |
|  | 50° F           |                   | 101 lbs |       |        |       |        |
|  | 21° C           |                   |         | 44 kg |        |       |        |
|  | 70° F           |                   |         |       | 97 lbs |       |        |
|  | 32° C           |                   |         |       |        | 38 kg |        |
|  | 90° F           |                   |         |       |        |       | 84 lbs |

### ► Connections

All measures are referred to the rear bottom-left corner (L-H-Ø)

- ① Water in.: 111 mm / 4 6/16" - 311 mm / 12 4/16" - 3/4"
- ② Water out.: 49 mm / 1 15/16" - 270 mm / 10 10/16" - 24 mm / 15/16"
- ③ Electrical connections: 156 mm / 6 2/16" - 347 mm / 13 11/16"

### ► Technical information

|                           |                   |                            |  |
|---------------------------|-------------------|----------------------------|--|
| Production in 24h         | 44 kg / 97 lbs    | Water consumption          | A: 4 l/kg - 47,9 gal/100 lbs           |
| Store capacity, up to     | 12 kg / 26 lbs    | Sizes (L-P-H mm)           | 500 - 630 - 920                        |
| Cooling system            | A                 | (L-P-H in)                 | 19 11/16 - 24 13/16 - 36 4/16          |
| Kind of cube              | D-13g             | Sizes with pack (L-P-H mm) | 540 - 770 - 1090                       |
| Refrigerant               | R290              | (L-P-H in)                 | 21 4/16 - 30 5/16 - 42 15/16           |
| Standard voltage          | 220-240 V ~ 50 Hz | Net weight                 | 66 kg / 146 lbs                        |
| Average power consumption | 400 W             | Gross weight               | 74 kg / 163 lbs                        |
| Fuse                      | 10 A              | Finish                     | AISI 304 stainless steel, scotch brite |
| Delivered ice             | 3 kg/min          |                            |  |

All the technical information must be considered at the following conditions:

- Sizes without feet
- Standard Cube (13 g)
- Ambient temperature +21° C
- Water temperature +15° C
- Average power consumption at +43° C (standard voltage)

Models and specifications are subject to change without notice

Rev. 00 - Issued June 2025



[www.bremagroup.it](http://www.bremagroup.it)  
info@bremaicegroup.it

We are Brema

