

ISLAND AND HORIZONTAL



# GANDER 4



A  
R  
N  
E  
G

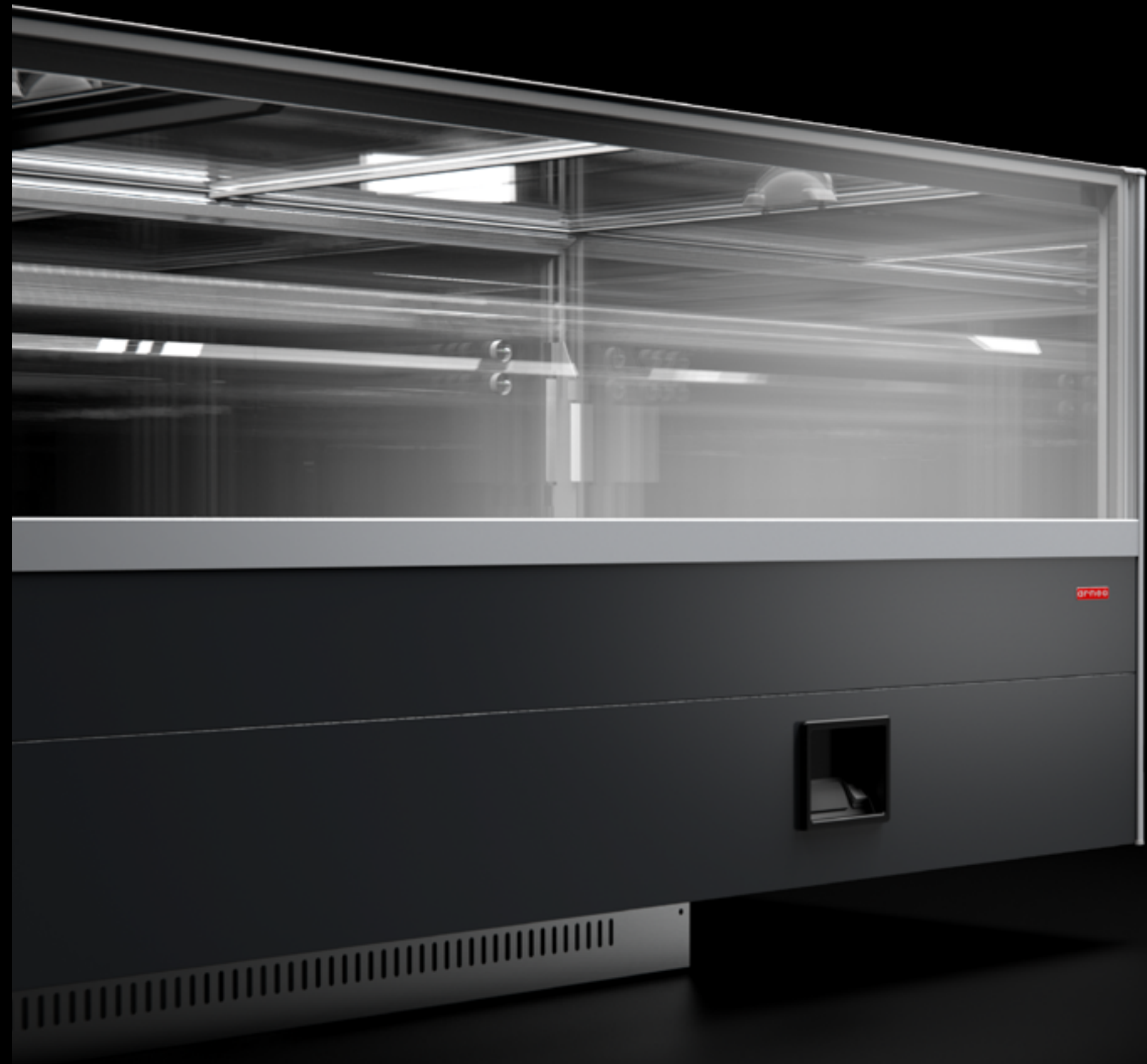

# AN ISLAND OF EFFICIENCY.

Efficiency, easy access, transparency, versatility and maximum freedom for customisation.

**Gander 4** closed, plug-in islands with sliding glass covers are ideal for self-service sales of a wide range of products, from frozen foods in the LT/NT version to meat, dairy and other products in the NT version.

# QUALITY WITHIN EASY REACH.

With its G2 and G4 sliding glass covers, these islands offer a panoramic view of the products on display. In addition, easy access from all sides combines with maximum transparency to encourage impulse buying and optimise the presentation of the latest promotions.



- Maximum transparency
- Excellent product visibility
- High load capacity



— GAS —  
**R290**  
— —  



# HIGH-PERFORMANCE, SUSTAINABLE REFRIGERATION.

R290 natural gas gives Gander 4 islands low environmental impact combined with excellent performance.



# VERSATILE DIMENSIONS.

To facilitate the organisation of space and satisfy multiple display needs, Gander 4 comes in 6 different lengths (880, 1200, 1500, 1800, 2000 and 2400 mm) and the 2000 mm version can even be used as an end unit.

# SPACE FOR STYLE AND COMMUNICATION.

The bottom panels can be customised to match the style of your store's décor and can be easily changed to suit the latest promotions. Gander 4 is therefore a useful and effective communication tool too.



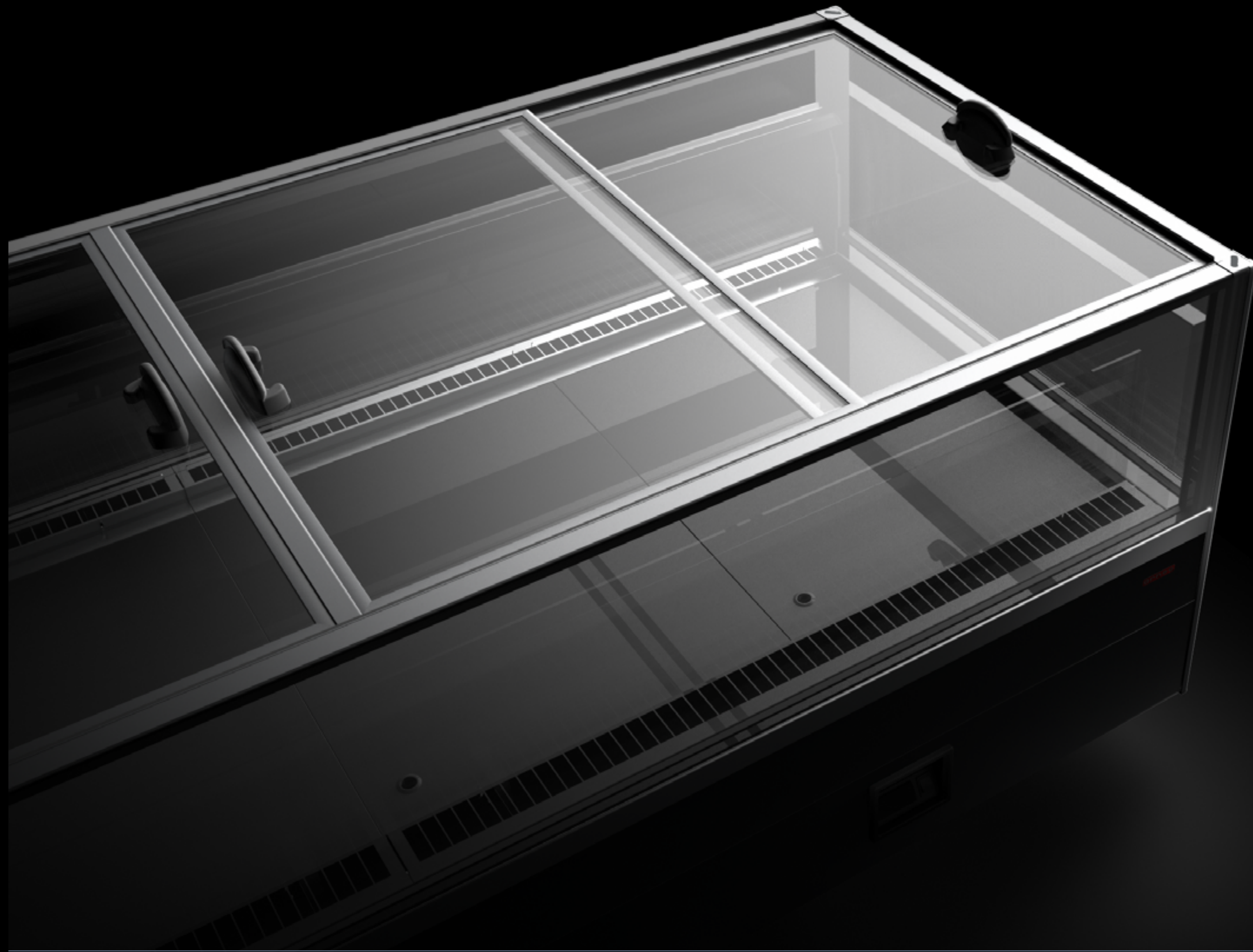

- **Energy saving thanks to R290 refrigerant.**
- **Ergonomic design for easy access to products.**
- **Different working temperatures.**
- **Maximum freedom for customisation.**



1

# ACCESSORIES

- 1 - Island wheels kit
- 2 - Rectangular bumper



2



3



4



5

3 - LED Light

4 - Wire basins partitions

5 - Bottom grilles

GANDER 4 ISL-C-1 BT V LINEARE I

External length (mm)	<b>1026</b>		<b>1345</b>		<b>1645</b>		<b>1945</b>		<b>2135</b>		<b>2545</b>	
Height of glass front	<b>G2</b>	<b>G4</b>	<b>G2</b>	<b>G4</b>	<b>G2</b>	<b>G4</b>	<b>G2</b>	<b>G4</b>	<b>G2</b>	<b>G4</b>	<b>G2</b>	<b>G4</b>
Temperature class	3L1	•	•	•	•	•	•	•	•	•	•	•
Preservation temperature (°C)	-22/-25	•	•	•	•	•	•	•	•	•	•	•
Refrigerant	R290	•	•	•	•	•	•	•	•	•	•	•
Horizontal display area* (m²)	0,7	0,69	0,96	0,94	1,2	1,18	1,44	1,41	1,59	1,56	1,92	1,88
Energy class**	A+ G <b>D</b>		A+ G <b>D</b>		A+ G <b>D</b>		A+ G <b>D</b>		A+ G <b>D</b>		A+ G <b>D</b>	

\*Value referred to illustrated configurations. \*\*The energy class may vary depending on the product configuration.

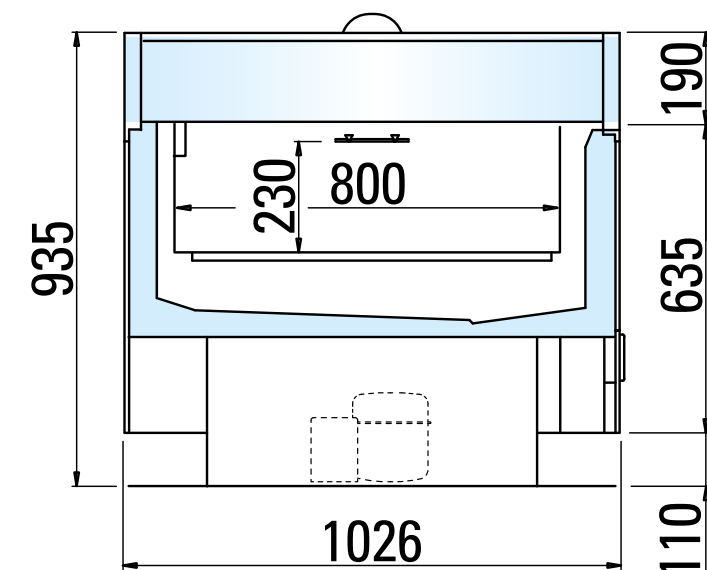
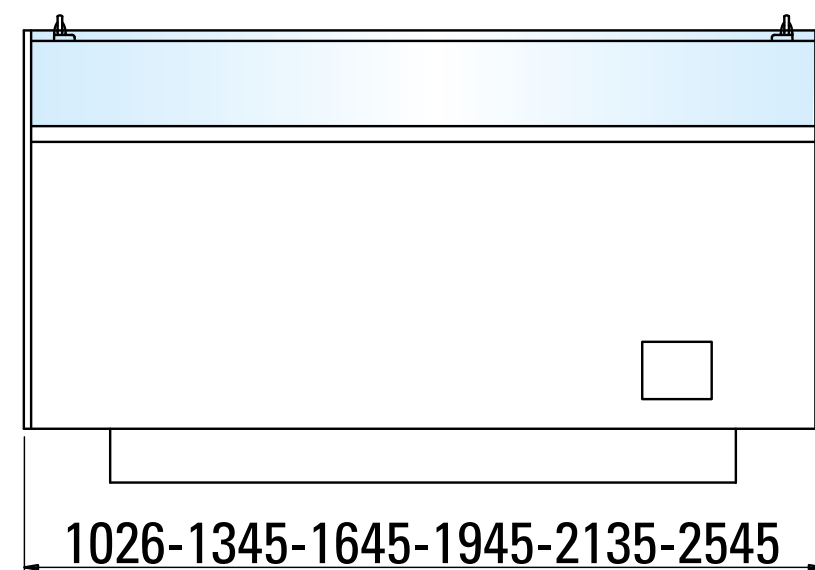

G2

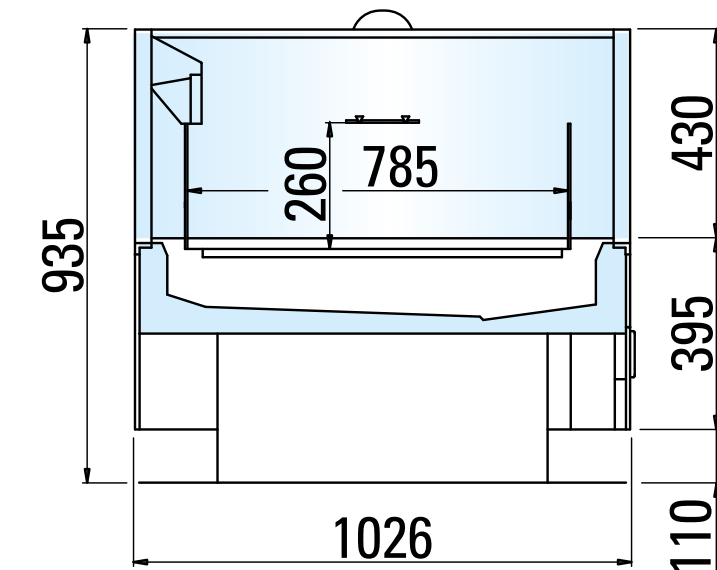
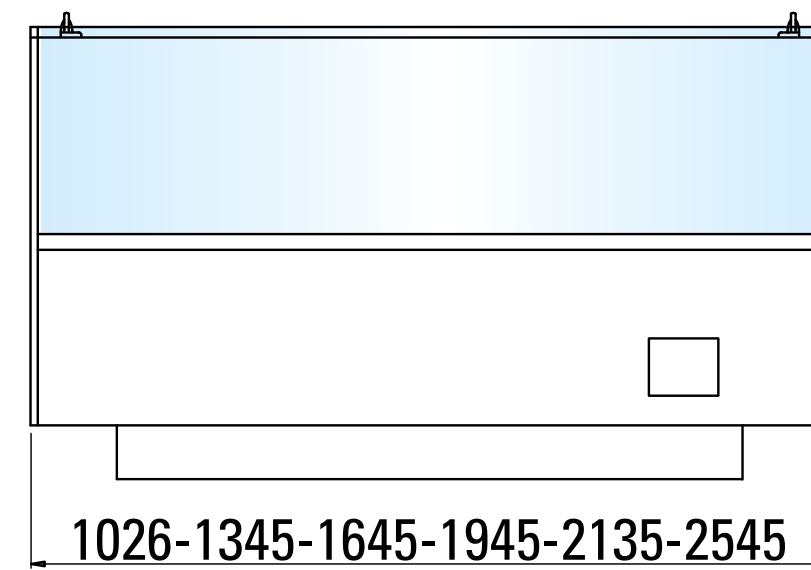

G4

GANDER 4 ISL-C-1 TN V LINEARE I

External length (mm)		<b>1026</b>	<b>1345</b>		<b>1645</b>		<b>1945</b>		<b>2135</b>	<b>2545</b>	
Height of glass front		<b>G4</b>	<b>G2</b>	<b>G4</b>	<b>G2</b>	<b>G4</b>	<b>G2</b>	<b>G4</b>	<b>G4</b>	<b>G2</b>	<b>G4</b>
Temperature class	3M1	•	•		•		•		•		•
Preservation temperature (°C)	0/+2	•	•		•		•		•		•
Refrigerant	R290	•	•		•		•		•		•
Horizontal display area* (m²)		0,7	0,96	0,94	1,2	1,18	1,44	1,41	1,56	1,92	1,88
Energy class**											

\*Value referred to illustrated configurations. \*\*The energy class may vary depending on the product configuration.

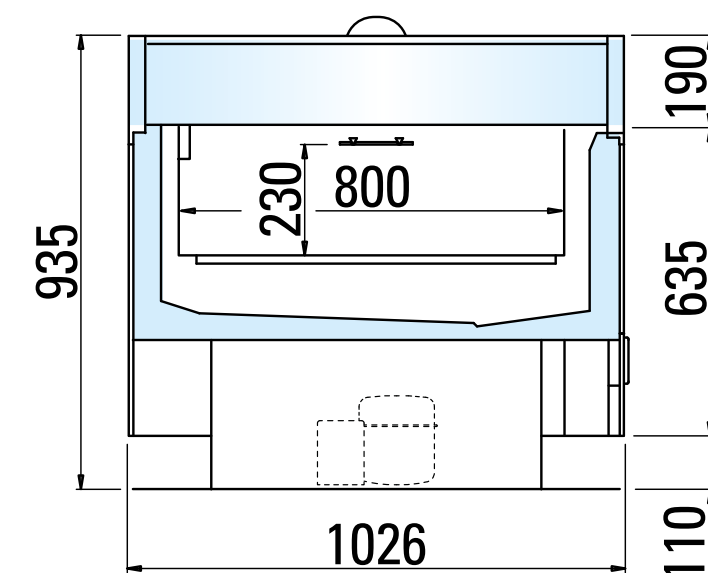
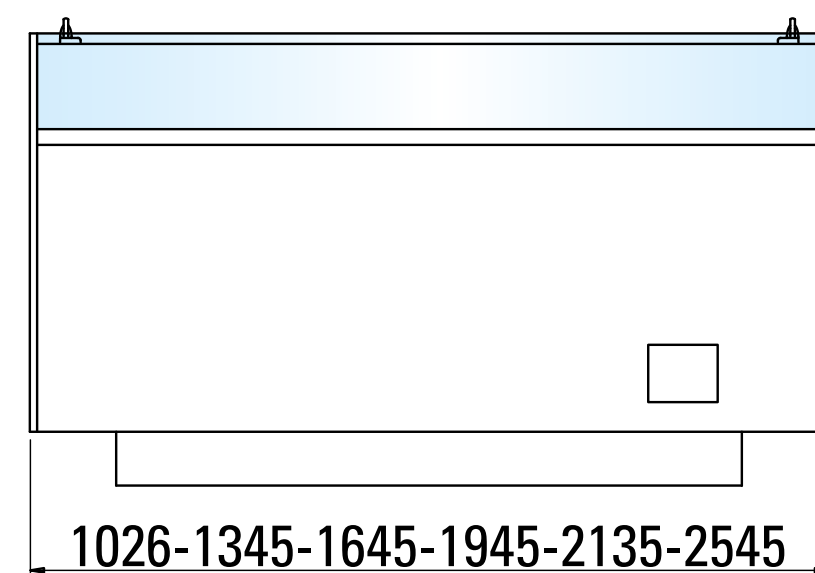

G2

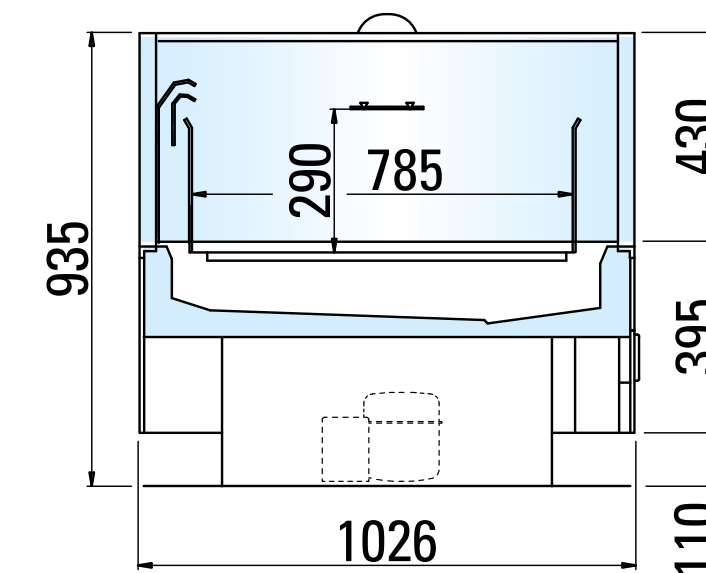
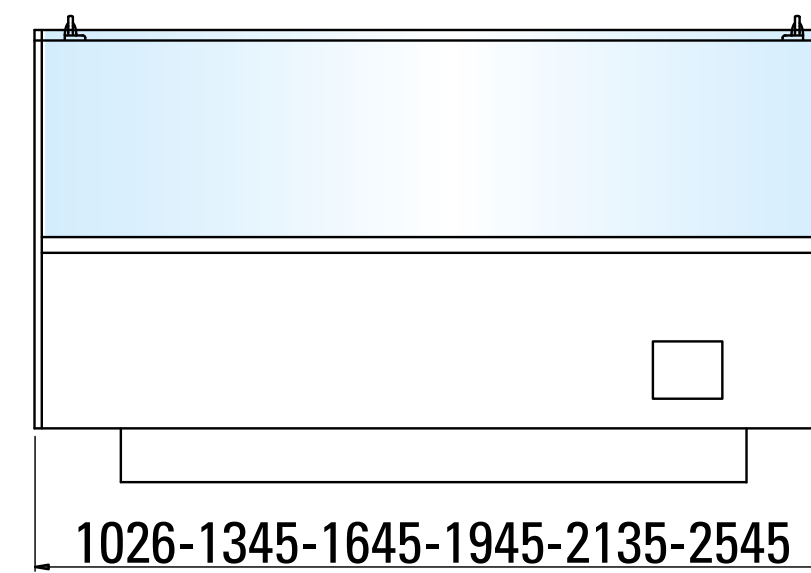

G4

ED. 02 - 03/09/2025

**arneg**

Your Global Partner for Retail Solutions



[www.arneg.com](http://www.arneg.com)

Arneg follows a policy of continuous improvement and reserves the right to update this document at any time without prior notice.