

Standard Installation



Flammable



Warning



High Voltage



Hot Surface

| | |
|----------------------|-----------------------------------|
| TOOLS NEEDED: | 1/16", 3/32" & 5/32" Allen Wrench |
| | Waterproof Wire Connectors |

INSTRUCTIONS PERTAINING TO A RISK OF FIRE, OR INJURY TO PERSONS IMPORTANT SAFETY INSTRUCTIONS

Lighted fixture is HOT!

WARNING - To reduce the risk of FIRE OR INJURY TO PERSONS:

Turn off/unplug and allow to cool before replacing lamp/LED. Fixture gets HOT quickly! Contact only switch/plug when turning on. Do not touch hot lens, guard, or enclosure. Keep fixture away from materials that may burn. Do not operate the luminaire fitting with a missing or damaged shield. Do not touch the source at any time. Use a soft cloth or gloves. Oil from skin may cause damage.

SAVE THESE INSTRUCTIONS

IMPORTANT SAFETY INFORMATION - READ, FOLLOW, AND SAVE ALL SAFETY AND INSTALLATION INSTRUCTIONS

- Product must be installed by a qualified person in a manner consistent with its intended use and in compliance with the National Electrical Code, Canadian Electrical Code, and all Local and Provincial Codes.
- Follow product label information and instructions.
- Qualified Personnel with appropriate personal protective equipment must perform all servicing of this product.
- Before wiring to power supply and during servicing, turn off and lock out power at fuse or circuit breaker before service.
- The use of accessory equipment not recommended by the manufacturer or installed contrary to instructions may cause an unsafe condition. The use of damaged components may cause an unsafe condition and void product warranty.
- Do not block light emanating from product in whole or part, as this may cause an unsafe condition.
- Never operate the fixture with missing or damaged lens. Lens must be cleaned on regular basis.
- Entire fixture may become extremely hot. Do not touch hot lens or fixture body.
- Replace LED assembly only with correct wattage and type of power supply appropriate for LED assembly.
- All gaskets, o-rings and sealing surfaces must be kept clean during installation and service; failure to do this may cause an unsafe condition and void product warranty.

IMPORTANT LISTINGS AND CERTIFICATIONS

- Suitable for wet locations

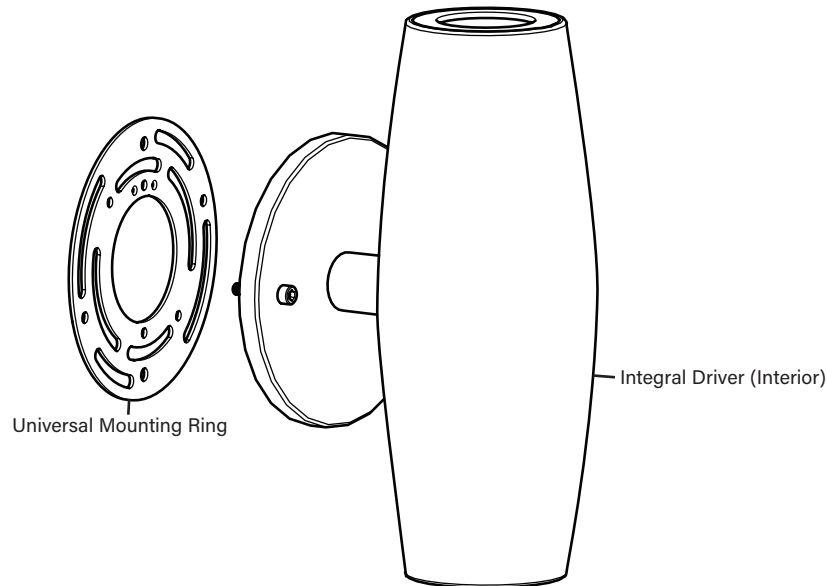

RIO WALL MOUNT DUAL

IMPORTANT SAFETY INFORMATION - READ, FOLLOW, AND SAVE THESE INSTALLATION INSTRUCTIONS

B-K LIGHTING

40429 Brickyard Drive • Madera, CA 93636 • USA
559.438.5800 • FAX 559.438.5900
www.bklighting.com • info@bklighting.com

RELEASE DATE
10/03/2025

REFERENCE NUMBER
INS-2904-00

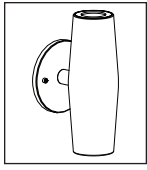

Standard Installation

Phase 1 - Rough In
Installation of Back box

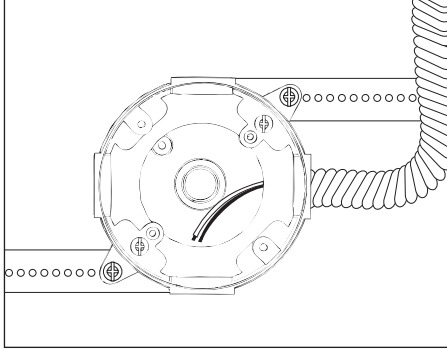

Additional Info

- Please follow National and Local electrical codes for your area.
- Use 4" round cast box (not included).
- Suitable for through wire.
- Suitable for installation into combustible materials.
- Rated for 90° C.
- Junction box, universal mounting ring screws, box mounting hardware and gaskets (not included).

1. Install conduit (not included) to be used with this product.
2. Install junction box so that front face is flush with finished wall or ceiling. Seal building envelope as per NEC.
3. Connect box to conduit and pull wires for connections (**See wiring diagram**).

Phase 2 - Finish Installation of Fixture with Remote Driver

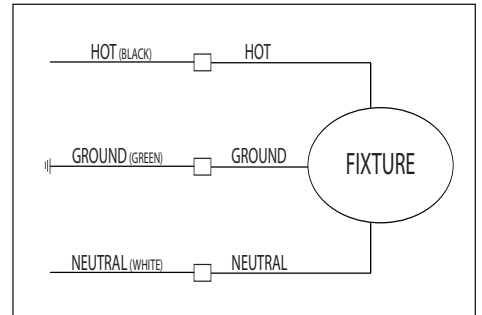
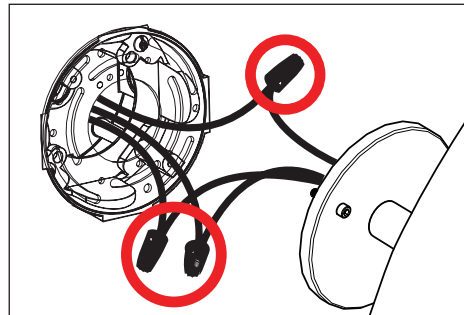
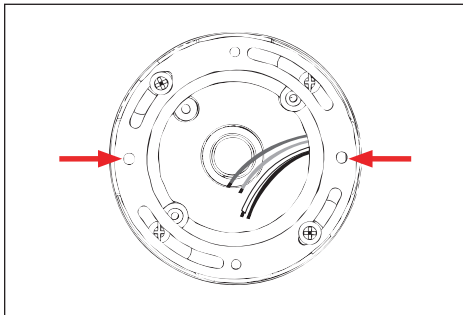

1. Install universal mounting ring (included with fixture) using #10-24 screws onto back box. Align fixture mounting holes to final mounting position.
2. Make watertight connections from remote driver to fixture source leads using waterproof wire connectors (not included). **See wiring diagram.**

WIRING DIAGRAM

3. Pull branch circuit wiring. Make watertight connections from branch circuit wiring to fixture leads using waterproof wire connectors (not included) in splice location as per NEC. UL Listed splice location required. Connect incoming green ground wire to ground wire from fixture. **See wiring diagram.**

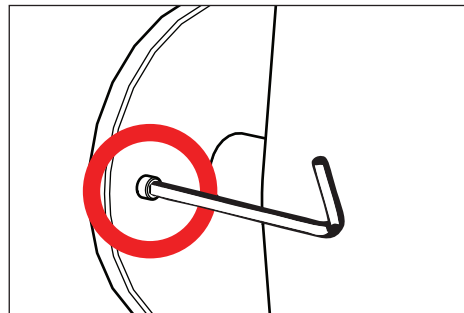
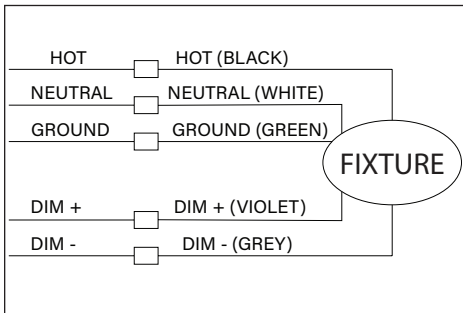

⚠ All line voltage connections must be made in compliance with the National Electrical Code. Failure to do so will void warranty.

WIRING DIAGRAM (0-10)

4. Mount fixture using two (2) #10-24 hex screws to installed back box. **Seal building envelope as per NEC. Do not overtighten.**

**IMPORTANT SAFETY INFORMATION LISTED ON REVERSE
READ, FOLLOW, AND SAVE ALL SAFETY AND INSTALLATION INSTRUCTIONS**



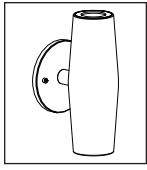

Standard Installation

Replacing LED Board/Driver and Optics

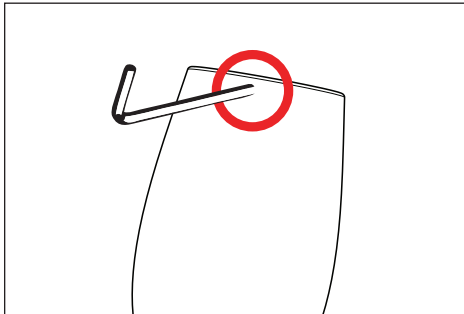

1. Use a 1/16" allen wrench to loosen #6-32 stainless set screw and remove cap.

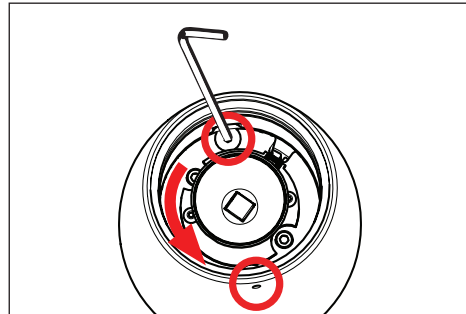

2. Rotate the two (2) 8-32 flat head cap screws using a 3/32" allen wrench clockwise until they bottom out into the heatsink, then rotate the heatsink so the screws line up with the grooves. Remove the two (2) 8-32 flat head cap screws from the heatsink completely.

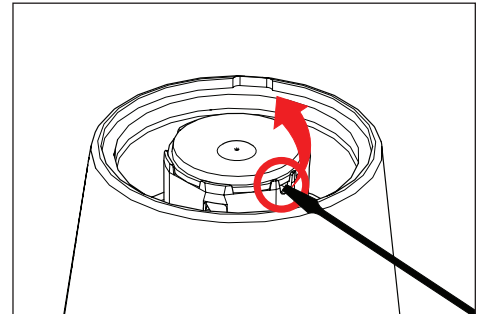

3. Use flat head screwdriver to gently remove optic from holder.

⚠ NOTE: To remove C Cap, use a suction cup, Caps will be provided with the replacement parts, not with new fixtures.

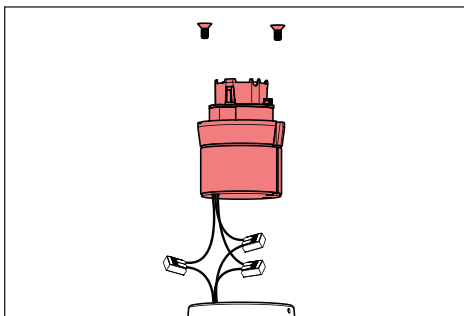

3. Disengage LED board and driver assembly.

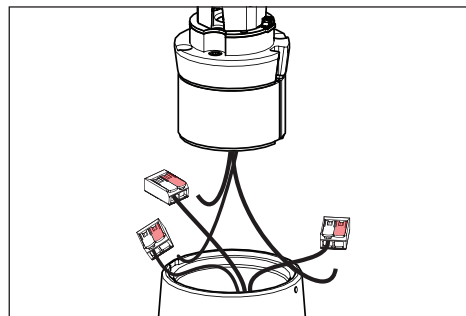

4. Disconnect driver assembly from fixture body.

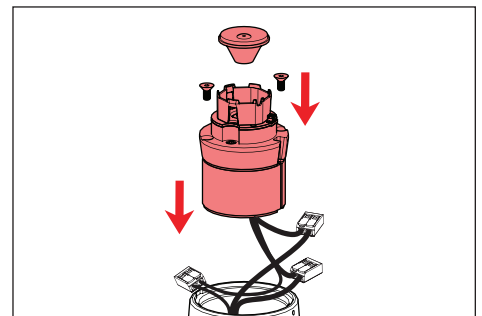

5. Connect new driver assembly to fixture leads. Gently snap new optic into holder. Place connections inside body cavity, reinsert new heatsink assy back into body. Reinstall two (2) 8-32 flat head cap screws completely onto the heatsink until screws catch under the groove on the body. Rotate the two (2) 8-32 flat head cap screws counterclockwise until they are snug against the top of the groove.

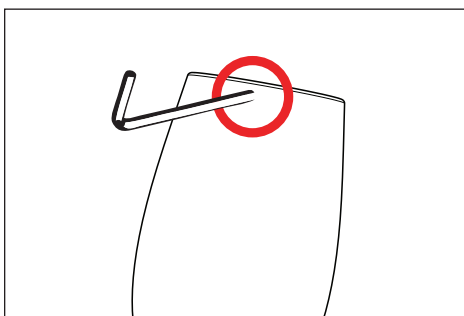

6. Place cap on fixture and tighten set screw. Tighten screw to 1/2 inch pounds.

⚠ Warning: Do not over tighten set screw. Doing so will compromise o-ring seal and will void warranty.

**IMPORTANT SAFETY INFORMATION LISTED ON REVERSE
READ, FOLLOW, AND SAVE ALL SAFETY AND INSTALLATION INSTRUCTIONS**

