

Standard Installation



Flammable



Warning



High Voltage



Hot Surface

TOOLS NEEDED:

- 5/32" & 5/64" Allen Wrench
- Waterproof Wire Connectors
- Phillips Screwdriver

INSTRUCTIONS PERTAINING TO A RISK OF FIRE, OR INJURY TO PERSONS IMPORTANT SAFETY INSTRUCTIONS

Lighted fixture is HOT!

WARNING - To reduce the risk of FIRE OR INJURY TO PERSONS:

Turn off/unplug and allow to cool before replacing lamp/LED. Fixture gets HOT quickly! Contact only switch/plug when turning on. Do not touch hot lens, guard, or enclosure. Keep fixture away from materials that may burn. Do not operate the luminaire fitting with a missing or damaged shield. Do not touch the source at any time. Use a soft cloth or gloves. Oil from skin may cause damage.

SAVE THESE INSTRUCTIONS

IMPORTANT SAFETY INFORMATION - READ, FOLLOW, AND SAVE ALL SAFETY AND INSTALLATION INSTRUCTIONS

- Product must be installed by a qualified person in a manner consistent with its intended use and in compliance with the National Electrical Code, Canadian Electrical Code, and all Local and Provincial Codes.
- Follow product label information and instructions.
- Qualified Personnel with appropriate personal protective equipment must perform all servicing of this product.
- Before wiring to power supply and during servicing, turn off and lock out power at fuse or circuit breaker before service.
- The use of accessory equipment not recommended by the manufacturer or installed contrary to instructions may cause an unsafe condition. The use of damaged components may cause an unsafe condition and void product warranty.
- Do not block light emanating from product in whole or part, as this may cause an unsafe condition.
- Never operate the fixture with missing or damaged lens. Lens must be cleaned on regular basis.
- Entire fixture may become extremely hot. Do not touch hot lens or fixture body.
- Replace LED assembly only with correct wattage and type of power supply appropriate for LED assembly.
- All gaskets, o-rings and sealing surfaces must be kept clean during installation and service; failure to do this may cause an unsafe condition and void product warranty.

IMPORTANT LISTINGS AND CERTIFICATIONS

- Suitable for wet locations

This set of instructions works for:

PTR-AR-TR

ArtiStar - Integrated LED System

For integral fixture configurations

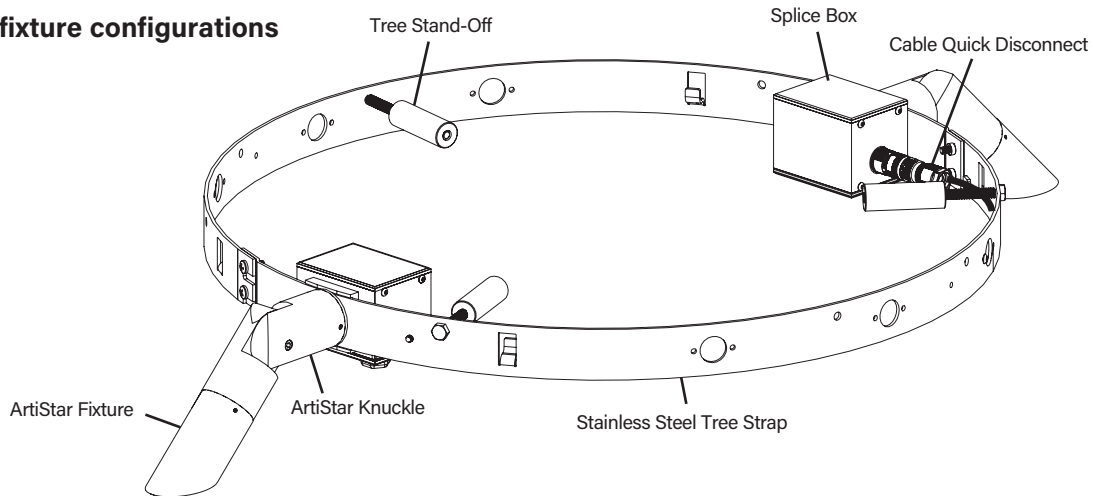

IMPORTANT SAFETY INFORMATION - READ, FOLLOW, AND SAVE THESE INSTALLATION INSTRUCTIONS

B-K LIGHTING

40429 Brickyard Drive • Madera, CA 93636 • USA
 559.438.5800 • FAX 559.438.5900
 www.bklighting.com • info@bklighting.com

RELEASE DATE
 03/17/2026

REFERENCE NUMBER
 INS-2811-00

THIS DOCUMENT CONTAINS PROPRIETARY INFORMATION OF B-K LIGHTING, INC. AND ITS RECEIPT OR POSSESSION DOES NOT CONVEY ANY RIGHTS TO REPRODUCE, DISCLOSE ITS CONTENTS, OR TO MANUFACTURE, USE OR SELL ANYTHING IT MAY DESCRIBE. REPRODUCTION, DISCLOSURE OR USE WITHOUT SPECIFIC WRITTEN AUTHORIZATION OF B-K LIGHTING, INC. IS STRICTLY FORBIDDEN.

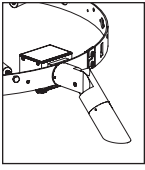

Standard Installation

ARTISTAR PALM TREE RING (7W) - INTEGRAL

Fixture Installation

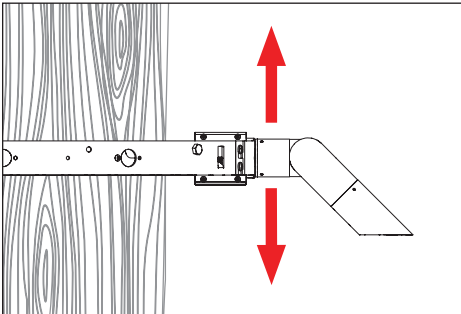

1. Place tree ring fixture around tree. Move fixture to desired height. Tighten the entire assembly to the tree with provided stand-offs.

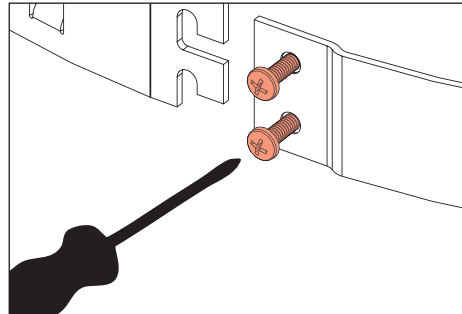

2. Secure by hooking end of strap over two (2) phillips screws. Secure by tightening two (2) phillips screws with phillips screwdriver.

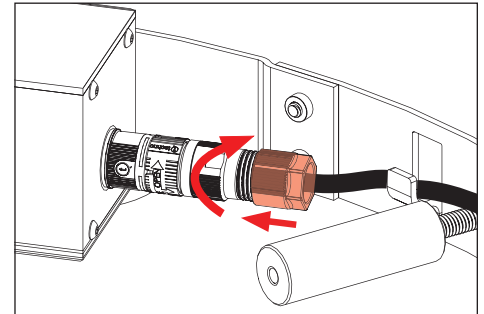

3. Connect secondary cable then twist to secure in place.

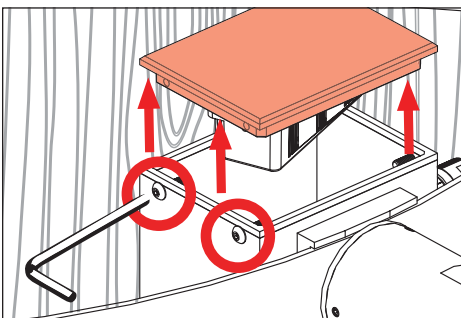

4. Remove top of transformer housing by removing four (4) #8-32 set screws using a 5/64" allen wrench.

⚠ Transformer housing will be marked for primary.

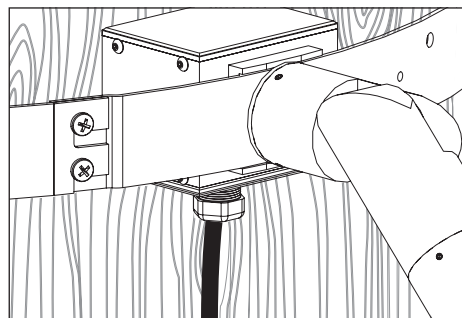

5. Bring line voltage cable from power line to main splice box location. Loosen cord grip on bottom of splice box, feed linevoltage cable from power line through, then tighten cord grip to secure.

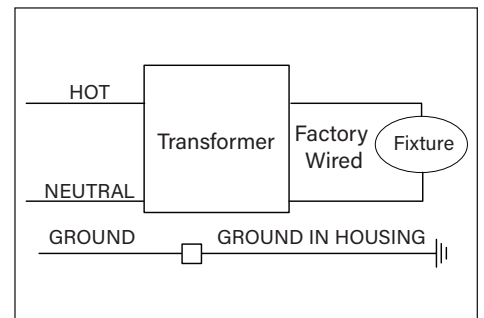

WIRING DIAGRAM

6. Make watertight connections from primary branch circuit to transformer with waterproof wire connectors (not included). Fixtures are pre-wired at factory on the secondary side. **See wiring diagram.**

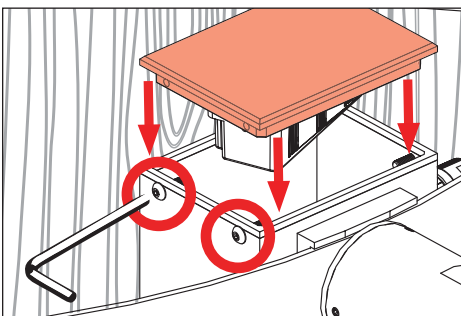

7. Replace top of transformer housing with four (4) #8-32 screws with a 5/64" allen wrench.

**IMPORTANT SAFETY INFORMATION LISTED ON REVERSE
READ, FOLLOW, AND SAVE ALL SAFETY AND INSTALLATION INSTRUCTIONS**



B-K LIGHTING

40429 Brickyard Drive • Madera, CA 93636 • USA
559.438.5800 • FAX 559.438.5900
www.bklighting.com • info@bklighting.com

RELEASE DATE
03/17/2026

REFERENCE NUMBER
INS-2811-00

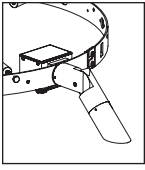

Standard Installation

ARTISTAR

PALM TREE RING (7W) - INTEGRAL

ArtiStar Knuckle

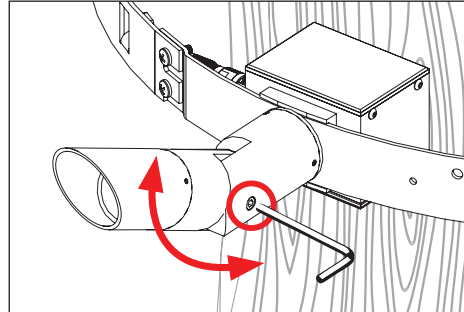
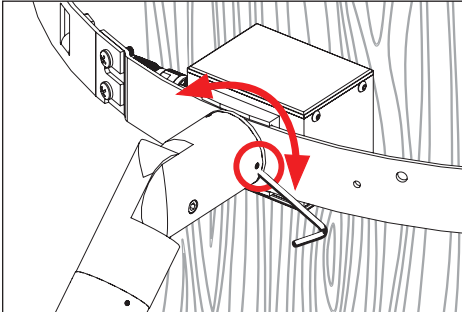

1. Use a 5/64" allen wrench to loosen three (3) #8-32 stainless steel set screws on fixture base. Rotate fixture at base and aim fixture to desired horizontal location, then tighten screw.
2. Use a 3/16" allen wrench to slightly loosen 1/4"-28 stainless steel black oxide socket head cap screw at the knuckle for vertical aiming purposes, then tighten screw.

⚠ Warning: Do not over tighten set screw. Doing so will compromise o-ring seal and will void warranty.

**IMPORTANT SAFETY INFORMATION LISTED ON REVERSE
READ, FOLLOW, AND SAVE ALL SAFETY AND INSTALLATION INSTRUCTIONS**



B-K LIGHTING

40429 Brickyard Drive • Madera, CA 93636 • USA
559.438.5800 • FAX 559.438.5900
www.bklighting.com • info@bklighting.com

RELEASE DATE
03/17/2026

REFERENCE NUMBER
INS-2811-00

ARTISTAR

LED BOARD & OPTICS REPLACEMENT

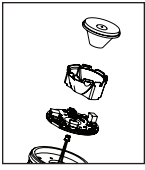

Standard Installation/Replacement



Flammable



Warning



Low Voltage



Hot Surface

TOOLS NEEDED:

- 5/64" & 9/64" Allen Wrench
- Small Flat Head Screwdriver
- Phillips Screwdriver

INSTRUCTIONS PERTAINING TO A RISK OF FIRE, OR INJURY TO PERSONS IMPORTANT SAFETY INSTRUCTIONS

Lighted fixture is HOT! WARNING - To reduce the risk of FIRE OR INJURY TO PERSONS:

Turn off/unplug and allow to cool before replacing lamp/LED. Fixture gets HOT quickly! Contact only switch/plug when turning on. Do not touch hot lens, guard, or enclosure. Keep fixture away from materials that may burn. Do not operate the luminaire fitting with a missing or damaged shield. Do not touch the source at any time. Use a soft cloth or gloves. Oil from skin may cause damage.

SAVE THESE INSTRUCTIONS

IMPORTANT SAFETY INFORMATION - READ, FOLLOW, AND SAVE ALL SAFETY AND INSTALLATION INSTRUCTIONS

- Product must be installed by a qualified person in a manner consistent with its intended use and in compliance with the National Electrical Code, Canadian Electrical Code, and all Local and Provincial Codes.
- Follow product label information and instructions.
- Qualified Personnel with appropriate personal protective equipment must perform all servicing of this product.
- Before wiring to power supply and during servicing, turn off and lock out power at fuse or circuit breaker before service.
- The use of accessory equipment not recommended by the manufacturer or installed contrary to instructions may cause an unsafe condition. The use of damaged components may cause an unsafe condition and void product warranty.
- Do not block light emanating from product in whole or part, as this may cause an unsafe condition.
- Never operate the fixture with missing or damaged lens. Lens must be cleaned on regular basis.
- Entire fixture may become extremely hot. Do not touch hot lens or fixture body.
- Replace LED assembly only with correct wattage and type of power supply appropriate for LED assembly.
- All gaskets, o-rings and sealing surfaces must be kept clean during installation and service; failure to do this may cause an unsafe condition and void product warranty.

IMPORTANT LISTINGS AND CERTIFICATIONS

Replacing LED Board/Driver and Optics

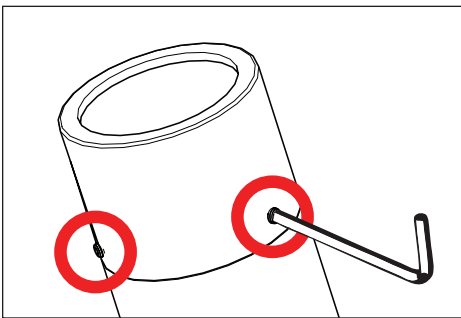

1. Remove cap by loosening three (3) #8-32 set screws using a 5/64" allen wrench. **Do not fully remove set screws**

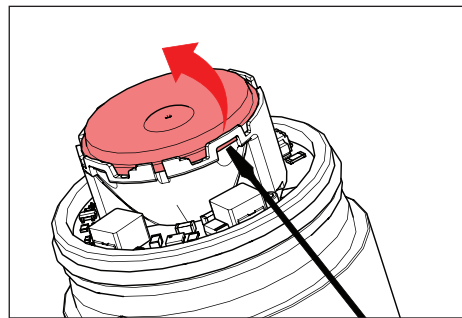

2. Use a flat head screwdriver to gently remove optic from holder.

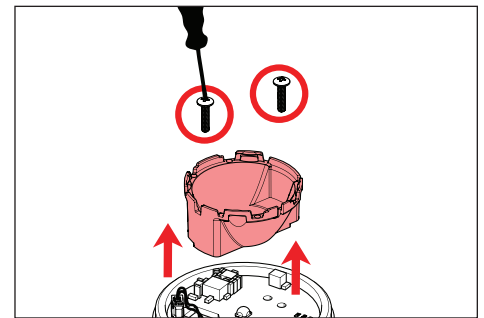

3. Remove optic holder by removing two (2) #2-56 screws using a phillips screwdriver.

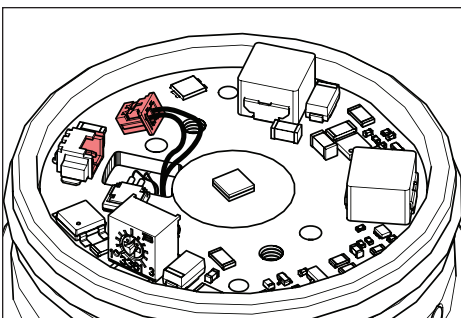

4. Disengage LED board. Replace with new board.

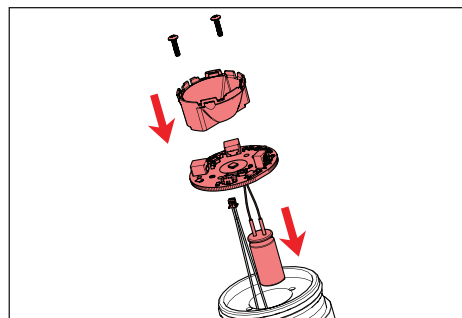

5. Reverse install LED board and optic holder. Carefully reconnect connector to LED and re-install. Re-install optic holder and gently snap optic into holder.

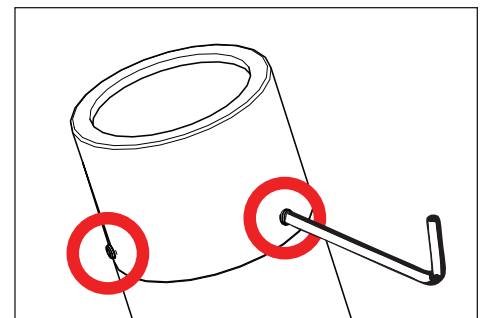

6. Re-install cap onto fixture. Secure by tightening three (3) #8-32 set screws using a 5/64" allen wrench. Top of set screws should sit flush with cap.

⚠ Warning: Do not over tighten set screws. Cap should be able to rotate without using force. Over tightening set screws will compromise o-ring seal and will void warranty.

IMPORTANT SAFETY INFORMATION - READ, FOLLOW, AND SAVE THESE INSTALLATION INSTRUCTIONS

B-K LIGHTING

40429 Brickyard Drive • Madera, CA 93636 • USA
559.438.5800 • FAX 559.438.5900
www.bklighting.com • info@bklighting.com

RELEASE DATE
03/17/2026

REFERENCE NUMBER
INS-2902-01

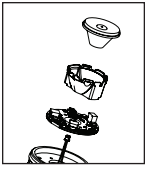

Standard Installation/Replacement

Change Lumen Output

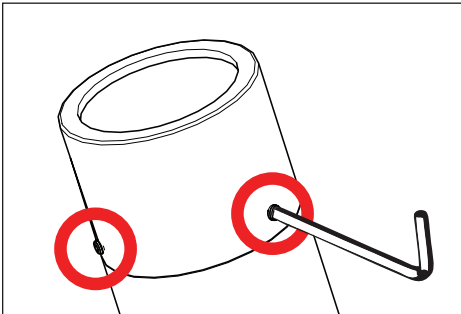

1. Use a 5/64" allen wrench to loosen #8-32 stainless set screw and remove cap.

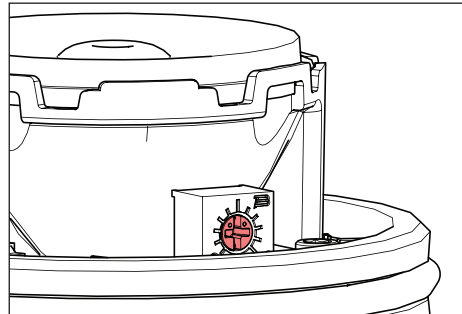

2. With flat head screwdriver rotate dial to desired lumen output.

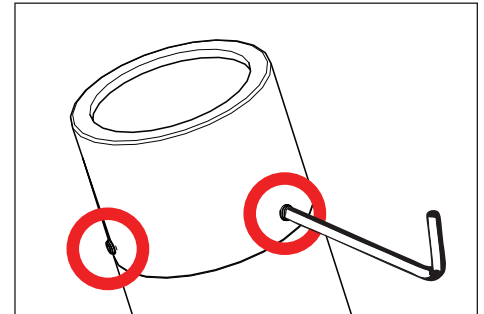

3. Place cap on fixture and tighten set screw. Tighten screw to 1/2 in-lbs. Top of screw should sit flush with fixture cap.

⚠ Warning: Do not over tighten set screw. Cap has to be able to move without using force. Doing so will compromise o-ring seal and will void warranty. Cap should be able to rotate without force.

**IMPORTANT SAFETY INFORMATION LISTED ON REVERSE
READ, FOLLOW, AND SAVE ALL SAFETY AND INSTALLATION INSTRUCTIONS**



B-K LIGHTING

40429 Brickyard Drive • Madera, CA 93636 • USA
559.438.5800 • FAX 559.438.5900
www.bklighting.com • info@bklighting.com

RELEASE DATE
03/17/2026

REFERENCE NUMBER
INS-2902-01