

Standard Installation



Flammable



Warning



High Voltage



Hot Surface

TOOLS NEEDED:



3/32", 5/32", & 5/64" Allen Wrench



Waterproof Wire Connectors

INSTRUCTIONS PERTAINING TO A RISK OF FIRE, OR INJURY TO PERSONS IMPORTANT SAFETY INSTRUCTIONS

Lighted fixture is HOT!

WARNING - To reduce the risk of FIRE OR INJURY TO PERSONS:

Turn off/unplug and allow to cool before replacing lamp/laser. Fixture gets HOT quickly! Contact only switch/plug when turning on. Do not touch hot lens, guard, or enclosure. Keep fixture away from materials that may burn. Do not operate the luminaire fitting with a missing or damaged shield. Do not touch the source at any time. Use a soft cloth or gloves. Oil from skin may cause damage.

SAVE THESE INSTRUCTIONS

IMPORTANT SAFETY INFORMATION - READ, FOLLOW, AND SAVE ALL SAFETY AND INSTALLATION INSTRUCTIONS

- Product must be installed by a qualified person in a manner consistent with its intended use and in compliance with the National Electrical Code, Canadian Electrical Code, and all Local and Provincial Codes.
- Follow product label information and instructions.
- Qualified Personnel with appropriate personal protective equipment must perform all servicing of this product.
- Before wiring to power supply and during servicing, turn off and lock out power at fuse or circuit breaker before service.
- The use of accessory equipment not recommended by the manufacturer or installed contrary to instructions may cause an unsafe condition. The use of damaged components may cause an unsafe condition and void product warranty.
- Do not block light emanating from product in whole or part, as this may cause an unsafe condition.
- Never operate the fixture with missing or damaged lens. Lens must be cleaned on regular basis.
- Entire fixture may become extremely hot. Do not touch hot lens or fixture body.
- Replace laser assembly only with correct wattage and type of power supply appropriate for laser assembly.
- All gaskets, o-rings and sealing surfaces must be kept clean during installation and service; failure to do this may cause an unsafe condition and void product warranty.

IMPORTANT LISTINGS AND CERTIFICATIONS

- Suitable for wet locations • Additionally suitable for mounting within 4 ft. of the ground

SQ-RI - Square Rio Lazr

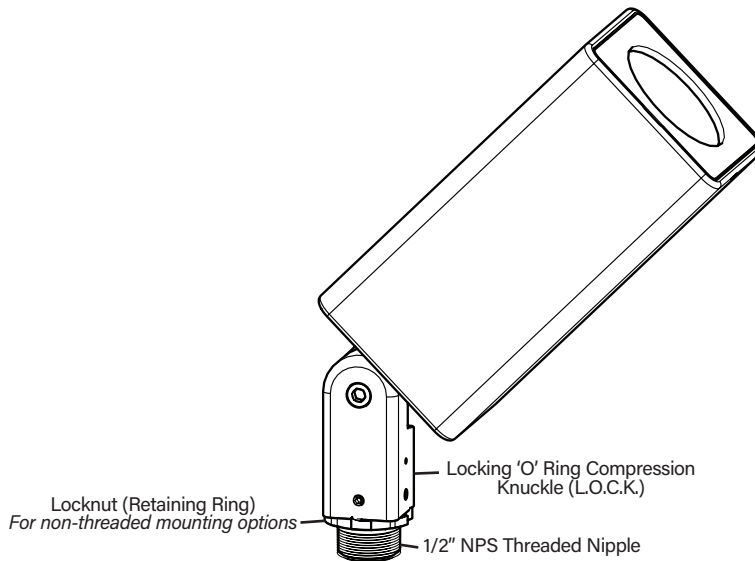

IMPORTANT SAFETY INFORMATION - READ, FOLLOW, AND SAVE THESE INSTALLATION INSTRUCTIONS

B-K LIGHTING

40429 Brickyard Drive • Madera, CA 93636 • USA
559.438.5800 • FAX 559.438.5900
www.bklighting.com • info@bklighting.com

RELEASE DATE
08/13/2025

REFERENCE NUMBER
INS-2881-00

THIS DOCUMENT CONTAINS PROPRIETARY INFORMATION OF B-K LIGHTING, INC. AND ITS RECEIPT OR POSSESSION DOES NOT CONVEY ANY RIGHTS TO REPRODUCE, DISCLOSE ITS CONTENTS, OR TO MANUFACTURE, USE OR SELL ANYTHING IT MAY DESCRIBE. REPRODUCTION, DISCLOSURE OR USE WITHOUT SPECIFIC WRITTEN AUTHORIZATION OF B-K LIGHTING, INC. IS STRICTLY FORBIDDEN.

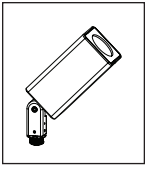

Standard Installation

Fixture Installation with Standard 360SL Knuckle

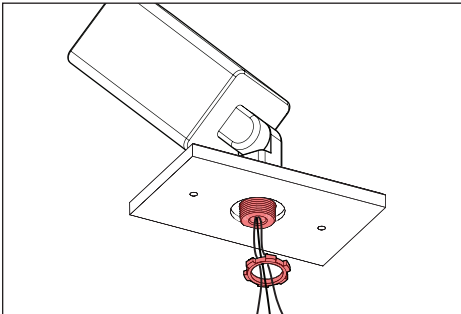

1. Mount knuckle onto suitable enclosure according to designed lighting plan.
2. Secure 1/2" NPS stem to mounting option. Secure with provided locknut if applicable.

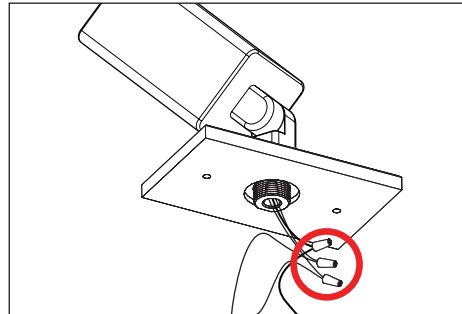

3. Make watertight connections from remote transformer to fixture leads using waterproof wire connectors (not included). See wiring diagram.

⚠ Failure to use waterproof wire connectors will cause fixture to fail and VOID PRODUCT WARRANTY.

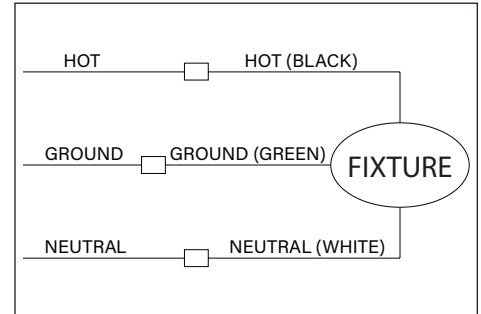

WIRING DIAGRAM

⚠ All line voltage connections must be made in compliance with the National Electrical Code. Failure to do so will void warranty.

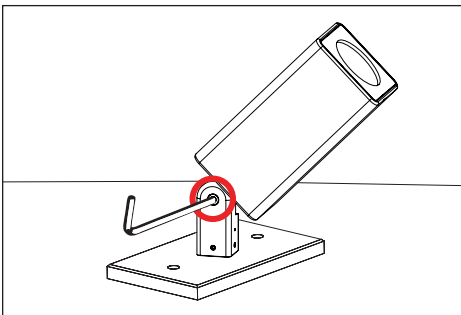

4. Use a 5/32" allen wrench to slightly loosen #10-32 stainless steel black oxide socket head cap screw at the knuckle for vertical aiming purposes. Tighten #10-32 stainless steel black oxide socket head cap screw to 15 in-lbs minimum to 30 in-lbs maximum to secure vertical aiming position.

⚠ Warning: Do not over tighten set screw. Doing so will compromise o-ring seal and will void warranty.

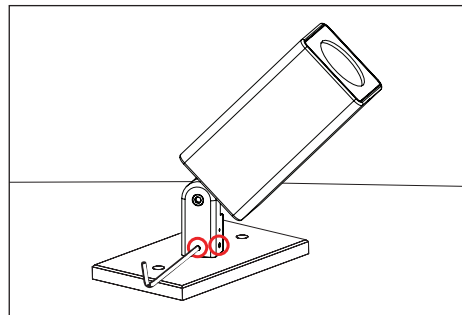

5. Use a 5/64" allen wrench to slightly loosen two (2) #8-32 stainless steel set screws on the stem for 360° aiming purpose.

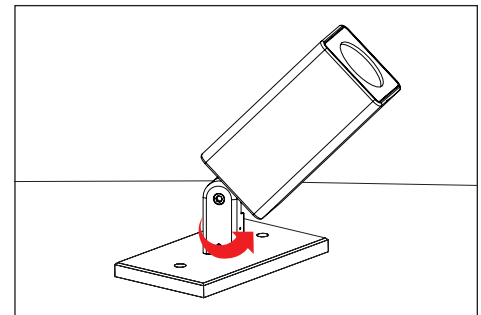

6. Rotate fixture at base and aim fixture to desired horizontal location.
7. Tighten two (2) #8-32 stainless steel set screws on stem to secure horizontal aiming position.

**IMPORTANT SAFETY INFORMATION LISTED ON REVERSE
READ, FOLLOW, AND SAVE ALL SAFETY AND INSTALLATION INSTRUCTIONS**



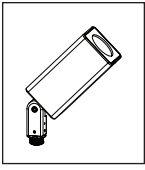

Standard Installation

Replacing Laser Board/Driver/Optics Assembly

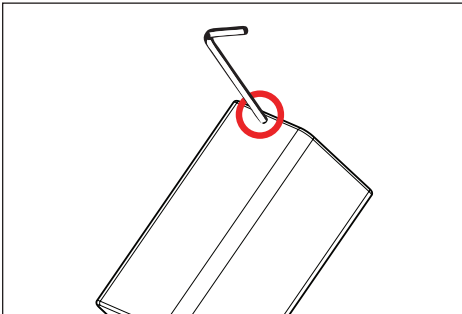

1. Use a 1/16" allen wrench to loosen #6-32 stainless set screw and remove cap.

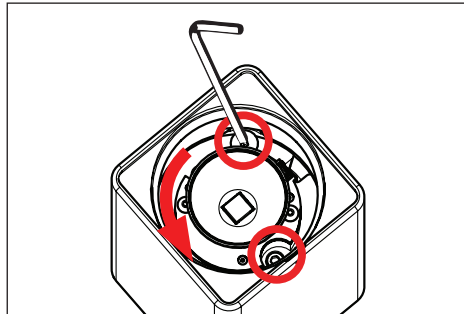

2. Rotate the two (2) 8-32 flat head cap screws using a 3/32" allen wrench clockwise until they bottom out into the heatsink. Then rotate the heatsink so they screws line up with the grooves. Remove the two (2) 8-32 flat head cap screws from the heatsink completely.

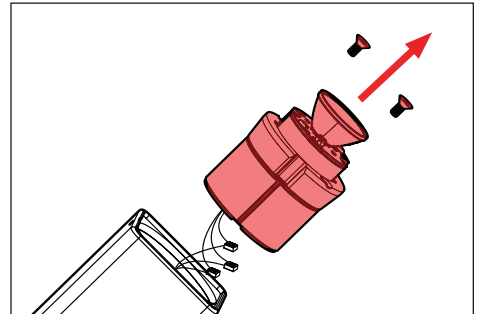

3. Disengage laser board and driver assembly.

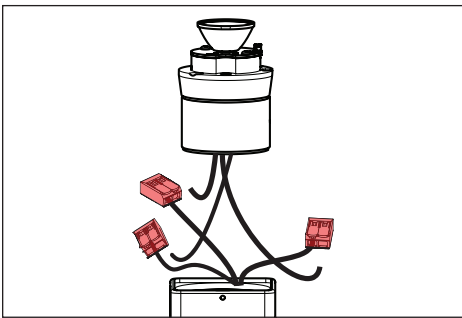

4. Disconnect driver assembly from fixture body.

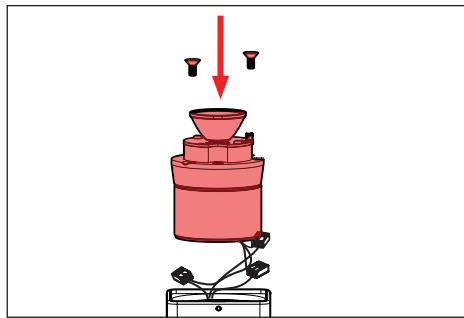

5. Connect new driver assembly to fixture leads. Place connections inside body cavity, reinsert new heatsink assembly back into body. Reinstall two (2) 8-32 flat head cap screws completely onto the heatsink until screws catch under the groove on the body. Rotate the two (2) 8-32 flat head cap screws counterclockwise until they are snug against the top of the groove.

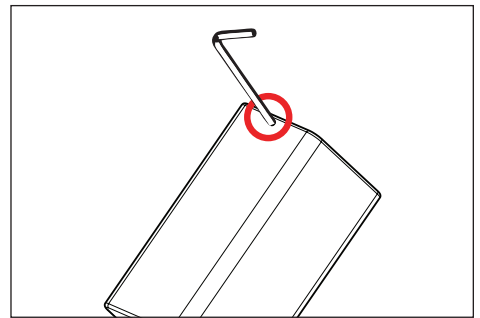

6. Place cap on fixture and tighten set screw. Tighten screw to 1/2 in-lbs. Top of screw should sit flush with fixture body.

Warning: Do not over tighten set screw. Doing so will compromise o-ring seal and will void warranty.

**IMPORTANT SAFETY INFORMATION LISTED ON REVERSE
READ, FOLLOW, AND SAVE ALL SAFETY AND INSTALLATION INSTRUCTIONS**

