

### Standard Installation

# ARTISTAR

## CATENARY INTEGRAL (7W) - LED



Flammable



Warning



High Voltage



Hot Surface

#### TOOLS NEEDED:



1/8", 9/64", & 5/64" Allen Wrench



Waterproof Wire Connectors (Included)



1/4" O.D. Aircraft Cable

### INSTRUCTIONS PERTAINING TO A RISK OF FIRE, OR INJURY TO PERSONS IMPORTANT SAFETY INSTRUCTIONS

#### Lighted fixture is HOT!

#### WARNING - To reduce the risk of FIRE OR INJURY TO PERSONS:

Turn off/unplug and allow to cool before replacing lamp/LED. Fixture gets HOT quickly! Contact only switch/plug when turning on. Do not touch hot lens, guard, or enclosure. Keep fixture away from materials that may burn. Do not operate the luminaire fitting with a missing or damaged shield. Do not touch the source at any time. Use a soft cloth or gloves. Oil from skin may cause damage.

**SAVE THESE INSTRUCTIONS**

### IMPORTANT SAFETY INFORMATION - READ, FOLLOW, AND SAVE ALL SAFETY AND INSTALLATION INSTRUCTIONS

- Product must be installed by a qualified person in a manner consistent with its intended use and in compliance with the National Electrical Code, Canadian Electrical Code, and all Local and Provincial Codes.
- Follow product label information and instructions.
- Qualified Personnel with appropriate personal protective equipment must perform all servicing of this product.
- Before wiring to power supply and during servicing, turn off and lock out power at fuse or circuit breaker before service.
- The use of accessory equipment not recommended by the manufacturer or installed contrary to instructions may cause an unsafe condition. The use of damaged components may cause an unsafe condition and void product warranty.
- Do not block light emanating from product in whole or part, as this may cause an unsafe condition.
- Never operate the fixture with missing or damaged lens. Lens must be cleaned on regular basis.
- Entire fixture may become extremely hot. Do not touch hot lens or fixture body.
- Replace LED assembly only with correct wattage and type of power supply appropriate for LED assembly.
- All gaskets, o-rings and sealing surfaces must be kept clean during installation and service; failure to do this may cause an unsafe condition and void product warranty.

### IMPORTANT LISTINGS AND CERTIFICATIONS

- Suitable for wet locations

### Acrylics Cap Option

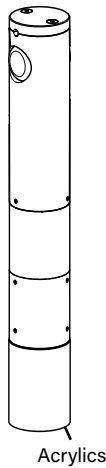

Acrylics

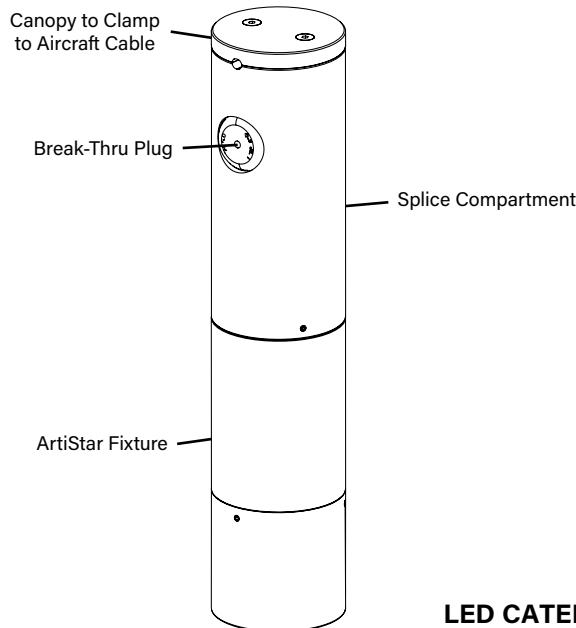

### LED CATENARY CABLE MOUNT ARTISTAR WITH INTEGRAL TRANSFORMER

AR-CA

### IMPORTANT SAFETY INFORMATION - READ, FOLLOW, AND SAVE THESE INSTALLATION INSTRUCTIONS

# B-K LIGHTING

40429 Brickyard Drive • Madera, CA 93636 • USA  
559.438.5800 • FAX 559.438.5900  
www.bklighting.com • info@bklighting.com

RELEASE DATE  
03/17/2026

REFERENCE NUMBER  
INS-2813-00

THIS DOCUMENT CONTAINS PROPRIETARY INFORMATION OF B-K LIGHTING, INC. AND ITS RECEIPT OR POSSESSION DOES NOT CONVEY ANY RIGHTS TO REPRODUCE, DISCLOSE ITS CONTENTS, OR TO MANUFACTURE, USE OR SELL ANYTHING IT MAY DESCRIBE. REPRODUCTION, DISCLOSURE OR USE WITHOUT SPECIFIC WRITTEN AUTHORIZATION OF B-K LIGHTING, INC. IS STRICTLY FORBIDDEN.

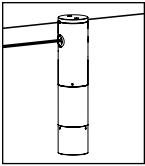

## Standard Installation

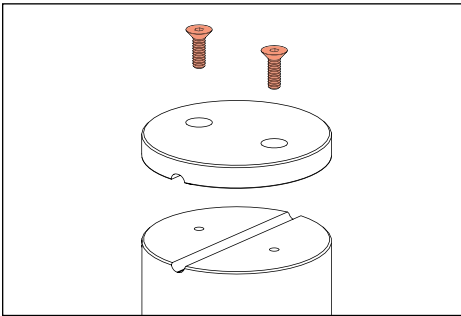

1. Using a 1/8" allen wrench back out two (2) #10-24 cap screws from clamp to separate.

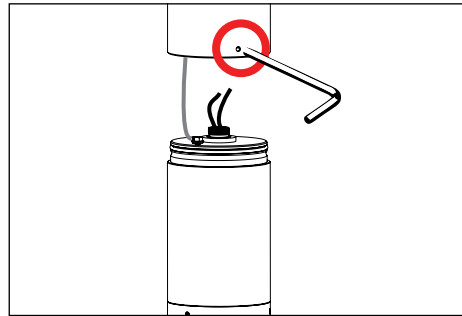

2. Use a 5/64" allen wrench to separate splice compartment and fixture body.

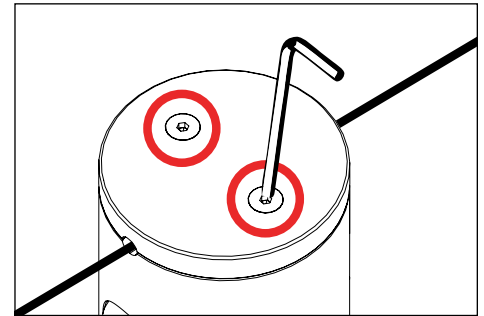

3. Install clamp to splice compartment to 1/4" O.D. aircraft cable with two (2) #10-24 cap screws using a 1/8" allen wrench.

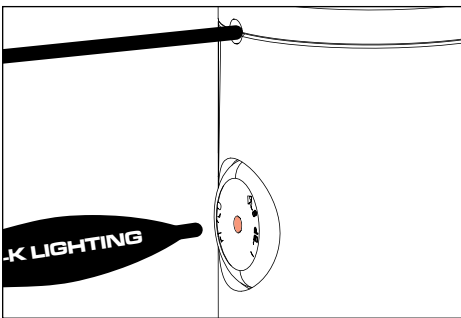

4. Pierce center of break-thru plug with ball point pen

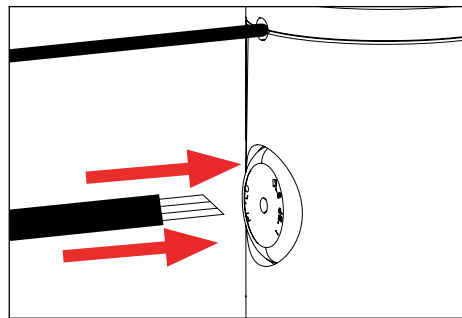

5. Bring branch circuit wiring with ROUND jacketed line voltage cable to splice compartment. (.130" min to .450" max. dia., Cable By Others)

Cut cable at 45 degree angle. Push through break-thru plug to insert cable.

**NOTE:** ROUND jacketed line voltage cable must be used. (.130" min to .450" max).

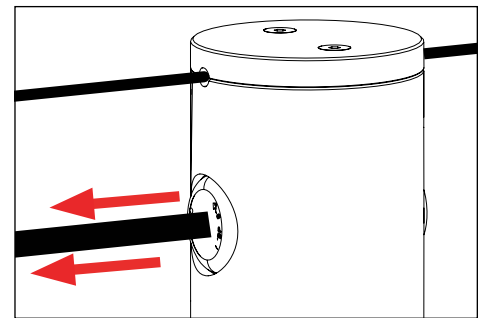

6. Pull back cable gently to form a tight seal.

**NOTE:** For supplemental wire clamp instructions, please see next page.

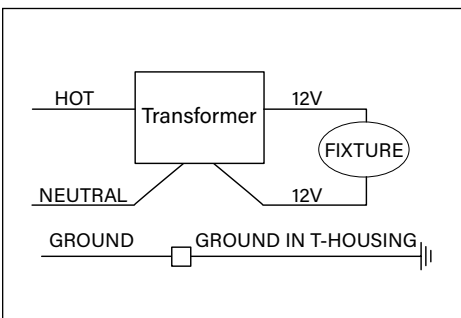

### WIRING DIAGRAM

7. Make watertight connections from primary branch circuit wiring to transformer using supplied waterproof wire connectors. Connect incoming ground to transformer ground wire and ground wire provided in fixture body located inside splice compartment. Secondary side is factory-wired. See wiring diagram.

**NOTE:** Contractor is responsible for executing water tight splice.

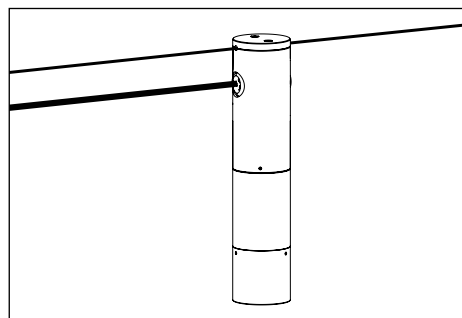

8. Place connections inside splice compartment. Attach fixture body to splice compartment. Tighten #8-32 stainless steel set screws with 5/64" Allen wrench.

**NOTE:** Do not over-tighten set screws.

**IMPORTANT SAFETY INFORMATION LISTED ON REVERSE  
READ, FOLLOW, AND SAVE ALL SAFETY AND INSTALLATION INSTRUCTIONS**



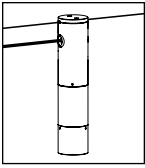

Standard Installation

**Supplemental Wire Clamp Option (WC)**

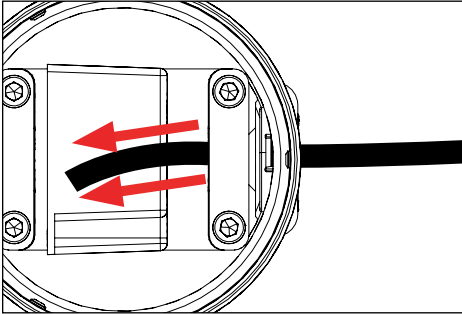

1. Thread incoming 3 wire ROUND jacketed line voltage cable through grommet, then through strain relief clamp.

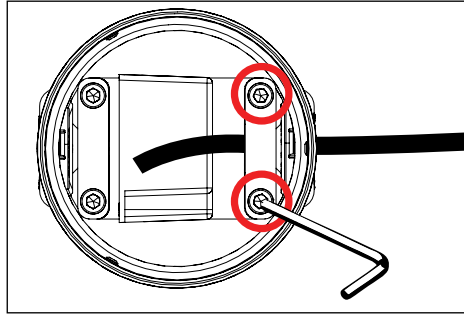

2. Secure strain relief clamp by tightening two (2) #8-32 screws with a 9/64" allen wrench.

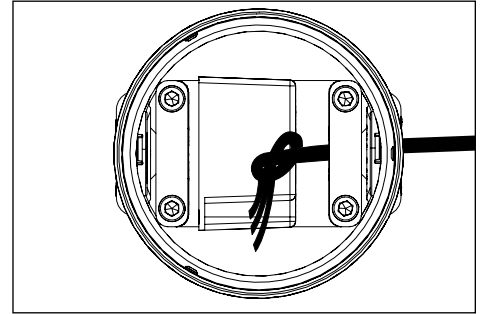

3. Tie underwriter's knot in cable for additional strain relief between connections and clamp.

**⚠ Do not overtighten.**

**IMPORTANT SAFETY INFORMATION LISTED ON REVERSE  
READ, FOLLOW, AND SAVE ALL SAFETY AND INSTALLATION INSTRUCTIONS**



**B-K LIGHTING**

40429 Brickyard Drive • Madera, CA 93636 • USA  
559.438.5800 • FAX 559.438.5900  
www.bklighting.com • info@bklighting.com

RELEASE DATE  
03/17/2026

REFERENCE NUMBER  
INS-2813-00

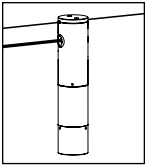

### Standard Installation

# ARTISTAR

## CATENARY INTEGRAL (7W) - LED

### Replacing LED Board/Driver and Optics

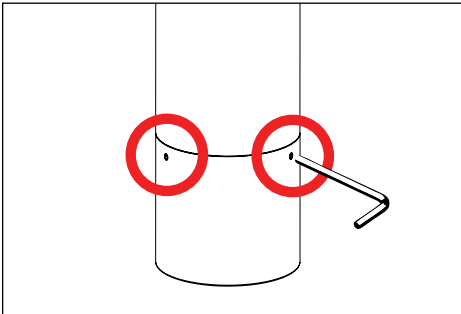

1. Use a 5/64" allen wrench to loosen #8-32 stainless set screw and remove cap.

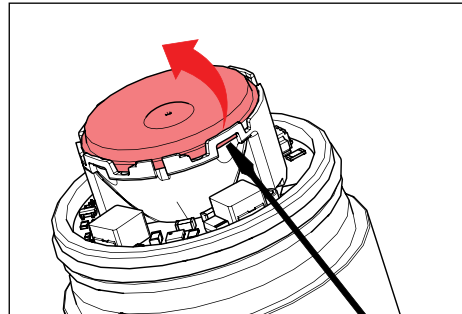

2. Use a flat head screwdriver to gently remove optic from holder.

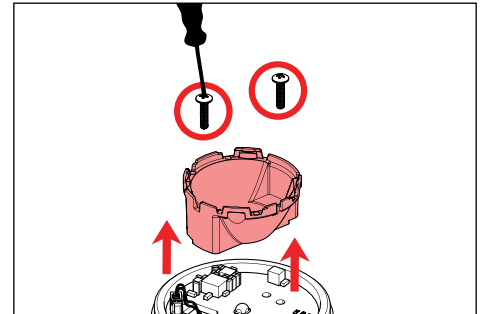

3. Remove optic holder by removing two (2) #2-56 screws using a phillips screwdriver.

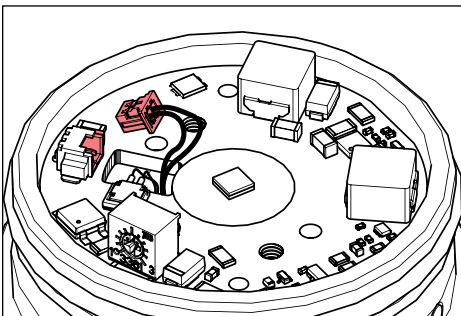

4. Disengage LED board. Replace with new board.

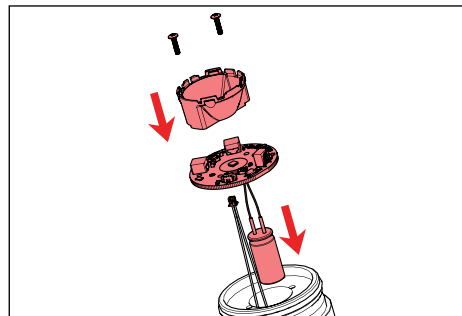

5. Reverse install LED board and optic holder. Carefully reconnect connector to LED and re-install. Re-install optic holder and gently snap optic into holder.

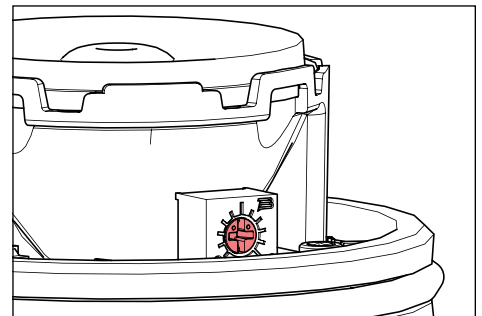

6. With flat head screw driver rotate dial to desired lumen output.

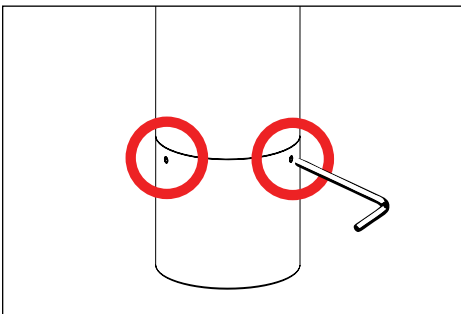

7. Place cap on fixture and tighten set screws. Tighten screw to 1/2 in-lbs. Top of screws should sit flush with fixture cap.

**Warning:** Do not over tighten set screws. Doing so will compromise o-ring seal and will void warranty.

**IMPORTANT SAFETY INFORMATION LISTED ON REVERSE  
READ, FOLLOW, AND SAVE ALL SAFETY AND INSTALLATION INSTRUCTIONS**



# B-K LIGHTING

40429 Brickyard Drive • Madera, CA 93636 • USA  
559.438.5800 • FAX 559.438.5900  
www.bklighting.com • info@bklighting.com

RELEASE DATE  
03/17/2026

REFERENCE NUMBER  
INS-2813-00